Line Card Timing ICs with up to 5 Channels, 10 Inputs, 20 Outputs Product Brief

Features

Highlights

- Up to five independent clock channels
- Any-to-any frequency conversion per channel
- Inputs: up to 10, differential or single-ended
- Outputs: up to 10 differential, up to 20 CMOS
- Output jitter $100 f_{s_{RMS}}$ typical for 156.25 MHz
12 kHz to 20 MHz
- Core power consumption <0.9W
- MiToDSync™ 1-wire time-of-day interface in/out
- MiToDBasic™ 3-wire time-of-day interface out

Input Clocks

- Accepts up to 10 differential or CMOS inputs
- Any input frequency from 1 kHz to 1250 MHz
- Per-input activity and frequency monitoring
- Automatic or manual reference switching
- Revertive or nonrevertive switching
- Any input can be a 0.5 Hz to 8 kHz Sync input for Ref-Sync frequency/phase/time locking
- Any input can be a clock with embedded Sync
- Input phase measurement, 1 ps resolution
- Per-input phase adjustment, 1 ps resolution

Up to 8 DPLLs

- Hitless reference switching
- High-resolution holdover averaging
- Per-DPLL phase adjustment, 1 ps resolution
- Programmable bandwidth, tracking range, phase-slope limiting, frequency-change limiting and other advanced features
- Locking to gapped-clock input signals

Output Clocks

- Any frequency 0.5 Hz to 750 MHz
- Each OUTP/N pair can be LVDS, LVPECL, 2xC-MOS, Low- V_{CM} , or programmable differential

- In 2xCMOS mode, the P and N pins can be different frequencies (e.g. 125 MHz and 25 MHz)
- VDD per output pair, CMOS voltages 1.8V to 3.3V
- Per-synth phase adjustment, 1 ps resolution
- Per-output duty cycle adjustment
- Precise output alignment circuitry and per-output phase adjustment
- Per-output enable/disable and glitchless start/stop (stop high or low)

Local Oscillator

- Operates from a single oscillator 9.72 MHz to 400 MHz
- Very-low-jitter applications can connect a TCXO or OCXO as the stability reference and a low-jitter XO as the jitter reference

General Features

- Automatic self-configuration at power-up from internal Flash memory, 7 configurations
- Input-to-output alignment <100 ps
- Fast Ref-Sync locking for frequency and 1PPS phase alignment with lower-cost oscillator
- Numerically controlled oscillator behavior in each DPLL and each synthesizer
- Easy-to-configure design requires no external VCXO or loop filter components
- 5 GPIO pins with many possible behaviors, each REF can be GPI, each OUT can be GPO
- SPI or I²C processor Interface
- 1.8V and 3.3V core VDD voltages
- Easy-to-use evaluation/programming software

Applications

- Line card timing ICs for SyncE, SyncE+1588, routers, switches, OTN, and other carrier-grade systems
- Wireless base stations (3G, W-CDMA, 4G/LTE, LTE-A, 5G)
- Remote Radio Unit (RRU), Remote Access Networks (RAN), small cells, wireless backhaul, wireless repeaters

ZL30641 - ZL30645

1.0 BLOCK DIAGRAM

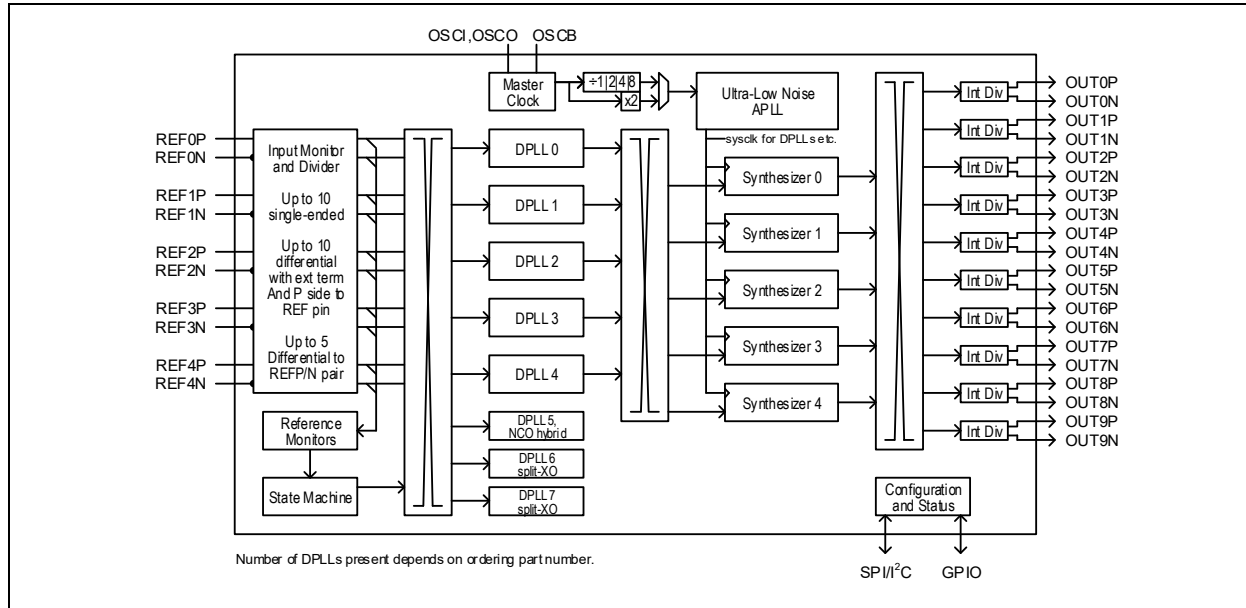

FIGURE 1-1: Functional Block Diagram.

2.0 APPLICATION EXAMPLE

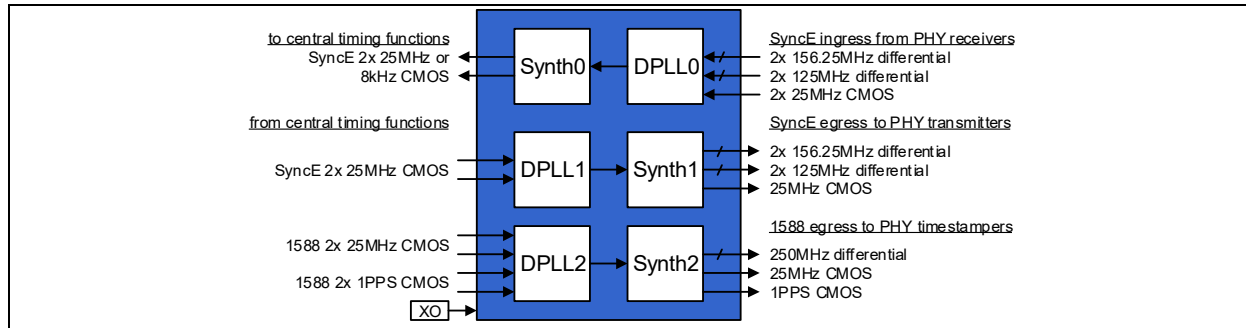

FIGURE 2-1: Synchronous Ethernet and IEEE 1588 Central Timing Application.

3.0 DETAILED FEATURES

3.1 General

- Up to five independent clock channels
- Operates from a single crystal resonator or clock oscillator
 - ≥ 48 MHz for lowest jitter
 - 9.72 MHz to 400 MHz total frequency range
- Configurable via SPI or I²C interface
- Internal nonvolatile memory
 - Factory-configurable power-on configuration
 - Multiple time writeable/re-writeable
- Default settings can be overridden using SPI/I²C

3.2 Input Block Features

- Ten input reference pins; each can accept a CMOS signal or the POS side of a differential pair; or two can be paired to accept both sides of a differential pair (see [Figure 6-3](#))
- Any input can be a SYNC signal (0.5 Hz to 8 kHz) for Ref-Sync frequency/phase/time locking
- Any input can be a clock with embedded Sync signal (0.5 Hz to 1 kHz, duty cycle distortion for Sync)
- Any input can be a MiToDSync signal carrying one to three channels of frequency/phase/ToD information
- Input clocks can be any frequency from 1 kHz up to 1250 MHz (300 MHz max for CMOS inputs)
- Supported telecom frequencies include PDH, SDH, Synchronous Ethernet, OTN, wireless
- Inputs constantly monitored by programmable frequency and single-cycle monitors
- Single-cycle monitor can quickly disqualify a reference when measured period is incorrect
- Frequency measurement and monitoring (coarse, fine, and frequency-step monitors)
- Optional input clock invalidation on GPIO or GPI assertion to react to LOS signals from PHYs
- Input phase measurement, 1 ps resolution
- Per-input phase adjustment, 1 ps resolution
- Each REF pin can be a GPI (general-purpose input)

3.3 DPLL Features

- Up to eight DPLLs: up to five for clock I/O channels, one for NCO-hybrid mode (SyncE assist), and two for locking to OCXOs for split-XO configuration
- Very high-resolution DPLL architecture
- State machine automatically transitions among freerun, tracking, and holdover states
- Revertive or nonrevertive reference selection algorithm
- Programmable bandwidth from 5 Hz to 470 Hz
- Fast frequency/phase/time lock capability for clock+1PPS input references
- Programmable phase-slope limiting (PSL)
- Programmable frequency rate-of-change limiting (FCL)
- Programmable tracking range (i.e. hold-in range)
- Truly hitless reference switching
- Per-DPLL phase adjustment, 1 ps resolution
- High-resolution frequency and phase measurement (4e-15 and 1 ps)
- Fast detection of input clock failure and transition to holdover mode
- Supports holdover compensation for oscillator aging and temperature changes by learning oscillator characteristics during locked operation
- Time-of-Day registers: 48-bit seconds, 32-bit nanoseconds, writeable on input PPS edge

3.4 Synthesizer Features

- Five next-generation low-jitter, low-power, any-frequency synthesizers
- A total of five output frequency families
- Any-to-any frequency conversion with 0 ppm error
- Easy-to-configure, completely encapsulated design requires no external VCXO or loop filter components
- Jitter suitable for OC-192, STM-64, and 1G, 10G, 40G, 100G, and 400G Ethernet jitter requirements

ZL30641 - ZL30645

3.5 Output Clock Features

- Up to 20 single-ended outputs, up to 10 differential outputs, from any synthesizer
- Each output can be one differential output or two CMOS outputs
- Output clocks can be any frequency from 0.5 Hz to 750 MHz (250 MHz max for CMOS)
- Output jitter $100 f_{s_{RMS}}$ typical for 156.25 MHz and many other frequencies (12 kHz to 20 MHz)
- In CMOS mode, the OUTxN frequency can be an integer divisor of the OUTxP frequency (Example 1: OUT3P 125 MHz, OUT3N 25 MHz. Example 2: OUT2P 25 MHz, OUT2N 1 Hz)
- Outputs directly interface (DC-coupled) with LVDS, LVPECL, HCSL, and CMOS components
- Supported telecom frequencies include PDH, SDH, Synchronous Ethernet, OTN
- Can produce clock frequencies for microprocessors, ASICs, FPGAs, and other components
- Can produce PCIe Gen 1 to 5 clocks
- Each output pair can have clock plus embedded Sync signal (0.5 Hz to clock div 4)
- Each output pair can be MiToDSync signals carrying one to three channels of frequency/phase/ToD information
- Sophisticated output-to-output phase alignment
- Per-synthesizer phase adjustment, 1 ps resolution
- Per-output phase adjustment to accommodate trace delays or compensate for system routing paths
- Per-output duty cycle/pulse width configuration
- Per-output enable/disable
- Per-output glitchless start/stop (stop high or low)
- Each OUT pin can be a GPO (general-purpose output)
- Each OUT pin can be a MiToDBasic data signal which can be combined with a MHz clock output and a 4 kHz sync output to form a 3-wire MiToDBasic interface carrying one channel of frequency/phase/ToD information

3.6 Local Oscillator

- Operates from a single oscillator (jitter reference for the device). Acceptable frequencies: 9.72 MHz to 400 MHz. Best jitter: ≥ 48 MHz.
- Very-low-jitter applications can connect a TCXO or OCXO (any frequency, any output jitter) as the stability reference and a low-cost low-jitter XO as the jitter reference
- This ability to have separate jitter and stability references greatly reduces the cost of the TCXO or OCXO (no jitter requirement, no high-frequency-requirement) and allows reuse of already-qualified TCXO and OCXO components
- Supports redundant TCXOs or OCXOs connected to two REF pins

3.7 General Features

- Automatic self-configuration at power-up from internal Flash memory
- Input-to-output alignment < 200 ps with external feedback
- Fast Ref-Sync locking for frequency and 1PPS phase alignment with lower-cost oscillator
- Generates output SYNC signals: 1PPS (IEEE 1588), 2 kHz or 8 kHz (SONET/SDH), or other frequency
- JESD204B clocking: clock and SYSREF signal generation with skew adjustment
- Numerically controlled oscillator (NCO) behavior allows system software to steer DPLL frequency or synthesizer frequency with resolution better than 0.005 ppt
- Spread-spectrum modulation available in each synthesizer (PCIe compliant)
- Five general-purpose I/O pins each with many possible status and control options
- SPI or I²C serial microprocessor interface

3.8 Evaluation Software

- Simple, intuitive Windows-based graphical user interface
- Supports all device features and register fields
- Makes lab evaluation of the device quick and easy
- Generates configuration scripts
- Works with or without an evaluation board

4.0 PIN DIAGRAM

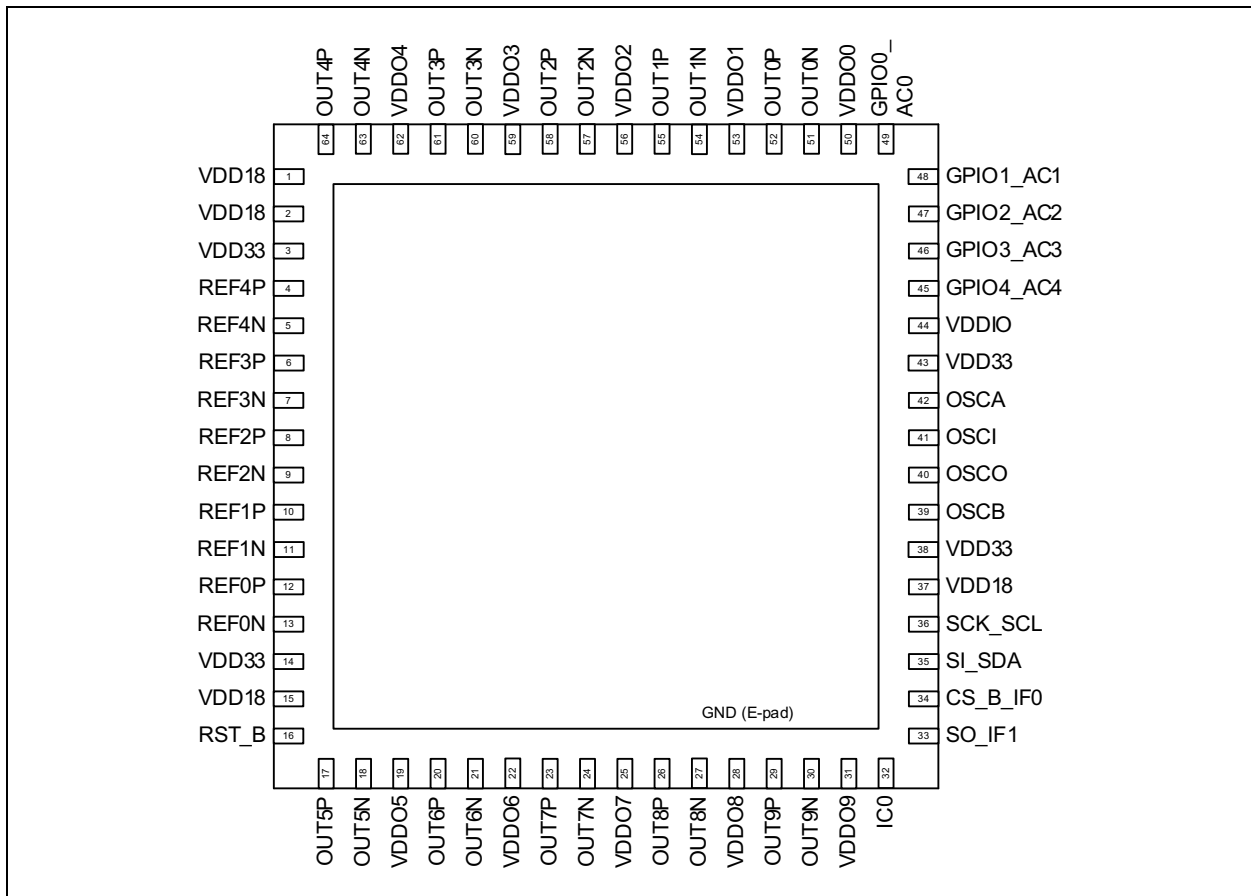

FIGURE 1: 64-Lead 9 mm x 9 mm VQFN (0.5 mm pitch) for ZL30641, ZL30642, ZL30643, ZL30644, ZL30645.

ZL30641 - ZL30645

NOTES:

Note the following details of the code protection feature on Microchip products:

- Microchip products meet the specifications contained in their particular Microchip Data Sheet.
- Microchip believes that its family of products is secure when used in the intended manner, within operating specifications, and under normal conditions.
- Microchip values and aggressively protects its intellectual property rights. Attempts to breach the code protection features of Microchip product is strictly prohibited and may violate the Digital Millennium Copyright Act.
- Neither Microchip nor any other semiconductor manufacturer can guarantee the security of its code. Code protection does not mean that we are guaranteeing the product is “unbreakable”. Code protection is constantly evolving. Microchip is committed to continuously improving the code protection features of our products.

This publication and the information herein may be used only with Microchip products, including to design, test, and integrate Microchip products with your application. Use of this information in any other manner violates these terms. Information regarding device applications is provided only for your convenience and may be superseded by updates. It is your responsibility to ensure that your application meets with your specifications. Contact your local Microchip sales office for additional support or, obtain additional support at <https://www.microchip.com/en-us/support/design-help/client-support-services>.

THIS INFORMATION IS PROVIDED BY MICROCHIP "AS IS". MICROCHIP MAKES NO REPRESENTATIONS OR WARRANTIES OF ANY KIND WHETHER EXPRESS OR IMPLIED, WRITTEN OR ORAL, STATUTORY OR OTHERWISE, RELATED TO THE INFORMATION INCLUDING BUT NOT LIMITED TO ANY IMPLIED WARRANTIES OF NON-INFRINGEMENT, MERCHANTABILITY, AND FITNESS FOR A PARTICULAR PURPOSE, OR WARRANTIES RELATED TO ITS CONDITION, QUALITY, OR PERFORMANCE.

IN NO EVENT WILL MICROCHIP BE LIABLE FOR ANY INDIRECT, SPECIAL, PUNITIVE, INCIDENTAL, OR CONSEQUENTIAL LOSS, DAMAGE, COST, OR EXPENSE OF ANY KIND WHATSOEVER RELATED TO THE INFORMATION OR ITS USE, HOWEVER CAUSED, EVEN IF MICROCHIP HAS BEEN ADVISED OF THE POSSIBILITY OR THE DAMAGES ARE FORESEEABLE. TO THE FULLEST EXTENT ALLOWED BY LAW, MICROCHIP'S TOTAL LIABILITY ON ALL CLAIMS IN ANY WAY RELATED TO THE INFORMATION OR ITS USE WILL NOT EXCEED THE AMOUNT OF FEES, IF ANY, THAT YOU HAVE PAID DIRECTLY TO MICROCHIP FOR THE INFORMATION.

Use of Microchip devices in life support and/or safety applications is entirely at the buyer's risk, and the buyer agrees to defend, indemnify and hold harmless Microchip from any and all damages, claims, suits, or expenses resulting from such use. No licenses are conveyed, implicitly or otherwise, under any Microchip intellectual property rights unless otherwise stated.

Trademarks

The Microchip name and logo, the Microchip logo, Adaptec, AnyRate, AVR, AVR logo, AVR Freaks, BesTime, BitCloud, CryptoMemory, CryptoRF, dsPIC, flexPWR, HELDO, IGLoo, JukeBlox, KeeLoq, Klear, LANCheck, LinkMD, maXStylus, maXTouch, MediaLB, megaAVR, Microsemi, Microsemi logo, MOST, MOST logo, MPLAB, OptoLyzer, PIC, picoPower, PICSTART, PIC32 logo, PolarFire, Prochip Designer, QTouch, SAM-BA, SenGenuity, SpyNIC, SST, SST Logo, SuperFlash, Symmetricom, SyncServer, Tachyon, TimeSource, tinyAVR, UNI/O, Vectron, and XMEGA are registered trademarks of Microchip Technology Incorporated in the U.S.A. and other countries.

AgileSwitch, APT, ClockWorks, The Embedded Control Solutions Company, EtherSynch, Flashtec, Hyper Speed Control, HyperLight Load, IntelliMOS, Libero, motorBench, mTouch, Powermite 3, Precision Edge, ProASIC, ProASIC Plus, ProASIC Plus logo, Quiet-Wire, SmartFusion, SyncWorld, Temux, TimeCesium, TimeHub, TimePictra, TimeProvider, TrueTime, WinPath, and ZL are registered trademarks of Microchip Technology Incorporated in the U.S.A.

Adjacent Key Suppression, AKS, Analog-for-the-Digital Age, Any Capacitor, AnyIn, AnyOut, Augmented Switching, BlueSky, BodyCom, CodeGuard, CryptoAuthentication, CryptoAutomotive, CryptoCompanion, CryptoController, dsPICDEM, dsPICDEM.net, Dynamic Average Matching, DAM, ECAN, Espresso T1S, EtherGREEN, GridTime, IdealBridge, In-Circuit Serial Programming, ICSP, INICnet, Intelligent Paralleling, Inter-Chip Connectivity, JitterBlocker, Knob-on-Display, maxCrypto, maxView, memBrain, Mindi, MiWi, MPASM, MPF, MPLAB Certified logo, MPLIB, MPLINK, MultiTRAK, NetDetach, NVM Express, NVMe, Omniscient Code Generation, PICDEM, PICDEM.net, PICkit, PICtail, PowerSmart, PureSilicon, QMatrix, REAL ICE, Ripple Blocker, RTAX, RTG4, SAM-ICE, Serial Quad I/O, simpleMAP, SimpliPHY, SmartBuffer, SmartHLS, SMART-I.S., storClad, SQI, SuperSwitcher, SuperSwitcher II, Switchtec, SynchroPHY, Total Endurance, TSHARC, USBCheck, VariSense, VectorBlox, VeriPHY, ViewSpan, WiperLock, XpressConnect, and ZENA are trademarks of Microchip Technology Incorporated in the U.S.A. and other countries.

SQTP is a service mark of Microchip Technology Incorporated in the U.S.A.

The Adaptec logo, Frequency on Demand, Silicon Storage Technology, Symmcom, and Trusted Time are registered trademarks of Microchip Technology Inc. in other countries.

GestIC is a registered trademark of Microchip Technology Germany II GmbH & Co. KG, a subsidiary of Microchip Technology Inc., in other countries.

All other trademarks mentioned herein are property of their respective companies.

© 2021, Microchip Technology Incorporated and its subsidiaries. All Rights Reserved.

ISBN: 978-1-5224-9398-3

For information regarding Microchip's Quality Management Systems, please visit www.microchip.com/quality.



MICROCHIP

Worldwide Sales and Service

AMERICAS

Corporate Office
2355 West Chandler Blvd.
Chandler, AZ 85224-6199
Tel: 480-792-7200
Fax: 480-792-7277
Technical Support:
[http://www.microchip.com/
support](http://www.microchip.com/support)
Web Address:
www.microchip.com

Atlanta

Duluth, GA
Tel: 678-957-9614
Fax: 678-957-1455

Austin, TX

Tel: 512-257-3370

Boston

Westborough, MA
Tel: 774-760-0087
Fax: 774-760-0088

Chicago

Itasca, IL
Tel: 630-285-0071
Fax: 630-285-0075

Dallas

Addison, TX
Tel: 972-818-7423
Fax: 972-818-2924

Detroit

Novi, MI
Tel: 248-848-4000

Houston, TX

Tel: 281-894-5983

Indianapolis

Noblesville, IN
Tel: 317-773-8323
Fax: 317-773-5453
Tel: 317-536-2380

Los Angeles

Mission Viejo, CA
Tel: 949-462-9523
Fax: 949-462-9608
Tel: 951-273-7800

Raleigh, NC

Tel: 919-844-7510

New York, NY

Tel: 631-435-6000

San Jose, CA

Tel: 408-735-9110
Tel: 408-436-4270

Canada - Toronto

Tel: 905-695-1980
Fax: 905-695-2078

ASIA/PACIFIC

Australia - Sydney
Tel: 61-2-9868-6733

China - Beijing
Tel: 86-10-8569-7000

China - Chengdu
Tel: 86-28-8665-5511

China - Chongqing
Tel: 86-23-8980-9588

China - Dongguan
Tel: 86-769-8702-9880

China - Guangzhou
Tel: 86-20-8755-8029

China - Hangzhou
Tel: 86-571-8792-8115

China - Hong Kong SAR
Tel: 852-2943-5100

China - Nanjing
Tel: 86-25-8473-2460

China - Qingdao
Tel: 86-532-8502-7355

China - Shanghai
Tel: 86-21-3326-8000

China - Shenyang
Tel: 86-24-2334-2829

China - Shenzhen
Tel: 86-755-8864-2200

China - Suzhou
Tel: 86-186-6233-1526

China - Wuhan
Tel: 86-27-5980-5300

China - Xian
Tel: 86-29-8833-7252

China - Xiamen
Tel: 86-592-2388138

China - Zhuhai
Tel: 86-756-3210040

ASIA/PACIFIC

India - Bangalore
Tel: 91-80-3090-4444

India - New Delhi
Tel: 91-11-4160-8631

India - Pune
Tel: 91-20-4121-0141

Japan - Osaka
Tel: 81-6-6152-7160

Japan - Tokyo
Tel: 81-3-6880-3770

Korea - Daegu
Tel: 82-53-744-4301

Korea - Seoul
Tel: 82-2-554-7200

Malaysia - Kuala Lumpur
Tel: 60-3-7651-7906

Malaysia - Penang
Tel: 60-4-227-8870

Philippines - Manila
Tel: 63-2-634-9065

Singapore
Tel: 65-6334-8870

Taiwan - Hsin Chu
Tel: 886-3-577-8366

Taiwan - Kaohsiung
Tel: 886-7-213-7830

Taiwan - Taipei
Tel: 886-2-2508-8600

Thailand - Bangkok
Tel: 66-2-694-1351

Vietnam - Ho Chi Minh
Tel: 84-28-5448-2100

EUROPE

Austria - Wels
Tel: 43-7242-2244-39
Fax: 43-7242-2244-393

Denmark - Copenhagen
Tel: 45-4485-5910
Fax: 45-4485-2829

Finland - Espoo
Tel: 358-9-4520-820

France - Paris
Tel: 33-1-69-53-63-20
Fax: 33-1-69-30-90-79

Germany - Garching
Tel: 49-8931-9700

Germany - Haan
Tel: 49-2129-3766400

Germany - Heilbronn
Tel: 49-7131-72400

Germany - Karlsruhe
Tel: 49-721-625370

Germany - Munich
Tel: 49-89-627-144-0
Fax: 49-89-627-144-44

Germany - Rosenheim
Tel: 49-8031-354-560

Israel - Ra'anana
Tel: 972-9-744-7705

Italy - Milan
Tel: 39-0331-742611
Fax: 39-0331-466781

Italy - Padova
Tel: 39-049-7625286

Netherlands - Drunen
Tel: 31-416-690399
Fax: 31-416-690340

Norway - Trondheim
Tel: 47-7288-4388

Poland - Warsaw
Tel: 48-22-3325737

Romania - Bucharest
Tel: 40-21-407-87-50

Spain - Madrid
Tel: 34-91-708-08-90
Fax: 34-91-708-08-91

Sweden - Gothenberg
Tel: 46-31-704-60-40

Sweden - Stockholm
Tel: 46-8-5090-4654

UK - Wokingham
Tel: 44-118-921-5800
Fax: 44-118-921-5820

Looking for pricing, stock, or lifecycle information?

Click below to explore more details on WIN SOURCE:

- ⊖ [View ZL30642LDG1](#) on WIN SOURCE
- ⊖ [Microchip Technology](#) Information

Optimize Your Supply Chain with WIN SOURCE Solutions

- ✓ Global Sourcing Solution
- ✓ Obsolete Management
- ✓ Cost Control Management
- ✓ Shortage Management
- ✓ Alternative Solution
- ✓ Excess Inventory Management