



# THE DATASHEET OF TMUX121NKGR



# TMUX121 Low-Capacitance, 2-Channel, 2:1 Switch with Power-Off Isolation and 1.8-V Logic

## 1 Features

- [Compatible with high-speed I<sup>3</sup>C signals](#)
- High performance switch characteristics:
  - Bandwidth (–3 dB): 3.0 GHz
  - R<sub>ON</sub> (typical): 3 Ω
  - C<sub>ON</sub> (typical): 1.7 pF
  - T<sub>PD</sub> (typical): 60 ps
  - T<sub>SWEK</sub> (typical): 2 ps
- Low current consumption: 12 μA (typical)
- Special features:
  - I<sub>POFF</sub> protection prevents current leakage in Powered-Down state
  - 1.8 V and 3.3 V compatible control inputs (SEL,  $\overline{\text{EN}}$ )
- 3.3 V supply voltage
- Industrial temperature range: –40 to 125°C
- Compact 10-pin 1.4 mm × 1.8 mm, UQFN package

## 2 Applications

- I<sup>3</sup>C (SenseWire)
- I<sup>3</sup>C and I<sup>2</sup>C peripheral switching
- [Servers](#)
- [Handset: smart phone](#)
- [Notebook PC](#)
- [Tablet: multimedia](#)
- [Electronic point-of-sale](#)
- [Field instrumentation](#)
- [Portable monitor](#)

## 3 Description

The TMUX121 is a high performance bidirectional 2-channel, 2:1 (SPDT) switch that supports both differential and single ended signals. The TMUX121 is an analog passive switch which features power-off protection forcing all I/O pins to be in high-impedance mode when power is not present on the V<sub>DD</sub> pin. The select and enable pins of the TMUX121 compatible with 1.8 V and 3.3 V control voltage, allowing them to be directly interfaced with the General purpose I/O (GPIO) from low voltage processors. This, along with the low on-resistance and low on capacitance of the device, make the TMUX121 an excellent choice for supporting switching a wide range of analog signals and digital communication protocol standards, including high-speed standards such as I<sup>3</sup>C.

The TMUX121 comes in a small 10-pin UQFN package with only 1.8 mm × 1.4 mm in size, which makes it useful when PCB area is limited.

### Package Information

PART NUMBER	PACKAGE <sup>(1)</sup>	PACKAGE SIZE <sup>(2)</sup>
TMUX121	NKG (UQFN, 10)	1.8 mm × 1.4 mm

- (1) For all available packages, see the orderable addendum at the end of the data sheet.
- (2) The package size (length × width) is a nominal value and includes pins, where applicable.

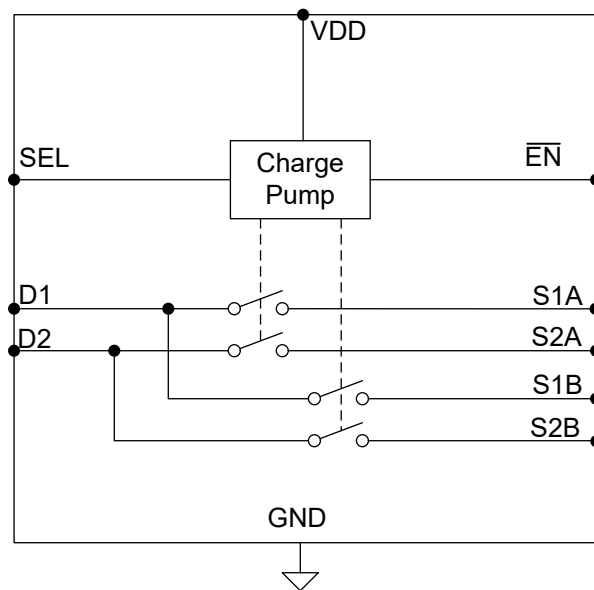

Application Use Case



## Table of Contents

<b>1 Features</b> .....	1	7.3 Feature Description.....	7
<b>2 Applications</b> .....	1	7.4 Device Functional Modes.....	7
<b>3 Description</b> .....	1	<b>8 Application and Implementation</b> .....	8
<b>4 Revision History</b> .....	2	8.1 Application Information.....	8
<b>5 Pin Configuration and Functions</b> .....	3	8.2 Typical Applications.....	8
<b>6 Specifications</b> .....	4	8.3 Power Supply Recommendations.....	9
6.1 Absolute Maximum Ratings.....	4	8.4 Layout.....	9
6.2 ESD Ratings.....	4	<b>9 Device and Documentation Support</b> .....	11
6.3 Recommended Operating Conditions.....	4	9.1 Related Documentation.....	11
6.4 Thermal Information.....	4	9.2 Receiving Notification of Documentation Updates....	11
6.5 Electrical Characteristics.....	5	9.3 Support Resources.....	11
6.6 Switching Characteristics.....	5	9.4 Trademarks.....	11
6.7 Typical Characteristics .....	6	9.5 Electrostatic Discharge Caution.....	11
<b>7 Detailed Description</b> .....	7	9.6 Glossary.....	11
7.1 Overview.....	7	<b>10 Mechanical, Packaging, and Orderable Information</b> .....	11
7.2 Functional Block Diagram.....	7		

## 4 Revision History

DATE	REVISION	NOTES
August 2023	*	Initial Release

## 5 Pin Configuration and Functions

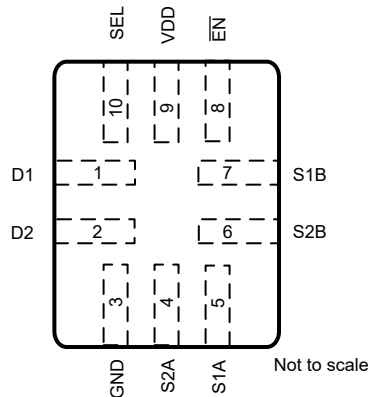

**Figure 5-1. TMUX121 NKG Package, 10-Pin UQFN (Top View)**

**Table 5-1. Pin Functions**

PIN		TYPE <sup>(1)</sup>	DESCRIPTION
NAME	NO.		
D1	1	I/O	Drain pin 1. Can be an input or output.
D2	2	I/O	Drain pin 2. Can be an input or output.
S1A	5	I/O	Source pin 1A. Can be an input or output.
S2A	4	I/O	Source pin 2A. Can be an input or output.
S1B	7	I/O	Source pin 1B. Can be an input or output.
S2B	6	I/O	Source pin 2B. Can be an input or output.
SEL	10	IN	Switch logic control input. Controls the switch connection as provided in <a href="#">Table 7-1</a> .
$\overline{\text{EN}}$	8	IN	Active low enable input. Controls the switch connection as provided in <a href="#">Table 7-1</a> .
VDD	9	P	3.3 V power supply
GND	3	G	Ground

(1) IN = input, I/O = input or output, P = power, G = ground

## 6 Specifications

### 6.1 Absolute Maximum Ratings

over operating free-air temperature range (unless otherwise noted)<sup>(1)</sup>

		MIN	MAX	UNIT
V <sub>DD</sub>	Supply voltage	-0.5	4.0	V
V <sub>EN</sub> or V <sub>SEL</sub>	Logic control input pin current (SEL, EN)	-0.5	4.0	V
V <sub>D</sub> or V <sub>S</sub>	Source or drain voltage (Sx, Dx)	-0.5	5.5	V
T <sub>stg</sub>	Storage temperature	-65	150	°C
T <sub>J</sub>	Junction temperature	-40	125	°C

- (1) Operation outside the *Absolute Maximum Rating* may cause permanent device damage. *Absolute Maximum Rating* do not imply functional operation of the device at these or any other conditions beyond those listed under *Recommended Operating Condition*. If used outside the *Recommended Operating Condition* but within the *Absolute Maximum Rating*, the device may not be fully functional, and this may affect device reliability, functionality, performance, and shorten the device lifetime.

### 6.2 ESD Ratings

		VALUE	UNIT
V <sub>ESD</sub>	Electrostatic discharge	Human-body model (HBM), per ANSI/ESDA/JEDEC JS-001 <sup>(1)</sup>	V
		Charged device model (CDM), per ANSI/ESDA/JEDEC JS-002 <sup>(2)</sup>	

- (1) JEDEC document JEP155 states that 500-V HBM allows safe manufacturing with a standard ESD control process.  
 (2) JEDEC document JEP157 states that 250-V CDM allows safe manufacturing with a standard ESD control process.

### 6.3 Recommended Operating Conditions

over operating free-air temperature range (unless otherwise noted)

		MIN	TYP	MAX	UNIT
V <sub>DD</sub>	Power Supply voltage	3.0	3.3	3.6	V
V <sub>DDRAMP</sub>	Power Supply voltage ramp time	0.1		100	ms
V <sub>D</sub> or V <sub>S</sub>	Source or drain voltage (Sx, Dx)	0		3.6	V
V <sub>EN</sub> or V <sub>SEL</sub>	Logic control input pin current (SEL, EN)	0		3.6	V
I <sub>S</sub> or I <sub>D</sub> (cont)	Source or drain continuous current (Sx, Dx)			90	mA
T <sub>A</sub>	Operating free-air/ambient temperature	-40		125	°C

### 6.4 Thermal Information

THERMAL METRIC <sup>(1)</sup>		TMUX121	UNIT
		NKG (UQFN)	
		10 PINS	
R <sub>θJA</sub>	Junction-to-ambient thermal resistance - High K	225.9	°C/W
R <sub>θJC(top)</sub>	Junction-to-case (top) thermal resistance	93.5	°C/W
R <sub>θJB</sub>	Junction-to-board thermal resistance	147.5	°C/W
ψ <sub>JT</sub>	Junction-to-top characterization parameter	3.4	°C/W
ψ <sub>JB</sub>	Junction-to-board characterization parameter	147.1	°C/W

- (1) For more information about traditional and new thermal metrics, see the [Semiconductor and IC Package Thermal Metrics](#) application report.

## 6.5 Electrical Characteristics

Over operating free-air temperature and supply voltage range (unless otherwise noted)  
Typical at  $V_{DD} = 3.3\text{ V}$   $T_A = 25^\circ\text{C}$  (unless otherwise noted)

PARAMETER		TEST CONDITIONS	MIN	TYP	MAX	UNIT
$I_{DDQ}$	$V_{DD}$ quiescent supply current	$EN = V_{DD}$		1.3	4	$\mu\text{A}$
$I_{DD}$	$V_{DD}$ supply current	$EN = 0\text{ V}$		11	30	$\mu\text{A}$
$R_{ON}$	On-resistance	$V_S = 0\text{ V}$ , $I_S = -8\text{ mA}$		3	5.4	$\Omega$
		$V_S = 2.4\text{ V}$ , $I_S = -8\text{ mA}$		3.9	8	$\Omega$
$\Delta R_{ON}$	On-resistance mismatch between channels	$V_S = 0\text{ V}$ , $I_S = -8\text{ mA}$			0.5	$\Omega$
		$V_S = 2.4\text{ V}$ , $I_S = -8\text{ mA}$			0.5	$\Omega$
$R_{ON\text{ FLAT}}$	On-resistance flatness	$V_S = 0\text{ V}$ and $V_S = 2.4\text{ V}$ ; $I_S = -8\text{ mA}$		1		$\Omega$
$I_{S(ON)}$ $I_{D(ON)}$	Channel on leakage current ( $S_x$ , $D_x$ )	Switch state is on $V_D = V_S = 3.6\text{ V}$			2	$\mu\text{A}$
		Switch state is on $V_D = V_S = 0\text{ V}$			0.2	$\mu\text{A}$
$I_{S(OFF)}$	Source off leakage current ( $S_x$ )	Switch state is off $V_S = 3.6\text{ V}$			2	$\mu\text{A}$
$I_{D(OFF)}$	Drain off leakage current ( $D_x$ )	Switch state is off $V_D = 3.6\text{ V}$			2	$\mu\text{A}$
$I_{(POFF)}$	Powered-off leakage current ( $S_x$ , $D_x$ )	$V_{CC} = 0\text{ V}$ , $V_D$ or $V_S = 3.6\text{ V}$			10	$\mu\text{A}$
$V_{IH}$	Logic voltage high (EN, SEL)		1.4		3.6	V
$V_{IL}$	Logic voltage low (EN, SEL)		0		0.4	V
$I_{IL}$	Input leakage current (EN, SEL)				0.2	$\mu\text{A}$
$I_{IH}$	Input leakage current (EN, SEL)				1	$\mu\text{A}$
$I_{IH}$	Failsafe Input leakage current (EN, SEL)	$V_{CC} = 0\text{ V}$ , $V_{EN}$ or $V_{SEL} = 3.6\text{ V}$			10	$\mu\text{A}$

## 6.6 Switching Characteristics

over operating free-air temperature and supply voltage range (unless otherwise noted)

PARAMETER			MIN	TYP	MAX	UNIT
$t_{TRAN}$	Transition time from control input (SEL)	$R_L = 50\ \Omega$ , $C_L = 10\text{ pF}$			1	$\mu\text{s}$
$t_{ON}$	Turn-on time from control input (EN)	$R_L = 50\ \Omega$ , $C_L = 10\text{ pF}$			16	$\mu\text{s}$
$t_{OFF}$	Turn-off time from control input (EN)	$R_L = 50\ \Omega$ , $C_L = 10\text{ pF}$			0.5	$\mu\text{s}$
$t_{PD}$	Switch propagation delay ( $S_x$ to $D_x$ or $D_x$ to $S_x$ )			60	80	ps
$t_{SKEW\_INTRA}$	Intra-pair propagation delay skew for same channel			2	10	ps
$t_{SKEW\_INTER}$	Inter-pair propagation delay skew between channels			2	10	ps
BW	-3-dB bandwidth			3		GHz
$I_L$	Differential insertion loss	$f = 10\text{ MHz}$		-0.3		dB
$O_{ISO}$	Differential OFF isolation (D to SA/SB)	$f = 10\text{ MHz}$		-56		dB
$X_{TALK}$	Differential cross-talk (SA to SB or SB to SA)	$f = 10\text{ MHz}$		-64		dB
$C_{S(ON)}$ $C_{D(ON)}$	On capacitance	$f = 10\text{ MHz}$		1.7		pF

## 6.7 Typical Characteristics

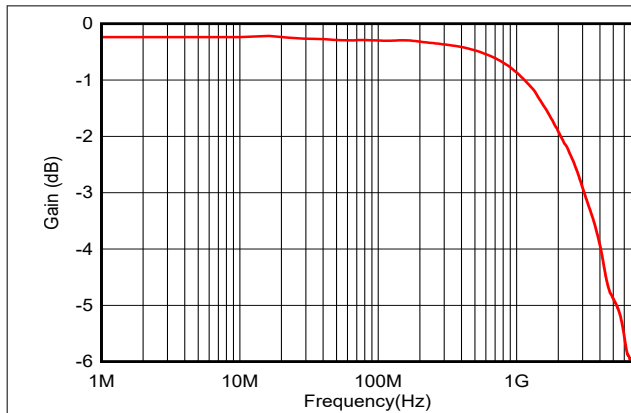

Figure 6-1. Typical Differential Bandwidth vs Frequency

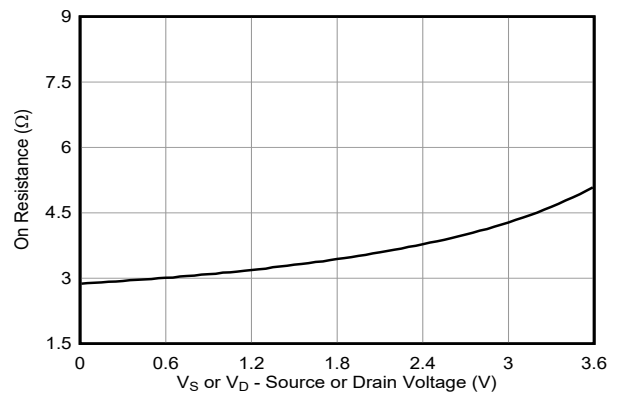

Figure 6-2.  $R_{ON}$  vs Common Mode Voltage VCM

## 7 Detailed Description

### 7.1 Overview

The TMUX121 is an analog passive 2 channel 2:1 (SPDT) that can work for any low-speed, high-speed, differential or single ended signals. Excellent low capacitance characteristics of the device allow signal switching with minimal attenuation and very little added jitter. The signals must be within the allowable voltage range of 0 to 3.6 V.

### 7.2 Functional Block Diagram

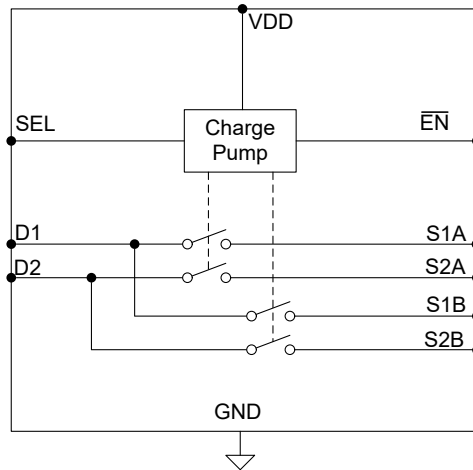

### 7.3 Feature Description

#### 7.3.1 Enable and Low Power Mode

The TMUX121 can be placed in a power saving mode by pulling  $\overline{\text{EN}}$  high. This reduces the supply power consumption from 12  $\mu\text{A}$  to 1.5  $\mu\text{A}$ , which is extremely beneficial for systems where saving power is critical.

### 7.4 Device Functional Modes

**Table 7-1. Mux Configuration Control Logic for TMUX121** <sup>(1)</sup>

SEL	$\overline{\text{EN}}$	Mux Configuration
L	L	D to SA
H	L	D to SB
X	H	All channels are disabled and Hi-Z

- (1) The TMUX121 can tolerate polarity inversions for differential signals. Keep the polarity consistent for all differential pairs.

## 8 Application and Implementation

### Note

Information in the following applications sections is not part of the TI component specification, and TI does not warrant its accuracy or completeness. TI's customers are responsible for determining suitability of components for their purposes, as well as validating and testing their design implementation to confirm system functionality.

### 8.1 Application Information

The TMUX121 is an analog high-speed mux or demux that can be used for routing differential as well as single ended signals through it. The device can be used for many interfaces including I<sup>2</sup>C and I<sup>3</sup>C.

An available GPIO pin of a controller or hard tie to voltage level H or L can easily control the mux or demux selection pin (SEL) of the device as an application requires. The switch path is passive and therefore bidirectional.

### 8.2 Typical Applications

#### 8.2.1 Signal Expansion (I<sup>3</sup>C and I<sup>2</sup>C)

There are many applications in which microprocessors or controllers have a limited number of I/Os. The TMUX121 solution can effectively expand the limited I/Os by switching between multiple buses to interface them to a single microprocessor or controller. A common application where the TMUX121 is as a I<sup>3</sup>C 1:2 multiplexer. In this application, the TMUX121 is used to route communicating between different peripherals from a single controller or driver within a server, as shown in Figure 8-1. The high bandwidth of the TMUX121 will preserve signal integrity at even the fastest communication protocols that may be used in server applications, such as I<sup>3</sup>C. Also, because I<sup>3</sup>C is backwards compatible, any of the peripherals can also be I<sup>2</sup>C, and the TMUX121 will still support it.

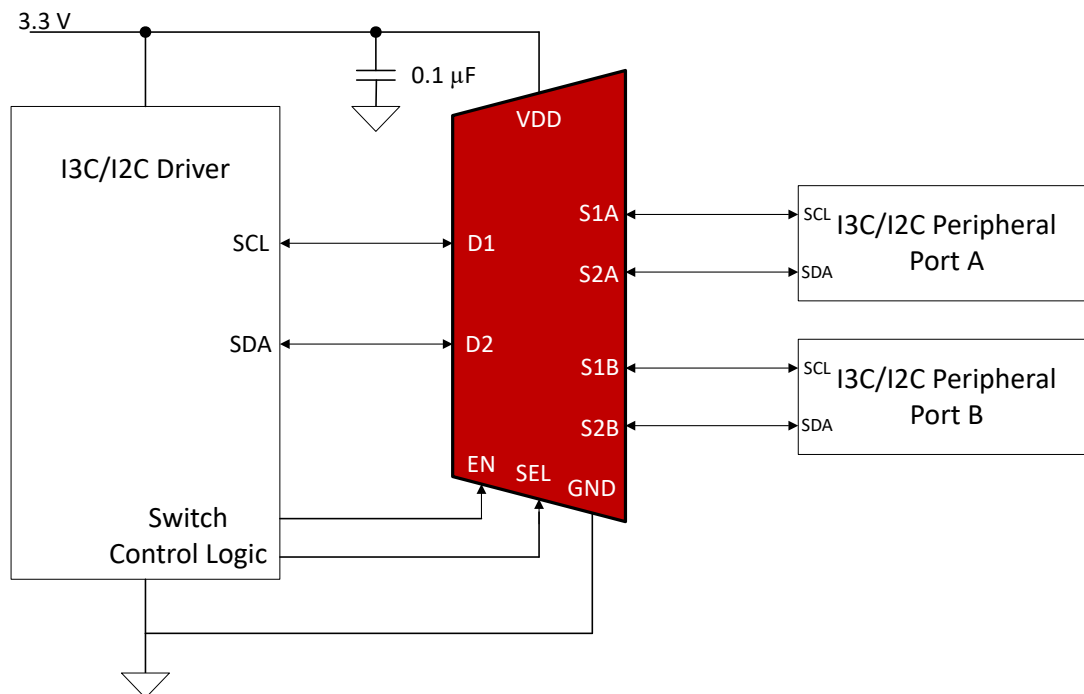

Figure 8-1. Typical Application

### 8.2.1.1 Design Requirements

**Table 8-1. TMUX121 I<sup>3</sup>C Compatibility**

	I <sup>3</sup> C Requirements	TMUX121 Specification
Voltage	1.0 V, 1.2 V, 1.8 V, 3.3 V	0-3.6 V
Frequency	Up to 12.5 MHz	3 GHz Bandwidth
Capacitance	50 pF maximum bus capacitance	< 2 pF On or Off Capacitance

### 8.2.1.2 Detailed Design Procedure

The TMUX121 supports I<sup>3</sup>C standard by maintaining signal integrity through the switch. Table 8-1 details how the TMUX121 specifications make this device optimal for switching I<sup>3</sup>C signals. Choosing a multiplexer with very low capacitance helps reduce the impact to your total capacitance budget. This can enable more design flexibility keeping the total bus capacitance under 50 pF such as: longer traces, more ICs, multiple buses, and so forth.

### 8.2.1.3 Application Curves

Figure 8-2 shows bandwidth of the TMUX121. This can easily support the max data rate of the I<sup>3</sup>C standard. A combination of low on-resistance, low capacitance, and low added jitter from the device allows it to be used for I<sup>3</sup>C.

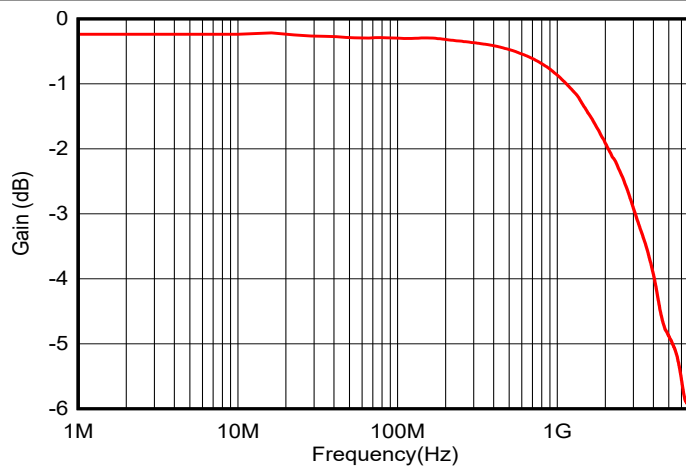

**Figure 8-2. Typical Differential Bandwidth vs Frequency**

## 8.3 Power Supply Recommendations

The TMUX121 does not require a power supply sequence. However, TI recommends to enable the device after VDD is stable and in specification. TI also recommends placing a bypass capacitor as close to the supply pin VDD as possible to help smooth out lower frequency noise to provide better load regulation across the frequency spectrum.

## 8.4 Layout

### 8.4.1 Layout Guidelines

Place supply bypass capacitors as close to VDD pin as possible and avoid placing the bypass capacitors near the high speed traces.

Route the high-speed signals using a minimum of vias and corners which reduces signal reflections and impedance changes. When a via must be used, increase the clearance size around it to minimize its capacitance. Each via introduces discontinuities in the signal's transmission line and increases the chance of picking up interference from the other layers of the board. Be careful when designing test points on twisted pair lines; through-hole pins are not recommended.

When it becomes necessary to turn 90°, use two 45° turns or an arc instead of making a single 90° turn. Doing this reduces reflections on the signal traces by minimizing impedance discontinuities. Avoid stubs on the high-speed signals because they cause signal reflections. Route all high-speed signal traces over continuous planes (VDD or GND) with no interruptions.

Due to high frequencies, a printed circuit board with at least four layers is recommended; two signal layers separated by a ground and power layer as shown in [Figure 8-3](#).

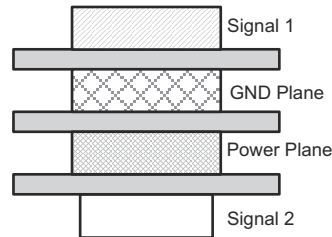
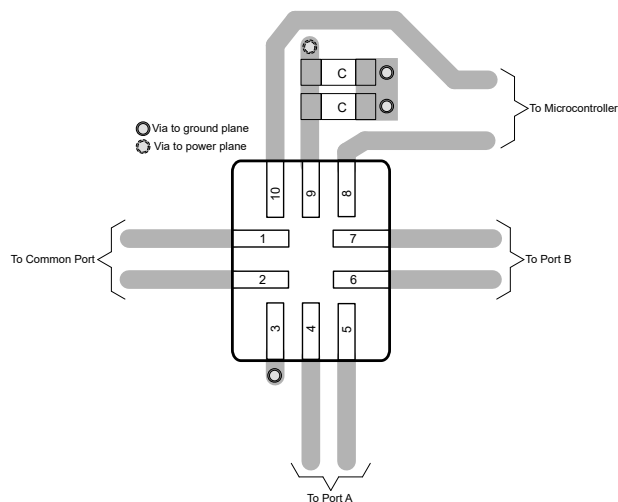

**Figure 8-3. Four-Layer Board Stack-Up**

The majority of signal traces must run on a single layer, preferably Signal 1. Immediately next to this layer must be the GND plane, which is solid with no cuts. Avoid running signal traces across a split in the ground or power plane. When running across split planes is unavoidable, sufficient decoupling must be used. Minimizing the number of signal vias reduces EMI by reducing inductance at high frequencies.

For high speed layout guidelines, refer to [High-Speed Layout Guidelines application note](#).

### 8.4.2 Layout Example



**Figure 8-4. TMUX121 Layout Example**

## 9 Device and Documentation Support

### 9.1 Related Documentation

For related documentation, see the following:

- Texas Instruments, [High-Speed Layout Guidelines application note](#)

### 9.2 Receiving Notification of Documentation Updates

To receive notification of documentation updates, navigate to the device product folder on [ti.com](#). Click on *Subscribe to updates* to register and receive a weekly digest of any product information that has changed. For change details, review the revision history included in any revised document.

### 9.3 Support Resources

[TI E2E™ support forums](#) are an engineer's go-to source for fast, verified answers and design help — straight from the experts. Search existing answers or ask your own question to get the quick design help you need.

Linked content is provided "AS IS" by the respective contributors. They do not constitute TI specifications and do not necessarily reflect TI's views; see TI's [Terms of Use](#).

### 9.4 Trademarks

TI E2E™ is a trademark of Texas Instruments.

All trademarks are the property of their respective owners.

### 9.5 Electrostatic Discharge Caution



This integrated circuit can be damaged by ESD. Texas Instruments recommends that all integrated circuits be handled with appropriate precautions. Failure to observe proper handling and installation procedures can cause damage.

ESD damage can range from subtle performance degradation to complete device failure. Precision integrated circuits may be more susceptible to damage because very small parametric changes could cause the device not to meet its published specifications.

### 9.6 Glossary

[TI Glossary](#) This glossary lists and explains terms, acronyms, and definitions.

## 10 Mechanical, Packaging, and Orderable Information

The following pages include mechanical, packaging, and orderable information. This information is the most current data available for the designated devices. This data is subject to change without notice and revision of this document. For browser-based versions of this data sheet, refer to the left-hand navigation.

**PACKAGING INFORMATION**

Orderable Device	Status (1)	Package Type	Package Drawing	Pins	Package Qty	Eco Plan (2)	Lead finish/ Ball material (6)	MSL Peak Temp (3)	Op Temp (°C)	Device Marking (4/5)	Samples
TMUX121NKGR	ACTIVE	UQFN	NKG	10	3000	RoHS & Green	NIPDAU	Level-1-260C-UNLIM	-40 to 125	OJ	Samples

(1) The marketing status values are defined as follows:

**ACTIVE:** Product device recommended for new designs.

**LIFEBUY:** TI has announced that the device will be discontinued, and a lifetime-buy period is in effect.

**NRND:** Not recommended for new designs. Device is in production to support existing customers, but TI does not recommend using this part in a new design.

**PREVIEW:** Device has been announced but is not in production. Samples may or may not be available.

**OBSELETE:** TI has discontinued the production of the device.

(2) **RoHS:** TI defines "RoHS" to mean semiconductor products that are compliant with the current EU RoHS requirements for all 10 RoHS substances, including the requirement that RoHS substance do not exceed 0.1% by weight in homogeneous materials. Where designed to be soldered at high temperatures, "RoHS" products are suitable for use in specified lead-free processes. TI may reference these types of products as "Pb-Free".

**RoHS Exempt:** TI defines "RoHS Exempt" to mean products that contain lead but are compliant with EU RoHS pursuant to a specific EU RoHS exemption.

**Green:** TI defines "Green" to mean the content of Chlorine (Cl) and Bromine (Br) based flame retardants meet JS709B low halogen requirements of <=1000ppm threshold. Antimony trioxide based flame retardants must also meet the <=1000ppm threshold requirement.

(3) MSL, Peak Temp. - The Moisture Sensitivity Level rating according to the JEDEC industry standard classifications, and peak solder temperature.

(4) There may be additional marking, which relates to the logo, the lot trace code information, or the environmental category on the device.

(5) Multiple Device Markings will be inside parentheses. Only one Device Marking contained in parentheses and separated by a "~" will appear on a device. If a line is indented then it is a continuation of the previous line and the two combined represent the entire Device Marking for that device.

(6) Lead finish/Ball material - Orderable Devices may have multiple material finish options. Finish options are separated by a vertical ruled line. Lead finish/Ball material values may wrap to two lines if the finish value exceeds the maximum column width.

**Important Information and Disclaimer:**The information provided on this page represents TI's knowledge and belief as of the date that it is provided. TI bases its knowledge and belief on information provided by third parties, and makes no representation or warranty as to the accuracy of such information. Efforts are underway to better integrate information from third parties. TI has taken and continues to take reasonable steps to provide representative and accurate information but may not have conducted destructive testing or chemical analysis on incoming materials and chemicals. TI and TI suppliers consider certain information to be proprietary, and thus CAS numbers and other limited information may not be available for release.

In no event shall TI's liability arising out of such information exceed the total purchase price of the TI part(s) at issue in this document sold by TI to Customer on an annual basis.

**TAPE AND REEL INFORMATION**

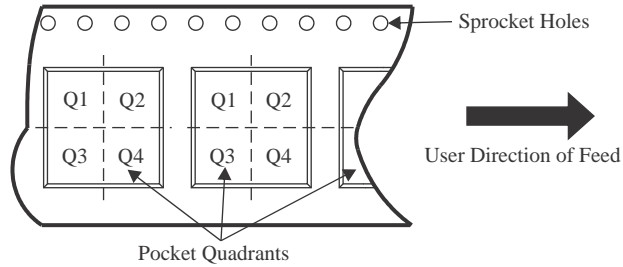
**QUADRANT ASSIGNMENTS FOR PIN 1 ORIENTATION IN TAPE**

\*All dimensions are nominal

Device	Package Type	Package Drawing	Pins	SPQ	Reel Diameter (mm)	Reel Width W1 (mm)	A0 (mm)	B0 (mm)	K0 (mm)	P1 (mm)	W (mm)	Pin1 Quadrant
TMUX121NKGR	UQFN	NKG	10	3000	180.0	8.4	1.6	2.0	0.7	4.0	8.0	Q1

**TAPE AND REEL BOX DIMENSIONS**



\*All dimensions are nominal

Device	Package Type	Package Drawing	Pins	SPQ	Length (mm)	Width (mm)	Height (mm)
TMUX121NKGR	UQFN	NKG	10	3000	210.0	185.0	35.0



# EXAMPLE BOARD LAYOUT

NKG0010A

UQFN - 0.55 mm max height

PLASTIC QUAD FLATPACK - NO LEAD

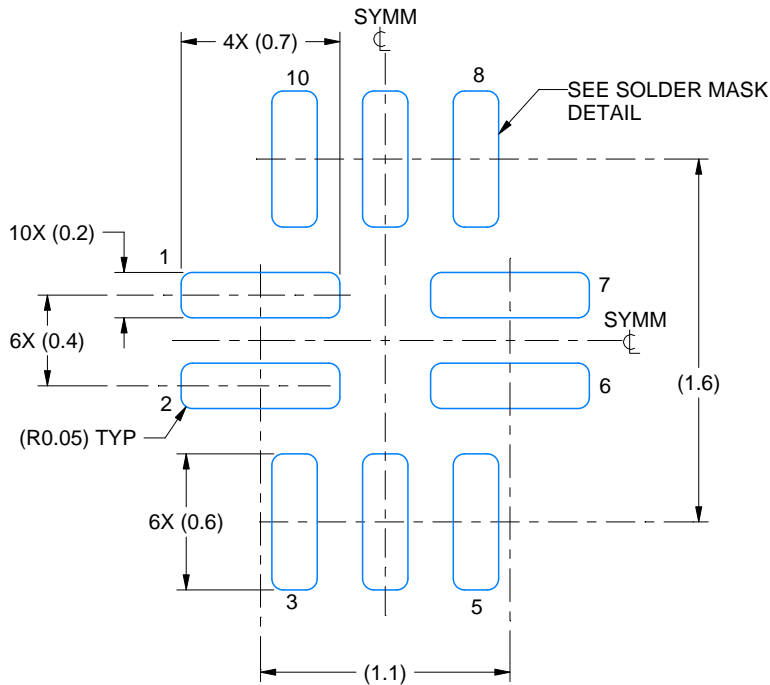

LAND PATTERN EXAMPLE  
EXPOSED METAL SHOWN  
SCALE: 30X

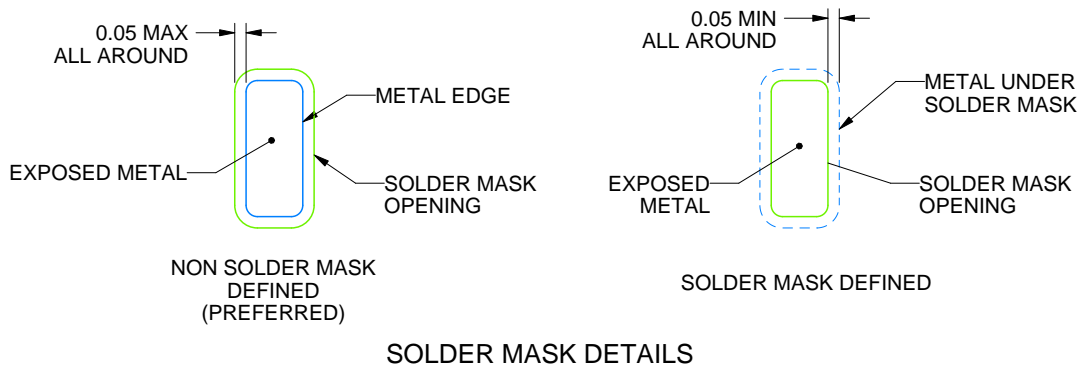

4228479/A 02/2022

NOTES: (continued)

- This package is designed to be soldered to a thermal pad on the board. For more information, see Texas Instruments literature number SLUA271 ([www.ti.com/lit/slua271](http://www.ti.com/lit/slua271)).
- Vias are optional depending on application, refer to device data sheet. If any vias are implemented, refer to their locations shown on this view. It is recommended that vias under paste be filled, plugged or tented.

# EXAMPLE STENCIL DESIGN

NKG0010A

UQFN - 0.55 mm max height

PLASTIC QUAD FLATPACK - NO LEAD

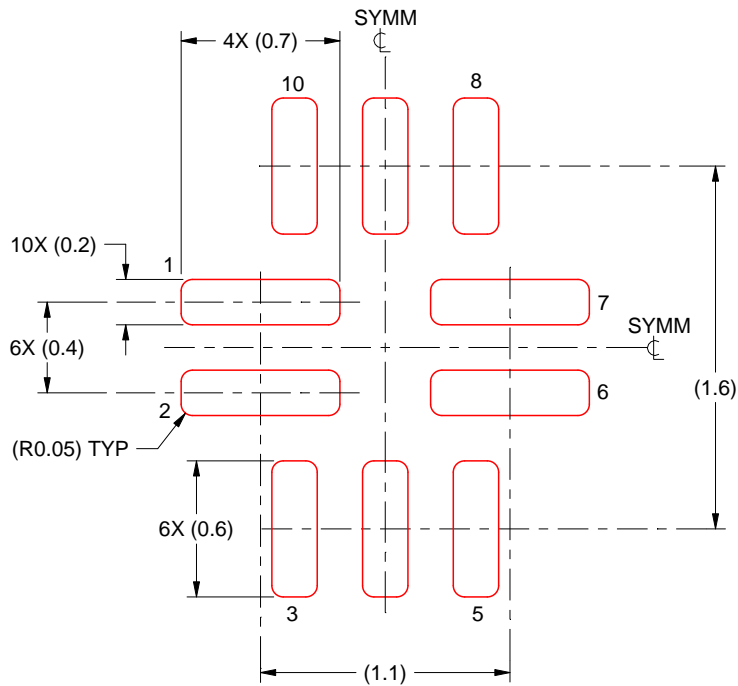

SOLDER PASTE EXAMPLE  
BASED ON 0.1 MM THICK STENCIL  
SCALE: 30X

4228479/A 02/2022

NOTES: (continued)

6. Laser cutting apertures with trapezoidal walls and rounded corners may offer better paste release. IPC-7525 may have alternate design recommendations.

## IMPORTANT NOTICE AND DISCLAIMER

TI PROVIDES TECHNICAL AND RELIABILITY DATA (INCLUDING DATA SHEETS), DESIGN RESOURCES (INCLUDING REFERENCE DESIGNS), APPLICATION OR OTHER DESIGN ADVICE, WEB TOOLS, SAFETY INFORMATION, AND OTHER RESOURCES "AS IS" AND WITH ALL FAULTS, AND DISCLAIMS ALL WARRANTIES, EXPRESS AND IMPLIED, INCLUDING WITHOUT LIMITATION ANY IMPLIED WARRANTIES OF MERCHANTABILITY, FITNESS FOR A PARTICULAR PURPOSE OR NON-INFRINGEMENT OF THIRD PARTY INTELLECTUAL PROPERTY RIGHTS.

These resources are intended for skilled developers designing with TI products. You are solely responsible for (1) selecting the appropriate TI products for your application, (2) designing, validating and testing your application, and (3) ensuring your application meets applicable standards, and any other safety, security, regulatory or other requirements.

These resources are subject to change without notice. TI grants you permission to use these resources only for development of an application that uses the TI products described in the resource. Other reproduction and display of these resources is prohibited. No license is granted to any other TI intellectual property right or to any third party intellectual property right. TI disclaims responsibility for, and you will fully indemnify TI and its representatives against, any claims, damages, costs, losses, and liabilities arising out of your use of these resources.

TI's products are provided subject to [TI's Terms of Sale](#) or other applicable terms available either on [ti.com](https://www.ti.com) or provided in conjunction with such TI products. TI's provision of these resources does not expand or otherwise alter TI's applicable warranties or warranty disclaimers for TI products.

TI objects to and rejects any additional or different terms you may have proposed.

Mailing Address: Texas Instruments, Post Office Box 655303, Dallas, Texas 75265  
Copyright © 2024, Texas Instruments Incorporated

## Looking for pricing, stock, or lifecycle information?

Click below to explore more details on WIN SOURCE:

 [View TMUX121NKGR on WIN SOURCE](#)

 [Texas Instruments](#) Information

## Optimize Your Supply Chain with WIN SOURCE Solutions

-  Global Sourcing Solution
-  Obsolete Management
-  Cost Control Management
-  Shortage Management
-  Alternative Solution
-  Excess Inventory Management