



**THE DATASHEET OF  
M251LD2AE**



**NuMicro<sup>®</sup> Family**  
**Arm<sup>®</sup> Cortex<sup>®</sup> -M23-based Microcontroller**

**M251/M252 Series**  
**Datasheet**

*The information described in this document is the exclusive intellectual property of Nuvoton Technology Corporation and shall not be reproduced without permission from Nuvoton.*

*Nuvoton is providing this document only for reference purposes of NuMicro<sup>®</sup> microcontroller and microprocessor based system design. Nuvoton assumes no responsibility for errors or omissions.*

*All data and specifications are subject to change without notice.*

For additional information or questions, please contact: Nuvoton Technology Corporation.

[www.nuvoton.com](http://www.nuvoton.com)

**TABLE OF CONTENTS**

**1 GENERAL DESCRIPTION ..... 12**

**2 FEATURES ..... 14**

    2.1 M251/M252 Series Features ..... 14

**3 PARTS INFORMATION ..... 29**

    3.1 Package Type ..... 29

    3.2 M251/M252 Series Selection Guide ..... 30

        3.2.1 M251 Base Series (M251Fx / M0251Ex / M0251Zx) ..... 30

        3.2.2 M251 Base Series (M251Lx) ..... 31

        3.2.3 M251 Base Series (M251Sx) ..... 32

        3.2.4 M251 Base Series (M251Kx) ..... 33

        3.2.5 M252 USB Series (M252Fx / M0252Ex / M0252Zx) ..... 34

        3.2.6 M252 USB Series (M252Lx) ..... 35

        3.2.7 M252 USB Series (M252Sx) ..... 36

        3.2.8 M252 USB Series (M252Kx) ..... 37

        3.2.9 Naming Rule ..... 38

**4 PIN CONFIGURATION ..... 39**

    4.1 Pin Configuration ..... 39

        4.1.1 M251 Series Pin Diagram ..... 39

        4.1.2 M251 Series Multi-function Pin Diagram ..... 45

        4.1.3 M252 Series Pin Diagram ..... 80

        4.1.4 M252 Series Function Pin Diagram ..... 86

    4.2 Pin Mapping ..... 121

    4.3 Pin Function Description ..... 126

**5 BLOCK DIAGRAM ..... 132**

    5.1 M251/M252 Block Diagram ..... 132

**6 FUNCTIONAL DESCRIPTION ..... 133**

    6.1 Arm® Cortex®-M23 Core ..... 133

    6.2 System Manager ..... 135

        6.2.1 Overview ..... 135

        6.2.2 System Reset ..... 135

        6.2.3 System Power Distribution ..... 141

        6.2.4 Power Modes and Wake-up Sources ..... 142

        6.2.5 Chip Bus Matrix ..... 146

        6.2.6 System Memory Map ..... 146

        6.2.7 SRAM Memory Organization ..... 148

        6.2.8 IRC Auto Trim ..... 149

        6.2.9 UART0\_TXD/USCIO\_DAT0 Modulation with PWM ..... 149

- 6.2.10 System Timer (SysTick)..... 150
- 6.2.11 Nested Vectored Interrupt Controller (NVIC)..... 151
- 6.3 Clock Controller ..... 155
  - 6.3.1 Overview..... 155
  - 6.3.2 Clock Generator..... 157
  - 6.3.3 System Clock and SysTick Clock..... 158
  - 6.3.4 Peripherals Clock ..... 159
  - 6.3.5 Power-down Mode Clock ..... 159
  - 6.3.6 Clock Output..... 160
  - 6.3.7 USB Clock Source..... 161
- 6.4 Flash Memory Controller (FMC) ..... 162
  - 6.4.1 Overview..... 162
  - 6.4.2 Features..... 162
- 6.5 General Purpose I/O (GPIO) ..... 163
  - 6.5.1 Overview..... 163
  - 6.5.2 Features..... 163
- 6.6 PDMA Controller (PDMA)..... 164
  - 6.6.1 Overview..... 164
  - 6.6.2 Features..... 164
- 6.7 Timer Controller (TMR)..... 165
  - 6.7.1 Overview..... 165
  - 6.7.2 Features..... 165
- 6.8 Watchdog Timer (WDT)..... 167
  - 6.8.1 Overview..... 167
  - 6.8.2 Features..... 167
- 6.9 Window Watchdog Timer (WWDT)..... 168
  - 6.9.1 Overview..... 168
  - 6.9.2 Features..... 168
- 6.10 Real Time Clock (RTC)..... 169
  - 6.10.1 Overview..... 169
  - 6.10.2 Features..... 169
- 6.11 Basic PWM Generator and Capture Timer (BPWM)..... 170
  - 6.11.1 Overview..... 170
  - 6.11.2 Features..... 170
- 6.12 PWM Generator and Capture Timer (PWM) ..... 171
  - 6.12.1 Overview..... 171
  - 6.12.2 Features..... 171
- 6.13 UART Interface Controller (UART)..... 173
  - 6.13.1 Overview..... 173
  - 6.13.2 Features..... 173

6.14 Smart Card Host Interface (SC) ..... 175

    6.14.1 Overview ..... 175

    6.14.2 Features ..... 175

6.15 Serial Peripheral Interface (SPI)..... 176

    6.15.1 Overview ..... 176

    6.15.2 Features ..... 176

6.16 Quad Serial Peripheral Interface (QSPI)..... 177

    6.16.1 Overview ..... 177

    6.16.2 Features ..... 177

6.17 I<sup>2</sup>C Serial Interface Controller (I<sup>2</sup>C)..... 178

    6.17.1 Overview ..... 178

    6.17.2 Features ..... 178

6.18 USCI - Universal Serial Control Interface Controller (USCI)..... 179

    6.18.1 Overview ..... 179

    6.18.2 Features ..... 179

6.19 USCI – UART Mode ..... 180

    6.19.1 Overview ..... 180

    6.19.2 Features ..... 180

6.20 USCI - SPI Mode ..... 181

    6.20.1 Overview ..... 181

    6.20.2 Features ..... 181

6.21 USCI - I<sup>2</sup>C Mode ..... 183

    6.21.1 Overview ..... 183

    6.21.2 Features ..... 183

6.22 Programmable Serial IO (PSIO)..... 184

    6.22.1 Overview ..... 184

    6.22.2 Features ..... 184

6.23 External Bus Interface (EBI) ..... 186

    6.23.1 Overview ..... 186

    6.23.2 Features ..... 186

6.24 USB 1.1 Device Controller (USBD) ..... 187

    6.24.1 Overview ..... 187

    6.24.2 Features ..... 187

6.25 CRC Controller (CRC) ..... 188

    6.25.1 Overview ..... 188

    6.25.2 Features ..... 188

6.26 Enhanced 12-bit Analog-to-Digital Converter (EADC) ..... 189

    6.26.1 Overview ..... 189

    6.26.2 Features ..... 189

6.27	Digital to Analog Converter (DAC)	191
6.27.1	Overview	191
6.27.2	Features	191
6.28	Analog Comparator Controller (ACMP)	192
6.28.1	Overview	192
6.28.2	Features	192
6.29	OP Amplifier (OPA)	193
6.29.1	Overview	193
6.29.2	Features	193
6.30	Peripherals Interconnection	194
6.30.1	Overview	194
6.30.2	Peripherals Interconnect Matrix table	194
<b>7</b>	<b>APPLICATION CIRCUIT</b>	<b>195</b>
7.1	Power Supply Scheme	195
7.2	Peripheral Application Scheme	196
<b>8</b>	<b>ELECTRICAL CHARACTERISTICS</b>	<b>197</b>
8.1	Absolute Maximum Ratings	197
8.1.1	Voltage Characteristics	197
8.1.2	Current Characteristics	198
8.1.3	Thermal Characteristics	199
8.1.4	EMC Characteristics	200
8.1.5	Package Moisture Sensitivity (MSL)	202
8.1.6	Soldering Profile	203
8.2	General Operating Conditions	204
8.3	DC Electrical Characteristics	205
8.3.1	Supply Current Characteristics for M251xC/M251xD/M252xC/M252xD	205
8.3.2	Supply Current Characteristics for M251xE/M251xG/M252xE/M252xG	208
8.3.3	On-Chip Peripheral Current Consumption	211
8.3.4	Wakeup Time from Low-Power Modes	212
8.3.5	I/O Current Injection Characteristics	213
8.3.6	I/O DC Characteristics	213
8.4	AC Electrical Characteristics	216
8.4.1	48 MHz Internal High Speed RC Oscillator (HIRC)	216
8.4.2	4 MHz Internal Median Speed RC Oscillator (MIRC)	217
8.4.3	38.4 kHz Internal Low Speed RC Oscillator (LIRC)	218
8.4.4	External 4~32 MHz High Speed Crystal/Ceramic Resonator (HXT) Characteristics	219
8.4.5	External 4~32 MHz High Speed Clock Input Signal Characteristics	222
8.4.6	External 32.768 kHz Low Speed Crystal/Ceramic Resonator (LXT) Characteristics for M251xC/M251xD/M252xC/M252xD	223

8.4.7 External 32.768 kHz Low Speed Crystal/Ceramic Resonator (LXT) Characteristics for M251xE/M251xG/M252xE/M252xG ..... 225

8.4.8 External 32.768 kHz Low Speed Clock Input Signal Characteristics ..... 226

8.4.9 PLL Characteristics ..... 227

8.4.10 I/O AC Characteristics ..... 228

**8.5 Analog Characteristics..... 230**

8.5.1 LDO ..... 230

8.5.2 Reset and Power Control Block Characteristics ..... 230

8.5.3 12-bit SAR Analog to Digital Converter (ADC)..... 232

8.5.4 Analog Comparator Controller (ACMP)..... 235

8.5.5 Digital to Analog Converter (DAC) ..... 236

8.5.6 OP Amplifier (OPA)..... 238

8.5.7 Internal Voltage Reference ..... 239

8.5.8 Temperature Sensor ..... 240

**8.6 Communications Characteristics..... 241**

8.6.1 SPI Dynamic Characteristics ..... 241

8.6.2 SPI - I<sup>2</sup>S Dynamic Characteristics ..... 244

8.6.3 I<sup>2</sup>C Dynamic Characteristics ..... 246

8.6.4 USCI - SPI Dynamic Characteristics ..... 247

8.6.5 USCI-I<sup>2</sup>C Dynamic Characteristics ..... 250

8.6.6 USB Characteristics ..... 251

8.7 Flash DC Electrical Characteristics ..... 252

**9 PACKAGE DIMENSIONS..... 253**

9.1 TSSOP20 (4.4x6.5x0.9 mm<sup>3</sup>) ..... 253

9.2 TSSOP28 (4.4x9.7x1.0 mm<sup>3</sup>) ..... 254

9.3 QFN 33L (5x5x0.8 mm<sup>3</sup>)..... 255

9.4 LQFP 48L (7x7x1.4 mm<sup>3</sup> Footprint 2.0 mm)..... 257

9.5 LQFP 64L (7x7x1.4 mm<sup>3</sup> Footprint 2.0 mm)..... 258

9.6 LQFP 128L (14x14x1.4 mm<sup>3</sup> Footprint 2.0 mm)..... 259

**10 ABBREVIATIONS..... 260**

10.1 Abbreviations..... 260

**11 REVISION HISTORY ..... 262**

**LIST OF FIGURES**

Figure 4.1-1 M251 Series TSSOP 20-pin Diagram..... 39

Figure 4.1-2 M251 Series TSSOP 28-pin Diagram..... 39

Figure 4.1-3 M251 Series QFN 33-pin Diagram ..... 40

Figure 4.1-4 M251 Series LQFP 48-pin Diagram ..... 41

Figure 4.1-5 M251 Series LQFP 64-pin Diagram without  $V_{BAT}$  ..... 42

Figure 4.1-6 M251 Series LQFP 64-pin Diagram with  $V_{BAT}$  ..... 43

Figure 4.1-7 M251 Series LQFP 128-pin Diagram ..... 44

Figure 4.1-8 M251FC2AE Multi-function Pin Diagram..... 45

Figure 4.1-9 M251EC2AE Multi-function Pin Diagram..... 46

Figure 4.1-10 M251ZC2AE Multi-function Pin Diagram..... 48

Figure 4.1-11 M251ZD2AE Function Pin Diagram ..... 50

Figure 4.1-12 M251LC2AE/M251LD2AE Multi-function Pin Diagram ..... 52

Figure 4.1-13 M251LE3AE Multi-function Pin Diagram ..... 55

Figure 4.1-14 M251LG6AE Multi-function Pin Diagram..... 58

Figure 4.1-15 M251SC2AE/M251SD2AE Multi-function Pin Diagram..... 61

Figure 4.1-16 M251SE3AE Multi-function Pin Diagram..... 64

Figure 4.1-17 M251SG6AE Multi-function Pin Diagram ..... 67

Figure 4.1-18 M251KE3AE Multi-function Pin Diagram..... 70

Figure 4.1-19 M251KG6AE Multi-function Pin Diagram ..... 75

Figure 4.1-20 M252 Series TSSOP 20-pin Diagram..... 80

Figure 4.1-21 M252 Series TSSOP 28-pin Diagram..... 80

Figure 4.1-22 M252 Series QFN 33-pin Diagram ..... 81

Figure 4.1-23 M252 Series LQFP 48-pin Diagram ..... 82

Figure 4.1-24 M252 Series LQFP 64-pin Diagram without  $V_{BAT}$  ..... 83

Figure 4.1-25 M252 Series LQFP 64-pin Diagram with  $V_{BAT}$  ..... 84

Figure 4.1-26 M252 Series LQFP 128-pin Diagram ..... 85

Figure 4.1-27 M252FC2AE Function Pin Diagram ..... 86

Figure 4.1-28 M252EC2AE Function Pin Diagram ..... 87

Figure 4.1-29 M252ZC2AE Function Pin Diagram ..... 89

Figure 4.1-30 M252ZD2A Function Pin Diagram..... 91

Figure 4.1-31 M252LC2AE/M252LD2AE Function Pin Diagram ..... 93

Figure 4.1-32 M252LE3AE Function Pin Diagram..... 96

Figure 4.1-33 M252LG6AE Function Pin Diagram ..... 99

Figure 4.1-34 M252SC2AE/M252SD2AE Function Pin Diagram ..... 102

Figure 4.1-35 M252SE3AE Function Pin Diagram ..... 105

Figure 4.1-36 M252SG3AE Function Pin Diagram..... 108

Figure 4.1-37 M252KE3AE Function Pin Diagram ..... 111

Figure 4.1-38 M252KG6AE Function Pin Diagram ..... 116

Figure 5.1-1 M251/M252 Block Diagram ..... 132

Figure 6.1-1 Cortex®-M23 Block Diagram ..... 133

Figure 6.2-1 System Reset Sources ..... 136

Figure 6.2-2 nRESET Reset Waveform ..... 138

Figure 6.2-3 Power-on Reset (POR) Waveform ..... 138

Figure 6.2-4 Low Voltage Reset (LVR) Waveform ..... 139

Figure 6.2-5 Brown-out Detector (BOD) Waveform ..... 140

Figure 6.2-6 NuMicro® M251/M252 Power Distribution Diagram ..... 141

Figure 6.2-7 Power Mode State Machine ..... 143

Figure 6.2-8 SRAM Memory Organization ..... 148

Figure 6.3-1 Clock Generator Global View Diagram ..... 156

Figure 6.3-2 Clock Generator Block Diagram ..... 157

Figure 6.3-3 System Clock Block Diagram ..... 158

Figure 6.3-4 HXT Stop Protect Procedure ..... 159

Figure 6.3-5 SysTick Clock Control Block Diagram ..... 159

Figure 6.3-6 Clock Output Block Diagram ..... 160

Figure 6.3-7 USB Clock Source ..... 161

Figure 6.20-1 SPI Master Mode Application Block Diagram ..... 181

Figure 6.20-2 SPI Slave Mode Application Block Diagram ..... 181

Figure 6.21-1 I<sup>2</sup>C Bus Timing ..... 183

Figure 6.22-1 PSIO Clock Control Diagram (8-bit Pre-scale Counter in Clock Controller) ..... 185

Figure 8.1-1 Soldering profile from J-STD-020C ..... 203

Figure 8.4-1 Typical Crystal Application Circuit ..... 221

Figure 8.4-2 Typical 32.768 kHz Crystal Application Circuit ..... 224

Figure 8.4-3 Typical 32.768 kHz Crystal Application Circuit ..... 226

Figure 8.5-1 Power Ramp Up/Down Condition ..... 231

Figure 8.5-2 Typical Connection with Internal Voltage Reference ..... 239

Figure 8.6-1 SPI Master Mode Timing Diagram ..... 241

Figure 8.6-2 SPI Slave Mode Timing Diagram ..... 243

Figure 8.6-3 I<sup>2</sup>S Master Mode Timing Diagram ..... 244

Figure 8.6-4 I<sup>2</sup>S Slave Mode Timing Diagram ..... 245

Figure 8.6-5 I<sup>2</sup>C Timing Diagram ..... 246

Figure 8.6-6 USCI-SPI Master Mode Timing Diagram ..... 247

Figure 8.6-7 USCI-SPI Slave Mode Timing Diagram ..... 249

Figure 8.6-8 USCI-I<sup>2</sup>C Timing Diagram ..... 250

**List of Tables**

Table 1-1 NuMicro® M251/M252 Series Key Features Support Table ..... 13

Table 4.1-1 M251FC2AE Multi-function Pin Table..... 45

Table 4.1-2 M251EC2AE Multi-function Pin Table ..... 47

Table 4.1-3 M251ZC2AE Multi-function Pin Table..... 49

Table 4.1-4 M251ZD2AE Multi-function Pin Table..... 51

Table 4.1-5 M251LC2AE/M251LD2AE Multi-function Pin Table ..... 54

Table 4.1-6 M251LE3AE Multi-function Pin Table ..... 57

Table 4.1-7 M251LG6AE Multi-function Pin Table..... 60

Table 4.1-8 M251SC2AE/M251SD2AE Multi-function Pin Table ..... 63

Table 4.1-9 M251SE3AE Multi-function Pin Table..... 66

Table 4.1-10 M251SG6AE Multi-function Pin Table ..... 69

Table 4.1-11 M251KE3AE Multi-function Pin Table..... 74

Table 4.1-12 M251KG6AE Multi-function Pin Table ..... 79

Table 4.1-13 M252FC2AE Multi-function Pin Table..... 87

Table 4.1-14 M252EC2AE Multi-function Pin Table ..... 88

Table 4.1-15 M252ZC2AE Multi-function Pin Table..... 90

Table 4.1-16 M252ZD2AE Multi-function Pin Table..... 92

Table 4.1-17 M252LC2AE/M252LD2AE Multi-function Pin Table ..... 95

Table 4.1-18 M252LE3AE Multi-function Pin Table ..... 98

Table 4.1-19 M252LG6AE Multi-function Pin Table..... 101

Table 4.1-20 M252SC2AE/M252SD2AE Multi-function Pin Table ..... 104

Table 4.1-21 M252SE3AE Multi-function Pin Table..... 107

Table 4.1-22 M252SG6AE Multi-function Pin Table ..... 110

Table 4.1-23 M252KE3AE Multi-function Pin Table..... 115

Table 4.1-24 M252KG6AE Multi-function Pin Table ..... 120

Table 6.2-1 Reset Value of Registers ..... 138

Table 6.2-2 Power Mode Table..... 142

Table 6.2-3 Power Mode Difference Table ..... 142

Table 6.2-4 Power Mode Difference Table ..... 143

Table 6.2-5 Clocks in Power Modes ..... 144

Table 6.2-6 Condition of Entering Power-down Mode Again..... 146

Table 6.2-7 Address Space Assignments for On-Chip Controllers..... 147

Table 6.2-8 Exception Model ..... 152

Table 6.2-9 Interrupt Number Table..... 154

Table 6.13-1 UART Feature List ..... 174

Table 6.30-1 Peripherals Interconnect Matrix Table ..... 194

Table 8.1-1 Voltage Characteristics ..... 197

Table 8.1-2 Current Characteristics ..... 198

Table 8.1-3 Thermal Characteristics ..... 199

Table 8.1-4 EMC Characteristics for M251xC/M251xD/M252xC/M252xD ..... 200

Table 8.1-5 EMC Characteristics for M251xE/M251xG/M252xE/M252xG ..... 201

Table 8.1-6 Package Moisture Sensitivity(MSL) ..... 202

Table 8.1-7 Soldering Profile..... 203

Table 8.2-1 General Operating Conditions ..... 204

Table 8.3-1 Current Consumption in Normal Run Mode..... 206

Table 8.3-2 Current consumption in Idle Mode ..... 206

Table 8.3-3 Chip Current Consumption in Power-down Mode ..... 207

Table 8.3-4 Current consumption in Normal Run Mode ..... 209

Table 8.3-5 Current Consumption in Idle Mode ..... 209

Table 8.3-6 Chip Current Consumption in Power-down Mode ..... 210

Table 8.3-7 Peripheral Current Consumption ..... 212

Table 8.3-8 Low-power Mode Wakeup Timings ..... 212

Table 8.3-9 I/O Current Injection Characteristics ..... 213

Table 8.3-10 I/O Input Characteristics ..... 213

Table 8.3-11 I/O Output Characteristics ..... 214

Table 8.3-12 nRESET Input Characteristics ..... 215

Table 8.4-1 48 MHz Internal High Speed RC Oscillator(HIRC) Characteristics ..... 216

Table 8.4-2 4 MHz Internal Median Speed RC Oscillator (MIRC) Characteristics ..... 217

Table 8.4-3 38.4 kHz Internal Low Speed RC Oscillator (LIRC) Characteristics..... 218

Table 8.4-4 External 4~32 MHz High Speed Crystal (HXT) Oscillator ..... 219

Table 8.4-5 External 4~32 MHz High Speed Crystal Characteristics ..... 220

Table 8.4-6 External 4~32 MHz High Speed Clock Input Signal ..... 222

Table 8.4-7 External 32.768 kHz Low Speed Crystal (LXT) Oscillator ..... 223

Table 8.4-8 External 32.768 kHz Low Speed Crystal Characteristics ..... 223

Table 8.4-9 External 32.768 kHz Low Speed Crystal (LXT) Oscillator ..... 225

Table 8.4-10 External 32.768 kHz Low Speed Crystal Characteristics ..... 225

Table 8.4-11 External 32.768 kHz Low Speed Clock Input Signal ..... 226

Table 8.4-12 PLL Characteristics..... 227

Table 8.4-13 I/O AC Characteristics ..... 229

Table 8.5-1 Reset and Power Control Unit ..... 231

Table 8.5-2 ADC Characteristics..... 233

Table 8.5-3 ACMP Characteristics..... 235

Table 8.5-4 DAC Characteristics..... 237

Table 8.5-5 OPA Characteristics..... 238

Table 8.5-6 Internal Voltage Reference Characteristics ..... 239

Table 8.5-7 Temperature Sensor Characteristics ..... 240

Table 8.6-1 SPI Master Mode Characteristics ..... 241

Table 8.6-2 SPI Slave Mode Characteristics ..... 242

Table 8.6-3 I<sup>2</sup>S Characteristics ..... 244

Table 8.6-4 I<sup>2</sup>C Characteristics ..... 246

Table 8.6-5 USCI-SPI Master Mode Characteristics ..... 247

Table 8.6-6 USCI-SPI Slave Mode Characteristics ..... 248

Table 8.6-7 USCI-I<sup>2</sup>C Characteristics ..... 250

Table 8.6-8 USB Full-Speed Characteristics ..... 251

Table 8.6-9 USB Full-Speed PHY Characteristics..... 251

Table 8.7-1 Flash Characteristics ..... 252

Table 10.1-1 List of Abbreviations..... 261

## 1 GENERAL DESCRIPTION

The NuMicro® M251/M252 series is a low-power microcontroller platform based on Arm® Cortex®-M23 core for Armv8-M architecture. It runs up to 48 MHz with 32 ~ 256 Kbytes embedded Flash memory and 8 ~ 32 Kbytes embedded SRAM, 4 Kbytes Flash loader memory (LDROM) for In-System Programming (ISP). The 32-bit low-power microcontrollers supports wide supply voltage from 1.75V ~ 5.5V and operating temperature range from -40°C ~ +105°C.

### Low-power Technology for IoT application

The NuMicro® M251/M252 series behaves low power consumption in Normal Run mode 138µA/MHz at 48MHz, Idle mode 60 µA/MHz, Power-down mode 2.5 µA (RTC on, RAM retention), Power-down mode 1.7 µA (RTC off, RAM retention) and Deep Power-down mode. The NuMicro® M251/M252 series integrates RTC with independent V<sub>BAT</sub> voltage source pin to support low power mode with main power off and V<sub>BAT</sub> only. Its low power, wide supply voltage and fast wake-up features make it suitable for battery-powered IoT applications.

### Programmable Serial Interface (PSIO)

The NuMicro® M251/M252 series provides up to 8-channel Nuvoton proprietary interface, named as “Programmable Serial I/O” (PSIO), which is capable of generating specific waveform to emulate arbitrary serial communication protocols to connect with specific peripherals by PSIO hardware engine. PSIO can be treated as extension of popular serial communication standard (UART, SPI, I<sup>2</sup>C, etc.), niche serial communication standard and proprietary protocol (SPI-like protocol for LED-lighting application, etc.). This PSIO hardware engine can simulate comprehensive serial communication protocol with low CPU loading, low control complexity and high timing precision at the same time. High elasticity and flexibility makes PSIO a powerful and useful tool while connecting to diverse peripherals.

### Voltage Adjustable Interface (VAI) - Support 2<sup>nd</sup> I/O voltage without level-shifter

The NuMicro® M251/M252 series integrates Voltage Adjustable Interface (VAI), up to 6 I/O pins to support the 2<sup>nd</sup> I/O voltage from 1.65V ~ 5.5V to save level shifter components while connecting to external devices. These 6 I/O pins can be configured as UART/SPI/ I<sup>2</sup>C bus by software setting.

### eExecute-Only-Memory (XOM) - Protect the intelligent property of developers

The NuMicro® M251/M252 series provides 1-region programable eExecute-Only-Memory (XOM) to secure critical program code. A tamper detection pin is implemented to avoid malicious damage from hacker. The 96-bit Unique Identification (UID) and 128-bit Unique Customer Identification (UCID) are used to enhance the product security.

### Crystal-less USB 2.0 full speed device interface

Part numbers of the M252 series are all based on the M251. It supports a crystal-less USB 2.0 full speed device that can generate precise frequency required by USB protocol without the need of external crystal to reduce the BOM cost and PCB size.

### Rich Pheripherals for comprehensive product application scenarios

The NuMicro® M251/M252 series is equipped with plenty of peripherals such as Timers, Watchdog Timers, RTC, PDMA, External Bus Interface (EBI), UART, Universal Serial Control Interface (USCI), QSPI, SPI/ I<sup>2</sup>S, I<sup>2</sup>C, ISO-7816-3, GPIOs, up to 24 channels of PWM, makes it highly suitable for connecting comprehensive external modules and LED lighting control. The NuMicro® M251/M252 series integrates high performance analog front-end circuit blocks, such as 16 channels of 12-bit 730 kSPS ADC, 12-bit 1 MSPS DAC, analog comparator, operational amplifier, temperature sensor, low voltage reset (LVR) and brown-out detector (BOD) to enhance product performance, reduce external components and form factor simultaneously.

The NuMicro® M251/M252 series provides 28 product types. The package types of the M251/M252 series include TSSOP20 (4.4mm x 6.5mm), TSSOP28 (4.4mmx9.7mm), QFN33 (5mm x 5mm), LQFP48 (7mm x 7mm), LQFP64 (7mm x 7mm) and LQFP128 (14mm x 14mm). Pin-to-pin compatible in same package makes optimizing product features and performance easy.

Nuvoton NuMaker M251/M252 evaluation boards and Nu-Link debugger are available for evaluation and product development. 3rd Party IDEs such as Keil MDK, IAR EWARM and Eclipse IDE with GNU GCC compilers, are also supported.

Product Line	UART	I <sup>2</sup> C	QSPI	SPI/ I <sup>2</sup> S	PSIO	USCI	Timer	PWM	PDMA	EBI	ADC	DAC	ACMP	OPA	USB
M251/M252	3	2	1	1	8	3	4	24	8	1	16	1	2	1	1

Table 1-1 NuMicro® M251/M252 Series Key Features Support Table

The NuMicro® M251/M252 series is suitable for a wide range of applications such as:

- Smart Home / Smart Home Appliance
- Industrial Control / Industrial Automation
- Smart City
- IoT Device
- Security Alarm System
- Electronic Payments
- Communication Modules
- Portable Wireless Data Collector
- Smart Door lock
- Handheld Medical Device
- GPS Location Tracker
- Electronic Shelf Labels (ESL)

## 2 FEATURES

### 2.1 M251/M252 Series Features

#### Core and System

##### Arm® Cortex®-M23 without TrustZone®

- Arm® Cortex®-M23 processor, running up to 48 MHz when  $V_{DD} = 1.75V \sim 5.5V$
- Built-in PMSAv8 Memory Protection Unit (MPU)
- Built-in Nested Vectored Interrupt Controller (NVIC)
- 32-bit Single-cycle hardware multiplier and 32-bit 17-cycle hardware divider
- 24-bit system tick timer
- Supports Programmable and maskable interrupt
- Supports Low Power Sleep mode by WFI and WFE instructions
- Supports single cycle I/O access
- Supports XOM feature with 1 region

##### Low power mode and current

- Low Power mode:
  - Idle mode
- Power-down mode (PD)
  - Fast Wake-up Power-down mode (FWPD)
  - Deep Power-down mode (DPD)

##### Wake-up source and wakeup time

- USCI, RTC, WDT, I<sup>2</sup>C, Timer, UART, BOD, LVR, POR, GPIO, USB, Tamper, ACMP, Debug interface, NMI and Reset pin from Power-down mode or Fast Wake-up Power-down mode
- RTC, Wake-up Timer, LVR, Wake-up pins, Tamper, from Deep Power-down mode

##### Power supply and low voltage detect

- Built-in LDO for wide operating voltage from 1.75V to 5.5V
- Core power voltage: 1.5V
- Brown-out detector
  - With 7 levels: 4.4V/3.7V/3.0V/2.7V/2.4V/2.0V/1.8V
  - Supports Brown-out Interrupt and Reset option
- Low Voltage Reset
  - Threshold voltage levels: 1.55V

##### Cyclic Redundancy Calculation Unit

- Supports four common polynomials CRC-CCITT, CRC-8, CRC-16, and CRC-32
- Programmable order reverse setting for input data and CRC checksum
- Programmable 1's complement setting for input data and CRC

	<ul style="list-style-type: none"> <li>checksum.</li> <li>Supports 8-/16-/32-bit of data width</li> <li>Programmable seed value</li> <li>8-bit write mode: 1-AHB clock cycle operation</li> <li>16-bit write mode: 2-AHB clock cycle operation</li> <li>32-bit write mode: 4-AHB clock cycle operation</li> <li>Supports using PDMA to write data to perform CRC operation</li> </ul>
<b>Voltage Adjustable Interface</b>	<ul style="list-style-type: none"> <li>Supports up to 6 VAI pins</li> <li>User Configurable 1.65V ~ 5.5V I/O Interface with a dedicated power input (V<sub>DDIO</sub>)</li> <li>Supports UART0~1, SPI0~1, I2C0~1, USCI2 and SC0 interface</li> </ul>
<b>Security</b>	<ul style="list-style-type: none"> <li>96-bit Unique ID (UID)</li> <li>128-bit Unique Customer ID (UCID)</li> </ul>
<b>Memories</b>	
<b>Flash</b>	<ul style="list-style-type: none"> <li>Up to 256 KB application ROM (APROM)</li> <li>4 KB Flash for user program loader (LDROM)</li> <li>Up to 48 MHz with zero wait state for consecutive address read access</li> <li>12 bytes User Configuration Block to control system initiation.</li> <li>512B page erase for all embedded Flash</li> <li>32-bit and multi-word Flash programming function.</li> <li>Supports In-System-Programming (ISP), In-Application-Programming (IAP) update embedded Flash memory</li> <li>Supports CRC-32 checksum calculation function</li> <li>Supports Flash all one verification function (hardware can check page erase verify)</li> <li>Hardware external read protection of whole Flash memory by Security Lock Bit</li> <li>Supports XOM feature with 1 region</li> </ul>
<b>SRAM</b>	<ul style="list-style-type: none"> <li>Up to 32 KB embedded SRAM</li> <li>Supports byte-, half-word- and word-access</li> <li>Supports PDMA mode</li> </ul>
<b>Peripheral DMA (PDMA)</b>	<ul style="list-style-type: none"> <li>Up to 8 independent configurable channels for automatic data transfer between memories and peripherals</li> <li>Channel 0 to 5 support stride features</li> </ul>

- Channel 0, 1 support time-out function
- Basic and Scatter-Gather Transfer modes
- Each channel supports circular buffer management using Scatter-Gather Transfer mode
- Two types of priorities modes: Fixed-priority and Round-robin modes
- Transfer data width of 8, 16, and 32 bits
- Single and burst transfer type
- Source and destination address can be increment or fixed
- PDMA transfer count up to 65536
- Request source form software, PSIO, SPI/I<sup>2</sup>S, UART, USCI, EADC, DAC, PWM capture event or TIMER

**Clocks**

**Clock Source**

- Built-in 4.032 MHz internal high speed RC oscillator (MIRC) for system operation
- Built-in 48 MHz internal high speed RC oscillator (HIRC) for system operation
- Built-in 38.4 kHz internal low speed RC oscillator (LIRC) for Watchdog Timer and wake-up operation.
- Built-in 4~32 MHz external high speed crystal oscillator (HXT) for precise timing operation
- Built-in 32.768 kHz external low speed crystal oscillator (LXT) for RTC function and low-power system operation
- Supports one PLL up to 100 MHz for high performance system operation, sourced from HIRC and HXT
- Supports clock on-the-fly switch
- Supports clock failure detection for high/low speed external crystal oscillator
- HXT clock frequency accuracy detector
- Supports exception (NMI) generated once a clock failure detected
- Supports divided clock output

**Timers**

**TIMER mode**

**32-bit Timer**

- 4 sets of 32-bit timers with 24-bit up counters and 8-bit prescale counters
- Independent clock source for each timer
- One-shot, Periodic, Toggle and Continuous Counting operation modes
- Event counting function to count the event from external pin

- 
- Input capture function to capture or reset counter value
  - External capture pin event for interval measurement.
  - External capture pin event to reset 24-bit up counter.
  - Chip wake-up from Idle/Power-down mode if a timer interrupt signal is generated
  - Timer interrupt flag or external capture interrupt flag to trigger BPWM, PWM, EADC, DAC and PDMA.
  - Internal capture triggered source from ACMP output.
  - Inter-Timer trigger capture mode

**PWM mode**

- 16-bit compare register and period register
  - Double buffer for period register and compare register
  - Supports inverse in PWM output
  - PWM interrupt wake-up from system Power-down mode
- 

**BPWM**

- Supports maximum clock frequency up to 96 MHz
  - Each module provides 6 output channels
  - Supports independent mode for BPWM output/Capture input channel
  - Supports 12-bit prescaler from 1 to 4096
  - Supports 16-bit resolution BPWM counter, each module provides 1 BPWM counter
    - Up, down or up/down counter operation type
  - Supports mask function and tri-state enable for each BPWM pin
  - Supports interrupt on the following events:
    - BPWM counter match 0, period value or compared value
  - Supports trigger ADC on the following events:
    - BPWM counter match 0, period value or compared value
  - Capture Function Features
    - Up to 6 capture input channels with 16-bit resolution
    - Supports rising or falling capture condition
    - Supports input rising/falling capture interrupt
    - Supports rising/falling capture with counter reload option
- 

**PWM**

- Supports maximum clock frequency up to 96 MHz
  - Up to two PWM modules; each module provides 6 output channels.
  - Supports independent mode for PWM output/Capture input channel
-

- 
- Supports complementary mode for 3 complementary paired PWM output channel
    - Dead-time insertion with 12-bit resolution
    - Two compared values during one period
  - Supports 12-bit prescaler from 1 to 4096
  - Supports 16-bit resolution PWM counter
    - Up, down or up/down counter operation type
  - Supports mask function and tri-state enable for each PWM pin
  - Supports brake function
    - Brake source from pin and system safety events (clock failed, Brown-out detection and CPU lockup)
    - Noise filter for brake source from pin
    - Edge detect brake source to control brake state until brake interrupt cleared
    - Level detect brake source to auto recover function after brake condition removed
  - Supports interrupt on the following events:
    - PWM counter match 0, period value or compared value
    - Brake condition happened
  - Supports trigger ADC on the following events:
    - PWM counter match 0, period value or compared value
  - Capture Function Features
    - Up to 12 capture input channels with 16-bit resolution
    - Supports rising or falling capture condition
    - Supports input rising/falling capture interrupt
    - Supports rising/falling capture with counter reload option
    - Supports PDMA transfer function for all PWM channels
- 

**Watchdog**

- 20-bit free running up counter for WDT time-out interval
  - Clock sources from LIRC (default), HCLK/2048 or LXT
  - 9 selectable time-out period from 488us ~ 32 sec
  - Able to wake up from Power-down or Idle mode
  - Interrupt or reset selectable on watchdog time-out
  - Selectable WDT reset delay period, including 1026, 130, 18 or 3 WDT\_CLK reset delay period
  - Force WDT enabled after chip power on or reset.
  - WDT time-out wake-up function only if WDT clock source is selected as LIRC or LXT
-

<b>Window Watchdog</b>	<ul style="list-style-type: none"> <li>• Clock sources from HCLK/2048 (default) or LIRC</li> <li>• Window set by 6-bit down counter with 11-bit prescaler</li> <li>• WWDT counter suspends in Idle/Power-down mode</li> <li>• Supports Interrupt</li> </ul>
<b>RTC</b>	<ul style="list-style-type: none"> <li>• Supports external power pin <math>V_{BAT}</math></li> <li>• Software compensation by setting frequency compensate register (FCR), compensated clock accuracy reaches <math>\pm 5\text{ppm}</math> within 5 seconds</li> <li>• RTC counter (second, minute, hour) and calendar counter (day, month, year)</li> <li>• Alarm registers (second, minute, hour, day, month, year)</li> <li>• Selectable 12-hour or 24-hour mode</li> <li>• Automatic leap year recognition</li> <li>• Day of the Week counter</li> <li>• Daylight Saving Time software control</li> <li>• Periodic time tick interrupt with 8 period options 1/128, 1/64, 1/32, 1/16, 1/8, 1/4, 1/2 or 1 second</li> <li>• 1 Hz clock output for RTC calibration</li> <li>• Wake-up from idle mode and power down mode</li> <li>• 32 kHz oscillator gain control</li> <li>• RTC Time Tick and Alarm Match interrupt</li> </ul>
<b>Tamper</b>	<ul style="list-style-type: none"> <li>• 20 bytes spare registers and 1 tamper pin to clear the content of these spare registers</li> <li>• Selectable spare register erase function</li> <li>• Supports Timestamp function</li> </ul>
<b>Analog Interfaces</b>	
<b>EADC</b>	<ul style="list-style-type: none"> <li>• Conversion results held in 19 data registers with valid and overrun indicators.</li> <li>• Analog input voltage: <math>0 \sim V_{REF}</math> (Max to <math>AV_{DD}</math>).</li> <li>• Reference voltage from <math>V_{REF}</math> pin, <math>AV_{DD}</math> or internal <math>V_{REF}</math></li> <li>• 12-bit resolution and 10-bit accuracy guaranteed</li> <li>• Up to 16 single-end analog external input channels</li> <li>• Supports 3 internal channels:             <ul style="list-style-type: none"> <li>- Band-gap VBG output or Internal voltage reference</li> <li>- Temperature sensor input</li> <li>- <math>V_{BAT}</math> voltage measure (<math>V_{BAT}/4</math>)</li> </ul> </li> </ul>

- Four ADC interrupts (ADINT0~3) with individual interrupt vector addresses.
- ADC clock frequency up to 16 MHz.
- Up to 730 kSPS conversion rate.
- Configurable ADC internal sampling time
- Up to 19 sample modules
  - Each of sample module 0~15 which is configurable for ADC converter channel
  - EADC\_CH0~15 and trigger source.
  - Configurable PDMA
  - Configured resolution for 12-bit or 16-bit result
  - Supports Left-adjusted result
  - Averaging and oversampling ( $2^n$  times,  $n=0\sim8$ ) to support up to 16-bit result
  - Sample module 16~18 is fixed for ADC channel 16, 17, 18 input sources as band-gap voltage, temperature sensor, and battery power ( $V_{BAT}/4$ ).
  - Configurable sampling time for each sample module.
  - Conversion results held in 19 data registers with valid and overrun indicators.
- Supports digital comparator to monitor conversion result that can be under or over the compare register setting
- Generate an interrupt when conversion result matches the compare register setting.
- Internal reference voltage source:
  - 1.536V, 2.048V, 2.560V, 3.072V, or 4.096V
- An A/D conversion can be started by:
  - Write 1 to SWTRGn (EADC\_SWTRG[n],  $n = 0\sim18$ )
  - External pin STADC
  - Timer0~3 overflow pulse triggers
  - ADINT0/1 interrupt EOC (End of conversion) pulse triggers
  - PWM triggers
  - BPWM triggers
- Supports PDMA transfer
- Auto turn on/off ADC power at power down or operation mode with wait state

**DAC**

- Analog output voltage:  $0\sim AV_{DD}$
- Supports 12-or 8-bit output mode
- Rail to rail settle time 6us

---

	<ul style="list-style-type: none"> <li>• Up to one 12-bit, 1 MSPS voltage type DAC</li> <li>• Reference voltage from internal reference voltage or <math>V_{REF}</math> pin</li> <li>• Conversion updating rate up to 1 MSPS</li> <li>• Supports voltage output buffer mode and bypass voltage output buffer mode</li> <li>• Supports software and hardware trigger, including Timer0~3 and external trigger pin to start DAC conversion</li> <li>• Supports PDMA mode</li> </ul>
--	---

---

<b>Analog Comparator (ACMP)</b>	<ul style="list-style-type: none"> <li>• Up to two rail-to-rail analog comparators</li> <li>• 4 multiplexed I/O pins at positive node</li> <li>• Negative node:             <ul style="list-style-type: none"> <li>- One I/O pin</li> <li>- Band-gap (V<sub>BG</sub>)</li> <li>- DAC0 output</li> <li>- Comparator Reference Voltage (CRV)</li> </ul> </li> <li>• Programmable propagation speed and low power consumption</li> <li>• Interrupts generated when compare results change (Interrupt event condition programmable)</li> <li>• Supports Power-down Wake-up</li> <li>• Supports triggers for break events and cycle-by-cycle control for PWM</li> <li>• Supports window compare mode and window latch mode</li> <li>• Supports programmable hysteresis window:             <ul style="list-style-type: none"> <li>- 0 mV, 10 mV, 20 mV or 30 mV</li> </ul> </li> </ul>
---------------------------------	---

---

<b>OPA</b>	<ul style="list-style-type: none"> <li>• Analog input voltage: 0~<math>AV_{DD}</math>.</li> <li>• Up to 1 operational amplifier</li> <li>• Supports to use schmitt trigger buffer output for simple comparator function</li> <li>• Supports schmitt trigger buffer output interrupts.</li> </ul>
------------	--

---

<b>Internal Reference Voltage</b>	<ul style="list-style-type: none"> <li>• Internal reference voltage select: 1.536V, 2.048V, 2.560V, 3.072V, 4.096V for EADC, DAC and CRV (comparator reference voltage) reference voltage</li> </ul>
-----------------------------------	--

**Communication Interfaces**

---

<b>UART</b>	<ul style="list-style-type: none"> <li>• Supports up to 3 UARTs: UART0, UART1 and UART2</li> <li>• UART clock source can be from LIRC</li> <li>• UART baud rate clock from LXT(32.768 kHz) with 9600bps in Power-down mode</li> </ul>
-------------	---

---

- Baud rate up to 10 Mbps
- Full-duplex asynchronous communications
- Supports one-wire half-duplex communications
- Separates receive and transmit 16/16 bytes FIFO
- Programmable receiver buffer trigger level
- Hardware auto-flow control (CTS and RTS)
- IrDA (SIR) function
  - Supports 3/16 bit duration for normal mode
- RS-485 9-bit mode and direction control
- UART0 supports LIN function
  - LIN master/slave mode
  - Programmable break generation function for transmitter
  - Break detection function for receiver
- Programmable baud-rate generator up to 1/16 system clock
- 8-bit receiver FIFO time-out detection function
- Programmable transmitting data delay time between the last stop and the next start bit
- Auto-Baud Rate measurement and baud rate compensation function
- Break error, frame error, parity error and receive/transmit FIFO overflow detection function
- Supports RS-485 mode:
  - RS-485 9-bit mode
  - Hardware or software enables to program nRTS pin to control RS-485 transmission direction
  - nCTS, incoming data, Received Data FIFO reached threshold and RS-485 Address Match (AAD mode) wake-up function in Power-down mode.
  - Hardware or software enables to program nRTS pin to control RS-485 transmission direction
- Fully programmable serial-interface:
  - Programmable number of data bit, 5-, 6-, 7-, 8- bit character
  - Programmable parity bit, even, odd, no parity or stick parity bit generation and detection
  - Programmable stop bit, 1, 1.5, or 2 stop bit generation
- Supports PDMA mode

---

**Smart card mode**

**Smart Card Interface**

- ISO 7816-3 T = 0, T = 1 compliant
- EMV2000 compliant

- 
- One ISO 7816-3 port
  - Separates receive/transmit 4 byte entry FIFO for data payloads
  - Programmable transmission clock frequency
  - Programmable receiver buffer trigger level
  - Programmable guard time selection (11 ETU ~ 267 ETU)
  - One 24-bit timer and two 8-bit timers for Answer to Request (ATR) and waiting times processing
  - Supports auto direct / inverse convention function
  - Supports transmitter and receiver error retry and error number limiting function
  - Supports hardware activation sequence process, and the time between PWR on and CLK start is configurable
  - Supports hardware warm reset sequence process
  - Supports hardware deactivation sequence process
  - Supports hardware auto deactivation sequence when the card removal is detected

**UART mode**

- Full duplex, asynchronous communications
- Separates receiving / transmitting 4 bytes entry FIFO for data payloads
- Supports programmable baud rate generator
- Supports programmable receiver buffer trigger level
- Programmable transmitting data delay time between the last stop bit leaving the TX-FIFO and the de-assertion
- Programmable even, odd or no parity bit generation and detection
- Programmable stop bit, 1- or 2- stop bit generation

**SPI**

- 
- Supports Master or Slave mode operation
  - Master and slave mode up to 25 MHz (when chip works at  $V_{DD} = 3.0 \sim 5.5V$ )
  - Supports 2-bit Transfer mode
  - Supports Dual and Quad I/O Transfer mode
  - Configurable bit length of a transaction word from 8 to 32-bit
  - Provides separate 8-level depth transmit and receive FIFO buffers
  - Supports MSB first or LSB first transfer sequence
  - Supports Byte Reorder function
  - Supports Byte or Word Suspend mode
  - Supports PDMA transfer
  - Supports 3-Wire, no slave selection signal, bi-direction interface
-

- 
- Supports one data channel half-duplex transfer
  - Supports receive-only mode
- 

**I<sup>2</sup>C**

- Up to 2 sets of I<sup>2</sup>C devices
  - Master/Slave mode
  - Bidirectional data transfer between masters and slaves
  - Multi-master bus (no central master)
  - 7-bit and 10-bit addressing mode
  - Standard mode (100 kbps), Fast mode (400 kbps) and Fast mode plus (1 Mbps)
  - Arbitration between simultaneously transmitting masters without corruption of serial data on the bus
  - Serial clock synchronization allows devices with different bit rates to communicate via one serial bus
  - Serial clock synchronization can be used as a handshake mechanism to suspend and resume serial transfer
  - Supports 14-bit time-out counter requesting the I<sup>2</sup>C interrupt if the I<sup>2</sup>C bus hangs up and timer-out counter overflows
  - Programmable clocks allow versatile rate control
  - Multiple address recognition (four slave address with mask option)
  - Supports setup/hold time programmable
  - Supports SMBus and PMBus
  - Multi-address Power-down wake-up function
  - Supports PDMA transfer
- 

**SPI Mode**

**SPI/I<sup>2</sup>S**

- Up to 1 set of SPI controller
- Master or Slave mode operation
- Configurable bit length of a transfer word from 8 to 32-bit
- Provides separate 4-level of 32-bit (or 8-level of 16-bit) transmit and receive FIFO buffers which depended on SPI setting of data width
- MSB first or LSB first transfer sequence
- Supports byte reorder function
- Byte or Word Suspend mode
- Master and slave mode up to 25 MHz (V<sub>DD</sub> = 3.0V ~5.5V)
- Supports one data channel half-duplex transfer
- Supports receive-only mode
- Supports PDMA transfer

**I<sup>2</sup>S Mode**

- Up to 1 sets of I<sup>2</sup>S by SPI controllers
- Interface with external audio CODEC
- Supports Master and Slave mode
- Capable of handling 8-, 16-, 24- and 32-bit word sizes
- Mono and stereo audio data
- PCM mode A, PCM mode B, I<sup>2</sup>S and MSB justified data format
- Each provides two 4-level FIFO data buffers, one for transmitting and the other for receiving
- Generates interrupt requests when buffer levels cross a programmable boundary
- Each supports two PDMA requests, one for transmitting and the other for receiving

- Up to 3 sets of USCI: USCI0, USCI1 and USCI2
- Supports UART, SPI and I<sup>2</sup>C function
- Single byte TX and RX buffer mode

**USCI\_UART**

- One transmit buffer and two receive buffer for data payload
- Hardware auto flow control function and programmable flow control trigger level
- Programmable baud-rate generator
- Supports 9-bit data transfer
- Baud rate detection by built-in capture event of baud rate generator
- Supports Wake-up function (Data and nCTS Wakeup Only)
- Supports PDMA transfer

**Universal Serial Control Interface (USCI)**

**USCI\_SPI**

- Master or Slave mode operation
- Configurable bit length of a transfer word from 4 to 16-bit
- One transmit buffer and two receive buffer for data payload
- MSB first or LSB first transfer sequence
- Word suspend function
- Supports PDMA transfer
- Supports 3-wire, no slave select signal, bi-direction interface
- Wake-up function: input slave select transition
- Supports one data channel half-duplex transfer

**USCI\_I2C**

- Full master and slave device capability

	<ul style="list-style-type: none"> <li>• 7-bit/10-bit addressing mode</li> <li>• Communication in Standard mode (100 kbps), Fast mode (up to 400 kbps) and Fast mode plus (1 Mbps)</li> <li>• Multi-master bus</li> <li>• One transmit buffer and two receive buffer for data payload</li> <li>• 10-bit bus time out capability</li> <li>• Supports Bus monitor mode</li> <li>• Wake-up by data toggle or address match in Power-down mode</li> <li>• Multiple address recognition</li> <li>• Setup/hold time programmable</li> </ul>
<p><b>External Bus Interface (EBI)</b></p>	<ul style="list-style-type: none"> <li>• Supports up to three memory banks</li> <li>• Supports dedicated external chip select pin with polarity control for each bank</li> <li>• Accessible space up to 1 Mbytes for each bank</li> <li>• Byte write in 16-bit data width mode</li> <li>• Address/Data multiplexed and separate mode</li> <li>• Timing parameters individual adjustment for each memory block</li> <li>• Supports LCD interface i80 mode</li> <li>• Supports Continuous Data Access mode</li> <li>• Supports PDMA mode</li> </ul>
<p><b>GPIO</b></p>	<ul style="list-style-type: none"> <li>• Four I/O modes:             <ul style="list-style-type: none"> <li>- Quasi bi-direction</li> <li>- Push-Pull output</li> <li>- Open-Drain output</li> <li>- Input only with high impedance</li> </ul> </li> <li>• TTL/Schmitt trigger input selectable</li> <li>• I/O pin configured as interrupt source with edge/level trigger setting</li> <li>• Independent pull-up/pull-down control</li> <li>• High driver and high sink current I/O (up to 16 mA at 5V, 25°C)</li> <li>• Minimum I/O Speed             <ul style="list-style-type: none"> <li>- 25 MHz when <math>V_{DD} = 2.7 \sim 5.5 \text{ V}</math> (-40°C ~ +105°C, CL=35p, high skew rate enabled)</li> <li>- 10 MHz when <math>V_{DD} = 1.75 \sim 5.5 \text{ V}</math> (-40°C ~ +105°C, CL=35p, high skew rate enabled)</li> </ul> </li> <li>• Software selectable slew rate control</li> </ul>

- 
- Supports wake-up function
  - Supports I/O de-bounce with LIRC at power down
  - I/O configurations of multi-function pin are controlled by module or MFOS register settings.
- 

**PSIO**

- Supports up to 8 PSIO pins, from PSIO pin0 to PSIO pin7
  - Supports 6 clock source selections: HXT, LXT, HIRC, LIRC, PLL, or PCLK1
  - Supports one clock divider, which can be divided from 1 to 255
  - Supports slot controller for timing sequence control
    - Supports 4 slot controllers, 8 slots in each slot controller
    - Supports counting from 1 PSIO clock to 15 PSIO clocks in each slot
    - Supports 3 slot repeat modes
      - ◆ Normal repeat mode
      - ◆ Normal repeat mode with infinity loops
      - ◆ Whole repeat mode
    - Supports 4 slot trigger conditions
      - ◆ Triggered by software
      - ◆ Triggered by falling edge
      - ◆ Triggered by rising edge
      - ◆ Triggered by rising edge or falling edge
  - Supports PSIO PIN for pin state control
  - Supports 8 check points to connect with slots in each pin
  - Supports 8 check point actions in each check point.
  - Supports 7 kinds of check point action to setting
    - Output high
    - Output low
    - Output data
    - Output toggle
    - Input data
    - Input status
    - Input status update
  - Supports 4 I/O modes: input, output, open-drain, and quasi
  - Supports switch I/O mode in different check points
  - Supports 4 kinds of Interrupt trigger conditions:
    - Two sets of configurable slot interrupt controllers
    - Mismatch interrupt when PSIO is enabled with PDMA
-

- 
- Transfer Error interrupt
  - Slot controller counting done interrupt
  - Supports PDMA function

---

**Advanced Connectivity**

---

**USB 2.0 Full Speed**

- Compliant with USB 2.0 Full-Speed specification
  - Provides 1 interrupt vector with 4 different interrupt events (NEVWK, VBUSDET, USB and BUS)
  - Suspend function when no bus activity exists for 3 ms
  - Supports 12 endpoints for configurable Control/Bulk/Interrupt/Isochronous transfer types and maximum 1024 bytes buffer size
  - Provides remote wake-up capability
  - Start of Frame (SOF) locked clock pulse generation
  - Supports USB 2.0 Link Power Management (LPM)
  - Supports Crystal-less function
-

**3 PARTS INFORMATION**

**3.1 Package Type**

Package is Halogen-free, RoHS-compliant and TSCA-compliant.

Part No.	TSSOP20	TSSOP28	QFN33	LQFP48	LQFP64	LQFP128
<b>M251xC</b>	M251FC2AE	M251EC2AE	M251ZC2AE	M251LC2AE	M251SC2AE	
<b>M251xD</b>			M251ZD2AE	M251LD2AE	M251SD2AE	
<b>M251xE</b>				M251LE3AE	M251SE3AE	M251KE3AE
<b>M251xG</b>				M251LG6AE	M251SG6AE	M251KG6AE
<b>M252xC</b>	M252FC2AE	M252EC2AE	M252ZC2AE	M252LC2AE	M252SC2AE	
<b>M252xD</b>			M252ZD2AE	M252LD2AE	M252SD2AE	
<b>M252xE</b>				M252LE3AE	M252SE3AE	M252KE3AE
<b>M252xG</b>				M252LG6AE	M252SG6AE	M252KG6AE

3.2 M251/M252 Series Selection Guide

3.2.1 M251 Base Series (M251Fx / M0251Ex / M0251Zx)

PART NUMBER		M251FC2AE	M251EC2AE	M251ZC2AE	M251ZD2AE
Flash (KB)		32	32	32	64
SRAM (KB)		8	8	8	12
LDROM (KB)		4			
PLL ( MHz)		-	-	-	96
LXT		-	-	√	√
I/O		15	23	26	26
32-bit Timer/PWM		4			
PWM		9	11	12	12
BPWM		-	-	-	12
WDT/WWDT		√			
RTC		-	-	√	√
Connectivity	USCI	1	1	1	2
	UART	2	2	2	3
	QSPI	1			
	SPI /I <sup>2</sup> S	-	-	-	1
	I <sup>2</sup> C	2			
	SC/UART	1			
	EBI	-			
	PSIO	-	-	-	4
12-bit ADC		7	9	10	10
ACMP		-	-	-	2
DAC		-			
OPA		-			
PDMA		5			
Tamper		-			
VAI		-	-	√	√
V <sub>BAT</sub> pin		-			
Internal V <sub>REF</sub>		-			
Package		TSSOP20	TSSOP28	QFN33	QFN33

3.2.2 M251 Base Series (M251Lx)

PART NUMBER		M251LC2AE	M251LD2AE	M251LE3AE	M251LG6AE
Flash (KB)		32	64	128	256
SRAM (KB)		8	12	16	32
LDROM (KB)		4			
PLL ( MHz)		96			
LXT		√			
I/O		41			
32-bit Timer/PWM		4			
PWM		12			
BPWM		12			
WDT/WWDT		√			
RTC		√			
Connectivity	USCI	2	2	3	3
	UART	3			
	QSPI	1			
	SPI /I <sup>2</sup> S	1			
	I <sup>2</sup> C	2			
	SC/UART	1			
	EBI	-	-	√	√
	PSIO	4	4	8	8
12-bit ADC		12			
ACMP		2			
DAC		-	-	-	1
OPA		-	-	-	1
PDMA		5	5	8	8
Tamper		-			
VAI		√			
V <sub>BAT</sub> pin		-			
Internal V <sub>REF</sub>		-			
Package		LQFP48			

3.2.3 M251 Base Series (M251Sx)

PART NUMBER		M251SC2AE	M251SD2AE	M251SE3AE	M251SG6AE
Flash (KB)		32	64	128	256
SRAM (KB)		8	12	16	32
LDROM (KB)		4			
PLL ( MHz)		96			
LXT		√			
I/O		54	54	53	53
32-bit Timer/PWM		4			
PWM		12			
BPWM		12			
WDT/WWDT		√			
RTC		√			
Connectivity	USCI	2	2	3	3
	UART	3			
	QSPI	1			
	SPI /I <sup>2</sup> S	1			
	I <sup>2</sup> C	2			
	SC/UART	1			
	EBI	-	-	√	√
	PSIO	4	4	8	8
12-bit ADC		16			
ACMP		2			
DAC		-	-	-	1
OPA		-	-	-	1
PDMA		5	5	8	8
Tamper		√			
VAI		√			
V <sub>BAT</sub> pin		-	-	√	√
Internal V <sub>REF</sub>		√			
Package		LQFP64			

3.2.4 M251 Base Series (M251Kx)

PART NUMBER		M251KE3AE	M251KG6AE
Flash (KB)		128	256
SRAM (KB)		16	32
LDROM (KB)		4	
PLL ( MHz)		96	
LXT		√	
I/O		85	
32-bit Timer/PWM		4	
PWM		12	
BPWM		12	
WDT/WWDT		√	
RTC		√	
Connectivity	USCI	3	
	UART	3	
	QSPI	1	
	SPI /I <sup>2</sup> S	1	
	I <sup>2</sup> C	2	
	SC/UART	1	
	EBI	√	
	PSIO	8	
12-bit ADC		16	
ACMP		2	
DAC		-	1
OPA		-	1
PDMA		8	
Tamper		√	
VAI		√	
V <sub>BAT</sub> pin		√	
Internal V <sub>REF</sub>		√	
Package		LQFP128	

3.2.5 M252 USB Series (M252Fx / M0252Ex / M0252Zx)

PART NUMBER		M252FC2AE	M252EC2AE	M252ZC2AE	M252ZD2AE
Flash (KB)		32	32	32	64
SRAM (KB)		8	8	8	12
LDROM (KB)		4			
PLL ( MHz)		-	-	-	96
LXT		-	-	√	√
I/O		11	19	22	22
32-bit Timer/PWM		4			
PWM		7	11	12	12
BPWM		-	-	-	8
WDT/WWDT		√			
RTC		-	-	√	√
Connectivity	USCI	1	1	1	2
	UART	2	2	2	3
	QSPI	1			
	SPI /I <sup>2</sup> S	-	-	-	1
	I <sup>2</sup> C	2			
	SC/UART	1			
	EBI	-			
	PSIO	-	-	-	4
12-bit ADC		3	9	10	10
ACMP		-	-	-	2
DAC		-			
OPA		-			
PDMA		5			
Tamper		-			
VAI		-	-	√	√
V <sub>BAT</sub> pin		-			
Internal V <sub>REF</sub>		-			
Package		TSSOP20	TSSOP28	QFN33	QFN33

3.2.6 M252 USB Series (M252Lx)

PART NUMBER		M252LC2AE	M252LD2AE	M252LE3AE	M252LG6AE
Flash (KB)		32	64	128	256
SRAM (KB)		8	12	16	32
LDROM (KB)		4			
PLL ( MHz)		96			
LXT		√			
I/O		37			
32-bit Timer/PWM		4			
PWM		12			
BPWM		12			
WDT/WWDT		√			
RTC		√			
Connectivity	USCI	2	2	3	3
	UART	3			
	QSPI	1			
	SPI /I <sup>2</sup> S	1			
	I <sup>2</sup> C	2			
	SC/UART	1			
	EBI	-	-	√	√
	PSIO	4	4	8	8
12-bit ADC		12			
ACMP		2			
DAC		-	-	-	1
OPA		-	-	-	1
PDMA		5	5	8	8
Tamper		-			
VAI		√			
V <sub>BAT</sub> pin		-			
Internal V <sub>REF</sub>		-			
Package		LQFP48			

3.2.7 M252 USB Series (M252Sx)

PART NUMBER		M252SC2AE	M252SD2AE	M252SE3AE	M252SG6AE
Flash (KB)		32	64	128	256
SRAM (KB)		8	12	16	32
LDROM (KB)		4			
PLL ( MHz)		96			
LXT		√			
I/O		50	50	49	49
32-bit Timer/PWM		4			
PWM		12			
BPWM		12			
WDT/WWDT		√			
RTC		√			
Connectivity	USCI	2	2	3	3
	UART	3			
	QSPI	1			
	SPI /I <sup>2</sup> S	1			
	I <sup>2</sup> C	2			
	SC/UART	1			
	EBI	-	-	√	√
	PSIO	4	4	8	8
12-bit ADC		16			
ACMP		2			
DAC		-	-	-	1
OPA		-	-	-	1
PDMA		5	5	8	8
Tamper		√			
VAI		√			
V <sub>BAT</sub> pin		-	-	√	√
Internal V <sub>REF</sub>		√			
Package		LQFP64			

3.2.8 M252 USB Series (M252Kx)

PART NUMBER		M252KE3AE	M252KG6AE
Flash (KB)		128	256
SRAM (KB)		16	32
LDROM (KB)		4	
PLL ( MHz)		96	
LXT		√	
I/O		81	
32-bit Timer/PWM		4	
PWM		12	
BPWM		12	
WDT/WWDT		√	
RTC		√	
Connectivity	USCI	3	
	UART	3	
	QSPI	1	
	SPI /I <sup>2</sup> S	1	
	I <sup>2</sup> C	2	
	SC/UART	1	
	EBI	√	
	PSIO	8	
12-bit ADC		16	
ACMP		2	
DAC		-	1
OPA		-	1
PDMA		8	
Tamper		√	
VAI		√	
V <sub>BAT</sub> pin		√	
Internal V <sub>REF</sub>		√	
Package		LQFP128	

**3.2.9 Naming Rule**

<b>M2</b>	<b>51</b>	<b>S</b>	<b>G</b>	<b>6</b>	<b>A</b>	<b>E</b>
<b>Core</b>	<b>Line</b>	<b>Package</b>	<b>Flash</b>	<b>SRAM</b>	<b>Reserve</b>	<b>Temperature</b>
Cortex®-M23	51: Control 52: USB	F: TSSOP20 (4.4x6.5 mm) E: TSSOP28 (4.4x9.7 mm) Z: QFN33 (5x5 mm) L: LQFP48 (7x7 mm) S: LQFP64 (7x7 mm) K: LQFP128 (14x14 mm)	C: 32 KB D: 64 KB E: 128 KB G: 256 KB	2: 8/12 KB 3: 16 KB 6: 32 KB		E: -40°C ~ +105°C

## 4 PIN CONFIGURATION

Users can find pin configuration information in chapter 4 or by using [NuTool - PinConfig](#). The NuTool - PinConfigure contains all NuMicro® Family chip series with all part number, and helps users configure GPIO multi-function correctly and handily.

### 4.1 Pin Configuration

#### 4.1.1 M251 Series Pin Diagram

##### 4.1.1.1 M251 Series TSSOP 20-Pin Diagram

Corresponding Part Number: M251FC2AE

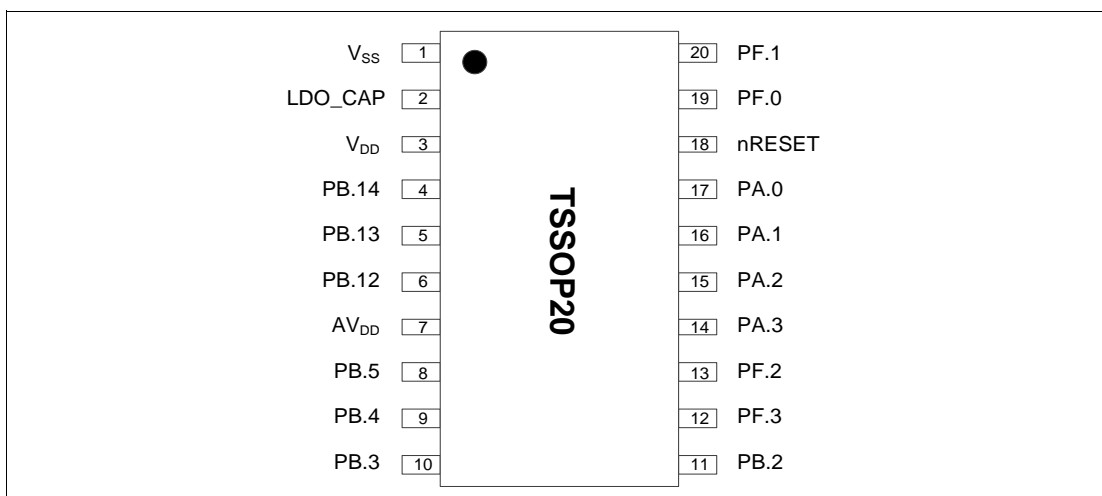

Figure 4.1-1 M251 Series TSSOP 20-pin Diagram

##### 4.1.1.2 M251 Series TSSOP 28-Pin Diagram

Corresponding Part Number: M251EC2AE

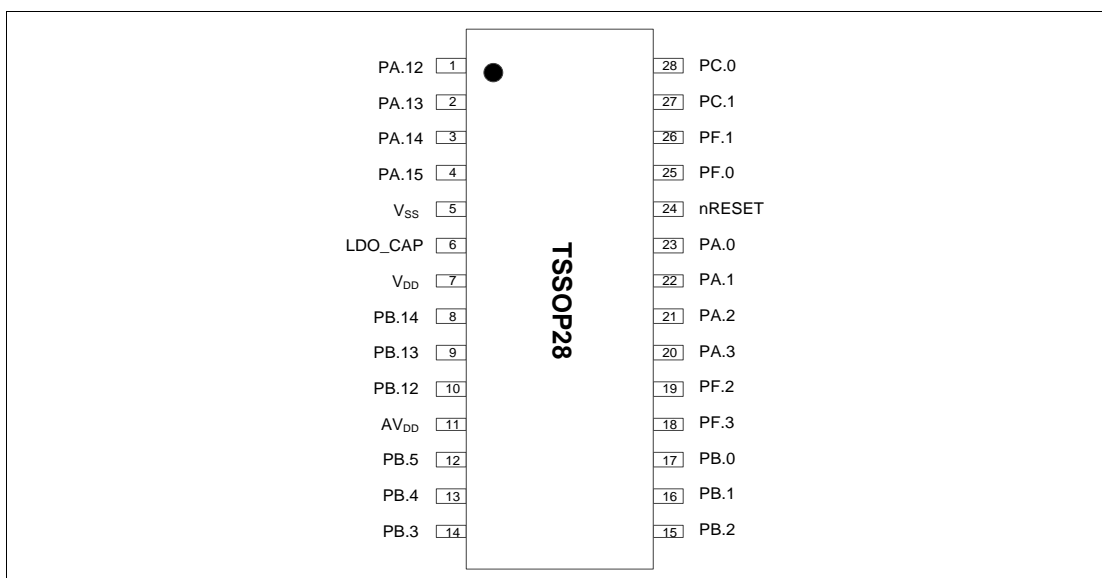

Figure 4.1-2 M251 Series TSSOP 28-pin Diagram

4.1.1.3 M251 Series QFN 33-Pin Diagram

Corresponding Part Number: M251ZC2AE, M251ZD2AE

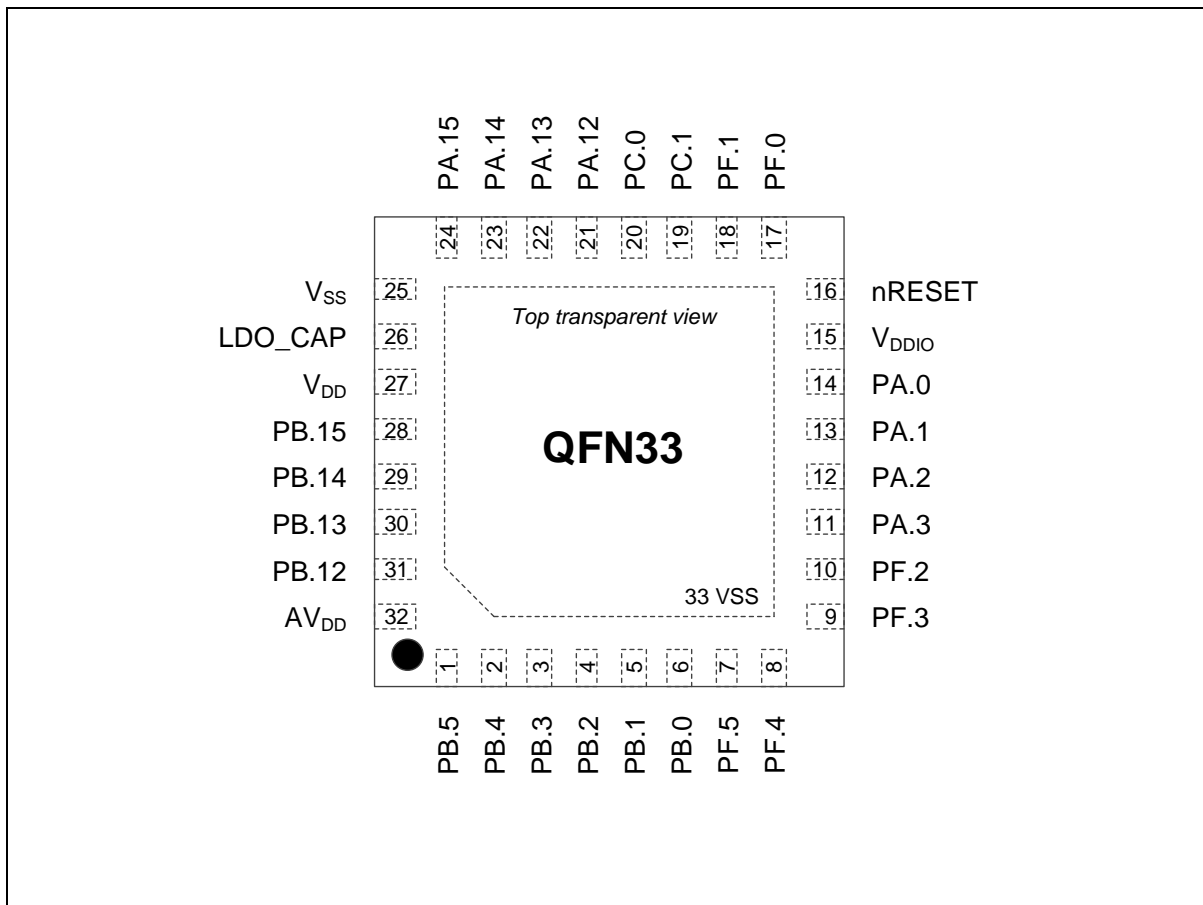

Figure 4.1-3 M251 Series QFN 33-pin Diagram

4.1.1.4 M251 Series LQFP 48-Pin Diagram

Corresponding Part Number: M251LC2AE, M251LD2AE, M251LE3AE, M251LG6AE

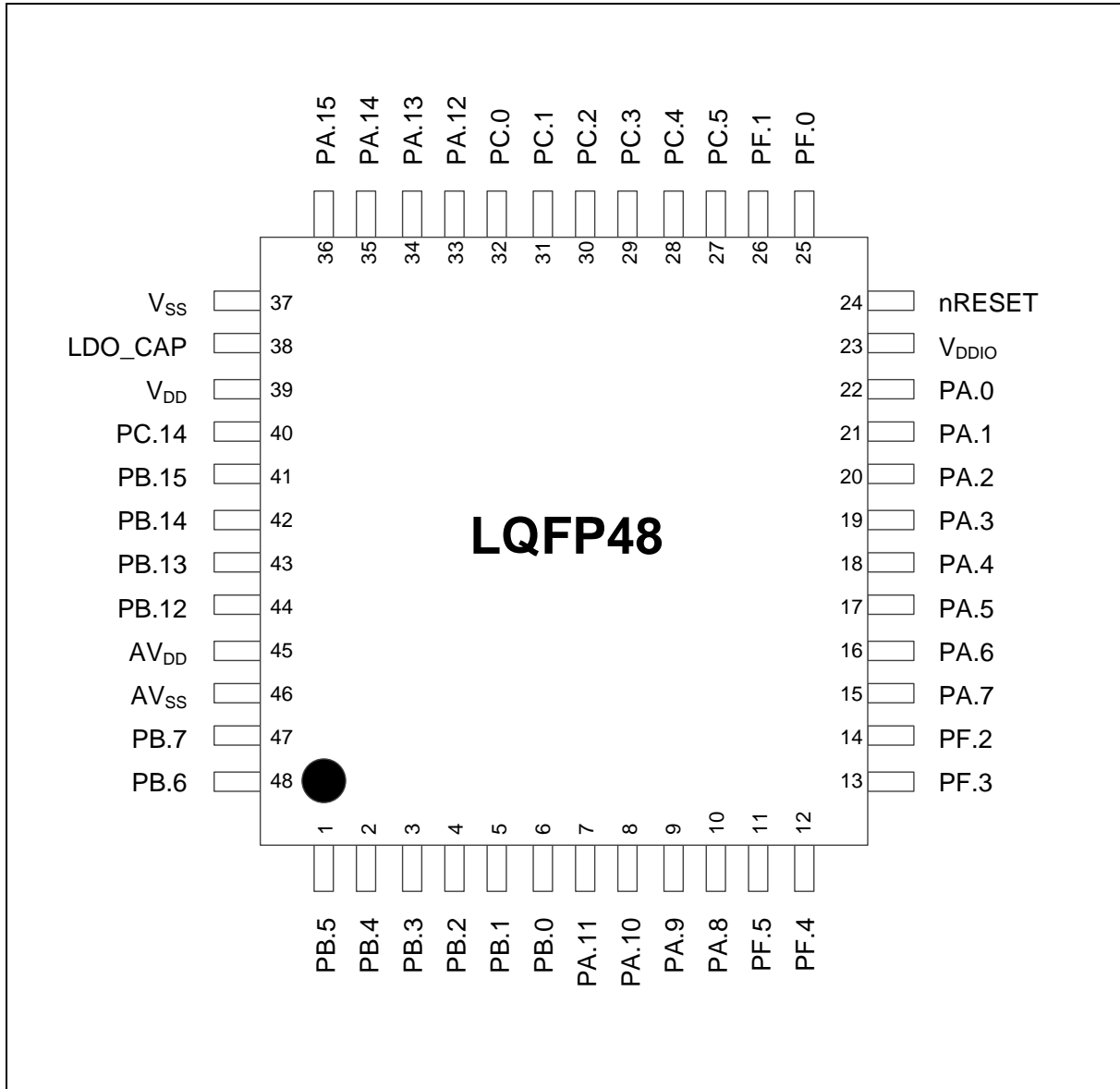

Figure 4.1-4 M251 Series LQFP 48-pin Diagram

4.1.1.5 M251 Series LQFP 64-Pin Diagram

Corresponding Part Number: M251SC2AE, M251SD2AE, M251SE3AE, M251SG6AE

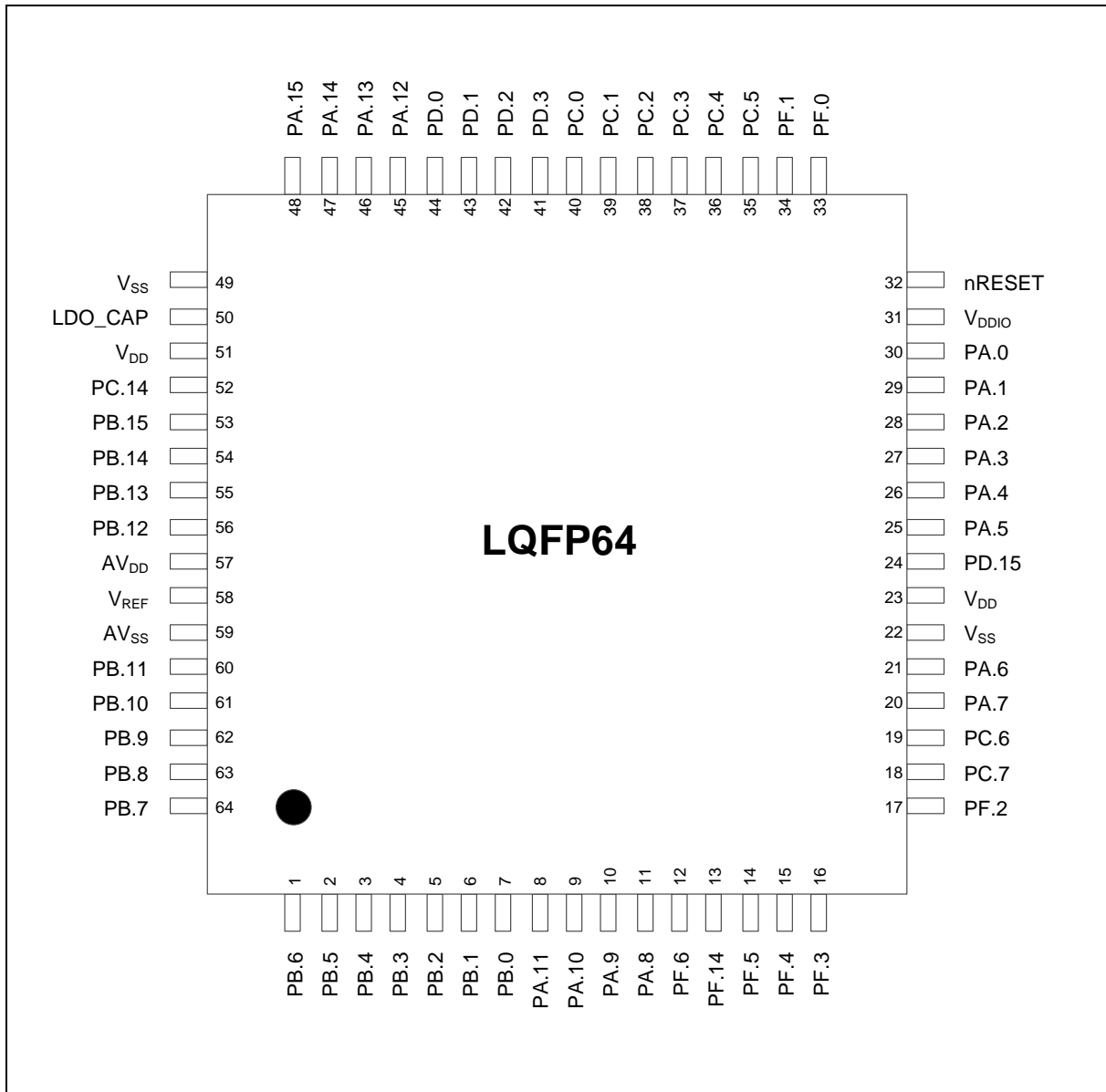

Figure 4.1-5 M251 Series LQFP 64-pin Diagram without V<sub>BAT</sub>

Corresponding Part Number: M251SG6AE, M251SE3AE

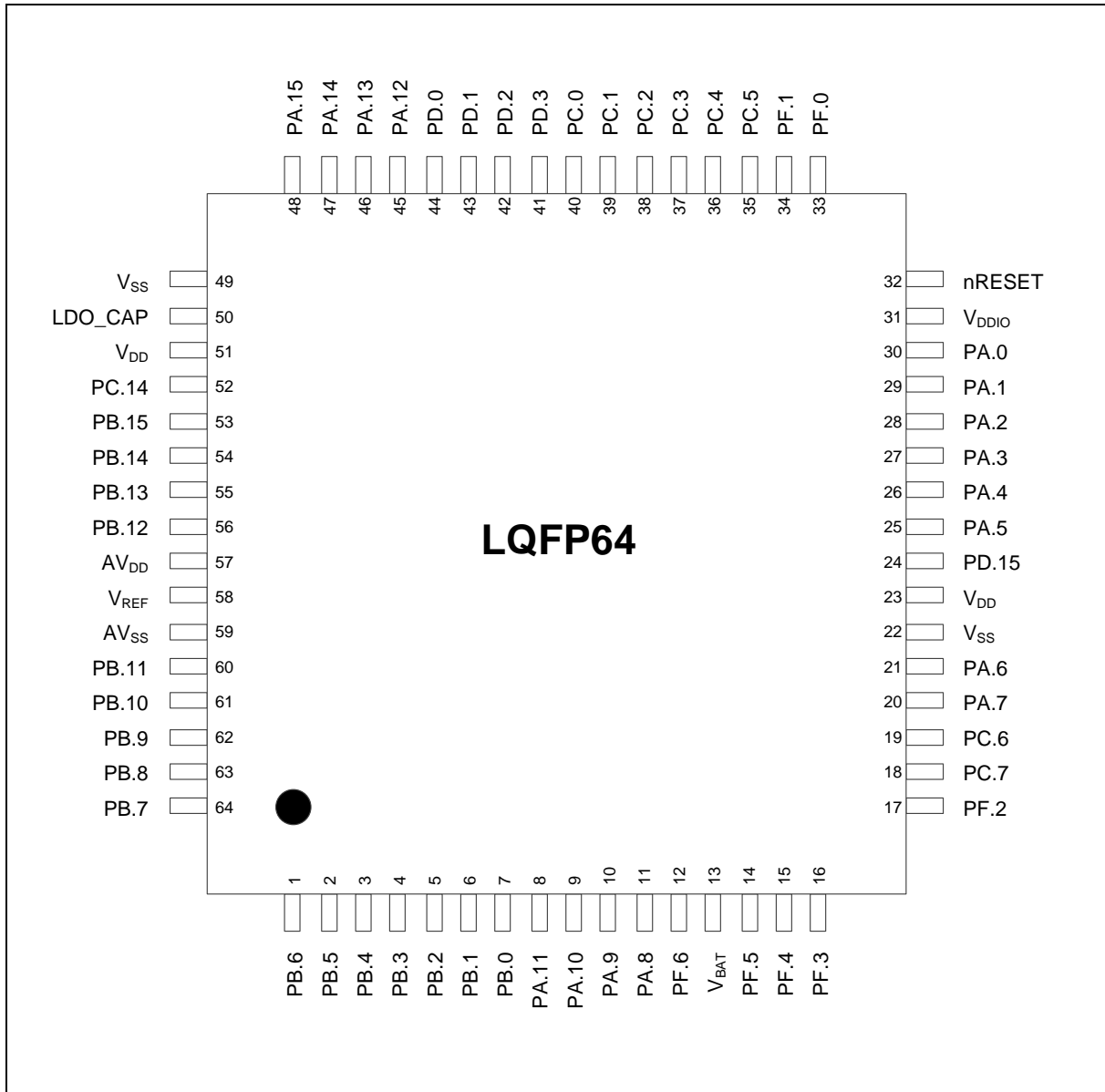

Figure 4.1-6 M251 Series LQFP 64-pin Diagram with V<sub>BAT</sub>

4.1.1.6 M251 Series LQFP 128-Pin Diagram

Corresponding Part Number: M251KE3AE, M251KG6AE

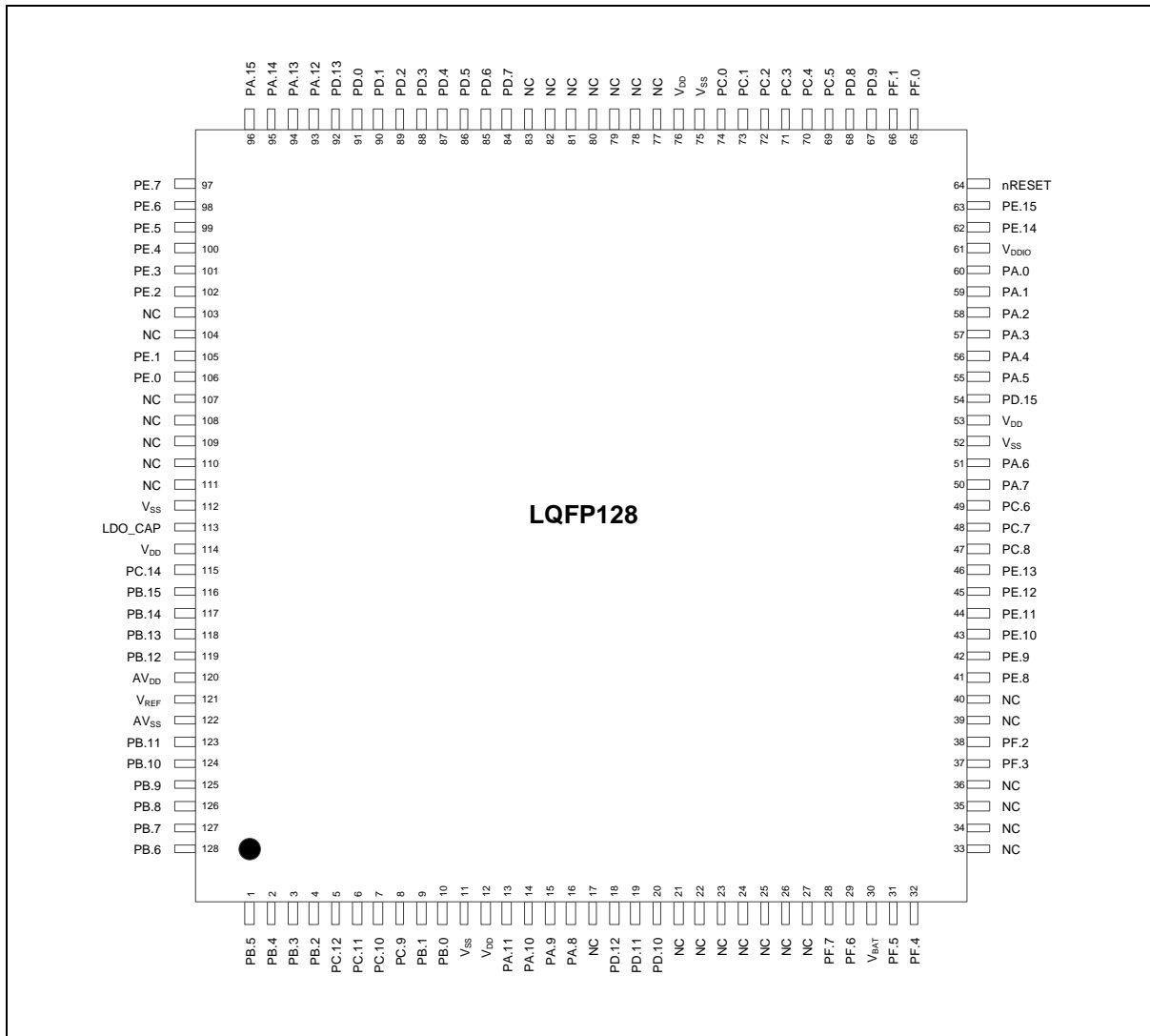

Figure 4.1-7 M251 Series LQFP 128-pin Diagram

4.1.2 M251 Series Multi-function Pin Diagram

4.1.2.1 M251 Series TSSOP 20-Pin Multi-function Pin Diagram

Corresponding Part Number: M251FC2AE

M251FC2AE

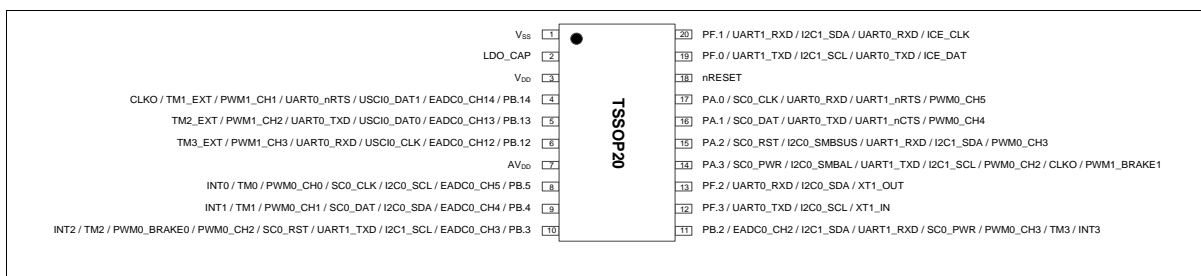

Figure 4.1-8 M251FC2AE Multi-function Pin Diagram

Pin	M251FC2AE Pin Function
1	V <sub>SS</sub>
2	LDO_CAP
3	V <sub>DD</sub>
4	PB.14/EADC0_CH14/USCIO_DAT1/UART0_nRTS/PWM1_CH1/TM1_EXT/CLKO
5	PB.13/EADC0_CH13/USCIO_DAT0/UART0_TXD/PWM1_CH2/TM2_EXT
6	PB.12/EADC0_CH12/USCIO_CLK/UART0_RXD/PWM1_CH3/TM3_EXT
7	AV <sub>DD</sub>
8	PB.5/EADC0_CH5/I2C0_SCL/SC0_CLK/PWM0_CH0/TM0/INT0
9	PB.4/EADC0_CH4/I2C0_SDA/SC0_DAT/PWM0_CH1/TM1/INT1
10	PB.3/EADC0_CH3/I2C1_SCL/UART1_TXD/SC0_RST/PWM0_CH2/PWM0_BRAKE0/TM2/INT2
11	PB.2/EADC0_CH2/I2C1_SDA/UART1_RXD/SC0_PWR/PWM0_CH3/TM3/INT3
12	PF.3/UART0_TXD/I2C0_SCL/XT1_IN
13	PF.2/UART0_RXD/I2C0_SDA/QSPI0_CLK/XT1_OUT
14	PA.3/QSPI0_SS/SC0_PWR/I2C0_SMBAL/UART1_TXD/I2C1_SCL/PWM0_CH2/CLKO/PWM1_BRAKE1
15	PA.2/QSPI0_CLK/SC0_RST/I2C0_SMBSUS/UART1_RXD/I2C1_SDA/PWM0_CH3
16	PA.1/QSPI0_MISO0/SC0_DAT/UART0_TXD/UART1_nCTS/PWM0_CH4
17	PA.0/QSPI0_MOSI0/SC0_CLK/UART0_RXD/UART1_nRTS/PWM0_CH5
18	nRESET <b>Note:</b> It is recommended to use 10 kΩ pull-up resistor and 10 uF capacitor on nRESET pin.
19	PF.0/UART1_TXD/I2C1_SCL/UART0_TXD/ICE_DAT <b>Note:</b> It is recommended to use 100 kΩ pull-up resistor on ICE_DAT pin.
20	PF.1/UART1_RXD/I2C1_SDA/UART0_RXD/ICE_CLK <b>Note:</b> It is recommended to use 100 kΩ pull-up resistor on ICE_CLK pin.

Table 4.1-1 M251FC2AE Multi-function Pin Table

4.1.2.2 M251 Series TSSOP 28-Pin Multi-function Pin Diagram

Corresponding Part Number: M251EC2AE

**M251EC2AE**

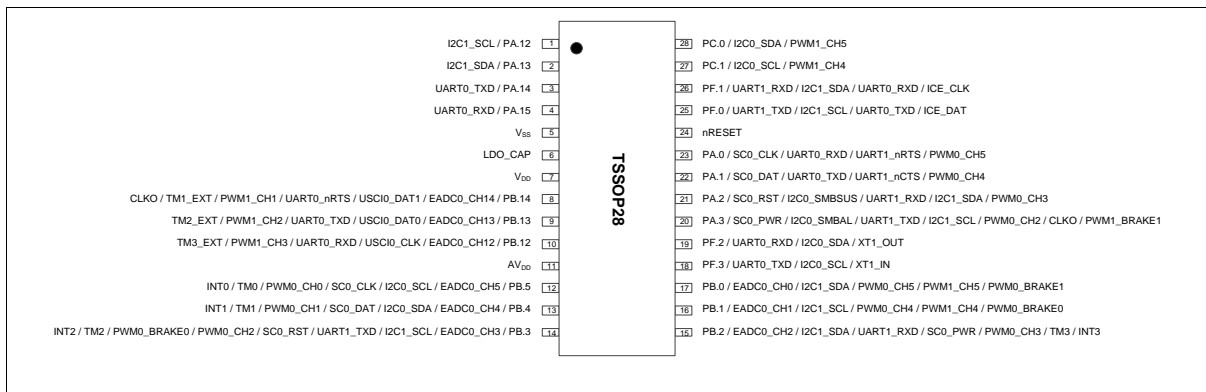

Figure 4.1-9 M251EC2AE Multi-function Pin Diagram

Pin	M251EC2AE Pin Function
1	PA.12/I2C1_SCL
2	PA.13/I2C1_SDA
3	PA.14/UART0_TXD
4	PA.15/UART0_RXD
5	V <sub>SS</sub>
6	LDO_CAP
7	V <sub>DD</sub>
8	PB.14/EADC0_CH14/USCI0_DAT1/UART0_nRTS/PWM1_CH1/TM1_EXT/CLKO
9	PB.13/EADC0_CH13/USCI0_DAT0/UART0_TXD/PWM1_CH2/TM2_EXT
10	PB.12/EADC0_CH12/USCI0_CLK/UART0_RXD/PWM1_CH3/TM3_EXT
11	AV <sub>DD</sub>
12	PB.5/EADC0_CH5/I2C0_SCL/SC0_CLK/PWM0_CH0/TM0/INT0
13	PB.4/EADC0_CH4/I2C0_SDA/SC0_DAT/PWM0_CH1/TM1/INT1
14	PB.3/EADC0_CH3/I2C1_SCL/UART1_TXD/SC0_RST/PWM0_CH2/PWM0_BRAKE0/TM2/INT2
15	PB.2/EADC0_CH2/I2C1_SDA/UART1_RXD/SC0_PWR/PWM0_CH3/TM3/INT3
16	PB.1/EADC0_CH1/I2C1_SCL/QSPI0_MISO1/PWM0_CH4/PWM1_CH4/PWM0_BRAKE0
17	PB.0/EADC0_CH0/I2C1_SDA/QSPI0_MOSI1/PWM0_CH5/PWM1_CH5/PWM0_BRAKE1
18	PF.3/UART0_TXD/I2C0_SCL/XT1_IN
19	PF.2/UART0_RXD/I2C0_SDA/QSPI0_CLK/XT1_OUT
20	PA.3/QSPI0_SS/SC0_PWR/I2C0_SMBAL/UART1_TXD/I2C1_SCL/PWM0_CH2/CLKO/PWM1_BRAKE1
21	PA.2/QSPI0_CLK/SC0_RST/I2C0_SMBSUS/UART1_RXD/I2C1_SDA/PWM0_CH3

22	PA.1/QSPI0_MISO0/SC0_DAT/UART0_TXD/UART1_nCTS/PWM0_CH4
23	PA.0/QSPI0_MOSI0/SC0_CLK/UART0_RXD/UART1_nRTS/PWM0_CH5
24	nRESET <b>Note:</b> It is recommended to use 10 kΩ pull-up resistor and 10 uF capacitor on nRESET pin.
25	PF.0/UART1_TXD/I2C1_SCL/UART0_TXD/ICE_DAT <b>Note:</b> It is recommended to use 100 kΩ pull-up resistor on ICE_DAT pin.
26	PF.1/UART1_RXD/I2C1_SDA/UART0_RXD/ICE_CLK <b>Note:</b> It is recommended to use 100 kΩ pull-up resistor on ICE_CLK pin.
27	PC.1/QSPI0_MISO0/I2C0_SCL/PWM1_CH4
28	PC.0/QSPI0_MOSI0/I2C0_SDA/PWM1_CH5

Table 4.1-2 M251EC2AE Multi-function Pin Table

4.1.2.3 M251 Series QFN 33-Pin Multi-function Pin Diagram

Corresponding Part Number: M251ZC2AE

**M251ZC2AE**

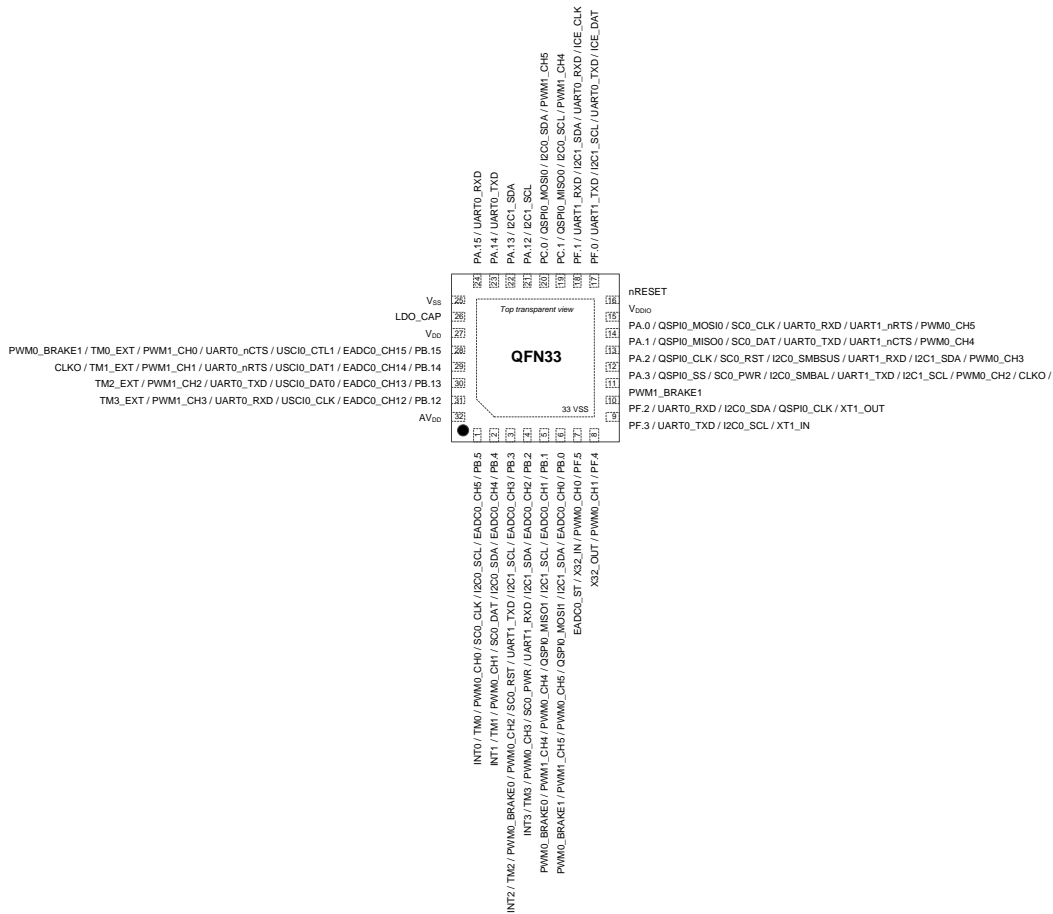

Figure 4.1-10 M251ZC2AE Multi-function Pin Diagram

Pin	M251ZC2AE Pin Function
1	PB.5/EADC0_CH5/I2C0_SCL/SC0_CLK/PWM0_CH0/TM0/INT0
2	PB.4/EADC0_CH4/I2C0_SDA/SC0_DAT/PWM0_CH1/TM1/INT1
3	PB.3/EADC0_CH3/I2C1_SCL/UART1_TXD/SC0_RST/PWM0_CH2/PWM0_BRAKE0/TM2/INT2
4	PB.2/EADC0_CH2/I2C1_SDA/UART1_RXD/SC0_PWR/PWM0_CH3/TM3/INT3

5	PB.1/EADC0_CH1/I2C1_SCL/QSPI0_MISO1/PWM0_CH4/PWM1_CH4/PWM0_BRAKE0
6	PB.0/EADC0_CH0/I2C1_SDA/QSPI0_MOSI1/PWM0_CH5/PWM1_CH5/PWM0_BRAKE1
7	PF.5/PWM0_CH0/X32_IN/EADC0_ST
8	PF.4/PWM0_CH1/X32_OUT
9	PF.3/UART0_TXD/I2C0_SCL/XT1_IN
10	PF.2/UART0_RXD/I2C0_SDA/QSPI0_CLK/XT1_OUT
11	PA.3/QSPI0_SS/SC0_PWR/I2C0_SMBAL/UART1_TXD/I2C1_SCL/PWM0_CH2/CLKO/PWM1_BRAKE1
12	PA.2/QSPI0_CLK/SC0_RST/I2C0_SMBSUS/UART1_RXD/I2C1_SDA/PWM0_CH3
13	PA.1/QSPI0_MISO0/SC0_DAT/UART0_TXD/UART1_nCTS/PWM0_CH4
14	PA.0/QSPI0_MOSI0/SC0_CLK/UART0_RXD/UART1_nRTS/PWM0_CH5
15	V <sub>DDIO</sub>
16	nRESET <b>Note:</b> It is recommended to use 10 kΩ pull-up resistor and 10 uF capacitor on nRESET pin.
17	PF.0/UART1_TXD/I2C1_SCL/UART0_TXD/ICE_DAT <b>Note:</b> It is recommended to use 100 kΩ pull-up resistor on ICE_DAT pin.
18	PF.1/UART1_RXD/I2C1_SDA/UART0_RXD/ICE_CLK <b>Note:</b> It is recommended to use 100 kΩ pull-up resistor on ICE_CLK pin.
19	PC.1/QSPI0_MISO0/I2C0_SCL/PWM1_CH4
20	PC.0/QSPI0_MOSI0/I2C0_SDA/PWM1_CH5
21	PA.12/I2C1_SCL
22	PA.13/I2C1_SDA
23	PA.14/UART0_TXD
24	PA.15/UART0_RXD
25	V <sub>SS</sub>
26	LDO_CAP
27	V <sub>DD</sub>
28	PB.15/EADC0_CH15/USCI0_CTL1/UART0_nCTS/PWM1_CH0/TM0_EXT/PWM0_BRAKE1
29	PB.14/EADC0_CH14/USCI0_DAT1/UART0_nRTS/PWM1_CH1/TM1_EXT/CLKO
30	PB.13/EADC0_CH13/USCI0_DAT0/UART0_TXD/PWM1_CH2/TM2_EXT
31	PB.12/EADC0_CH12/USCI0_CLK/UART0_RXD/PWM1_CH3/TM3_EXT
32	AV <sub>DD</sub>

Table 4.1-3 M251ZC2AE Multi-function Pin Table

Corresponding Part Number: M251ZD2AE

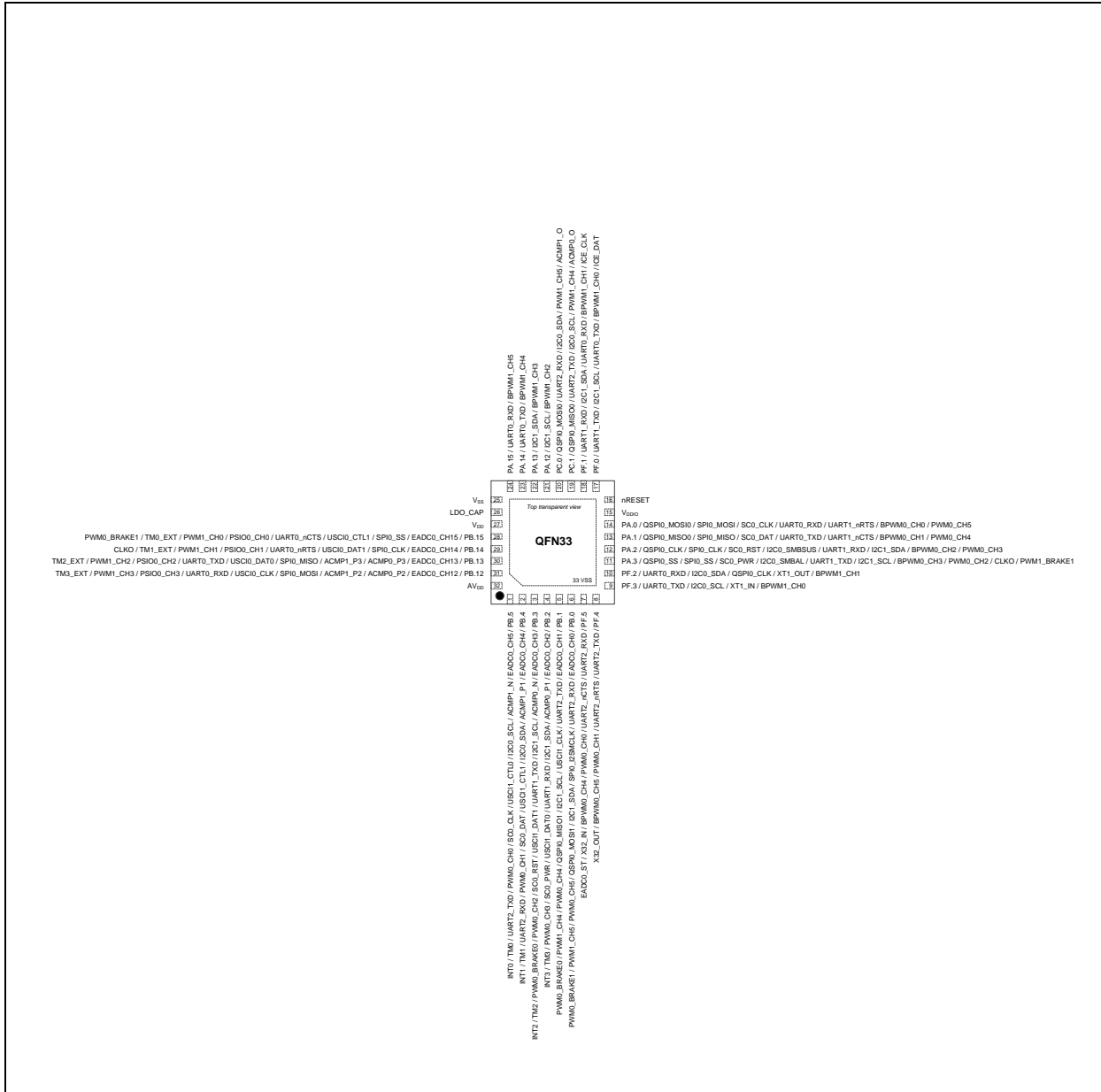

Figure 4.1-11 M251ZD2AE Function Pin Diagram

Pin	M251ZD2AE Pin Function
1	PB.5/EADC0_CH5/ACMP1_N/I2C0_SCL/USCI1_CTL0/SC0_CLK/PWM0_CH0/UART2_TXD/TM0/INT0
2	PB.4/EADC0_CH4/ACMP1_P1/I2C0_SDA/USCI1_CTL1/SC0_DAT/PWM0_CH1/UART2_RXD/TM1/INT1
3	PB.3/EADC0_CH3/ACMP0_N/I2C1_SCL/UART1_TXD/USCI1_DAT1/SC0_RST/PWM0_CH2/PWM0_BRAKE0/TM2/INT2
4	PB.2/EADC0_CH2/ACMP0_P1/I2C1_SDA/UART1_RXD/USCI1_DAT0/SC0_PWR/PWM0_CH3/TM3/INT3
5	PB.1/EADC0_CH1/UART2_TXD/USCI1_CLK/I2C1_SCL/QSPI0_MISO1/PWM0_CH4/PWM1_CH4/PWM0_BRAKE0
6	PB.0/EADC0_CH0/UART2_RXD/SPI0_I2SMCLK/I2C1_SDA/QSPI0_MOSI1/PWM0_CH5/PWM1_CH5/PWM0_BRAKE1

7	PF.5/UART2_RXD/UART2_nCTS/PWM0_CH0/BPWM0_CH4/X32_IN/EADC0_ST
8	PF.4/UART2_TXD/UART2_nRTS/PWM0_CH1/BPWM0_CH5/X32_OUT
9	PF.3/UART0_TXD/I2C0_SCL/XT1_IN/BPWM1_CH0
10	PF.2/UART0_RXD/I2C0_SDA/QSPI0_CLK/XT1_OUT/BPWM1_CH1
11	PA.3/QSPI0_SS/SPI0_SS/SC0_PWR/I2C0_SMBAL/UART1_TXD/I2C1_SCL/BPWM0_CH3/PWM0_CH2/CLKO/PWM1_BRAKE1
12	PA.2/QSPI0_CLK/SPI0_CLK/SC0_RST/I2C0_SMBUS/UART1_RXD/I2C1_SDA/BPWM0_CH2/PWM0_CH3
13	PA.1/QSPI0_MISO0/SPI0_MISO/SC0_DAT/UART0_TXD/UART1_nCTS/BPWM0_CH1/PWM0_CH4
14	PA.0/QSPI0_MOSI0/SPI0_MOSI/SC0_CLK/UART0_RXD/UART1_nRTS/BPWM0_CH0/PWM0_CH5
15	V <sub>DDIO</sub>
16	nRESET <b>Note:</b> It is recommended to use 10 kΩ pull-up resistor and 10 uF capacitor on nRESET pin.
17	PF.0/UART1_TXD/I2C1_SCL/UART0_TXD/BPWM1_CH0/ICE_DAT <b>Note:</b> It is recommended to use 100 kΩ pull-up resistor on ICE_DAT pin.
18	PF.1/UART1_RXD/I2C1_SDA/UART0_RXD/BPWM1_CH1/ICE_CLK <b>Note:</b> It is recommended to use 100 kΩ pull-up resistor on ICE_CLK pin.
19	PC.1/QSPI0_MISO0/UART2_TXD/I2C0_SCL/PWM1_CH4/ACMP0_O
20	PC.0/QSPI0_MOSI0/UART2_RXD/I2C0_SDA/PWM1_CH5/ACMP1_O
21	PA.12/I2C1_SCL/BPWM1_CH2
22	PA.13/I2C1_SDA/BPWM1_CH3
23	PA.14/UART0_TXD/BPWM1_CH4
24	PA.15/UART0_RXD/BPWM1_CH5
25	V <sub>SS</sub>
26	LDO_CAP
27	V <sub>DD</sub>
28	PB.15/EADC0_CH15/SPI0_SS/USCI0_CTL1/UART0_nCTS/PSIO0_CH0/PWM1_CH0/TM0_EXT/PWM0_BRAKE1
29	PB.14/EADC0_CH14/SPI0_CLK/USCI0_DAT1/UART0_nRTS/PSIO0_CH1/PWM1_CH1/TM1_EXT/CLKO
30	PB.13/EADC0_CH13/ACMP0_P3/ACMP1_P3/SPI0_MISO/USCI0_DAT0/UART0_TXD/PSIO0_CH2/PWM1_CH2/TM2_EXT
31	PB.12/EADC0_CH12/ACMP0_P2/ACMP1_P2/SPI0_MOSI/USCI0_CLK/UART0_RXD/PSIO0_CH3/PWM1_CH3/TM3_EXT
32	AV <sub>DD</sub>

Table 4.1-4 M251ZD2AE Multi-function Pin Table

4.1.2.4 M251 Series LQFP 48-Pin Multi-function Pin Diagram

Corresponding Part Number: M251LC2AE, M251LD2AE, M251LE3AE, M251LG6AE

M251LC2AE / M251LD2AE

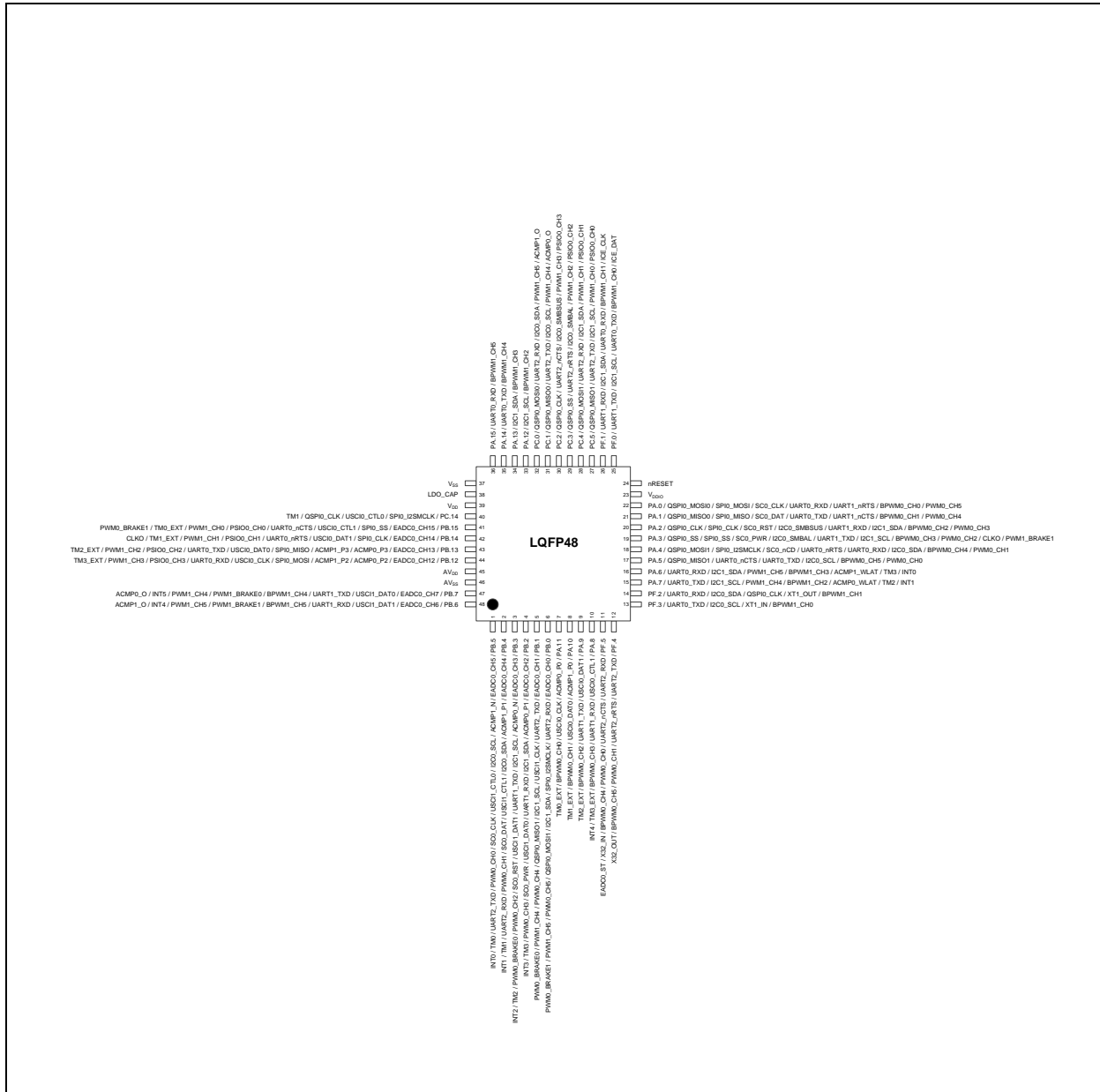

Figure 4.1-12 M251LC2AE/M251LD2AE Multi-function Pin Diagram

Pin	M251LC2AE/M251LD2AE Pin Function
1	PB.5/EADC0_CH5/ACMP1_N/I2C0_SCL/USC11_CTL0/SC0_CLK/PWM0_CH0/UART2_TXD/TM0/INT0
2	PB.4/EADC0_CH4/ACMP1_P1/I2C0_SDA/USC11_CTL1/SC0_DAT/PWM0_CH1/UART2_RXD/TM1/INT1
3	PB.3/EADC0_CH3/ACMP0_N/I2C1_SCL/UART1_TXD/USC11_DAT1/SC0_RST/PWM0_CH2/PWM0_BRAKE0/TM2/INT2
4	PB.2/EADC0_CH2/ACMP0_P1/I2C1_SDA/UART1_RXD/USC11_DAT0/SC0_PWR/PWM0_CH3/TM3/INT3

5	PB.1/EADC0_CH1/UART2_TXD/USCI1_CLK/I2C1_SCL/QSPI0_MISO1/PWM0_CH4/PWM1_CH4/PWM0_BRAKE0
6	PB.0/EADC0_CH0/UART2_RXD/SPI0_I2SMCLK/I2C1_SDA/QSPI0_MOSI1/PWM0_CH5/PWM1_CH5/PWM0_BRAKE1
7	PA.11/ACMP0_P0/USCI0_CLK/BPWM0_CH0/TM0_EXT
8	PA.10/ACMP1_P0/USCI0_DAT0/BPWM0_CH1/TM1_EXT
9	PA.9/USCI0_DAT1/UART1_TXD/BPWM0_CH2/TM2_EXT
10	PA.8/USCI0_CTL1/UART1_RXD/BPWM0_CH3/TM3_EXT/INT4
11	PF.5/UART2_RXD/UART2_nCTS/PWM0_CH0/BPWM0_CH4/X32_IN/EADC0_ST
12	PF.4/UART2_TXD/UART2_nRTS/PWM0_CH1/BPWM0_CH5/X32_OUT
13	PF.3/UART0_TXD/I2C0_SCL/XT1_IN/BPWM1_CH0
14	PF.2/UART0_RXD/I2C0_SDA/QSPI0_CLK/XT1_OUT/BPWM1_CH1
15	PA.7/UART0_TXD/I2C1_SCL/PWM1_CH4/BPWM1_CH2/ACMP0_WLAT/TM2/INT1
16	PA.6/UART0_RXD/I2C1_SDA/PWM1_CH5/BPWM1_CH3/ACMP1_WLAT/TM3/INT0
17	PA.5/QSPI0_MISO1/UART0_nCTS/UART0_TXD/I2C0_SCL/BPWM0_CH5/PWM0_CH0
18	PA.4/QSPI0_MOSI1/SPI0_I2SMCLK/SC0_nCD/UART0_nRTS/UART0_RXD/I2C0_SDA/BPWM0_CH4/PWM0_CH1
19	PA.3/QSPI0_SS/SPI0_SS/SC0_PWR/I2C0_SMBAL/UART1_TXD/I2C1_SCL/BPWM0_CH3/PWM0_CH2/CLKO/PWM1_BRAKE1
20	PA.2/QSPI0_CLK/SPI0_CLK/SC0_RST/I2C0_SMBSUS/UART1_RXD/I2C1_SDA/BPWM0_CH2/PWM0_CH3
21	PA.1/QSPI0_MISO0/SPI0_MISO/SC0_DAT/UART0_TXD/UART1_nCTS/BPWM0_CH1/PWM0_CH4
22	PA.0/QSPI0_MOSI0/SPI0_MOSI/SC0_CLK/UART0_RXD/UART1_nRTS/BPWM0_CH0/PWM0_CH5
23	V <sub>DDIO</sub>
24	nRESET <b>Note:</b> It is recommended to use 10 kΩ pull-up resistor and 10 uF capacitor on nRESET pin.
25	PF.0/UART1_TXD/I2C1_SCL/UART0_TXD/BPWM1_CH0/ICE_DAT <b>Note:</b> It is recommended to use 100 kΩ pull-up resistor on ICE_DAT pin.
26	PF.1/UART1_RXD/I2C1_SDA/UART0_RXD/BPWM1_CH1/ICE_CLK <b>Note:</b> It is recommended to use 100 kΩ pull-up resistor on ICE_CLK pin.
27	PC.5/QSPI0_MISO1/UART2_TXD/I2C1_SCL/PWM1_CH0/PSIO0_CH0
28	PC.4/QSPI0_MOSI1/UART2_RXD/I2C1_SDA/PWM1_CH1/PSIO0_CH1
29	PC.3/QSPI0_SS/UART2_nRTS/I2C0_SMBAL/PWM1_CH2/PSIO0_CH2
30	PC.2/QSPI0_CLK/UART2_nCTS/I2C0_SMBSUS/PWM1_CH3/PSIO0_CH3
31	PC.1/QSPI0_MISO0/UART2_TXD/I2C0_SCL/PWM1_CH4/ACMP0_O
32	PC.0/QSPI0_MOSI0/UART2_RXD/I2C0_SDA/PWM1_CH5/ACMP1_O
33	PA.12/I2C1_SCL/BPWM1_CH2
34	PA.13/I2C1_SDA/BPWM1_CH3
35	PA.14/UART0_TXD/BPWM1_CH4
36	PA.15/UART0_RXD/BPWM1_CH5

37	V <sub>SS</sub>
38	LDO_CAP
39	V <sub>DD</sub>
40	PC.14/SPI0_I2SMCLK/USCI0_CTL0/QSPI0_CLK/TM1
41	PB.15/EADC0_CH15/SPI0_SS/USCI0_CTL1/UART0_nCTS/PSIO0_CH0/PWM1_CH0/TM0_EXT/PWM0_BRAKE1
42	PB.14/EADC0_CH14/SPI0_CLK/USCI0_DAT1/UART0_nRTS/PSIO0_CH1/PWM1_CH1/TM1_EXT/CLKO
43	PB.13/EADC0_CH13/ACMP0_P3/ACMP1_P3/SPI0_MISO/USCI0_DAT0/UART0_TXD/PSIO0_CH2/PWM1_CH2/TM2_EXT
44	PB.12/EADC0_CH12/ACMP0_P2/ACMP1_P2/SPI0_MOSI/USCI0_CLK/UART0_RXD/PSIO0_CH3/PWM1_CH3/TM3_EXT
45	AV <sub>DD</sub>
46	AV <sub>SS</sub>
47	PB.7/EADC0_CH7/USCI1_DAT0/UART1_TXD/BPWM1_CH4/PWM1_BRAKE0/PWM1_CH4/INT5/ACMP0_O
48	PB.6/EADC0_CH6/USCI1_DAT1/UART1_RXD/BPWM1_CH5/PWM1_BRAKE1/PWM1_CH5/INT4/ACMP1_O

Table 4.1-5 M251LC2AE/M251LD2AE Multi-function Pin Table

M251LE3AE

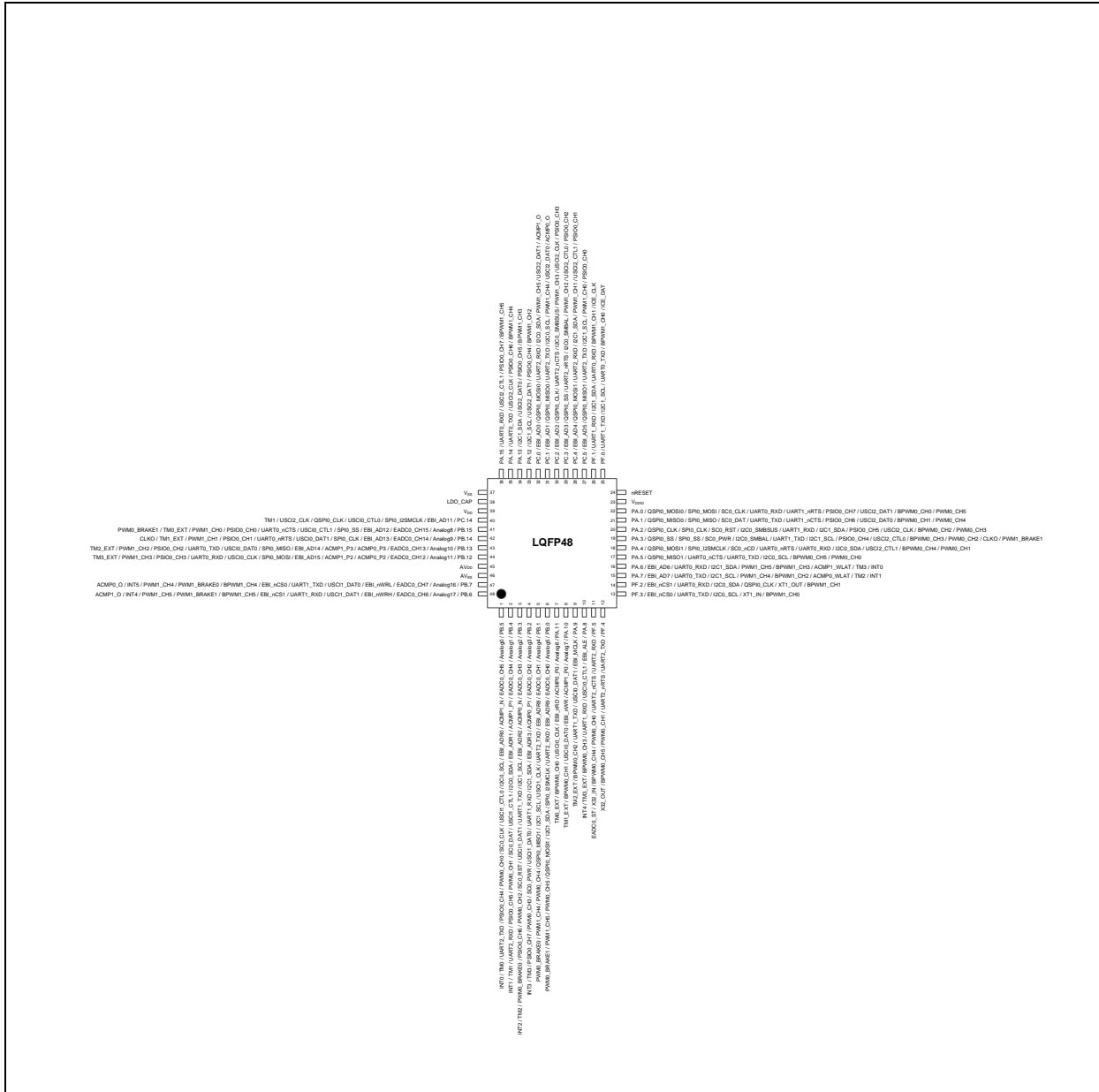

Figure 4.1-13 M251LE3AE Multi-function Pin Diagram

Pin	M251LE3AE Pin Function
1	PB.5/EADC0_CH5/ACMP1_N/EBI_ADR0/I2C0_SCL/USC11_CTL0/SC0_CLK/PWM0_CH0/PSIO0_CH4/UART2_TXD/TM0/INT0
2	PB.4/EADC0_CH4/ACMP1_P1/EBI_ADR1/I2C0_SDA/USC11_CTL1/SC0_DAT/PWM0_CH1/PSIO0_CH5/UART2_RXD/TM1/INT1
3	PB.3/EADC0_CH3/ACMP0_N/EBI_ADR2/I2C1_SCL/UART1_TXD/USC11_DAT1/SC0_RST/PWM0_CH2/PSIO0_CH6/PWM0_BRAKE0/TM2/INT2
4	PB.2/EADC0_CH2/ACMP0_P1/EBI_ADR3/I2C1_SDA/UART1_RXD/USC11_DAT0/SC0_PWR/PWM0_CH3/PSIO0_CH7/TM3/INT3

5	PB.1/EADC0_CH1/EBI_ADR8/UART2_TXD/USCI1_CLK/I2C1_SCL/QSPI0_MISO1/PWM0_CH4/PWM1_CH4/PWM0_BRAKE0
6	PB.0/EADC0_CH0/EBI_ADR9/UART2_RXD/SPI0_I2SMCLK/I2C1_SDA/QSPI0_MOSI1/PWM0_CH5/PWM1_CH5/PWM0_BRAKE1
7	PA.11/ACMP0_P0/EBI_nRD/USCI0_CLK/BPWM0_CH0/TM0_EXT
8	PA.10/ACMP1_P0/EBI_nWR/USCI0_DAT0/BPWM0_CH1/TM1_EXT
9	PA.9/EBI_MCLK/USCI0_DAT1/UART1_TXD/BPWM0_CH2/TM2_EXT
10	PA.8/EBI_ALE/USCI0_CTL1/UART1_RXD/BPWM0_CH3/TM3_EXT/INT4
11	PF.5/UART2_RXD/UART2_nCTS/PWM0_CH0/BPWM0_CH4/X32_IN/EADC0_ST
12	PF.4/UART2_TXD/UART2_nRTS/PWM0_CH1/BPWM0_CH5/X32_OUT
13	PF.3/EBI_nCS0/UART0_TXD/I2C0_SCL/XT1_IN/BPWM1_CH0
14	PF.2/EBI_nCS1/UART0_RXD/I2C0_SDA/QSPI0_CLK/XT1_OUT/BPWM1_CH1
15	PA.7/EBI_AD7/UART0_TXD/I2C1_SCL/PWM1_CH4/BPWM1_CH2/ACMP0_WLAT/TM2/INT1
16	PA.6/EBI_AD6/UART0_RXD/I2C1_SDA/PWM1_CH5/BPWM1_CH3/ACMP1_WLAT/TM3/INT0
17	PA.5/QSPI0_MISO1/UART0_nCTS/UART0_TXD/I2C0_SCL/BPWM0_CH5/PWM0_CH0
18	PA.4/QSPI0_MOSI1/SPI0_I2SMCLK/SC0_nCD/UART0_nRTS/UART0_RXD/I2C0_SDA/USCI2_CTL1/BPWM0_CH4/PWM0_CH1
19	PA.3/QSPI0_SS/SPI0_SS/SC0_PWR/I2C0_SMBAL/UART1_TXD/I2C1_SCL/PSIO0_CH4/USCI2_CTL0/BPWM0_CH3/PWM0_CH2/CLKO/PWM1_BRAKE1
20	PA.2/QSPI0_CLK/SPI0_CLK/SC0_RST/I2C0_SMBUS/UART1_RXD/I2C1_SDA/PSIO0_CH5/USCI2_CLK/BPWM0_CH2/PWM0_CH3
21	PA.1/QSPI0_MISO0/SPI0_MISO/SC0_DAT/UART0_TXD/UART1_nCTS/PSIO0_CH6/USCI2_DAT0/BPWM0_CH1/PWM0_CH4
22	PA.0/QSPI0_MOSI0/SPI0_MOSI/SC0_CLK/UART0_RXD/UART1_nRTS/PSIO0_CH7/USCI2_DAT1/BPWM0_CH0/PWM0_CH5
23	V <sub>DDIO</sub>
24	nRESET <b>Note:</b> It is recommended to use 10 kΩ pull-up resistor and 10 uF capacitor on nRESET pin.
25	PF.0/UART1_TXD/I2C1_SCL/UART0_TXD/BPWM1_CH0/ICE_DAT <b>Note:</b> It is recommended to use 100 kΩ pull-up resistor on ICE_DAT pin.
26	PF.1/UART1_RXD/I2C1_SDA/UART0_RXD/BPWM1_CH1/ICE_CLK <b>Note:</b> It is recommended to use 100 kΩ pull-up resistor on ICE_CLK pin.
27	PC.5/EBI_AD5/QSPI0_MISO1/UART2_TXD/I2C1_SCL/PWM1_CH0/PSIO0_CH0
28	PC.4/EBI_AD4/QSPI0_MOSI1/UART2_RXD/I2C1_SDA/PWM1_CH1/USCI2_CTL1/PSIO0_CH1
29	PC.3/EBI_AD3/QSPI0_SS/UART2_nRTS/I2C0_SMBAL/PWM1_CH2/USCI2_CTL0/PSIO0_CH2
30	PC.2/EBI_AD2/QSPI0_CLK/UART2_nCTS/I2C0_SMBUS/PWM1_CH3/USCI2_CLK/PSIO0_CH3
31	PC.1/EBI_AD1/QSPI0_MISO0/UART2_TXD/I2C0_SCL/PWM1_CH4/USCI2_DAT0/ACMP0_O
32	PC.0/EBI_AD0/QSPI0_MOSI0/UART2_RXD/I2C0_SDA/PWM1_CH5/USCI2_DAT1/ACMP1_O
33	PA.12/I2C1_SCL/USCI2_DAT1/PSIO0_CH4/BPWM1_CH2
34	PA.13/I2C1_SDA/USCI2_DAT0/PSIO0_CH5/BPWM1_CH3

35	PA.14/UART0_TXD/USCI2_CLK/PSIO0_CH6/BPWM1_CH4
36	PA.15/UART0_RXD/USCI2_CTL1/PSIO0_CH7/BPWM1_CH5
37	V <sub>SS</sub>
38	LDO_CAP
39	V <sub>DD</sub>
40	PC.14/EBI_AD11/SPI0_I2SMCLK/USCI0_CTL0/QSPI0_CLK/USCI2_CLK/TM1
41	PB.15/EADC0_CH15/EBI_AD12/SPI0_SS/USCI0_CTL1/UART0_nCTS/PSIO0_CH0/PWM1_CH0/TM0_EXT/PWM0_BRAKE1
42	PB.14/EADC0_CH14/EBI_AD13/SPI0_CLK/USCI0_DAT1/UART0_nRTS/PSIO0_CH1/PWM1_CH1/TM1_EXT/CLKO
43	PB.13/EADC0_CH13/ACMP0_P3/ACMP1_P3/EBI_AD14/SPI0_MISO/USCI0_DAT0/UART0_TXD/PSIO0_CH2/PWM1_CH2/TM2_EXT
44	PB.12/EADC0_CH12/ACMP0_P2/ACMP1_P2/EBI_AD15/SPI0_MOSI/USCI0_CLK/UART0_RXD/PSIO0_CH3/PWM1_CH3/TM3_EXT
45	AV <sub>DD</sub>
46	AV <sub>SS</sub>
47	PB.7/EADC0_CH7/EBI_nWRL/USCI1_DAT0/UART1_TXD/EBI_nCS0/BPWM1_CH4/PWM1_BRAKE0/PWM1_CH4/INT5/ACMP0_O
48	PB.6/EADC0_CH6/EBI_nWRH/USCI1_DAT1/UART1_RXD/EBI_nCS1/BPWM1_CH5/PWM1_BRAKE1/PWM1_CH5/INT4/ACMP1_O

Table 4.1-6 M251LE3AE Multi-function Pin Table

M251LG6AE

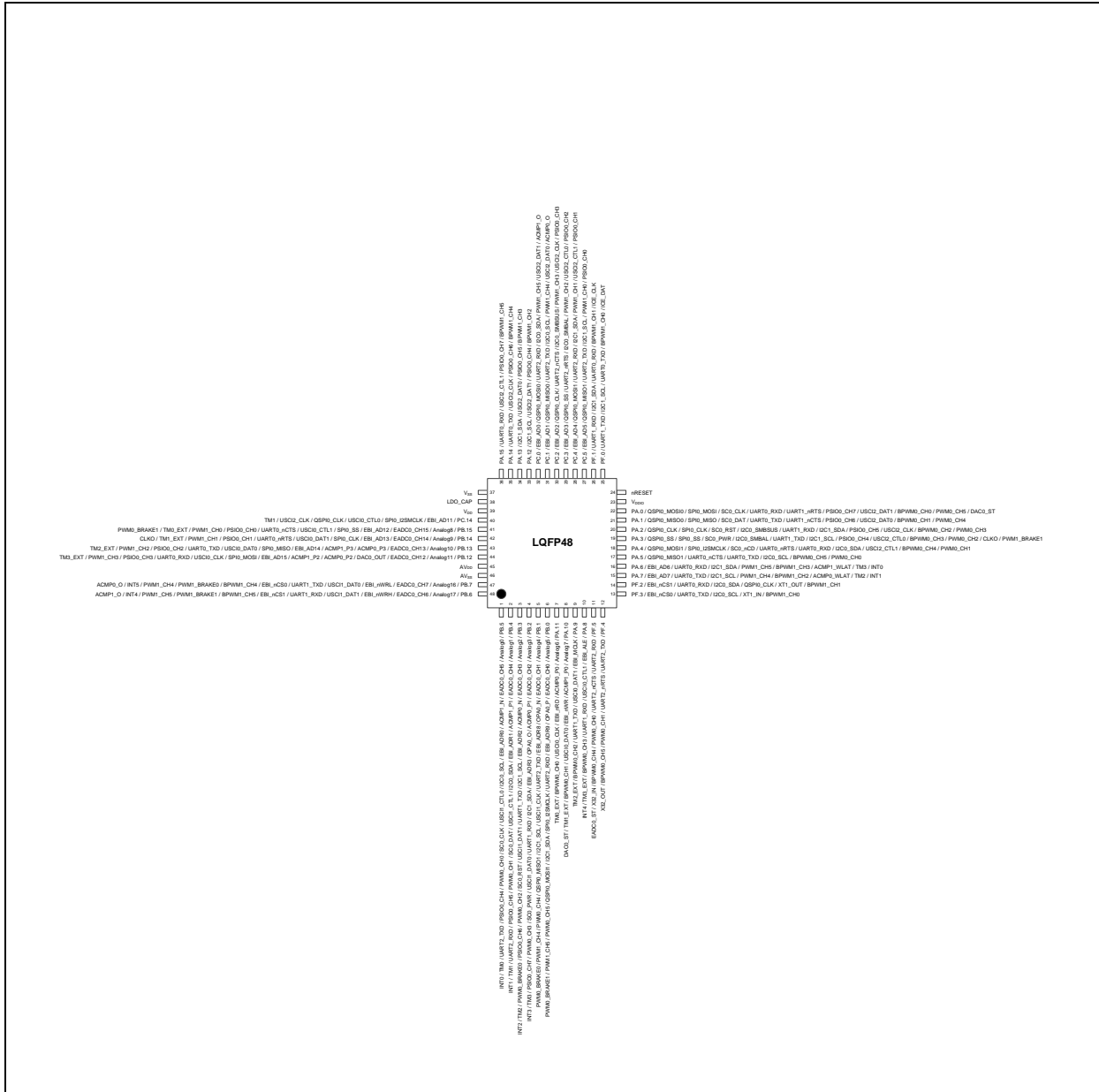

Figure 4.1-14 M251LG6AE Multi-function Pin Diagram

Pin	M251LG6AE Pin Function
1	PB.5/EADC0_CH5/ACMP1_N/EBI_ADR0/I2C0_SCL/USC11_CTL0/SC0_CLK/PWM0_CH0/PSIO0_CH4/UART2_TXD/TM0/INT0
2	PB.4/EADC0_CH4/ACMP1_P1/EBI_ADR1/I2C0_SDA/USC11_CTL1/SC0_DAT/PWM0_CH1/PSIO0_CH5/UART2_RXD/TM1/INT1
3	PB.3/EADC0_CH3/ACMP0_N/EBI_ADR2/I2C1_SCL/UART1_TXD/USC11_DAT1/SC0_RST/PWM0_CH2/PSIO0_CH6/PWM0_BRAKE0/TM2/INT2
4	PB.2/EADC0_CH2/ACMP0_P1/OPA0_O/EBI_ADR3/I2C1_SDA/UART1_RXD/USC11_DAT0/SC0_PWR/PWM0_CH3/PSIO0_CH7/TM3/INT3

5	PB.1/EADC0_CH1/OPA0_N/EBI_ADR8/UART2_TXD/USCI1_CLK/I2C1_SCL/QSPI0_MISO1/PWM0_CH4/PWM1_CH4/PWM0_BRAKE0
6	PB.0/EADC0_CH0/OPA0_P/EBI_ADR9/UART2_RXD/SPI0_I2SMCLK/I2C1_SDA/QSPI0_MOSI1/PWM0_CH5/PWM1_CH5/PWM0_BRAKE1
7	PA.11/ACMP0_P0/EBI_nRD/USCI0_CLK/BPWM0_CH0/TM0_EXT
8	PA.10/ACMP1_P0/EBI_nWR/USCI0_DAT0/BPWM0_CH1/TM1_EXT/DAC0_ST
9	PA.9/EBI_MCLK/USCI0_DAT1/UART1_TXD/BPWM0_CH2/TM2_EXT
10	PA.8/EBI_ALE/USCI0_CTL1/UART1_RXD/BPWM0_CH3/TM3_EXT/INT4
11	PF.5/UART2_RXD/UART2_nCTS/PWM0_CH0/BPWM0_CH4/X32_IN/EADC0_ST
12	PF.4/UART2_TXD/UART2_nRTS/PWM0_CH1/BPWM0_CH5/X32_OUT
13	PF.3/EBI_nCS0/UART0_TXD/I2C0_SCL/XT1_IN/BPWM1_CH0
14	PF.2/EBI_nCS1/UART0_RXD/I2C0_SDA/QSPI0_CLK/XT1_OUT/BPWM1_CH1
15	PA.7/EBI_AD7/UART0_TXD/I2C1_SCL/PWM1_CH4/BPWM1_CH2/ACMP0_WLAT/TM2/INT1
16	PA.6/EBI_AD6/UART0_RXD/I2C1_SDA/PWM1_CH5/BPWM1_CH3/ACMP1_WLAT/TM3/INT0
17	PA.5/QSPI0_MISO1/UART0_nCTS/UART0_TXD/I2C0_SCL/BPWM0_CH5/PWM0_CH0
18	PA.4/QSPI0_MOSI1/SPI0_I2SMCLK/SC0_nCD/UART0_nRTS/UART0_RXD/I2C0_SDA/USCI2_CTL1/BPWM0_CH4/PWM0_CH1
19	PA.3/QSPI0_SS/SPI0_SS/SC0_PWR/I2C0_SMBAL/UART1_TXD/I2C1_SCL/PSIO0_CH4/USCI2_CTL0/BPWM0_CH3/PWM0_CH2/CLKO/PWM1_BRAKE1
20	PA.2/QSPI0_CLK/SPI0_CLK/SC0_RST/I2C0_SMBUS/UART1_RXD/I2C1_SDA/PSIO0_CH5/USCI2_CLK/BPWM0_CH2/PWM0_CH3
21	PA.1/QSPI0_MISO0/SPI0_MISO/SC0_DAT/UART0_TXD/UART1_nCTS/PSIO0_CH6/USCI2_DAT0/BPWM0_CH1/PWM0_CH4
22	PA.0/QSPI0_MOSI0/SPI0_MOSI/SC0_CLK/UART0_RXD/UART1_nRTS/PSIO0_CH7/USCI2_DAT1/BPWM0_CH0/PWM0_CH5/DAC0_ST
23	V <sub>DDIO</sub>
24	nRESET <b>Note:</b> It is recommended to use 10 kΩ pull-up resistor and 10 uF capacitor on nRESET pin.
25	PF.0/UART1_TXD/I2C1_SCL/UART0_TXD/BPWM1_CH0/ICE_DAT <b>Note:</b> It is recommended to use 100 kΩ pull-up resistor on ICE_DAT pin.
26	PF.1/UART1_RXD/I2C1_SDA/UART0_RXD/BPWM1_CH1/ICE_CLK <b>Note:</b> It is recommended to use 100 kΩ pull-up resistor on ICE_CLK pin.
27	PC.5/EBI_AD5/QSPI0_MISO1/UART2_TXD/I2C1_SCL/PWM1_CH0/PSIO0_CH0
28	PC.4/EBI_AD4/QSPI0_MOSI1/UART2_RXD/I2C1_SDA/PWM1_CH1/USCI2_CTL1/PSIO0_CH1
29	PC.3/EBI_AD3/QSPI0_SS/UART2_nRTS/I2C0_SMBAL/PWM1_CH2/USCI2_CTL0/PSIO0_CH2
30	PC.2/EBI_AD2/QSPI0_CLK/UART2_nCTS/I2C0_SMBUS/PWM1_CH3/USCI2_CLK/PSIO0_CH3
31	PC.1/EBI_AD1/QSPI0_MISO0/UART2_TXD/I2C0_SCL/PWM1_CH4/USCI2_DAT0/ACMP0_O
32	PC.0/EBI_AD0/QSPI0_MOSI0/UART2_RXD/I2C0_SDA/PWM1_CH5/USCI2_DAT1/ACMP1_O
33	PA.12/I2C1_SCL/USCI2_DAT1/PSIO0_CH4/BPWM1_CH2
34	PA.13/I2C1_SDA/USCI2_DAT0/PSIO0_CH5/BPWM1_CH3

35	PA.14/UART0_TXD/USCI2_CLK/PSIO0_CH6/BPWM1_CH4
36	PA.15/UART0_RXD/USCI2_CTL1/PSIO0_CH7/BPWM1_CH5
37	V <sub>SS</sub>
38	LDO_CAP
39	V <sub>DD</sub>
40	PC.14/EBI_AD11/SPI0_I2SMCLK/USCI0_CTL0/QSPI0_CLK/USCI2_CLK/TM1
41	PB.15/EADC0_CH15/EBI_AD12/SPI0_SS/USCI0_CTL1/UART0_nCTS/PSIO0_CH0/PWM1_CH0/TM0_EXT/PWM0_BRAKE1
42	PB.14/EADC0_CH14/EBI_AD13/SPI0_CLK/USCI0_DAT1/UART0_nRTS/PSIO0_CH1/PWM1_CH1/TM1_EXT/CLKO
43	PB.13/EADC0_CH13/ACMP0_P3/ACMP1_P3/EBI_AD14/SPI0_MISO/USCI0_DAT0/UART0_TXD/PSIO0_CH2/PWM1_CH2/TM2_EXT
44	PB.12/EADC0_CH12/DAC0_OUT/ACMP0_P2/ACMP1_P2/EBI_AD15/SPI0_MOSI/USCI0_CLK/UART0_RXD/PSIO0_CH3/PWM1_CH3/TM3_EXT
45	AV <sub>DD</sub>
46	AV <sub>SS</sub>
47	PB.7/EADC0_CH7/EBI_nWRL/USCI1_DAT0/UART1_TXD/EBI_nCS0/BPWM1_CH4/PWM1_BRAKE0/PWM1_CH4/INT5/ACMP0_O
48	PB.6/EADC0_CH6/EBI_nWRH/USCI1_DAT1/UART1_RXD/EBI_nCS1/BPWM1_CH5/PWM1_BRAKE1/PWM1_CH5/INT4/ACMP1_O

Table 4.1-7 M251LG6AE Multi-function Pin Table

4.1.2.5 M251 Series LQFP 64-Pin Multi-function Pin Diagram

Corresponding Part Number: M251SC2AE, M251SD2AE, M251SE3AE, M251SG6AE

M251SC2AE / M251SD2AE

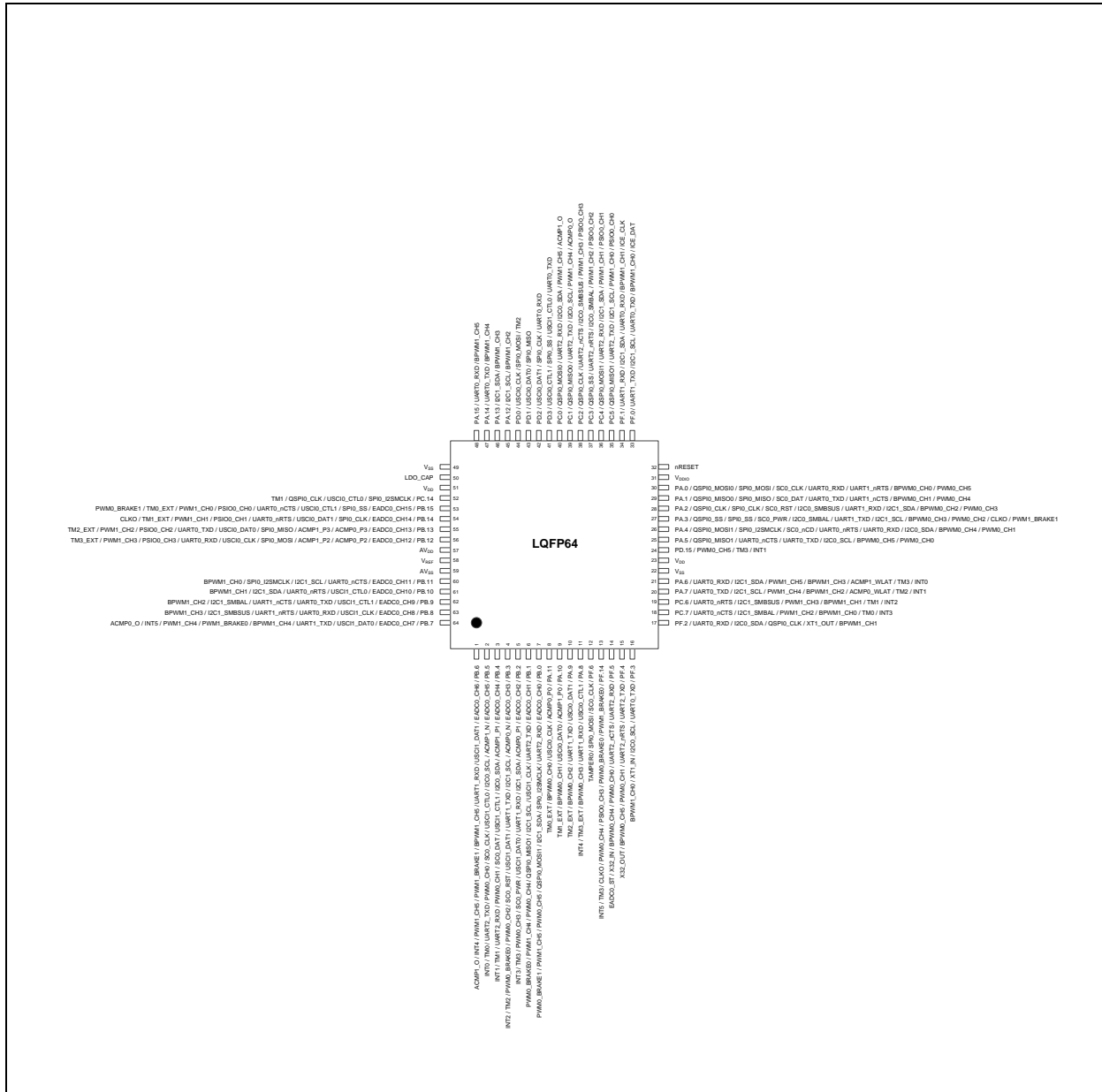

Figure 4.1-15 M251SC2AE/M251SD2AE Multi-function Pin Diagram

Pin	M251SC2AE/M251SD2AE Pin Function
1	PB.6/EADC0_CH6/USCI1_DAT1/UART1_RXD/BPWM1_CH5/PWM1_BRAKE1/PWM1_CH5/INT4/ACMP1_O
2	PB.5/EADC0_CH5/ACMP1_N/I2C0_SCL/USCI1_CTL0/SC0_CLK/PWM0_CH0/UART2_TXD/TM0/INT0
3	PB.4/EADC0_CH4/ACMP1_P1/I2C0_SDA/USCI1_CTL1/SC0_DAT/PWM0_CH1/UART2_RXD/TM1/INT1

4	PB.3/EADC0_CH3/ACMP0_N/I2C1_SCL/UART1_TXD/USCI1_DAT1/SC0_RST/PWM0_CH2/PWM0_BRAKE0/TM2/INT2
5	PB.2/EADC0_CH2/ACMP0_P1/I2C1_SDA/UART1_RXD/USCI1_DAT0/SC0_PWR/PWM0_CH3/TM3/INT3
6	PB.1/EADC0_CH1/UART2_TXD/USCI1_CLK/I2C1_SCL/QSPI0_MISO1/PWM0_CH4/PWM1_CH4/PWM0_BRAKE0
7	PB.0/EADC0_CH0/UART2_RXD/SPI0_I2SMCLK/I2C1_SDA/QSPI0_MOSI1/PWM0_CH5/PWM1_CH5/PWM0_BRAKE1
8	PA.11/ACMP0_P0/USCI0_CLK/BPWM0_CH0/TM0_EXT
9	PA.10/ACMP1_P0/USCI0_DAT0/BPWM0_CH1/TM1_EXT
10	PA.9/USCI0_DAT1/UART1_TXD/BPWM0_CH2/TM2_EXT
11	PA.8/USCI0_CTL1/UART1_RXD/BPWM0_CH3/TM3_EXT/INT4
12	PF.6/SC0_CLK/SPI0_MOSI/TAMPER0
13	PF.14/PWM1_BRAKE0/PWM0_BRAKE0/PSIO0_CH3/PWM0_CH4/CLKO/TM3/INT5
14	PF.5/UART2_RXD/UART2_nCTS/PWM0_CH0/BPWM0_CH4/X32_IN/EADC0_ST
15	PF.4/UART2_TXD/UART2_nRTS/PWM0_CH1/BPWM0_CH5/X32_OUT
16	PF.3/UART0_TXD/I2C0_SCL/XT1_IN/BPWM1_CH0
17	PF.2/UART0_RXD/I2C0_SDA/QSPI0_CLK/XT1_OUT/BPWM1_CH1
18	PC.7/UART0_nCTS/I2C1_SMBAL/PWM1_CH2/BPWM1_CH0/TM0/INT3
19	PC.6/UART0_nRTS/I2C1_SMBSUS/PWM1_CH3/BPWM1_CH1/TM1/INT2
20	PA.7/UART0_TXD/I2C1_SCL/PWM1_CH4/BPWM1_CH2/ACMP0_WLAT/TM2/INT1
21	PA.6/UART0_RXD/I2C1_SDA/PWM1_CH5/BPWM1_CH3/ACMP1_WLAT/TM3/INT0
22	V <sub>SS</sub>
23	V <sub>DD</sub>
24	PD.15/PWM0_CH5/TM3/INT1
25	PA.5/QSPI0_MISO1/UART0_nCTS/UART0_TXD/I2C0_SCL/BPWM0_CH5/PWM0_CH0
26	PA.4/QSPI0_MOSI1/SPI0_I2SMCLK/SC0_nCD/UART0_nRTS/UART0_RXD/I2C0_SDA/BPWM0_CH4/PWM0_CH1
27	PA.3/QSPI0_SS/SPI0_SS/SC0_PWR/I2C0_SMBAL/UART1_TXD/I2C1_SCL/BPWM0_CH3/PWM0_CH2/CLKO/PWM1_BRAKE1
28	PA.2/QSPI0_CLK/SPI0_CLK/SC0_RST/I2C0_SMBSUS/UART1_RXD/I2C1_SDA/BPWM0_CH2/PWM0_CH3
29	PA.1/QSPI0_MISO0/SPI0_MISO/SC0_DAT/UART0_TXD/UART1_nCTS/BPWM0_CH1/PWM0_CH4
30	PA.0/QSPI0_MOSI0/SPI0_MOSI/SC0_CLK/UART0_RXD/UART1_nRTS/BPWM0_CH0/PWM0_CH5
31	V <sub>DDIO</sub>
32	nRESET <b>Note:</b> It is recommended to use 10 kΩ pull-up resistor and 10 uF capacitor on nRESET pin.
33	PF.0/UART1_TXD/I2C1_SCL/UART0_TXD/BPWM1_CH0/ICE_DAT <b>Note:</b> It is recommended to use 100 kΩ pull-up resistor on ICE_DAT pin.
34	PF.1/UART1_RXD/I2C1_SDA/UART0_RXD/BPWM1_CH1/ICE_CLK <b>Note:</b> It is recommended to use 100 kΩ pull-up resistor on ICE_CLK pin.
35	PC.5/QSPI0_MISO1/UART2_TXD/I2C1_SCL/PWM1_CH0/PSIO0_CH0

36	PC.4/QSPI0_MOSI1/UART2_RXD/I2C1_SDA/PWM1_CH1/PSIO0_CH1
37	PC.3/QSPI0_SS/UART2_nRTS/I2C0_SMBAL/PWM1_CH2/PSIO0_CH2
38	PC.2/QSPI0_CLK/UART2_nCTS/I2C0_SMBSUS/PWM1_CH3/PSIO0_CH3
39	PC.1/QSPI0_MISO0/UART2_TXD/I2C0_SCL/PWM1_CH4/ACMP0_O
40	PC.0/QSPI0_MOSI0/UART2_RXD/I2C0_SDA/PWM1_CH5/ACMP1_O
41	PD.3/USCI0_CTL1/SPI0_SS/USCI1_CTL0/UART0_TXD
42	PD.2/USCI0_DAT1/SPI0_CLK/UART0_RXD
43	PD.1/USCI0_DAT0/SPI0_MISO
44	PD.0/USCI0_CLK/SPI0_MOSI/TM2
45	PA.12/I2C1_SCL/BPWM1_CH2
46	PA.13/I2C1_SDA/BPWM1_CH3
47	PA.14/UART0_TXD/BPWM1_CH4
48	PA.15/UART0_RXD/BPWM1_CH5
49	V <sub>SS</sub>
50	LDO_CAP
51	V <sub>DD</sub>
52	PC.14/SPI0_I2SMCLK/USCI0_CTL0/QSPI0_CLK/TM1
53	PB.15/EADC0_CH15/SPI0_SS/USCI0_CTL1/UART0_nCTS/PSIO0_CH0/PWM1_CH0/TM0_EXT/PWM0_BRAKE1
54	PB.14/EADC0_CH14/SPI0_CLK/USCI0_DAT1/UART0_nRTS/PSIO0_CH1/PWM1_CH1/TM1_EXT/CLKO
55	PB.13/EADC0_CH13/ACMP0_P3/ACMP1_P3/SPI0_MISO/USCI0_DAT0/UART0_TXD/PSIO0_CH2/PWM1_CH2/TM2_EXT
56	PB.12/EADC0_CH12/ACMP0_P2/ACMP1_P2/SPI0_MOSI/USCI0_CLK/UART0_RXD/PSIO0_CH3/PWM1_CH3/TM3_EXT
57	AV <sub>DD</sub>
58	V <sub>REF</sub>
59	AV <sub>SS</sub>
60	PB.11/EADC0_CH11/UART0_nCTS/I2C1_SCL/SPI0_I2SMCLK/BPWM1_CH0
61	PB.10/EADC0_CH10/USCI1_CTL0/UART0_nRTS/I2C1_SDA/BPWM1_CH1
62	PB.9/EADC0_CH9/USCI1_CTL1/UART0_TXD/UART1_nCTS/I2C1_SMBAL/BPWM1_CH2
63	PB.8/EADC0_CH8/USCI1_CLK/UART0_RXD/UART1_nRTS/I2C1_SMBSUS/BPWM1_CH3
64	PB.7/EADC0_CH7/USCI1_DAT0/UART1_TXD/BPWM1_CH4/PWM1_BRAKE0/PWM1_CH4/INT5/ACMP0_O

Table 4.1-8 M251SC2AE/M251SD2AE Multi-function Pin Table

M251SE3AE

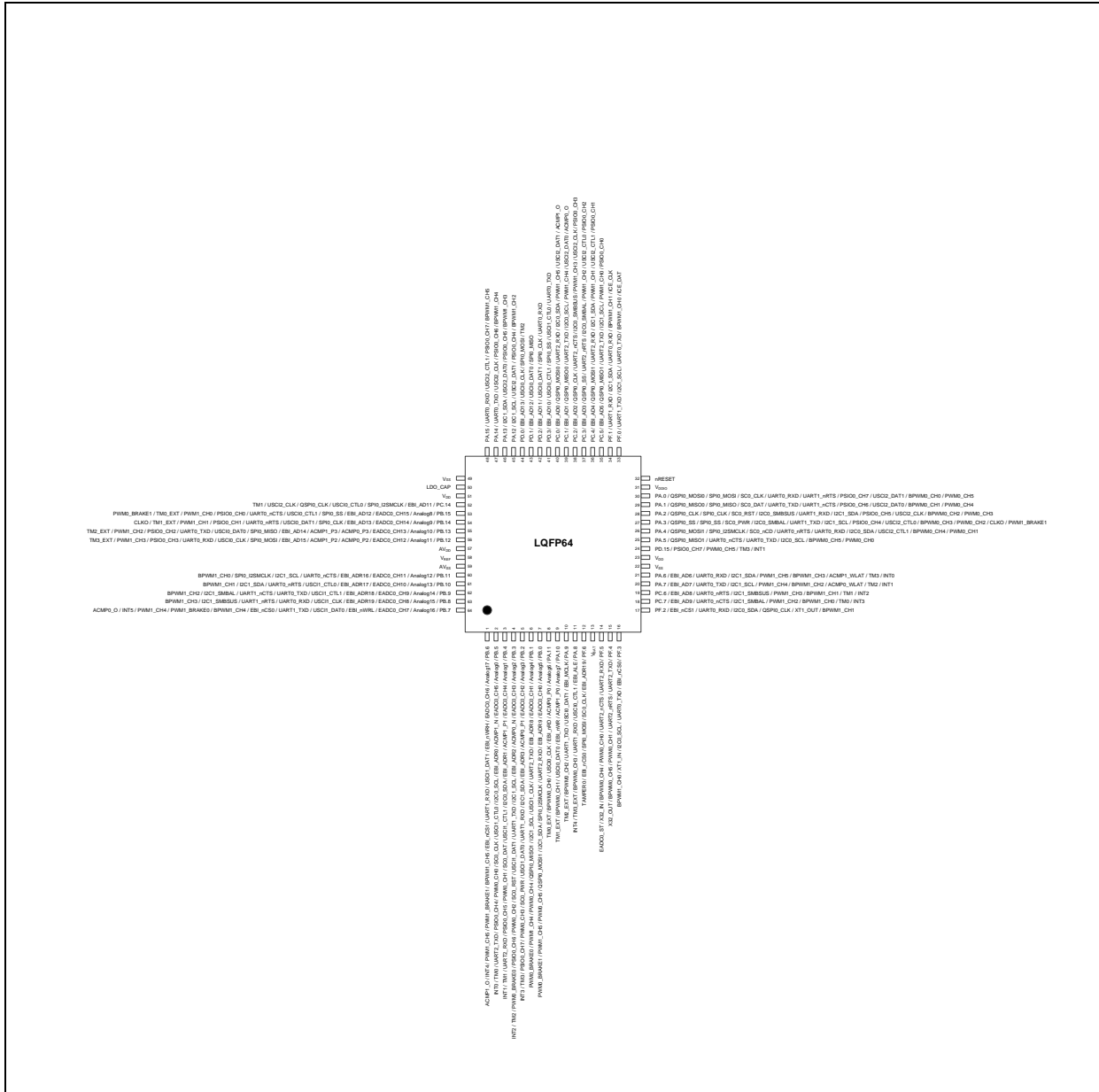

Figure 4.1-16 M251SE3AE Multi-function Pin Diagram

Pin	M251SE3AE Pin Function
1	PB.6/EADC0_CH6/EBI_nWRH/USC11_DAT1/UART1_RXD/EBI_nCS1/BPWM1_CH5/PWM1_BRAKE1/PWM1_CH5/INT4/ACMP1_0
2	PB.5/EADC0_CH5/ACMP1_N/EBI_ADR0/I2C0_SCL/USC11_CTL0/SC0_CLK/PWM0_CH0/PSIO0_CH4/UART2_TXD/TM0/INT0
3	PB.4/EADC0_CH4/ACMP1_P1/EBI_ADR1/I2C0_SDA/USC11_CTL1/SC0_DAT/PWM0_CH1/PSIO0_CH5/UART2_RXD/TM1/INT1
4	PB.3/EADC0_CH3/ACMP0_N/EBI_ADR2/I2C1_SCL/UART1_TXD/USC11_DAT1/SC0_RST/PWM0_CH2/PSIO0_CH6/PWM0_BRAKE0/TM2/INT2

5	PB.2/EADC0_CH2/ACMP0_P1/EBI_ADR3/I2C1_SDA/UART1_RXD/USCI1_DAT0/SC0_PWR/PWM0_CH3/PSIO0_CH7/TM3/INT3
6	PB.1/EADC0_CH1/EBI_ADR8/UART2_TXD/USCI1_CLK/I2C1_SCL/QSPI0_MISO1/PWM0_CH4/PWM1_CH4/PWM0_BRAKE0
7	PB.0/EADC0_CH0/EBI_ADR9/UART2_RXD/SPI0_I2SMCLK/I2C1_SDA/QSPI0_MOSI1/PWM0_CH5/PWM1_CH5/PWM0_BRAKE1
8	PA.11/ACMP0_P0/EBI_nRD/USCIO_CLK/BPWM0_CH0/TM0_EXT
9	PA.10/ACMP1_P0/EBI_nWR/USCIO_DAT0/BPWM0_CH1/TM1_EXT
10	PA.9/EBI_MCLK/USCIO_DAT1/UART1_TXD/BPWM0_CH2/TM2_EXT
11	PA.8/EBI_ALE/USCIO_CTL1/UART1_RXD/BPWM0_CH3/TM3_EXT/INT4
12	PF.6/EBI_ADR19/SC0_CLK/SPI0_MOSI/EBI_nCS0/TAMPER0
13	V <sub>BAT</sub>
14	PF.5/UART2_RXD/UART2_nCTS/PWM0_CH0/BPWM0_CH4/X32_IN/EADC0_ST
15	PF.4/UART2_TXD/UART2_nRTS/PWM0_CH1/BPWM0_CH5/X32_OUT
16	PF.3/EBI_nCS0/UART0_TXD/I2C0_SCL/XT1_IN/BPWM1_CH0
17	PF.2/EBI_nCS1/UART0_RXD/I2C0_SDA/QSPI0_CLK/XT1_OUT/BPWM1_CH1
18	PC.7/EBI_AD9/UART0_nCTS/I2C1_SMBAL/PWM1_CH2/BPWM1_CH0/TM0/INT3
19	PC.6/EBI_AD8/UART0_nRTS/I2C1_SMBSUS/PWM1_CH3/BPWM1_CH1/TM1/INT2
20	PA.7/EBI_AD7/UART0_TXD/I2C1_SCL/PWM1_CH4/BPWM1_CH2/ACMP0_WLAT/TM2/INT1
21	PA.6/EBI_AD6/UART0_RXD/I2C1_SDA/PWM1_CH5/BPWM1_CH3/ACMP1_WLAT/TM3/INT0
22	V <sub>SS</sub>
23	V <sub>DD</sub>
24	PD.15/PSIO0_CH7/PWM0_CH5/TM3/INT1
25	PA.5/QSPI0_MISO1/UART0_nCTS/UART0_TXD/I2C0_SCL/BPWM0_CH5/PWM0_CH0
26	PA.4/QSPI0_MOSI1/SPI0_I2SMCLK/SC0_nCD/UART0_nRTS/UART0_RXD/I2C0_SDA/USCI2_CTL1/BPWM0_CH4/PWM0_CH1
27	PA.3/QSPI0_SS/SPI0_SS/SC0_PWR/I2C0_SMBAL/UART1_TXD/I2C1_SCL/PSIO0_CH4/USCI2_CTL0/BPWM0_CH3/PWM0_CH2/CLKO/PWM1_BRAKE1
28	PA.2/QSPI0_CLK/SPI0_CLK/SC0_RST/I2C0_SMBSUS/UART1_RXD/I2C1_SDA/PSIO0_CH5/USCI2_CLK/BPWM0_CH2/PWM0_CH3
29	PA.1/QSPI0_MISO0/SPI0_MISO/SC0_DAT/UART0_TXD/UART1_nCTS/PSIO0_CH6/USCI2_DAT0/BPWM0_CH1/PWM0_CH4
30	PA.0/QSPI0_MOSI0/SPI0_MOSI/SC0_CLK/UART0_RXD/UART1_nRTS/PSIO0_CH7/USCI2_DAT1/BPWM0_CH0/PWM0_CH5
31	V <sub>DDIO</sub>
32	nRESET <b>Note:</b> It is recommended to use 10 kΩ pull-up resistor and 10 uF capacitor on nRESET pin.
33	PF.0/UART1_TXD/I2C1_SCL/UART0_TXD/BPWM1_CH0/ICE_DAT <b>Note:</b> It is recommended to use 100 kΩ pull-up resistor on ICE_DAT pin.
34	PF.1/UART1_RXD/I2C1_SDA/UART0_RXD/BPWM1_CH1/ICE_CLK

	<b>Note:</b> It is recommended to use 100 kΩ pull-up resistor on ICE_CLK pin.
35	PC.5/EBI_AD5/QSPI0_MISO1/UART2_TXD/I2C1_SCL/PWM1_CH0/PSIO0_CH0
36	PC.4/EBI_AD4/QSPI0_MOSI1/UART2_RXD/I2C1_SDA/PWM1_CH1/USCI2_CTL1/PSIO0_CH1
37	PC.3/EBI_AD3/QSPI0_SS/UART2_nRTS/I2C0_SMBAL/PWM1_CH2/USCI2_CTL0/PSIO0_CH2
38	PC.2/EBI_AD2/QSPI0_CLK/UART2_nCTS/I2C0_SMBUS/PWM1_CH3/USCI2_CLK/PSIO0_CH3
39	PC.1/EBI_AD1/QSPI0_MISO0/UART2_TXD/I2C0_SCL/PWM1_CH4/USCI2_DAT0/ACMP0_O
40	PC.0/EBI_AD0/QSPI0_MOSI0/UART2_RXD/I2C0_SDA/PWM1_CH5/USCI2_DAT1/ACMP1_O
41	PD.3/EBI_AD10/USCI0_CTL1/SPI0_SS/USCI1_CTL0/UART0_TXD
42	PD.2/EBI_AD11/USCI0_DAT1/SPI0_CLK/UART0_RXD
43	PD.1/EBI_AD12/USCI0_DAT0/SPI0_MISO
44	PD.0/EBI_AD13/USCI0_CLK/SPI0_MOSI/TM2
45	PA.12/I2C1_SCL/USCI2_DAT1/PSIO0_CH4/BPWM1_CH2
46	PA.13/I2C1_SDA/USCI2_DAT0/PSIO0_CH5/BPWM1_CH3
47	PA.14/UART0_TXD/USCI2_CLK/PSIO0_CH6/BPWM1_CH4
48	PA.15/UART0_RXD/USCI2_CTL1/PSIO0_CH7/BPWM1_CH5
49	V <sub>SS</sub>
50	LDO_CAP
51	V <sub>DD</sub>
52	PC.14/EBI_AD11/SPI0_I2SMCLK/USCI0_CTL0/QSPI0_CLK/USCI2_CLK/TM1
53	PB.15/EADC0_CH15/EBI_AD12/SPI0_SS/USCI0_CTL1/UART0_nCTS/PSIO0_CH0/PWM1_CH0/TM0_EXT/PWM0_BRAKE1
54	PB.14/EADC0_CH14/EBI_AD13/SPI0_CLK/USCI0_DAT1/UART0_nRTS/PSIO0_CH1/PWM1_CH1/TM1_EXT/CLKO
55	PB.13/EADC0_CH13/ACMP0_P3/ACMP1_P3/EBI_AD14/SPI0_MISO/USCI0_DAT0/UART0_TXD/PSIO0_CH2/PWM1_CH2/TM2_EXT
56	PB.12/EADC0_CH12/ACMP0_P2/ACMP1_P2/EBI_AD15/SPI0_MOSI/USCI0_CLK/UART0_RXD/PSIO0_CH3/PWM1_CH3/TM3_EXT
57	AV <sub>DD</sub>
58	V <sub>REF</sub>
59	AV <sub>SS</sub>
60	PB.11/EADC0_CH11/EBI_ADR16/UART0_nCTS/I2C1_SCL/SPI0_I2SMCLK/BPWM1_CH0
61	PB.10/EADC0_CH10/EBI_ADR17/USCI1_CTL0/UART0_nRTS/I2C1_SDA/BPWM1_CH1
62	PB.9/EADC0_CH9/EBI_ADR18/USCI1_CTL1/UART0_TXD/UART1_nCTS/I2C1_SMBAL/BPWM1_CH2
63	PB.8/EADC0_CH8/EBI_ADR19/USCI1_CLK/UART0_RXD/UART1_nRTS/I2C1_SMBUS/BPWM1_CH3
64	PB.7/EADC0_CH7/EBI_nWRL/USCI1_DAT0/UART1_TXD/EBI_nCS0/BPWM1_CH4/PWM1_BRAKE0/PWM1_CH4/INT5/ACMP0_O

Table 4.1-9 M251SE3AE Multi-function Pin Table

M251SG6AE

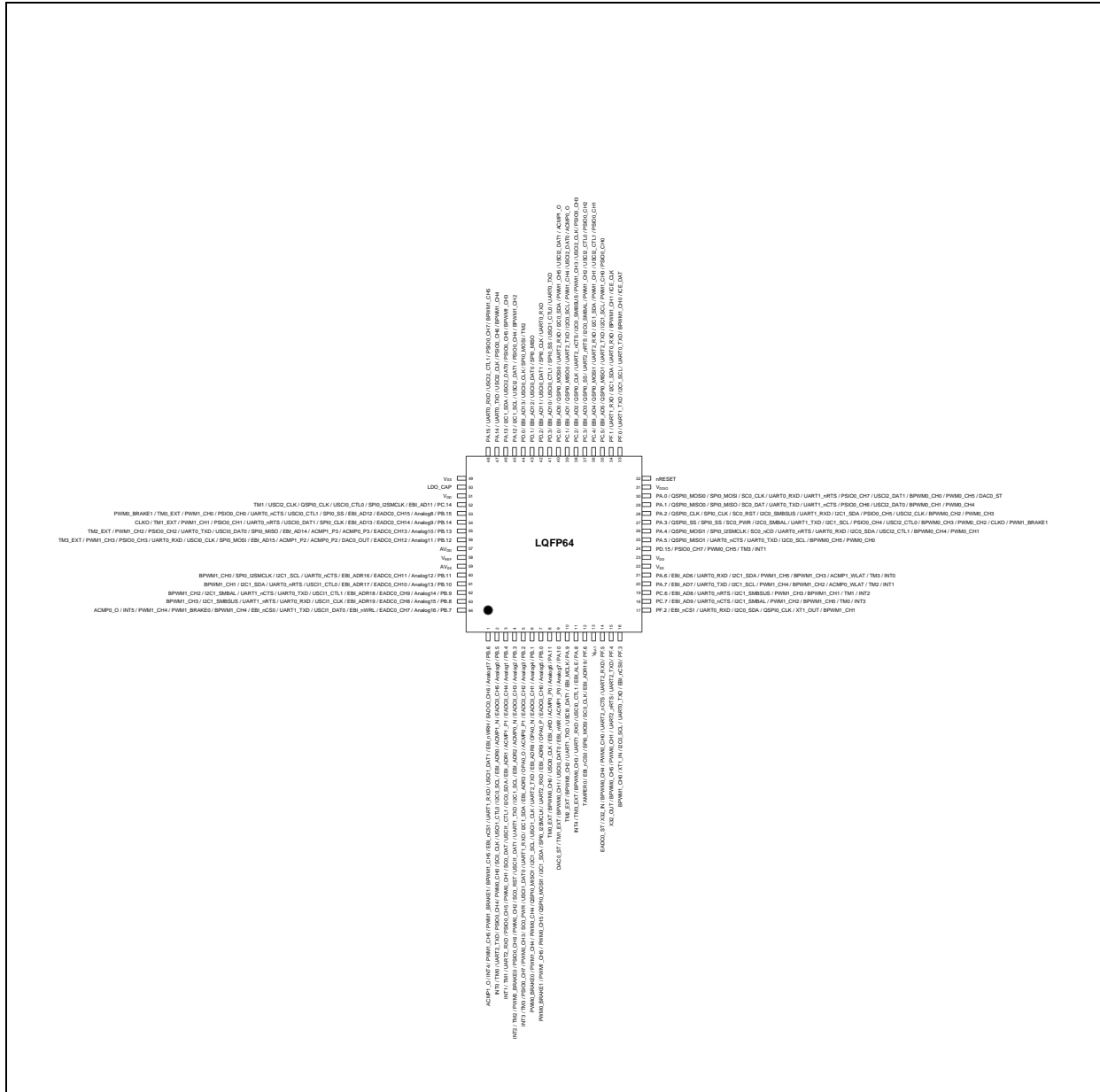

Figure 4.1-17 M251SG6AE Multi-function Pin Diagram

Pin	M251SG6AE Pin Function
1	PB.6/EADC0_CH6/EBI_nWRH/USC11_DAT1/UART1_RXD/EBI_nCS1/BPWM1_CH5/PWM1_BRAKE1/PWM1_CH5/INT4/ACMP1_0
2	PB.5/EADC0_CH5/ACMP1_N/EBI_ADR0/I2C0_SCL/USC11_CTL0/SC0_CLK/PWM0_CH0/PSIO0_CH4/UART2_TXD/TM0/INT0
3	PB.4/EADC0_CH4/ACMP1_P1/EBI_ADR1/I2C0_SDA/USC11_CTL1/SC0_DAT/PWM0_CH1/PSIO0_CH5/UART2_RXD/TM1/INT1
4	PB.3/EADC0_CH3/ACMP0_N/EBI_ADR2/I2C1_SCL/UART1_TXD/USC11_DAT1/SC0_RST/PWM0_CH2/PSIO0_CH6/PWM0_BRAKE0/TM2/INT2

5	PB.2/EADC0_CH2/ACMP0_P1/OPA0_O/EBI_ADR3/I2C1_SDA/UART1_RXD/USCI1_DAT0/SC0_PWR/PWM0_CH3/P SIO0_CH7/TM3/INT3
6	PB.1/EADC0_CH1/OPA0_N/EBI_ADR8/UART2_TXD/USCI1_CLK/I2C1_SCL/QSPI0_MISO1/PWM0_CH4/PWM1_CH 4/PWM0_BRAKE0
7	PB.0/EADC0_CH0/OPA0_P/EBI_ADR9/UART2_RXD/SPI0_I2SMCLK/I2C1_SDA/QSPI0_MOSI1/PWM0_CH5/PWM1_ CH5/PWM0_BRAKE1
8	PA.11/ACMP0_P0/EBI_nRD/USCI0_CLK/BPWM0_CH0/TM0_EXT
9	PA.10/ACMP1_P0/EBI_nWR/USCI0_DAT0/BPWM0_CH1/TM1_EXT/DAC0_ST
10	PA.9/EBI_MCLK/USCI0_DAT1/UART1_TXD/BPWM0_CH2/TM2_EXT
11	PA.8/EBI_ALE/USCI0_CTL1/UART1_RXD/BPWM0_CH3/TM3_EXT/INT4
12	PF.6/EBI_ADR19/SC0_CLK/SPI0_MOSI/EBI_nCS0/TAMPER0
13	V <sub>BAT</sub>
14	PF.5/UART2_RXD/UART2_nCTS/PWM0_CH0/BPWM0_CH4/X32_IN/EADC0_ST
15	PF.4/UART2_TXD/UART2_nRTS/PWM0_CH1/BPWM0_CH5/X32_OUT
16	PF.3/EBI_nCS0/UART0_TXD/I2C0_SCL/XT1_IN/BPWM1_CH0
17	PF.2/EBI_nCS1/UART0_RXD/I2C0_SDA/QSPI0_CLK/XT1_OUT/BPWM1_CH1
18	PC.7/EBI_AD9/UART0_nCTS/I2C1_SMBAL/PWM1_CH2/BPWM1_CH0/TM0/INT3
19	PC.6/EBI_AD8/UART0_nRTS/I2C1_SMBSUS/PWM1_CH3/BPWM1_CH1/TM1/INT2
20	PA.7/EBI_AD7/UART0_TXD/I2C1_SCL/PWM1_CH4/BPWM1_CH2/ACMP0_WLAT/TM2/INT1
21	PA.6/EBI_AD6/UART0_RXD/I2C1_SDA/PWM1_CH5/BPWM1_CH3/ACMP1_WLAT/TM3/INT0
22	V <sub>SS</sub>
23	V <sub>DD</sub>
24	PD.15/PSIO0_CH7/PWM0_CH5/TM3/INT1
25	PA.5/QSPI0_MISO1/UART0_nCTS/UART0_TXD/I2C0_SCL/BPWM0_CH5/PWM0_CH0
26	PA.4/QSPI0_MOSI1/SPI0_I2SMCLK/SC0_nCD/UART0_nRTS/UART0_RXD/I2C0_SDA/USCI2_CTL1/BPWM0_CH4/P WM0_CH1
27	PA.3/QSPI0_SS/SPI0_SS/SC0_PWR/I2C0_SMBAL/UART1_TXD/I2C1_SCL/PSIO0_CH4/USCI2_CTL0/BPWM0_CH3/ PWM0_CH2/CLKO/PWM1_BRAKE1
28	PA.2/QSPI0_CLK/SPI0_CLK/SC0_RST/I2C0_SMBSUS/UART1_RXD/I2C1_SDA/PSIO0_CH5/USCI2_CLK/BPWM0_C H2/PWM0_CH3
29	PA.1/QSPI0_MISO0/SPI0_MISO/SC0_DAT/UART0_TXD/UART1_nCTS/PSIO0_CH6/USCI2_DAT0/BPWM0_CH1/PW M0_CH4
30	PA.0/QSPI0_MOSI0/SPI0_MOSI/SC0_CLK/UART0_RXD/UART1_nRTS/PSIO0_CH7/USCI2_DAT1/BPWM0_CH0/PW M0_CH5/DAC0_ST
31	V <sub>DDIO</sub>
32	nRESET <b>Note:</b> It is recommended to use 10 kΩ pull-up resistor and 10 uF capacitor on nRESET pin.
33	PF.0/UART1_TXD/I2C1_SCL/UART0_TXD/BPWM1_CH0/ICE_DAT <b>Note:</b> It is recommended to use 100 kΩ pull-up resistor on ICE_DAT pin.
34	PF.1/UART1_RXD/I2C1_SDA/UART0_RXD/BPWM1_CH1/ICE_CLK

	<b>Note:</b> It is recommended to use 100 kΩ pull-up resistor on ICE_CLK pin.
35	PC.5/EBI_AD5/QSPI0_MISO1/UART2_TXD/I2C1_SCL/PWM1_CH0/PSIO0_CH0
36	PC.4/EBI_AD4/QSPI0_MOSI1/UART2_RXD/I2C1_SDA/PWM1_CH1/USCI2_CTL1/PSIO0_CH1
37	PC.3/EBI_AD3/QSPI0_SS/UART2_nRTS/I2C0_SMBAL/PWM1_CH2/USCI2_CTL0/PSIO0_CH2
38	PC.2/EBI_AD2/QSPI0_CLK/UART2_nCTS/I2C0_SMBUS/PWM1_CH3/USCI2_CLK/PSIO0_CH3
39	PC.1/EBI_AD1/QSPI0_MISO0/UART2_TXD/I2C0_SCL/PWM1_CH4/USCI2_DAT0/ACMP0_O
40	PC.0/EBI_AD0/QSPI0_MOSI0/UART2_RXD/I2C0_SDA/PWM1_CH5/USCI2_DAT1/ACMP1_O
41	PD.3/EBI_AD10/USCI0_CTL1/SPI0_SS/USCI1_CTL0/UART0_TXD
42	PD.2/EBI_AD11/USCI0_DAT1/SPI0_CLK/UART0_RXD
43	PD.1/EBI_AD12/USCI0_DAT0/SPI0_MISO
44	PD.0/EBI_AD13/USCI0_CLK/SPI0_MOSI/TM2
45	PA.12/I2C1_SCL/USCI2_DAT1/PSIO0_CH4/BPWM1_CH2
46	PA.13/I2C1_SDA/USCI2_DAT0/PSIO0_CH5/BPWM1_CH3
47	PA.14/UART0_TXD/USCI2_CLK/PSIO0_CH6/BPWM1_CH4
48	PA.15/UART0_RXD/USCI2_CTL1/PSIO0_CH7/BPWM1_CH5
49	V <sub>SS</sub>
50	LDO_CAP
51	V <sub>DD</sub>
52	PC.14/EBI_AD11/SPI0_I2SMCLK/USCI0_CTL0/QSPI0_CLK/USCI2_CLK/TM1
53	PB.15/EADC0_CH15/EBI_AD12/SPI0_SS/USCI0_CTL1/UART0_nCTS/PSIO0_CH0/PWM1_CH0/TM0_EXT/PWM0_BRAKE1
54	PB.14/EADC0_CH14/EBI_AD13/SPI0_CLK/USCI0_DAT1/UART0_nRTS/PSIO0_CH1/PWM1_CH1/TM1_EXT/CLKO
55	PB.13/EADC0_CH13/ACMP0_P3/ACMP1_P3/EBI_AD14/SPI0_MISO/USCI0_DAT0/UART0_TXD/PSIO0_CH2/PWM1_CH2/TM2_EXT
56	PB.12/EADC0_CH12/DAC0_OUT/ACMP0_P2/ACMP1_P2/EBI_AD15/SPI0_MOSI/USCI0_CLK/UART0_RXD/PSIO0_CH3/PWM1_CH3/TM3_EXT
57	AV <sub>DD</sub>
58	V <sub>REF</sub>
59	AV <sub>SS</sub>
60	PB.11/EADC0_CH11/EBI_ADR16/UART0_nCTS/I2C1_SCL/SPI0_I2SMCLK/BPWM1_CH0
61	PB.10/EADC0_CH10/EBI_ADR17/USCI1_CTL0/UART0_nRTS/I2C1_SDA/BPWM1_CH1
62	PB.9/EADC0_CH9/EBI_ADR18/USCI1_CTL1/UART0_TXD/UART1_nCTS/I2C1_SMBAL/BPWM1_CH2
63	PB.8/EADC0_CH8/EBI_ADR19/USCI1_CLK/UART0_RXD/UART1_nRTS/I2C1_SMBUS/BPWM1_CH3
64	PB.7/EADC0_CH7/EBI_nWRL/USCI1_DAT0/UART1_TXD/EBI_nCS0/BPWM1_CH4/PWM1_BRAKE0/PWM1_CH4/INT5/ACMP0_O

Table 4.1-10 M251SG6AE Multi-function Pin Table

4.1.2.6 M251 Series LQFP 128-Pin Multi-function Pin Diagram

Corresponding Part Number: M251KE3AE, M251KG3AE

M251KE3AE

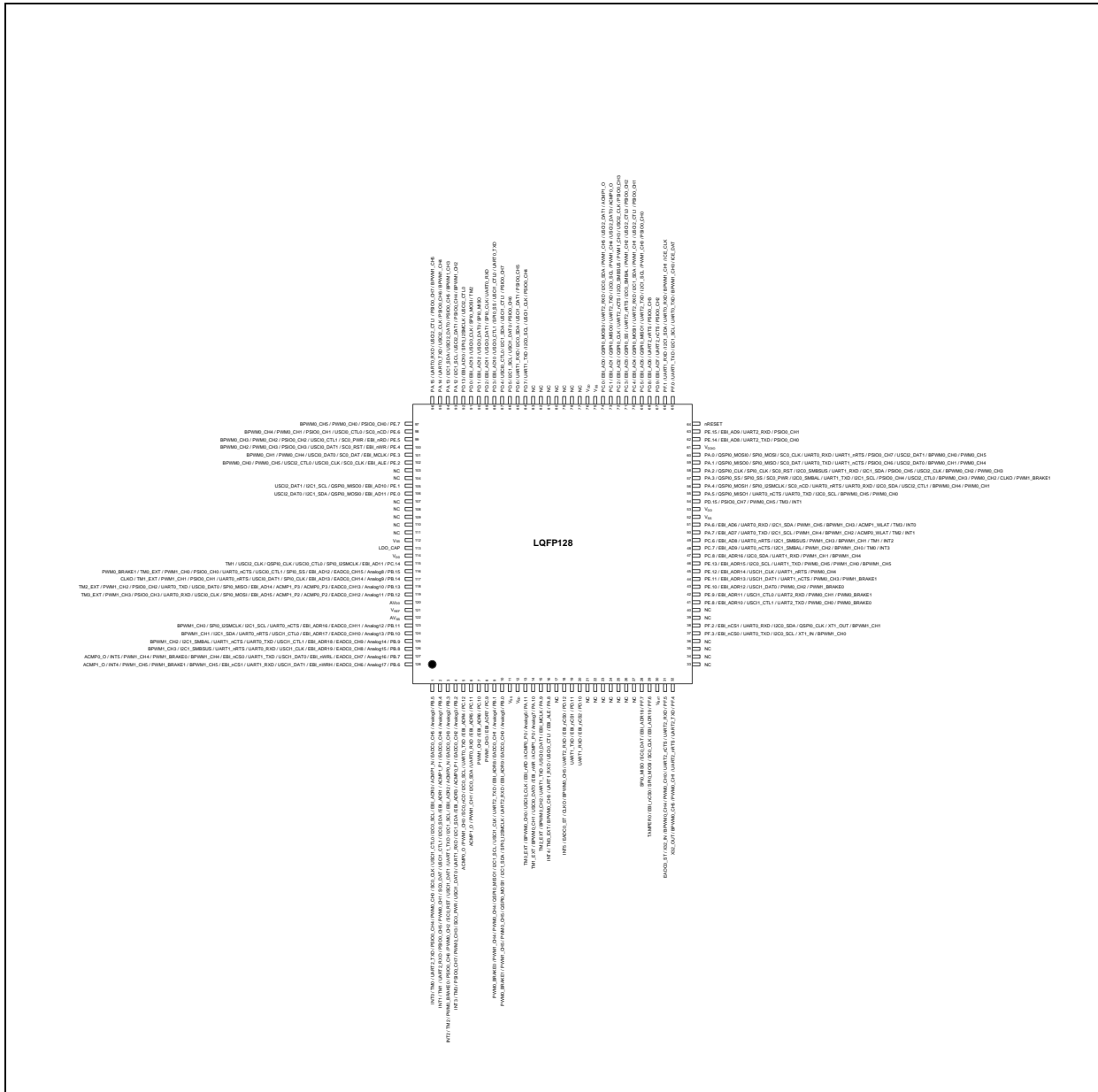

M251/M252 SERIES DATASHEET

Figure 4.1-18 M251KE3AE Multi-function Pin Diagram

Pin	M251KE3AE Pin Function
1	PB.5/EADC0_CH5/ACMP1_N/EBI_ADR0/I2C0_SCL/USC1_CTL0/SC0_CLK/PWM0_CH0/PSIO0_CH4/UART2_TXD/TM0/INT0
2	PB.4/EADC0_CH4/ACMP1_P1/EBI_ADR1/I2C0_SDA/USC1_CTL1/SC0_DAT/PWM0_CH1/PSIO0_CH5/UART2_RXD/TM1/INT1

3	PB.3/EADC0_CH3/ACMP0_N/EBI_ADR2/I2C1_SCL/UART1_TXD/USCI1_DAT1/SC0_RST/PWM0_CH2/PSIO0_CH6/PWM0_BRAKE0/TM2/INT2
4	PB.2/EADC0_CH2/ACMP0_P1/EBI_ADR3/I2C1_SDA/UART1_RXD/USCI1_DAT0/SC0_PWR/PWM0_CH3/PSIO0_CH7/TM3/INT3
5	PC.12/EBI_ADR4/UART0_TXD/I2C0_SCL/SC0_nCD/PWM1_CH0/ACMP0_O
6	PC.11/EBI_ADR5/UART0_RXD/I2C0_SDA/PWM1_CH1/ACMP1_O
7	PC.10/EBI_ADR6/PWM1_CH2
8	PC.9/EBI_ADR7/PWM1_CH3
9	PB.1/EADC0_CH1/EBI_ADR8/UART2_TXD/USCI1_CLK/I2C1_SCL/QSPI0_MISO1/PWM0_CH4/PWM1_CH4/PWM0_BRAKE0
10	PB.0/EADC0_CH0/EBI_ADR9/UART2_RXD/SPI0_I2SMCLK/I2C1_SDA/QSPI0_MOSI1/PWM0_CH5/PWM1_CH5/PWM0_BRAKE1
11	V <sub>SS</sub>
12	V <sub>DD</sub>
13	PA.11/ACMP0_P0/EBI_nRD/USCI0_CLK/BPWM0_CH0/TM0_EXT
14	PA.10/ACMP1_P0/EBI_nWR/USCI0_DAT0/BPWM0_CH1/TM1_EXT
15	PA.9/EBI_MCLK/USCI0_DAT1/UART1_TXD/BPWM0_CH2/TM2_EXT
16	PA.8/EBI_ALE/USCI0_CTL1/UART1_RXD/BPWM0_CH3/TM3_EXT/INT4
17	NC
18	PD.12/EBI_nCS0/UART2_RXD/BPWM0_CH5/CLKO/EADC0_ST/INT5
19	PD.11/EBI_nCS1/UART1_TXD
20	PD.10/EBI_nCS2/UART1_RXD
21	NC
22	NC
23	NC
24	NC
25	NC
26	NC
27	NC
28	PF.7/EBI_ADR18/SC0_DAT/SPI0_MISO
29	PF.6/EBI_ADR19/SC0_CLK/SPI0_MOSI/EBI_nCS0/TAMPER0
30	V <sub>BAT</sub>
31	PF.5/UART2_RXD/UART2_nCTS/PWM0_CH0/BPWM0_CH4/X32_IN/EADC0_ST
32	PF.4/UART2_TXD/UART2_nRTS/PWM0_CH1/BPWM0_CH5/X32_OUT
33	NC
34	NC
35	NC
36	NC

37	PF.3/EBI_nCS0/UART0_TXD/I2C0_SCL/XT1_IN/BPWM1_CH0
38	PF.2/EBI_nCS1/UART0_RXD/I2C0_SDA/QSPI0_CLK/XT1_OUT/BPWM1_CH1
39	NC
40	NC
41	PE.8/EBI_ADR10/USCI1_CTL1/UART2_TXD/PWM0_CH0/PWM0_BRAKE0
42	PE.9/EBI_ADR11/USCI1_CTL0/UART2_RXD/PWM0_CH1/PWM0_BRAKE1
43	PE.10/EBI_ADR12/USCI1_DAT0/PWM0_CH2/PWM1_BRAKE0
44	PE.11/EBI_ADR13/USCI1_DAT1/UART1_nCTS/PWM0_CH3/PWM1_BRAKE1
45	PE.12/EBI_ADR14/USCI1_CLK/UART1_nRTS/PWM0_CH4
46	PE.13/EBI_ADR15/I2C0_SCL/UART1_TXD/PWM0_CH5/PWM1_CH0/BPWM1_CH5
47	PC.8/EBI_ADR16/I2C0_SDA/UART1_RXD/PWM1_CH1/BPWM1_CH4
48	PC.7/EBI_AD9/UART0_nCTS/I2C1_SMBAL/PWM1_CH2/BPWM1_CH0/TM0/INT3
49	PC.6/EBI_AD8/UART0_nRTS/I2C1_SMBSUS/PWM1_CH3/BPWM1_CH1/TM1/INT2
50	PA.7/EBI_AD7/UART0_TXD/I2C1_SCL/PWM1_CH4/BPWM1_CH2/ACMP0_WLAT/TM2/INT1
51	PA.6/EBI_AD6/UART0_RXD/I2C1_SDA/PWM1_CH5/BPWM1_CH3/ACMP1_WLAT/TM3/INT0
52	V <sub>SS</sub>
53	V <sub>DD</sub>
54	PD.15/PSIO0_CH7/PWM0_CH5/TM3/INT1
55	PA.5/QSPI0_MISO1/UART0_nCTS/UART0_TXD/I2C0_SCL/BPWM0_CH5/PWM0_CH0
56	PA.4/QSPI0_MOSI1/SPI0_I2SMCLK/SC0_nCD/UART0_nRTS/UART0_RXD/I2C0_SDA/USCI2_CTL1/BPWM0_CH4/PWM0_CH1
57	PA.3/QSPI0_SS/SPI0_SS/SC0_PWR/I2C0_SMBAL/UART1_TXD/I2C1_SCL/PSIO0_CH4/USCI2_CTL0/BPWM0_CH3/PWM0_CH2/CLKO/PWM1_BRAKE1
58	PA.2/QSPI0_CLK/SPI0_CLK/SC0_RST/I2C0_SMBSUS/UART1_RXD/I2C1_SDA/PSIO0_CH5/USCI2_CLK/BPWM0_CH2/PWM0_CH3
59	PA.1/QSPI0_MISO0/SPI0_MISO/SC0_DAT/UART0_TXD/UART1_nCTS/PSIO0_CH6/USCI2_DAT0/BPWM0_CH1/PWM0_CH4
60	PA.0/QSPI0_MOSI0/SPI0_MOSI/SC0_CLK/UART0_RXD/UART1_nRTS/PSIO0_CH7/USCI2_DAT1/BPWM0_CH0/PWM0_CH5
61	V <sub>DDIO</sub>
62	PE.14/EBI_AD8/UART2_TXD/PSIO0_CH0
63	PE.15/EBI_AD9/UART2_RXD/PSIO0_CH1
64	nRESET <b>Note:</b> It is recommended to use 10 kΩ pull-up resistor and 10 uF capacitor on nRESET pin.
65	PF.0/UART1_TXD/I2C1_SCL/UART0_TXD/BPWM1_CH0/ICE_DAT <b>Note:</b> It is recommended to use 100 kΩ pull-up resistor on ICE_DAT pin.
66	PF.1/UART1_RXD/I2C1_SDA/UART0_RXD/BPWM1_CH1/ICE_CLK <b>Note:</b> It is recommended to use 100 kΩ pull-up resistor on ICE_CLK pin.
67	PD.9/EBI_AD7/UART2_nCTS/PSIO0_CH2

68	PD.8/EBI_AD6/UART2_nRTS/PSIO0_CH3
69	PC.5/EBI_AD5/QSPI0_MISO1/UART2_TXD/I2C1_SCL/PWM1_CH0/PSIO0_CH0
70	PC.4/EBI_AD4/QSPI0_MOSI1/UART2_RXD/I2C1_SDA/PWM1_CH1/USCI2_CTL1/PSIO0_CH1
71	PC.3/EBI_AD3/QSPI0_SS/UART2_nRTS/I2C0_SMBAL/PWM1_CH2/USCI2_CTL0/PSIO0_CH2
72	PC.2/EBI_AD2/QSPI0_CLK/UART2_nCTS/I2C0_SMBUS/PWM1_CH3/USCI2_CLK/PSIO0_CH3
73	PC.1/EBI_AD1/QSPI0_MISO0/UART2_TXD/I2C0_SCL/PWM1_CH4/USCI2_DAT0/ACMP0_O
74	PC.0/EBI_AD0/QSPI0_MOSI0/UART2_RXD/I2C0_SDA/PWM1_CH5/USCI2_DAT1/ACMP1_O
75	V <sub>SS</sub>
76	V <sub>DD</sub>
77	NC
78	NC
79	NC
80	NC
81	NC
82	NC
83	NC
84	PD.7/UART1_TXD/I2C0_SCL/USCI1_CLK/PSIO0_CH4
85	PD.6/UART1_RXD/I2C0_SDA/USCI1_DAT1/PSIO0_CH5
86	PD.5/I2C1_SCL/USCI1_DAT0/PSIO0_CH6
87	PD.4/USCI0_CTL0/I2C1_SDA/USCI1_CTL1/PSIO0_CH7
88	PD.3/EBI_AD10/USCI0_CTL1/SPI0_SS/USCI1_CTL0/UART0_TXD
89	PD.2/EBI_AD11/USCI0_DAT1/SPI0_CLK/UART0_RXD
90	PD.1/EBI_AD12/USCI0_DAT0/SPI0_MISO
91	PD.0/EBI_AD13/USCI0_CLK/SPI0_MOSI/TM2
92	PD.13/EBI_AD10/SPI0_I2SMCLK/USCI2_CTL0
93	PA.12/I2C1_SCL/USCI2_DAT1/PSIO0_CH4/BPWM1_CH2
94	PA.13/I2C1_SDA/USCI2_DAT0/PSIO0_CH5/BPWM1_CH3
95	PA.14/UART0_TXD/USCI2_CLK/PSIO0_CH6/BPWM1_CH4
96	PA.15/UART0_RXD/USCI2_CTL1/PSIO0_CH7/BPWM1_CH5
97	PE.7/PSIO0_CH0/PWM0_CH0/BPWM0_CH5
98	PE.6/SC0_nCD/USCI0_CTL0/PSIO0_CH1/PWM0_CH1/BPWM0_CH4
99	PE.5/EBI_nRD/SC0_PWR/USCI0_CTL1/PSIO0_CH2/PWM0_CH2/BPWM0_CH3
100	PE.4/EBI_nWR/SC0_RST/USCI0_DAT1/PSIO0_CH3/PWM0_CH3/BPWM0_CH2
101	PE.3/EBI_MCLK/SC0_DAT/USCI0_DAT0/PWM0_CH4/BPWM0_CH1
102	PE.2/EBI_ALE/SC0_CLK/USCI0_CLK/USCI2_CTL0/PWM0_CH5/BPWM0_CH0
103	NC

104	NC
105	PE.1/EBI_AD10/QSPI0_MISO0/I2C1_SCL/USCI2_DAT1
106	PE.0/EBI_AD11/QSPI0_MOSI0/I2C1_SDA/USCI2_DAT0
107	NC
108	NC
109	NC
110	NC
111	NC
112	V <sub>SS</sub>
113	LDO_CAP
114	V <sub>DD</sub>
115	PC.14/EBI_AD11/SPI0_I2SMCLK/USCI0_CTL0/QSPI0_CLK/USCI2_CLK/TM1
116	PB.15/EADC0_CH15/EBI_AD12/SPI0_SS/USCI0_CTL1/UART0_nCTS/PSIO0_CH0/PWM1_CH0/TM0_EXT/PWM0_BRAKE1
117	PB.14/EADC0_CH14/EBI_AD13/SPI0_CLK/USCI0_DAT1/UART0_nRTS/PSIO0_CH1/PWM1_CH1/TM1_EXT/CLKO
118	PB.13/EADC0_CH13/ACMP0_P3/ACMP1_P3/EBI_AD14/SPI0_MISO/USCI0_DAT0/UART0_TXD/PSIO0_CH2/PWM1_CH2/TM2_EXT
119	PB.12/EADC0_CH12/ACMP0_P2/ACMP1_P2/EBI_AD15/SPI0_MOSI/USCI0_CLK/UART0_RXD/PSIO0_CH3/PWM1_CH3/TM3_EXT
120	AV <sub>DD</sub>
121	V <sub>REF</sub>
122	AV <sub>SS</sub>
123	PB.11/EADC0_CH11/EBI_ADR16/UART0_nCTS/I2C1_SCL/SPI0_I2SMCLK/BPWM1_CH0
124	PB.10/EADC0_CH10/EBI_ADR17/USCI1_CTL0/UART0_nRTS/I2C1_SDA/BPWM1_CH1
125	PB.9/EADC0_CH9/EBI_ADR18/USCI1_CTL1/UART0_TXD/UART1_nCTS/I2C1_SMBAL/BPWM1_CH2
126	PB.8/EADC0_CH8/EBI_ADR19/USCI1_CLK/UART0_RXD/UART1_nRTS/I2C1_SMBSUS/BPWM1_CH3
127	PB.7/EADC0_CH7/EBI_nWRL/USCI1_DAT0/UART1_TXD/EBI_nCS0/BPWM1_CH4/PWM1_BRAKE0/PWM1_CH4/INT5/ACMP0_O
128	PB.6/EADC0_CH6/EBI_nWRH/USCI1_DAT1/UART1_RXD/EBI_nCS1/BPWM1_CH5/PWM1_BRAKE1/PWM1_CH5/INT4/ACMP1_O

Table 4.1-11 M251KE3AE Multi-function Pin Table

M251KG6AE

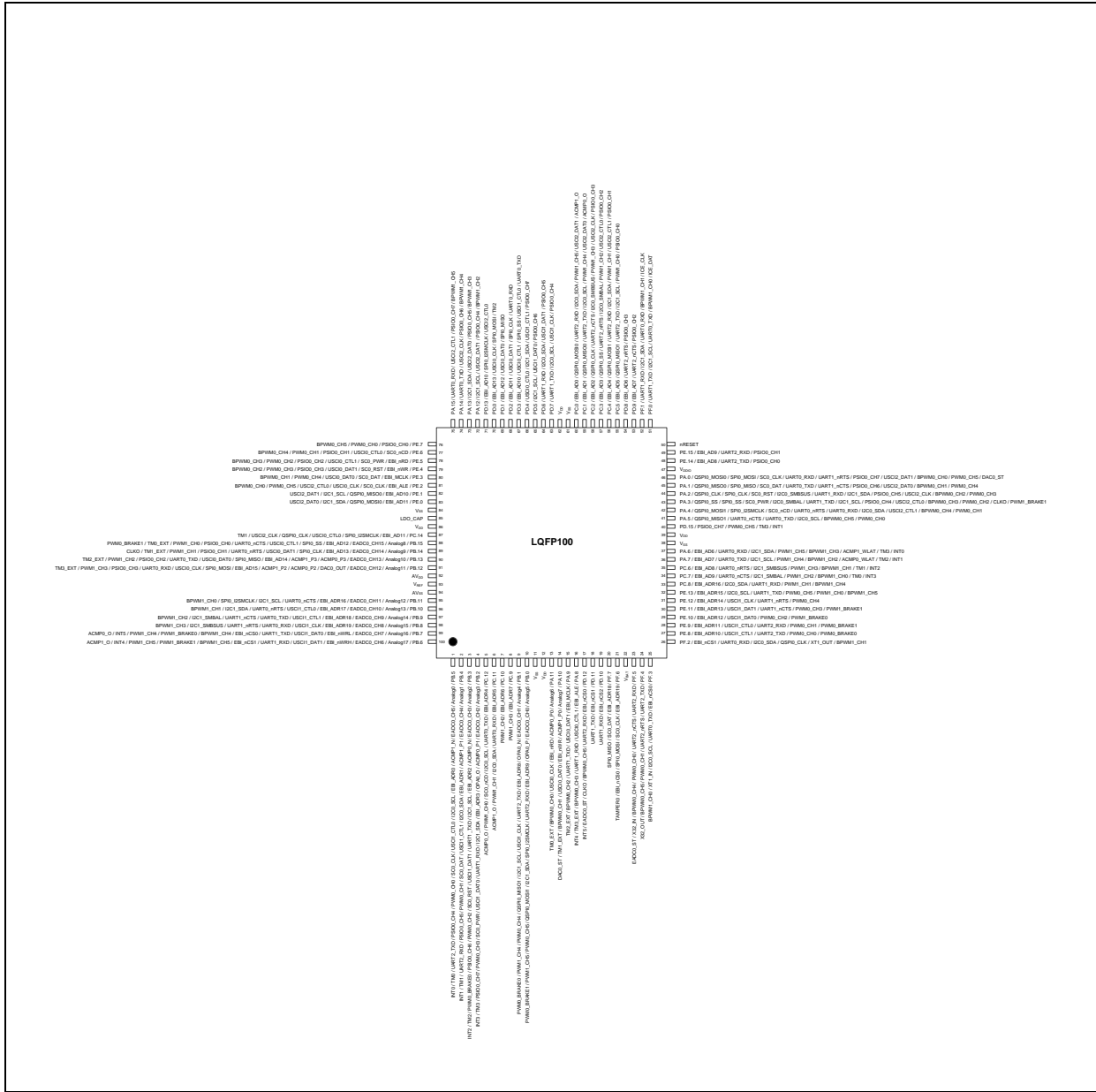

Figure 4.1-19 M251KG6AE Multi-function Pin Diagram

Pin	M251KG6AE Pin Function
1	PB.5/EADC0_CH5/ACMP1_N/EBI_ADR0/I2C0_SCL/USC1_CTL0/SC0_CLK/PWM0_CH0/PSIO0_CH4/UART2_TXD/TM0/INT0
2	PB.4/EADC0_CH4/ACMP1_P1/EBI_ADR1/I2C0_SDA/USC1_CTL1/SC0_DAT/PWM0_CH1/PSIO0_CH5/UART2_RXD/TM1/INT1
3	PB.3/EADC0_CH3/ACMP0_N/EBI_ADR2/I2C1_SCL/UART1_TXD/USC1_DAT1/SC0_RST/PWM0_CH2/PSIO0_CH6/PWM0_BRAKE0/TM2/INT2
4	PB.2/EADC0_CH2/ACMP0_P1/OPA0_O/EBI_ADR3/I2C1_SDA/UART1_RXD/USC1_DAT0/SC0_PWR/PWM0_CH3/PSIO0_CH7/TM3/INT3

5	PC.12/EBI_ADR4/UART0_TXD/I2C0_SCL/SC0_nCD/PWM1_CH0/ACMP0_O
6	PC.11/EBI_ADR5/UART0_RXD/I2C0_SDA/PWM1_CH1/ACMP1_O
7	PC.10/EBI_ADR6/PWM1_CH2
8	PC.9/EBI_ADR7/PWM1_CH3
9	PB.1/EADC0_CH1/OPA0_N/EBI_ADR8/UART2_TXD/USCI1_CLK/I2C1_SCL/QSPI0_MISO1/PWM0_CH4/PWM1_CH4/PWM0_BRAKE0
10	PB.0/EADC0_CH0/OPA0_P/EBI_ADR9/UART2_RXD/SPI0_I2SMCLK/I2C1_SDA/QSPI0_MOSI1/PWM0_CH5/PWM1_CH5/PWM0_BRAKE1
11	V <sub>SS</sub>
12	V <sub>DD</sub>
13	PA.11/ACMP0_P0/EBI_nRD/USCI0_CLK/BPWM0_CH0/TM0_EXT
14	PA.10/ACMP1_P0/EBI_nWR/USCI0_DAT0/BPWM0_CH1/TM1_EXT/DAC0_ST
15	PA.9/EBI_MCLK/USCI0_DAT1/UART1_TXD/BPWM0_CH2/TM2_EXT
16	PA.8/EBI_ALE/USCI0_CTL1/UART1_RXD/BPWM0_CH3/TM3_EXT/INT4
17	NC
18	PD.12/EBI_nCS0/UART2_RXD/BPWM0_CH5/CLKO/EADC0_ST/INT5
19	PD.11/EBI_nCS1/UART1_TXD
20	PD.10/EBI_nCS2/UART1_RXD
21	NC
22	NC
23	NC
24	NC
25	NC
26	NC
27	NC
28	PF.7/EBI_ADR18/SC0_DAT/SPI0_MISO
29	PF.6/EBI_ADR19/SC0_CLK/SPI0_MOSI/EBI_nCS0/TAMPER0
30	V <sub>BAT</sub>
31	PF.5/UART2_RXD/UART2_nCTS/PWM0_CH0/BPWM0_CH4/X32_IN/EADC0_ST
32	PF.4/UART2_TXD/UART2_nRTS/PWM0_CH1/BPWM0_CH5/X32_OUT
33	NC
34	NC
35	NC
36	NC
37	PF.3/EBI_nCS0/UART0_TXD/I2C0_SCL/XT1_IN/BPWM1_CH0
38	PF.2/EBI_nCS1/UART0_RXD/I2C0_SDA/QSPI0_CLK/XT1_OUT/BPWM1_CH1
39	NC

40	NC
41	PE.8/EBI_ADR10/USCI1_CTL1/UART2_TXD/PWM0_CH0/PWM0_BRAKE0
42	PE.9/EBI_ADR11/USCI1_CTL0/UART2_RXD/PWM0_CH1/PWM0_BRAKE1
43	PE.10/EBI_ADR12/USCI1_DAT0/PWM0_CH2/PWM1_BRAKE0
44	PE.11/EBI_ADR13/USCI1_DAT1/UART1_nCTS/PWM0_CH3/PWM1_BRAKE1
45	PE.12/EBI_ADR14/USCI1_CLK/UART1_nRTS/PWM0_CH4
46	PE.13/EBI_ADR15/I2C0_SCL/UART1_TXD/PWM0_CH5/PWM1_CH0/BPWM1_CH5
47	PC.8/EBI_ADR16/I2C0_SDA/UART1_RXD/PWM1_CH1/BPWM1_CH4
48	PC.7/EBI_AD9/UART0_nCTS/I2C1_SMBAL/PWM1_CH2/BPWM1_CH0/TM0/INT3
49	PC.6/EBI_AD8/UART0_nRTS/I2C1_SMBSUS/PWM1_CH3/BPWM1_CH1/TM1/INT2
50	PA.7/EBI_AD7/UART0_TXD/I2C1_SCL/PWM1_CH4/BPWM1_CH2/ACMP0_WLAT/TM2/INT1
51	PA.6/EBI_AD6/UART0_RXD/I2C1_SDA/PWM1_CH5/BPWM1_CH3/ACMP1_WLAT/TM3/INT0
52	V <sub>SS</sub>
53	V <sub>DD</sub>
54	PD.15/PSIO0_CH7/PWM0_CH5/TM3/INT1
55	PA.5/QSPI0_MISO1/UART0_nCTS/UART0_TXD/I2C0_SCL/BPWM0_CH5/PWM0_CH0
56	PA.4/QSPI0_MOSI1/SPI0_I2SMCLK/SC0_nCD/UART0_nRTS/UART0_RXD/I2C0_SDA/USCI2_CTL1/BPWM0_CH4/PWM0_CH1
57	PA.3/QSPI0_SS/SPI0_SS/SC0_PWR/I2C0_SMBAL/UART1_TXD/I2C1_SCL/PSIO0_CH4/USCI2_CTL0/BPWM0_CH3/PWM0_CH2/CLKO/PWM1_BRAKE1
58	PA.2/QSPI0_CLK/SPI0_CLK/SC0_RST/I2C0_SMBSUS/UART1_RXD/I2C1_SDA/PSIO0_CH5/USCI2_CLK/BPWM0_CH2/PWM0_CH3
59	PA.1/QSPI0_MISO0/SPI0_MISO/SC0_DAT/UART0_TXD/UART1_nCTS/PSIO0_CH6/USCI2_DAT0/BPWM0_CH1/PWM0_CH4
60	PA.0/QSPI0_MOSI0/SPI0_MOSI/SC0_CLK/UART0_RXD/UART1_nRTS/PSIO0_CH7/USCI2_DAT1/BPWM0_CH0/PWM0_CH5/DAC0_ST
61	V <sub>DDIO</sub>
62	PE.14/EBI_AD8/UART2_TXD/PSIO0_CH0
63	PE.15/EBI_AD9/UART2_RXD/PSIO0_CH1
64	nRESET <b>Note:</b> It is recommended to use 10 kΩ pull-up resistor and 10 uF capacitor on nRESET pin.
65	PF.0/UART1_TXD/I2C1_SCL/UART0_TXD/BPWM1_CH0/ICE_DAT <b>Note:</b> It is recommended to use 100 kΩ pull-up resistor on ICE_DAT pin.
66	PF.1/UART1_RXD/I2C1_SDA/UART0_RXD/BPWM1_CH1/ICE_CLK <b>Note:</b> It is recommended to use 100 kΩ pull-up resistor on ICE_CLK pin.
67	PD.9/EBI_AD7/UART2_nCTS/PSIO0_CH2
68	PD.8/EBI_AD6/UART2_nRTS/PSIO0_CH3
69	PC.5/EBI_AD5/QSPI0_MISO1/UART2_TXD/I2C1_SCL/PWM1_CH0/PSIO0_CH0
70	PC.4/EBI_AD4/QSPI0_MOSI1/UART2_RXD/I2C1_SDA/PWM1_CH1/USCI2_CTL1/PSIO0_CH1

71	PC.3/EBI_AD3/QSPI0_SS/UART2_nRTS/I2C0_SMBAL/PWM1_CH2/USCI2_CTL0/PSIO0_CH2
72	PC.2/EBI_AD2/QSPI0_CLK/UART2_nCTS/I2C0_SMBUS/PWM1_CH3/USCI2_CLK/PSIO0_CH3
73	PC.1/EBI_AD1/QSPI0_MISO0/UART2_TXD/I2C0_SCL/PWM1_CH4/USCI2_DAT0/ACMP0_O
74	PC.0/EBI_AD0/QSPI0_MOSI0/UART2_RXD/I2C0_SDA/PWM1_CH5/USCI2_DAT1/ACMP1_O
75	V <sub>SS</sub>
76	V <sub>DD</sub>
77	NC
78	NC
79	NC
80	NC
81	NC
82	NC
83	NC
84	PD.7/UART1_TXD/I2C0_SCL/USCI1_CLK/PSIO0_CH4
85	PD.6/UART1_RXD/I2C0_SDA/USCI1_DAT1/PSIO0_CH5
86	PD.5/I2C1_SCL/USCI1_DAT0/PSIO0_CH6
87	PD.4/USCI0_CTL0/I2C1_SDA/USCI1_CTL1/PSIO0_CH7
88	PD.3/EBI_AD10/USCI0_CTL1/SPI0_SS/USCI1_CTL0/UART0_TXD
89	PD.2/EBI_AD11/USCI0_DAT1/SPI0_CLK/UART0_RXD
90	PD.1/EBI_AD12/USCI0_DAT0/SPI0_MISO
91	PD.0/EBI_AD13/USCI0_CLK/SPI0_MOSI/TM2
92	PD.13/EBI_AD10/SPI0_I2SMCLK/USCI2_CTL0
93	PA.12/I2C1_SCL/USCI2_DAT1/PSIO0_CH4/BPWM1_CH2
94	PA.13/I2C1_SDA/USCI2_DAT0/PSIO0_CH5/BPWM1_CH3
95	PA.14/UART0_TXD/USCI2_CLK/PSIO0_CH6/BPWM1_CH4
96	PA.15/UART0_RXD/USCI2_CTL1/PSIO0_CH7/BPWM1_CH5
97	PE.7/PSIO0_CH0/PWM0_CH0/BPWM0_CH5
98	PE.6/SC0_nCD/USCI0_CTL0/PSIO0_CH1/PWM0_CH1/BPWM0_CH4
99	PE.5/EBI_nRD/SC0_PWR/USCI0_CTL1/PSIO0_CH2/PWM0_CH2/BPWM0_CH3
100	PE.4/EBI_nWR/SC0_RST/USCI0_DAT1/PSIO0_CH3/PWM0_CH3/BPWM0_CH2
101	PE.3/EBI_MCLK/SC0_DAT/USCI0_DAT0/PWM0_CH4/BPWM0_CH1
102	PE.2/EBI_ALE/SC0_CLK/USCI0_CLK/USCI2_CTL0/PWM0_CH5/BPWM0_CH0
103	NC
104	NC
105	PE.1/EBI_AD10/QSPI0_MISO0/I2C1_SCL/USCI2_DAT1
106	PE.0/EBI_AD11/QSPI0_MOSI0/I2C1_SDA/USCI2_DAT0

107	NC
108	NC
109	NC
110	NC
111	NC
112	V <sub>SS</sub>
113	LDO_CAP
114	V <sub>DD</sub>
115	PC.14/EBI_AD11/SPI0_I2SMCLK/USCI0_CTL0/QSPI0_CLK/USCI2_CLK/TM1
116	PB.15/EADC0_CH15/EBI_AD12/SPI0_SS/USCI0_CTL1/UART0_nCTS/PSIO0_CH0/PWM1_CH0/TM0_EXT/PWM0_BRAKE1
117	PB.14/EADC0_CH14/EBI_AD13/SPI0_CLK/USCI0_DAT1/UART0_nRTS/PSIO0_CH1/PWM1_CH1/TM1_EXT/CLKO
118	PB.13/EADC0_CH13/ACMP0_P3/ACMP1_P3/EBI_AD14/SPI0_MISO/USCI0_DAT0/UART0_TXD/PSIO0_CH2/PWM1_CH2/TM2_EXT
119	PB.12/EADC0_CH12/DAC0_OUT/ACMP0_P2/ACMP1_P2/EBI_AD15/SPI0_MOSI/USCI0_CLK/UART0_RXD/PSIO0_CH3/PWM1_CH3/TM3_EXT
120	AV <sub>DD</sub>
121	V <sub>REF</sub>
122	AV <sub>SS</sub>
123	PB.11/EADC0_CH11/EBI_ADR16/UART0_nCTS/I2C1_SCL/SPI0_I2SMCLK/BPWM1_CH0
124	PB.10/EADC0_CH10/EBI_ADR17/USCI1_CTL0/UART0_nRTS/I2C1_SDA/BPWM1_CH1
125	PB.9/EADC0_CH9/EBI_ADR18/USCI1_CTL1/UART0_TXD/UART1_nCTS/I2C1_SMBAL/BPWM1_CH2
126	PB.8/EADC0_CH8/EBI_ADR19/USCI1_CLK/UART0_RXD/UART1_nRTS/I2C1_SMBSUS/BPWM1_CH3
127	PB.7/EADC0_CH7/EBI_nWRL/USCI1_DAT0/UART1_TXD/EBI_nCS0/BPWM1_CH4/PWM1_BRAKE0/PWM1_CH4/INT5/ACMP0_O
128	PB.6/EADC0_CH6/EBI_nWRH/USCI1_DAT1/UART1_RXD/EBI_nCS1/BPWM1_CH5/PWM1_BRAKE1/PWM1_CH5/INT4/ACMP1_O

Table 4.1-12 M251KG6AE Multi-function Pin Table

### 4.1.3 M252 Series Pin Diagram

#### 4.1.3.1 M252 Series TSSOP 20-Pin Diagram

Corresponding Part Number: M252FC2AE

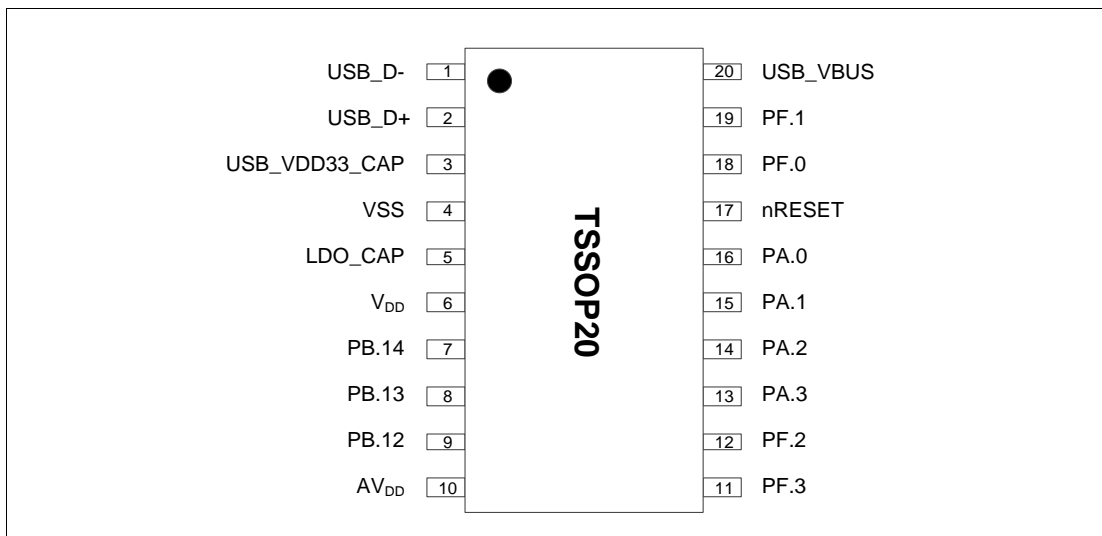

Figure 4.1-20 M252 Series TSSOP 20-pin Diagram

#### 4.1.3.2 M252 Series TSSOP 28-Pin Diagram

Corresponding Part Number: M252EC2AE

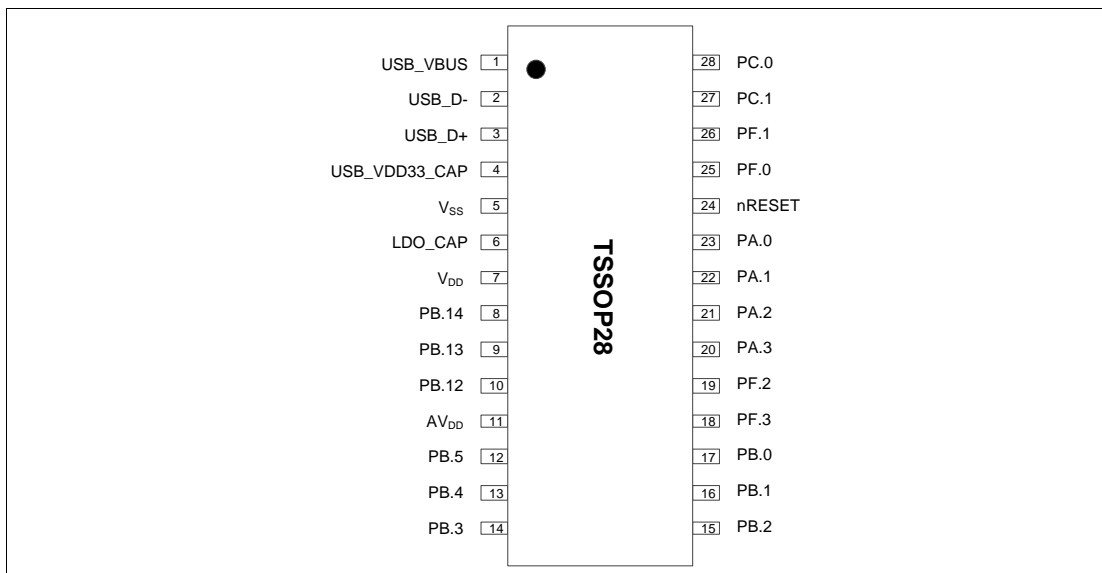

Figure 4.1-21 M252 Series TSSOP 28-pin Diagram

4.1.3.3 M252 Series QFN 33-Pin Diagram

Corresponding Part Number: M252ZD2AE, M252ZC2AE

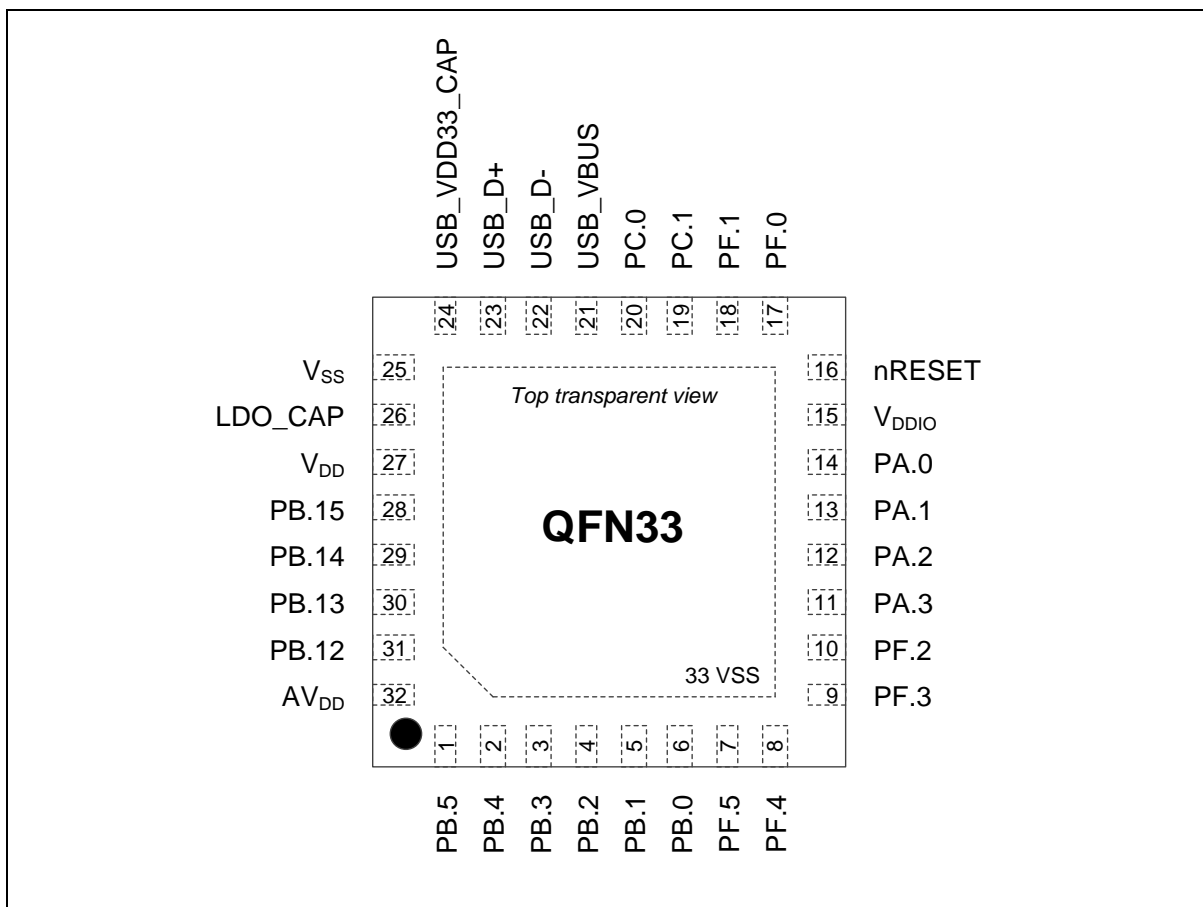

Figure 4.1-22 M252 Series QFN 33-pin Diagram

4.1.3.4 M252 Series LQFP 48-Pin Diagram

Corresponding Part Number: M252LG6AE, M252LE3AE, M252LD2AE, M252LC2AE

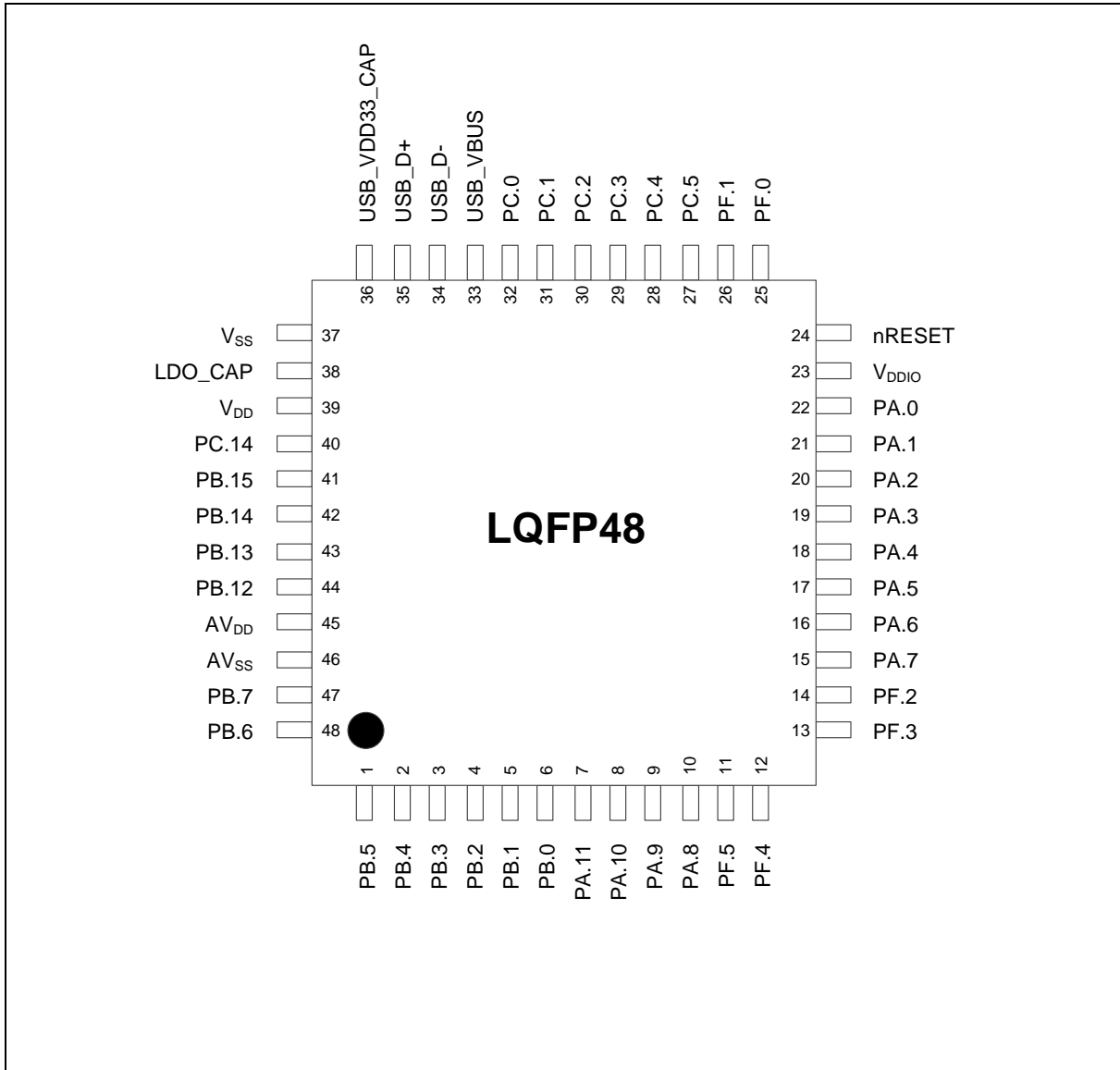

Figure 4.1-23 M252 Series LQFP 48-pin Diagram

4.1.3.5 M252 Series LQFP 64-Pin Diagram

Corresponding Part Number: M252SD2AE, M252SC2AE

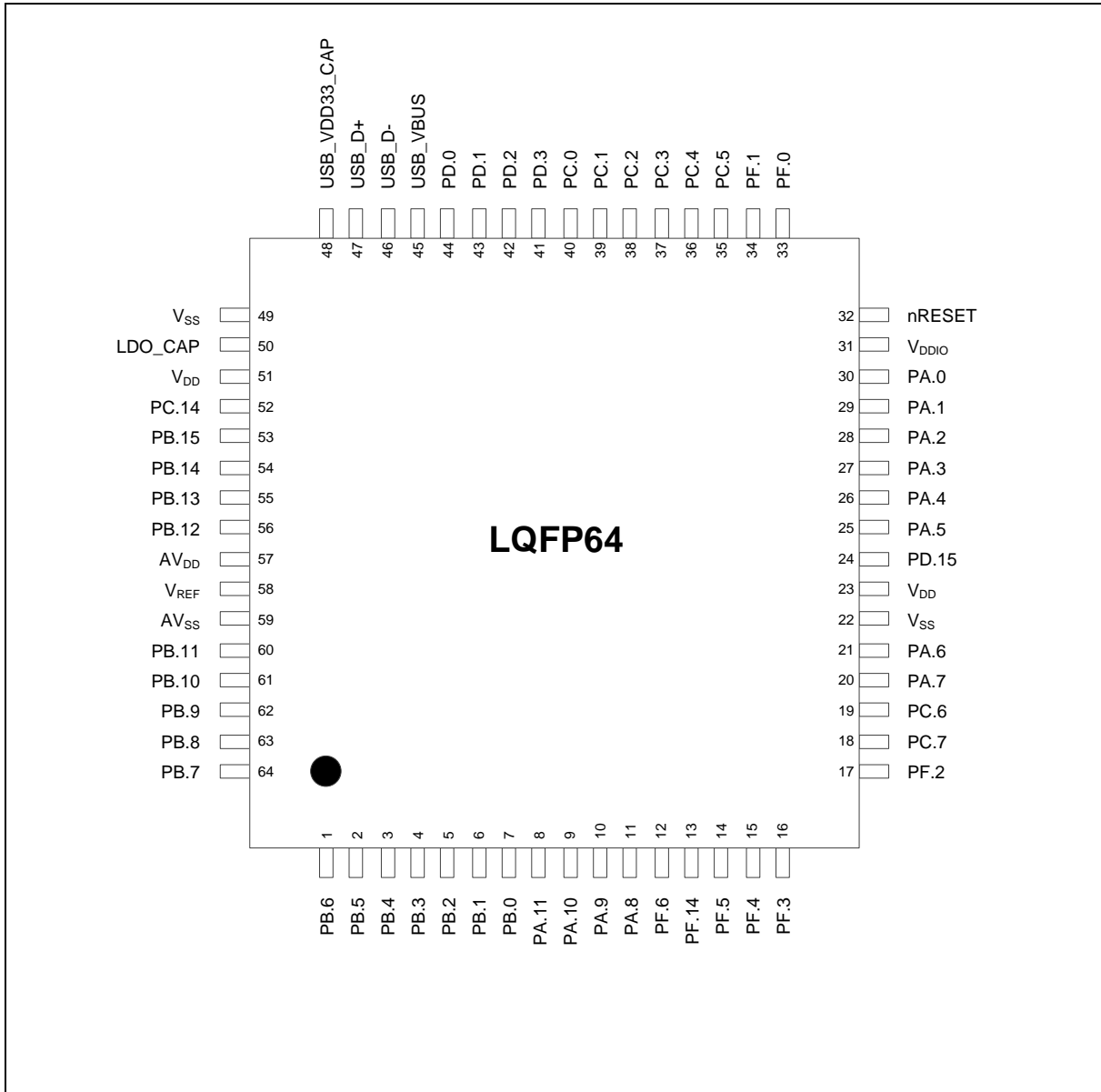

Figure 4.1-24 M252 Series LQFP 64-pin Diagram without V<sub>BAT</sub>

Corresponding Part Number: M252SG6AE, M252SE3AE

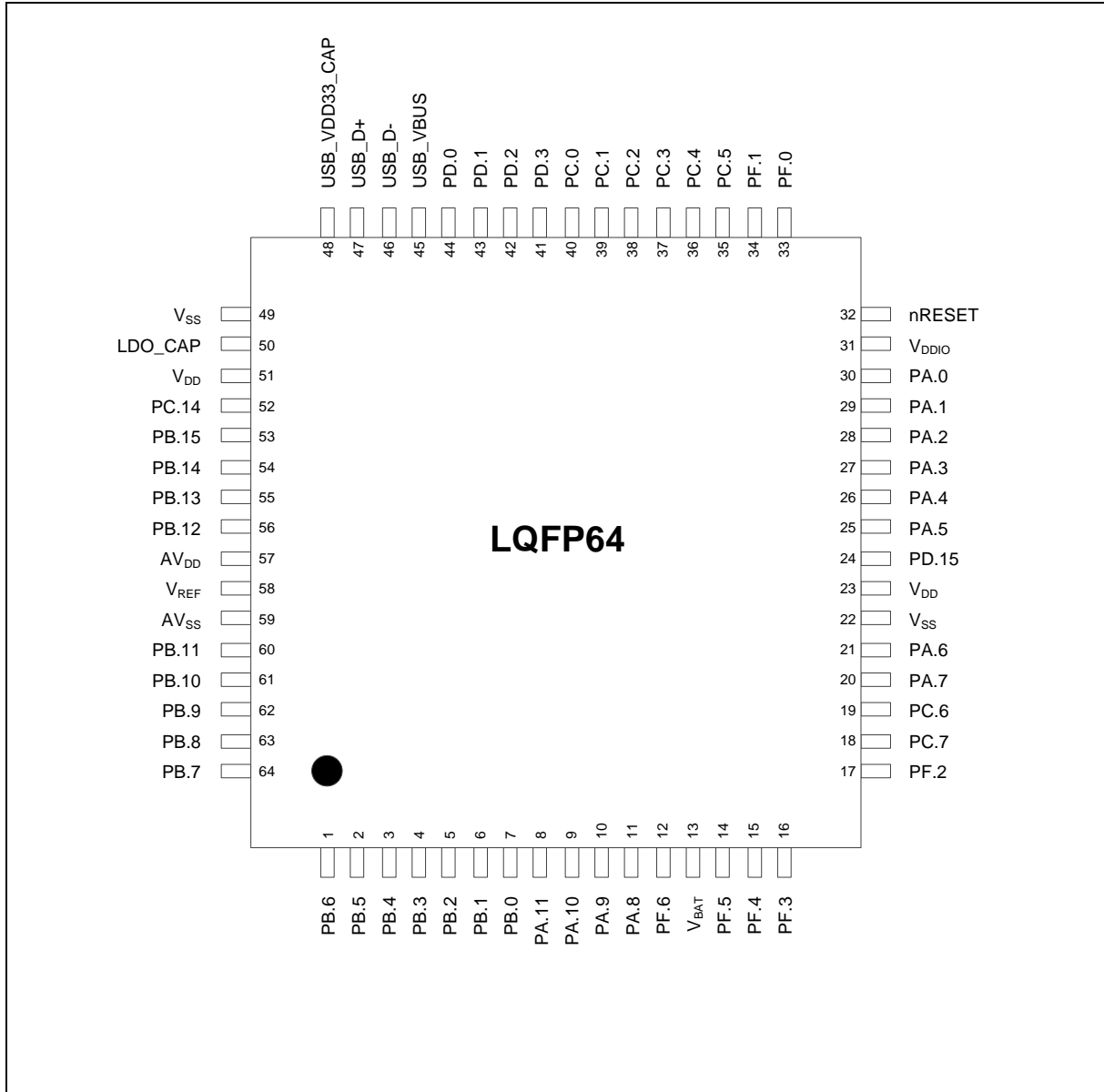

Figure 4.1-25 M252 Series LQFP 64-pin Diagram with V<sub>BAT</sub>

4.1.3.6 M252 Series LQFP 128-Pin Diagram

Corresponding Part Number: M252KG6AE, M252KE3AE

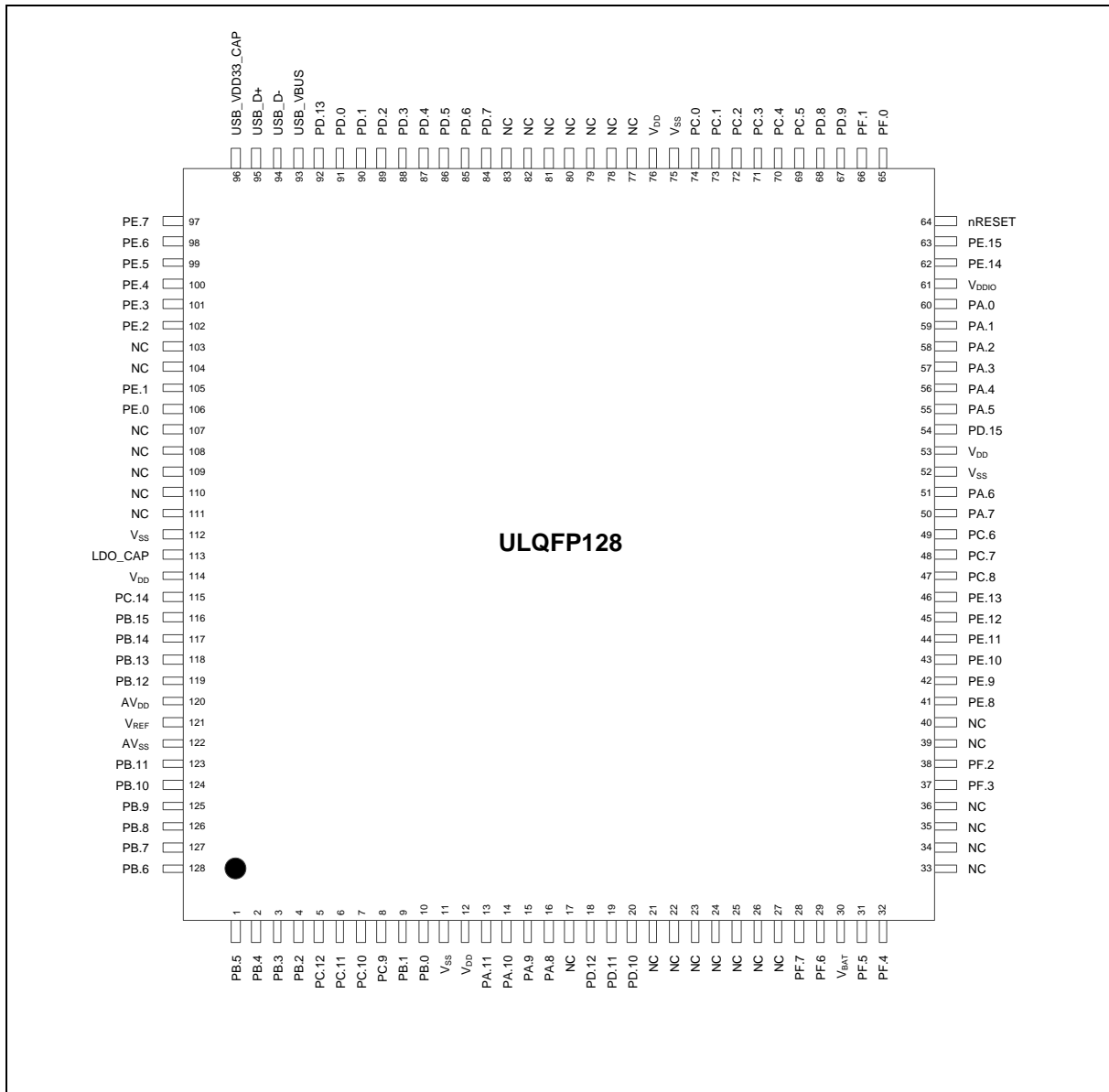

Figure 4.1-26 M252 Series LQFP 128-pin Diagram

### 4.1.4 M252 Series Function Pin Diagram

#### 4.1.4.1 M252 Series TSSOP 20-Pin Multi-function Pin Diagram

Corresponding Part Number: M252FC2AE

#### M252FC2AE

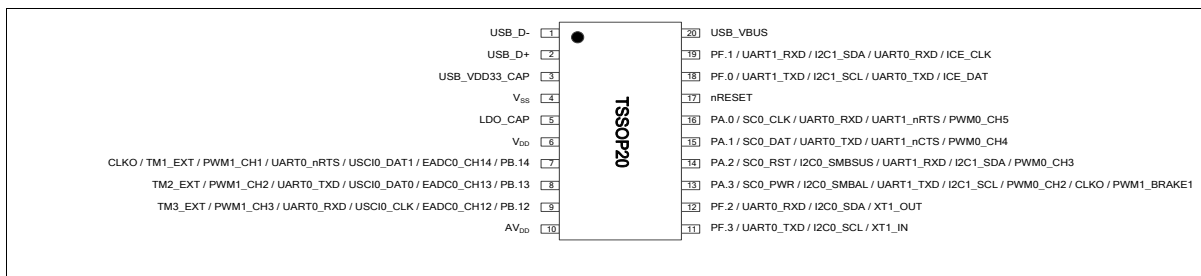

Figure 4.1-27 M252FC2AE Function Pin Diagram

Pin	M252FC2AE Pin Function
1	USB_D-
2	USB_D+
3	USB_VDD33_CAP
4	V <sub>SS</sub>
5	LDO_CAP
6	V <sub>DD</sub>
7	PB.14/EADC0_CH14/USCIO_DAT1/UART0_nRTS/PWM1_CH1/TM1_EXT/CLKO
8	PB.13/EADC0_CH13/USCIO_DAT0/UART0_TXD/PWM1_CH2/TM2_EXT
9	PB.12/EADC0_CH12/USCIO_CLK/UART0_RXD/PWM1_CH3/TM3_EXT
10	AV <sub>DD</sub>
11	PF.3/UART0_TXD/I2C0_SCL/XT1_IN
12	PF.2/UART0_RXD/I2C0_SDA/QSPI0_CLK/XT1_OUT
13	PA.3/QSPI0_SS/SC0_PWR/I2C0_SMBAL/UART1_TXD/I2C1_SCL/PWM0_CH2/CLKO/PWM1_BRAKE1
14	PA.2/QSPI0_CLK/SC0_RST/I2C0_SMBSUS/UART1_RXD/I2C1_SDA/PWM0_CH3
15	PA.1/QSPI0_MISO0/SC0_DAT/UART0_TXD/UART1_nCTS/PWM0_CH4
16	PA.0/QSPI0_MOSI0/SC0_CLK/UART0_RXD/UART1_nRTS/PWM0_CH5
17	nRESET <b>Note:</b> It is recommended to use 10 kΩ pull-up resistor and 10 uF capacitor on nRESET pin.
18	PF.0/UART1_TXD/I2C1_SCL/UART0_TXD/ICE_DAT <b>Note:</b> It is recommended to use 100 kΩ pull-up resistor on ICE_DAT pin.
19	PF.1/UART1_RXD/I2C1_SDA/UART0_RXD/ICE_CLK <b>Note:</b> It is recommended to use 100 kΩ pull-up resistor on ICE_CLK pin.
20	USB_VBUS

Table 4.1-13 M252FC2AE Multi-function Pin Table

4.1.4.2 M252 Series TSSOP 28-Pin Multi-function Pin Diagram

Corresponding Part Number: M252EC2AE

**M252EC2AE**

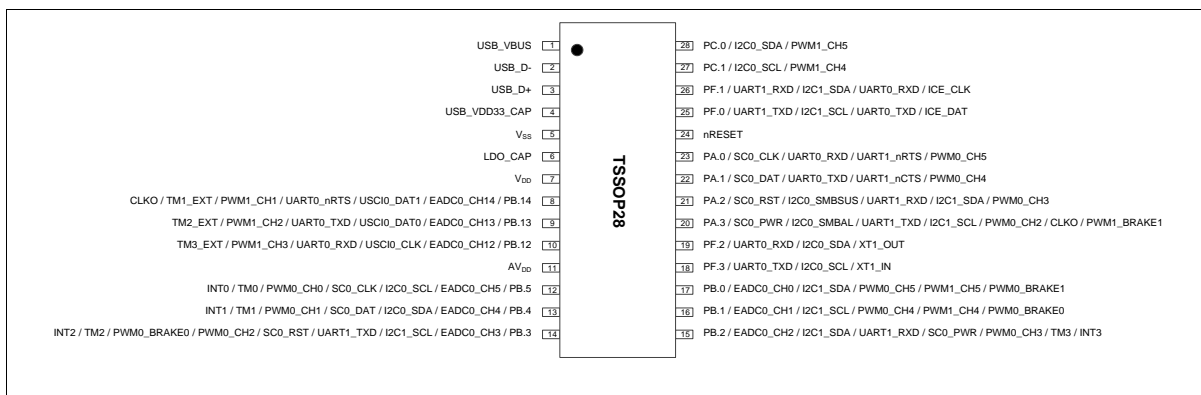

Figure 4.1-28 M252EC2AE Function Pin Diagram

Pin	M252EC2AE Pin Function
1	USB_VBUS
2	USB_D-
3	USB_D+
4	USB_VDD33_CAP
5	V <sub>SS</sub>
6	LDO_CAP
7	V <sub>DD</sub>
8	PB.14/EADC0_CH14/USCIO_DAT1/UART0_nRTS/PWM1_CH1/TM1_EXT/CLK0
9	PB.13/EADC0_CH13/USCIO_DAT0/UART0_TXD/PWM1_CH2/TM2_EXT
10	PB.12/EADC0_CH12/USCIO_CLK/UART0_RXD/PWM1_CH3/TM3_EXT
11	AV <sub>DD</sub>
12	PB.5/EADC0_CH5/I2C0_SCL/SC0_CLK/PWM0_CH0/TM0/INT0
13	PB.4/EADC0_CH4/I2C0_SDA/SC0_DAT/PWM0_CH1/TM1/INT1
14	PB.3/EADC0_CH3/I2C1_SCL/UART1_TXD/SC0_RST/PWM0_CH2/PWM0_BRAKE0/TM2/INT2
15	PB.2/EADC0_CH2/I2C1_SDA/UART1_RXD/SC0_PWR/PWM0_CH3/TM3/INT3
16	PB.1/EADC0_CH1/I2C1_SCL/QSPI0_MISO1/PWM0_CH4/PWM1_CH4/PWM0_BRAKE0
17	PB.0/EADC0_CH0/I2C1_SDA/QSPI0_MOSI1/PWM0_CH5/PWM1_CH5/PWM0_BRAKE1
18	PF.3/UART0_TXD/I2C0_SCL/XT1_IN
19	PF.2/UART0_RXD/I2C0_SDA/QSPI0_CLK/XT1_OUT

20	PA.3/QSPI0_SS/SC0_PWR/I2C0_SMBAL/UART1_TXD/I2C1_SCL/PWM0_CH2/CLKO/PWM1_BRAKE1
21	PA.2/QSPI0_CLK/SC0_RST/I2C0_SMBSUS/UART1_RXD/I2C1_SDA/PWM0_CH3
22	PA.1/QSPI0_MISO0/SC0_DAT/UART0_TXD/UART1_nCTS/PWM0_CH4
23	PA.0/QSPI0_MOSI0/SC0_CLK/UART0_RXD/UART1_nRTS/PWM0_CH5
24	nRESET <b>Note:</b> It is recommended to use 10 kΩ pull-up resistor and 10 uF capacitor on nRESET pin.
25	PF.0/UART1_TXD/I2C1_SCL/UART0_TXD/ICE_DAT <b>Note:</b> It is recommended to use 100 kΩ pull-up resistor on ICE_DAT pin.
26	PF.1/UART1_RXD/I2C1_SDA/UART0_RXD/ICE_CLK <b>Note:</b> It is recommended to use 100 kΩ pull-up resistor on ICE_CLK pin.
27	PC.1/QSPI0_MISO0/I2C0_SCL/PWM1_CH4
28	PC.0/QSPI0_MOSI0/I2C0_SDA/PWM1_CH5

Table 4.1-14 M252EC2AE Multi-function Pin Table

4.1.4.3 M252 Series QFN 33-Pin Multi-function Pin Diagram

Corresponding Part Number: M252ZC2AE, M252ZD2AE

**M252ZC2AE**

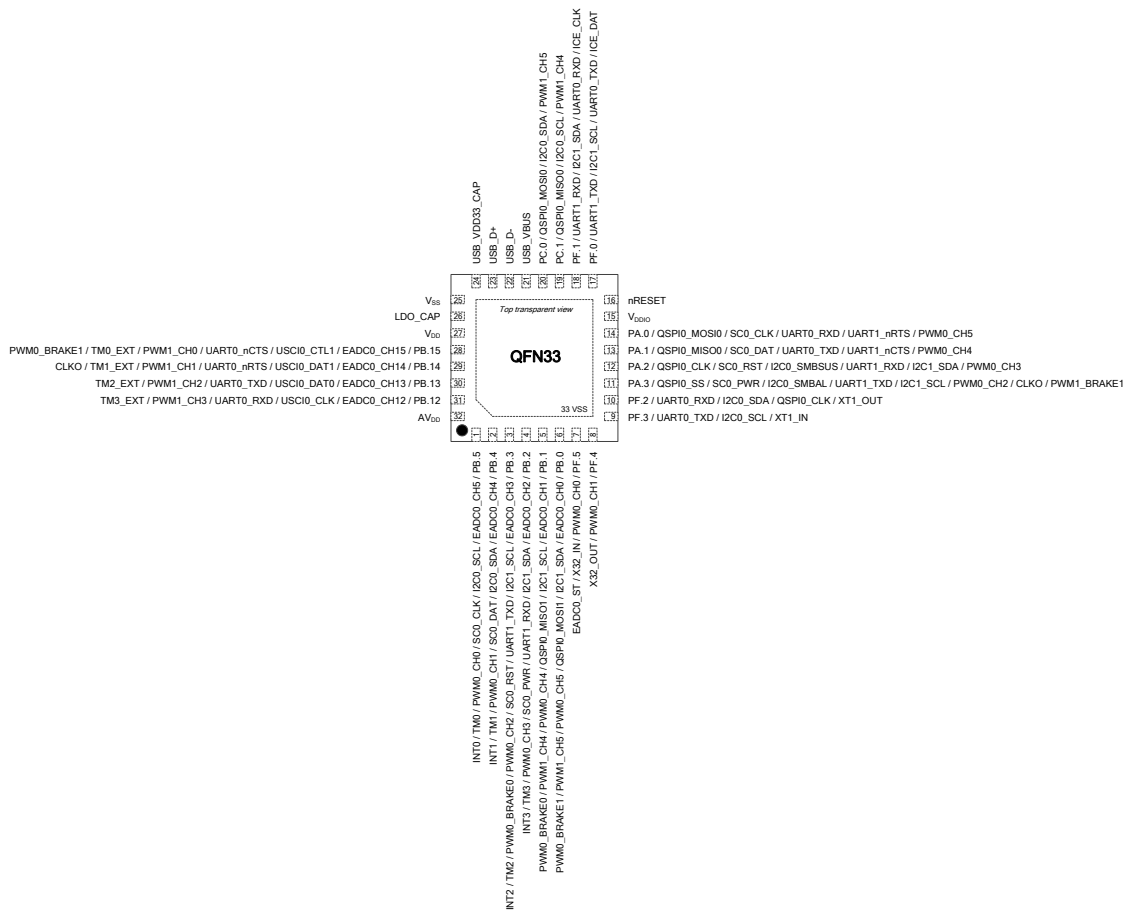

Figure 4.1-29 M252ZC2AE Function Pin Diagram

Pin	M252ZC2AE Pin Function
1	PB.5/EADC0_CH5/I2C0_SCL/SC0_CLK/PWM0_CH0/TM0/INT0
2	PB.4/EADC0_CH4/I2C0_SDA/SC0_DAT/PWM0_CH1/TM1/INT1
3	PB.3/EADC0_CH3/I2C1_SCL/UART1_TXD/SC0_RST/PWM0_CH2/PWM0_BRAKE0/TM2/INT2
4	PB.2/EADC0_CH2/I2C1_SDA/UART1_RXD/SC0_PWR/PWM0_CH3/TM3/INT3

5	PB.1/EADC0_CH1/I2C1_SCL/QSPI0_MISO1/PWM0_CH4/PWM1_CH4/PWM0_BRAKE0
6	PB.0/EADC0_CH0/I2C1_SDA/QSPI0_MOSI1/PWM0_CH5/PWM1_CH5/PWM0_BRAKE1
7	PF.5/PWM0_CH0/X32_IN/EADC0_ST
8	PF.4/PWM0_CH1/X32_OUT
9	PF.3/UART0_TXD/I2C0_SCL/XT1_IN
10	PF.2/UART0_RXD/I2C0_SDA/QSPI0_CLK/XT1_OUT
11	PA.3/QSPI0_SS/SC0_PWR/I2C0_SMBAL/UART1_TXD/I2C1_SCL/PWM0_CH2/CLKO/PWM1_BRAKE1
12	PA.2/QSPI0_CLK/SC0_RST/I2C0_SMBSUS/UART1_RXD/I2C1_SDA/PWM0_CH3
13	PA.1/QSPI0_MISO0/SC0_DAT/UART0_TXD/UART1_nCTS/PWM0_CH4
14	PA.0/QSPI0_MOSI0/SC0_CLK/UART0_RXD/UART1_nRTS/PWM0_CH5
15	V <sub>DDIO</sub>
16	nRESET <b>Note:</b> It is recommended to use 10 kΩ pull-up resistor and 10 uF capacitor on nRESET pin.
17	PF.0/UART1_TXD/I2C1_SCL/UART0_TXD/ICE_DAT <b>Note:</b> It is recommended to use 100 kΩ pull-up resistor on ICE_DAT pin.
18	PF.1/UART1_RXD/I2C1_SDA/UART0_RXD/ICE_CLK <b>Note:</b> It is recommended to use 100 kΩ pull-up resistor on ICE_CLK pin.
19	PC.1/QSPI0_MISO0/I2C0_SCL/PWM1_CH4
20	PC.0/QSPI0_MOSI0/I2C0_SDA/PWM1_CH5
21	USB_VBUS
22	USB_D-
23	USB_D+
24	USB_VDD33_CAP
25	V <sub>SS</sub>
26	LDO_CAP
27	V <sub>DD</sub>
28	PB.15/EADC0_CH15/USCI0_CTL1/UART0_nCTS/PWM1_CH0/TM0_EXT/PWM0_BRAKE1
29	PB.14/EADC0_CH14/USCI0_DAT1/UART0_nRTS/PWM1_CH1/TM1_EXT/CLKO
30	PB.13/EADC0_CH13/USCI0_DAT0/UART0_TXD/PWM1_CH2/TM2_EXT
31	PB.12/EADC0_CH12/USCI0_CLK/UART0_RXD/PWM1_CH3/TM3_EXT
32	AV <sub>DD</sub>

Table 4.1-15 M252ZC2AE Multi-function Pin Table

M252ZD2AE

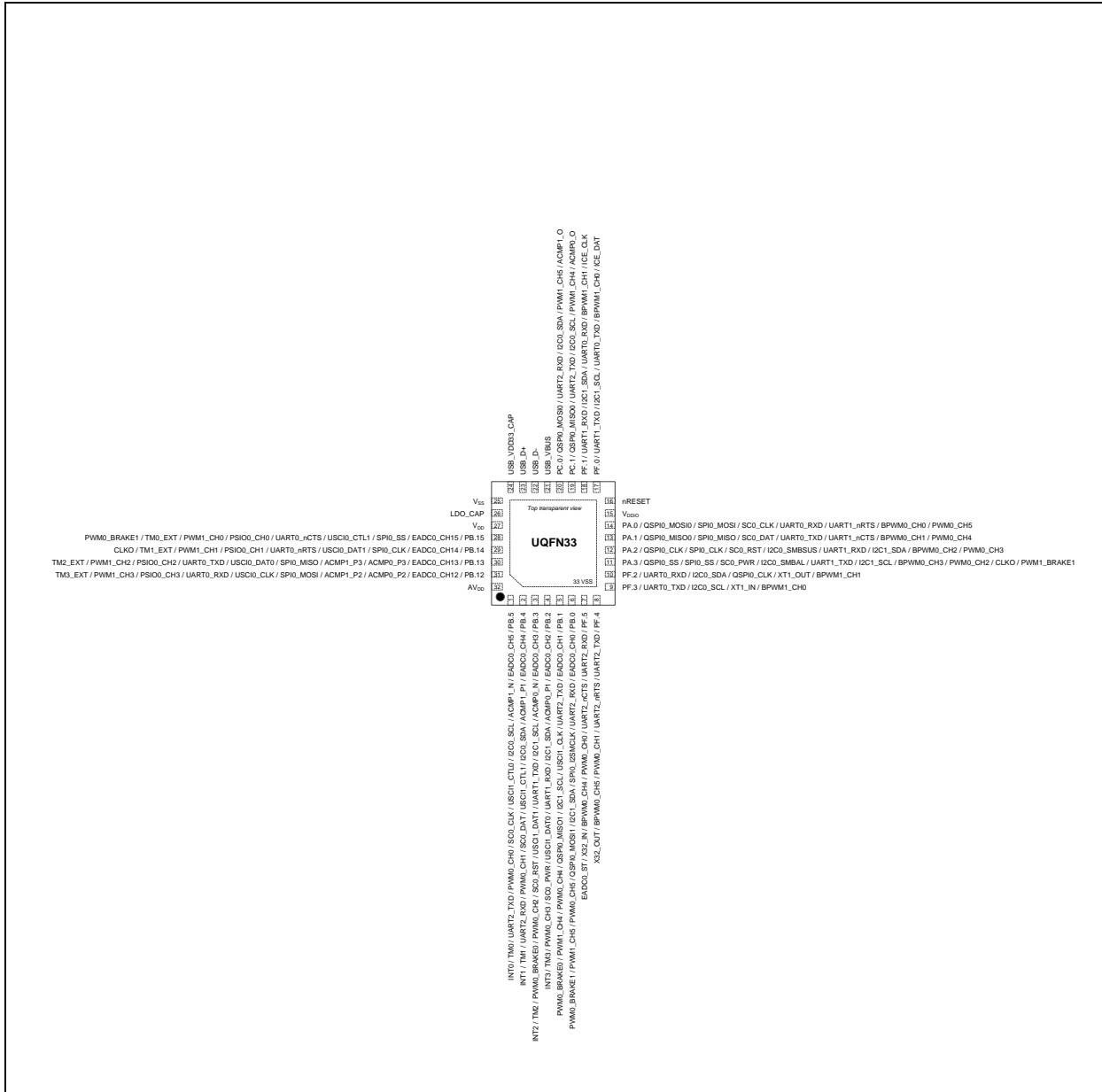

Figure 4.1-30 M252ZD2A Function Pin Diagram

Pin	M252ZD2AE Pin Function
1	PB.5/EADC0_CH5/ACMP1_N/I2C0_SCL/USCI1_CTL0/SC0_CLK/PWM0_CH0/UART2_TXD/TM0/INT0
2	PB.4/EADC0_CH4/ACMP1_P1/I2C0_SDA/USCI1_CTL1/SC0_DAT/PWM0_CH1/UART2_RXD/TM1/INT1
3	PB.3/EADC0_CH3/ACMP0_N/I2C1_SCL/UART1_TXD/USCI1_DAT1/SC0_RST/PWM0_CH2/PWM0_BRAKE0/TM2/INT2
4	PB.2/EADC0_CH2/ACMP0_P1/I2C1_SDA/UART1_RXD/USCI1_DAT0/SC0_PWR/PWM0_CH3/TM3/INT3
5	PB.1/EADC0_CH1/UART2_TXD/USCI1_CLK/I2C1_SCL/QSPI0_MISO1/PWM0_CH4/PWM1_CH4/PWM0_BRAKE0
6	PB.0/EADC0_CH0/UART2_RXD/SPI0_I2SMCLK/I2C1_SDA/QSPI0_MOS11/PWM0_CH5/PWM1_CH5/PWM0_BRAKE1

7	PF.5/UART2_RXD/UART2_nCTS/PWM0_CH0/BPWM0_CH4/X32_IN/EADC0_ST
8	PF.4/UART2_TXD/UART2_nRTS/PWM0_CH1/BPWM0_CH5/X32_OUT
9	PF.3/UART0_TXD/I2C0_SCL/XT1_IN/BPWM1_CH0
10	PF.2/UART0_RXD/I2C0_SDA/QSPI0_CLK/XT1_OUT/BPWM1_CH1
11	PA.3/QSPI0_SS/SPI0_SS/SC0_PWR/I2C0_SMBAL/UART1_TXD/I2C1_SCL/BPWM0_CH3/PWM0_CH2/CLKO/PWM1_BRAKE1
12	PA.2/QSPI0_CLK/SPI0_CLK/SC0_RST/I2C0_SMBUS/UART1_RXD/I2C1_SDA/BPWM0_CH2/PWM0_CH3
13	PA.1/QSPI0_MISO0/SPI0_MISO/SC0_DAT/UART0_TXD/UART1_nCTS/BPWM0_CH1/PWM0_CH4
14	PA.0/QSPI0_MOSI0/SPI0_MOSI/SC0_CLK/UART0_RXD/UART1_nRTS/BPWM0_CH0/PWM0_CH5
15	V <sub>DDIO</sub>
16	nRESET <b>Note:</b> It is recommended to use 10 kΩ pull-up resistor and 10 uF capacitor on nRESET pin.
17	PF.0/UART1_TXD/I2C1_SCL/UART0_TXD/BPWM1_CH0/ICE_DAT <b>Note:</b> It is recommended to use 100 kΩ pull-up resistor on ICE_DAT pin.
18	PF.1/UART1_RXD/I2C1_SDA/UART0_RXD/BPWM1_CH1/ICE_CLK <b>Note:</b> It is recommended to use 100 kΩ pull-up resistor on ICE_CLK pin.
19	PC.1/QSPI0_MISO0/UART2_TXD/I2C0_SCL/PWM1_CH4/ACMP0_O
20	PC.0/QSPI0_MOSI0/UART2_RXD/I2C0_SDA/PWM1_CH5/ACMP1_O
21	USB_VBUS
22	USB_D-
23	USB_D+
24	USB_VDD33_CAP
25	V <sub>SS</sub>
26	LDO_CAP
27	V <sub>DD</sub>
28	PB.15/EADC0_CH15/SPI0_SS/USCI0_CTL1/UART0_nCTS/PSIO0_CH0/PWM1_CH0/TM0_EXT/PWM0_BRAKE1
29	PB.14/EADC0_CH14/SPI0_CLK/USCI0_DAT1/UART0_nRTS/PSIO0_CH1/PWM1_CH1/TM1_EXT/CLKO
30	PB.13/EADC0_CH13/ACMP0_P3/ACMP1_P3/SPI0_MISO/USCI0_DAT0/UART0_TXD/PSIO0_CH2/PWM1_CH2/TM2_EXT
31	PB.12/EADC0_CH12/ACMP0_P2/ACMP1_P2/SPI0_MOSI/USCI0_CLK/UART0_RXD/PSIO0_CH3/PWM1_CH3/TM3_EXT
32	AV <sub>DD</sub>

Table 4.1-16 M252ZD2AE Multi-function Pin Table

4.1.4.4 M252 Series LQFP 48-Pin Multi-function Pin Diagram

Corresponding Part Number: M252LC2AE, M252LD2AE, M252LE3AE, M252LG6AE

M252LC2AE / M252LD2AE

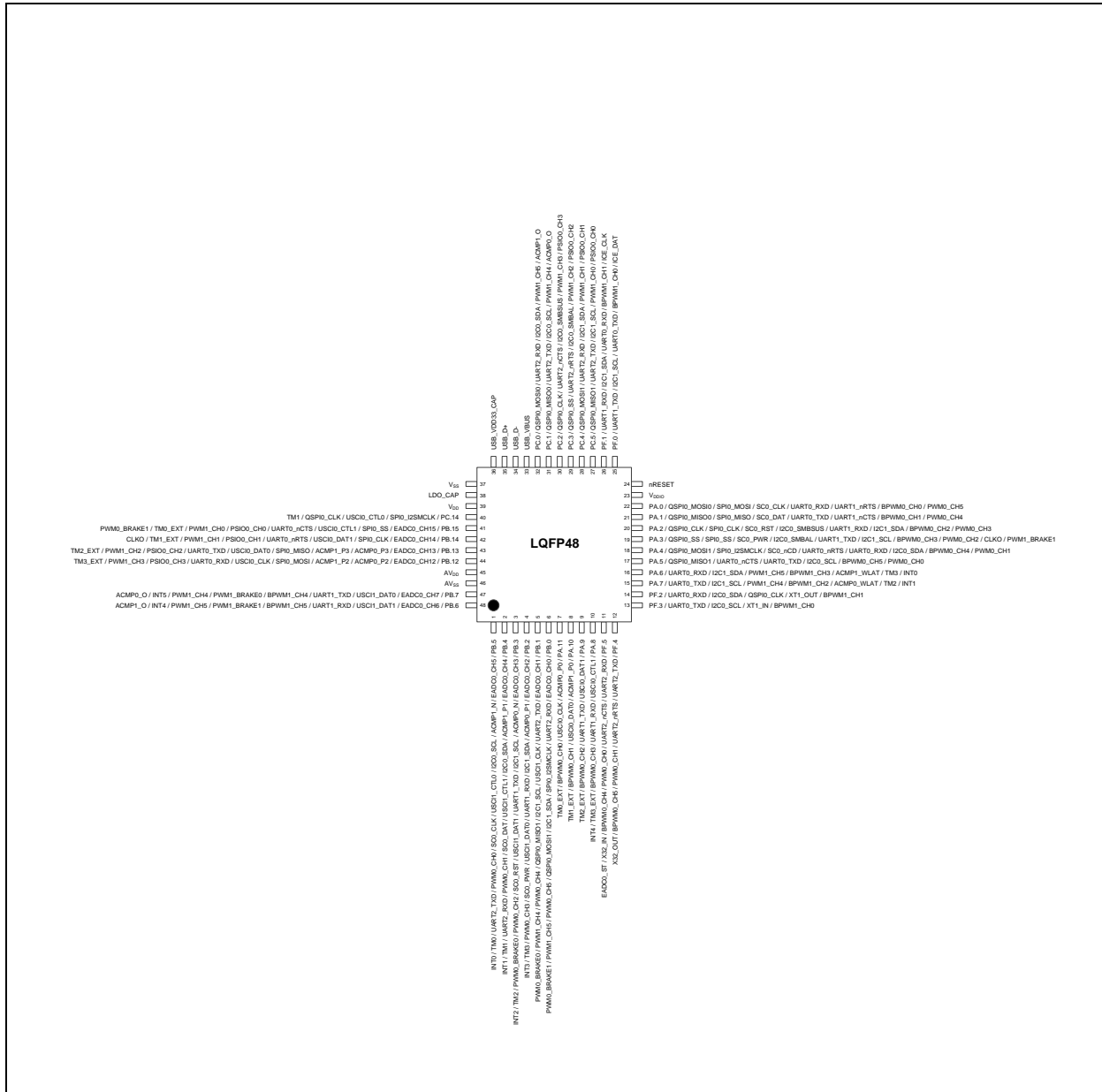

Figure 4.1-31 M252LC2AE/M252LD2AE Function Pin Diagram

Pin	M252LC2AE/M252LD2AE Pin Function
1	PB.5/EADC0_CH5/ACMP1_N/I2C0_SCL/USCI1_CTL0/SC0_CLK/PWM0_CH0/UART2_TXD/TM0/INT0
2	PB.4/EADC0_CH4/ACMP1_P1/I2C0_SDA/USCI1_CTL1/SC0_DAT/PWM0_CH1/UART2_RXD/TM1/INT1
3	PB.3/EADC0_CH3/ACMP0_N/I2C1_SCL/UART1_TXD/USCI1_DAT1/SC0_RST/PWM0_CH2/PWM0_BRAKE0/TM2/INT2
4	PB.2/EADC0_CH2/ACMP0_P1/I2C1_SDA/UART1_RXD/USCI1_DAT0/SC0_PWR/PWM0_CH3/TM3/INT3

5	PB.1/EADC0_CH1/UART2_TXD/USCI1_CLK/I2C1_SCL/QSPI0_MISO1/PWM0_CH4/PWM1_CH4/PWM0_BRAKE0
6	PB.0/EADC0_CH0/UART2_RXD/SPI0_I2SMCLK/I2C1_SDA/QSPI0_MOSI1/PWM0_CH5/PWM1_CH5/PWM0_BRAKE1
7	PA.11/ACMP0_P0/USCI0_CLK/BPWM0_CH0/TM0_EXT
8	PA.10/ACMP1_P0/USCI0_DAT0/BPWM0_CH1/TM1_EXT
9	PA.9/USCI0_DAT1/UART1_TXD/BPWM0_CH2/TM2_EXT
10	PA.8/USCI0_CTL1/UART1_RXD/BPWM0_CH3/TM3_EXT/INT4
11	PF.5/UART2_RXD/UART2_nCTS/PWM0_CH0/BPWM0_CH4/X32_IN/EADC0_ST
12	PF.4/UART2_TXD/UART2_nRTS/PWM0_CH1/BPWM0_CH5/X32_OUT
13	PF.3/UART0_TXD/I2C0_SCL/XT1_IN/BPWM1_CH0
14	PF.2/UART0_RXD/I2C0_SDA/QSPI0_CLK/XT1_OUT/BPWM1_CH1
15	PA.7/UART0_TXD/I2C1_SCL/PWM1_CH4/BPWM1_CH2/ACMP0_WLAT/TM2/INT1
16	PA.6/UART0_RXD/I2C1_SDA/PWM1_CH5/BPWM1_CH3/ACMP1_WLAT/TM3/INT0
17	PA.5/QSPI0_MISO1/UART0_nCTS/UART0_TXD/I2C0_SCL/BPWM0_CH5/PWM0_CH0
18	PA.4/QSPI0_MOSI1/SPI0_I2SMCLK/SC0_nCD/UART0_nRTS/UART0_RXD/I2C0_SDA/BPWM0_CH4/PWM0_CH1
19	PA.3/QSPI0_SS/SPI0_SS/SC0_PWR/I2C0_SMBAL/UART1_TXD/I2C1_SCL/BPWM0_CH3/PWM0_CH2/CLKO/PWM1_BRAKE1
20	PA.2/QSPI0_CLK/SPI0_CLK/SC0_RST/I2C0_SMBSUS/UART1_RXD/I2C1_SDA/BPWM0_CH2/PWM0_CH3
21	PA.1/QSPI0_MISO0/SPI0_MISO/SC0_DAT/UART0_TXD/UART1_nCTS/BPWM0_CH1/PWM0_CH4
22	PA.0/QSPI0_MOSI0/SPI0_MOSI/SC0_CLK/UART0_RXD/UART1_nRTS/BPWM0_CH0/PWM0_CH5
23	V <sub>DDIO</sub>
24	nRESET <b>Note:</b> It is recommended to use 10 kΩ pull-up resistor and 10 uF capacitor on nRESET pin.
25	PF.0/UART1_TXD/I2C1_SCL/UART0_TXD/BPWM1_CH0/ICE_DAT <b>Note:</b> It is recommended to use 100 kΩ pull-up resistor on ICE_DAT pin.
26	PF.1/UART1_RXD/I2C1_SDA/UART0_RXD/BPWM1_CH1/ICE_CLK <b>Note:</b> It is recommended to use 100 kΩ pull-up resistor on ICE_CLK pin.
27	PC.5/QSPI0_MISO1/UART2_TXD/I2C1_SCL/PWM1_CH0/PSIO0_CH0
28	PC.4/QSPI0_MOSI1/UART2_RXD/I2C1_SDA/PWM1_CH1/PSIO0_CH1
29	PC.3/QSPI0_SS/UART2_nRTS/I2C0_SMBAL/PWM1_CH2/PSIO0_CH2
30	PC.2/QSPI0_CLK/UART2_nCTS/I2C0_SMBSUS/PWM1_CH3/PSIO0_CH3
31	PC.1/QSPI0_MISO0/UART2_TXD/I2C0_SCL/PWM1_CH4/ACMP0_O
32	PC.0/QSPI0_MOSI0/UART2_RXD/I2C0_SDA/PWM1_CH5/ACMP1_O
33	USB_VBUS
34	USB_D-
35	USB_D+
36	USB_VDD33_CAP

37	V <sub>SS</sub>
38	LDO_CAP
39	V <sub>DD</sub>
40	PC.14/SPI0_I2SMCLK/USCI0_CTL0/QSPI0_CLK/TM1
41	PB.15/EADC0_CH15/SPI0_SS/USCI0_CTL1/UART0_nCTS/PSIO0_CH0/PWM1_CH0/TM0_EXT/PWM0_BRAKE1
42	PB.14/EADC0_CH14/SPI0_CLK/USCI0_DAT1/UART0_nRTS/PSIO0_CH1/PWM1_CH1/TM1_EXT/CLKO
43	PB.13/EADC0_CH13/ACMP0_P3/ACMP1_P3/SPI0_MISO/USCI0_DAT0/UART0_TXD/PSIO0_CH2/PWM1_CH2/TM2_EXT
44	PB.12/EADC0_CH12/ACMP0_P2/ACMP1_P2/SPI0_MOSI/USCI0_CLK/UART0_RXD/PSIO0_CH3/PWM1_CH3/TM3_EXT
45	AV <sub>DD</sub>
46	AV <sub>SS</sub>
47	PB.7/EADC0_CH7/USCI1_DAT0/UART1_TXD/BPWM1_CH4/PWM1_BRAKE0/PWM1_CH4/INT5/ACMP0_O
48	PB.6/EADC0_CH6/USCI1_DAT1/UART1_RXD/BPWM1_CH5/PWM1_BRAKE1/PWM1_CH5/INT4/ACMP1_O

Table 4.1-17 M252LC2AE/M252LD2AE Multi-function Pin Table

Corresponding Part Number: M252LE3AE

M252LE3AE

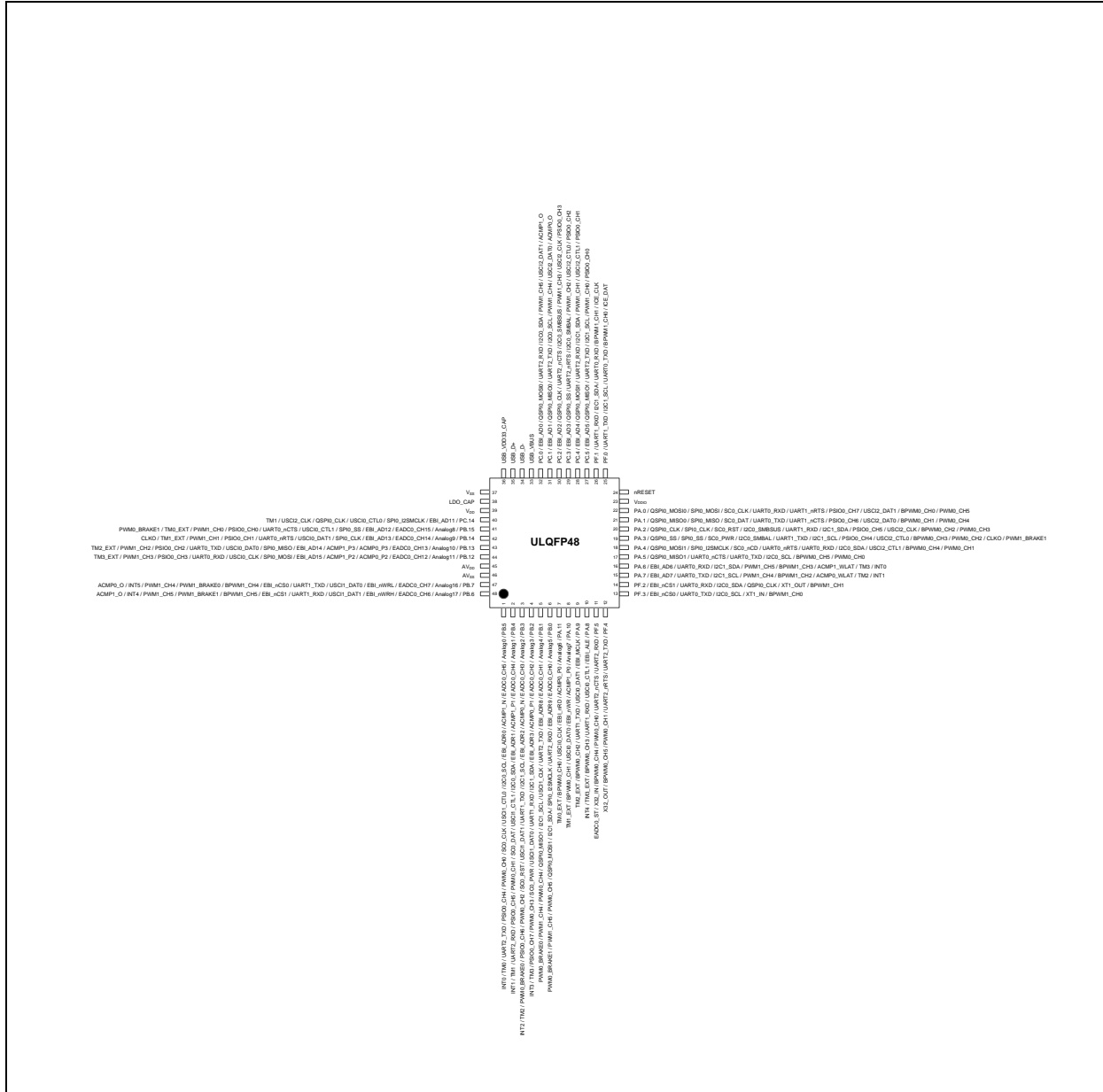

Figure 4.1-32 M252LE3AE Function Pin Diagram

Pin	M252LE3AE Pin Function
1	PB.5/EADC0_CH5/ACMP1_N/EBI_ADR0/I2C0_SCL/USCI1_CTL0/SC0_CLK/PWM0_CH0/PSIO0_CH4/UART2_TXD/TM0/INT0
2	PB.4/EADC0_CH4/ACMP1_P1/EBI_ADR1/I2C0_SDA/USCI1_CTL1/SC0_DAT/PWM0_CH1/PSIO0_CH5/UART2_RXD/TM1/INT1
3	PB.3/EADC0_CH3/ACMP0_N/EBI_ADR2/I2C1_SCL/UART1_TXD/USCI1_DAT1/SC0_RST/PWM0_CH2/PSIO0_CH6/PWM0_BRAKE0/TM2/INT2
4	PB.2/EADC0_CH2/ACMP0_P1/EBI_ADR3/I2C1_SDA/UART1_RXD/USCI1_DAT0/SC0_PWR/PWM0_CH3/PSIO0_CH...

	7/TM3/INT3
5	PB.1/EADC0_CH1/EBI_ADR8/UART2_TXD/USCI1_CLK/I2C1_SCL/QSPI0_MISO1/PWM0_CH4/PWM1_CH4/PWM0_BRAKE0
6	PB.0/EADC0_CH0/EBI_ADR9/UART2_RXD/SPI0_I2SMCLK/I2C1_SDA/QSPI0_MOSI1/PWM0_CH5/PWM1_CH5/PWM0_BRAKE1
7	PA.11/ACMP0_P0/EBI_nRD/USCI0_CLK/BPWM0_CH0/TM0_EXT
8	PA.10/ACMP1_P0/EBI_nWR/USCI0_DAT0/BPWM0_CH1/TM1_EXT
9	PA.9/EBI_MCLK/USCI0_DAT1/UART1_TXD/BPWM0_CH2/TM2_EXT
10	PA.8/EBI_ALE/USCI0_CTL1/UART1_RXD/BPWM0_CH3/TM3_EXT/INT4
11	PF.5/UART2_RXD/UART2_nCTS/PWM0_CH0/BPWM0_CH4/X32_IN/EADC0_ST
12	PF.4/UART2_TXD/UART2_nRTS/PWM0_CH1/BPWM0_CH5/X32_OUT
13	PF.3/EBI_nCS0/UART0_TXD/I2C0_SCL/XT1_IN/BPWM1_CH0
14	PF.2/EBI_nCS1/UART0_RXD/I2C0_SDA/QSPI0_CLK/XT1_OUT/BPWM1_CH1
15	PA.7/EBI_AD7/UART0_TXD/I2C1_SCL/PWM1_CH4/BPWM1_CH2/ACMP0_WLAT/TM2/INT1
16	PA.6/EBI_AD6/UART0_RXD/I2C1_SDA/PWM1_CH5/BPWM1_CH3/ACMP1_WLAT/TM3/INT0
17	PA.5/QSPI0_MISO1/UART0_nCTS/UART0_TXD/I2C0_SCL/BPWM0_CH5/PWM0_CH0
18	PA.4/QSPI0_MOSI1/SPI0_I2SMCLK/SC0_nCD/UART0_nRTS/UART0_RXD/I2C0_SDA/USCI2_CTL1/BPWM0_CH4/PWM0_CH1
19	PA.3/QSPI0_SS/SPI0_SS/SC0_PWR/I2C0_SMBAL/UART1_TXD/I2C1_SCL/PSIO0_CH4/USCI2_CTL0/BPWM0_CH3/PWM0_CH2/CLKO/PWM1_BRAKE1
20	PA.2/QSPI0_CLK/SPI0_CLK/SC0_RST/I2C0_SMBSUS/UART1_RXD/I2C1_SDA/PSIO0_CH5/USCI2_CLK/BPWM0_CH2/PWM0_CH3
21	PA.1/QSPI0_MISO0/SPI0_MISO/SC0_DAT/UART0_TXD/UART1_nCTS/PSIO0_CH6/USCI2_DAT0/BPWM0_CH1/PWM0_CH4
22	PA.0/QSPI0_MOSI0/SPI0_MOSI/SC0_CLK/UART0_RXD/UART1_nRTS/PSIO0_CH7/USCI2_DAT1/BPWM0_CH0/PWM0_CH5
23	V <sub>DDIO</sub>
24	nRESET <b>Note:</b> It is recommended to use 10 kΩ pull-up resistor and 10 uF capacitor on nRESET pin.
25	PF.0/UART1_TXD/I2C1_SCL/UART0_TXD/BPWM1_CH0/ICE_DAT <b>Note:</b> It is recommended to use 100 kΩ pull-up resistor on ICE_DAT pin.
26	PF.1/UART1_RXD/I2C1_SDA/UART0_RXD/BPWM1_CH1/ICE_CLK <b>Note:</b> It is recommended to use 100 kΩ pull-up resistor on ICE_CLK pin.
27	PC.5/EBI_AD5/QSPI0_MISO1/UART2_TXD/I2C1_SCL/PWM1_CH0/PSIO0_CH0
28	PC.4/EBI_AD4/QSPI0_MOSI1/UART2_RXD/I2C1_SDA/PWM1_CH1/USCI2_CTL1/PSIO0_CH1
29	PC.3/EBI_AD3/QSPI0_SS/UART2_nRTS/I2C0_SMBAL/PWM1_CH2/USCI2_CTL0/PSIO0_CH2
30	PC.2/EBI_AD2/QSPI0_CLK/UART2_nCTS/I2C0_SMBSUS/PWM1_CH3/USCI2_CLK/PSIO0_CH3
31	PC.1/EBI_AD1/QSPI0_MISO0/UART2_TXD/I2C0_SCL/PWM1_CH4/USCI2_DAT0/ACMP0_O
32	PC.0/EBI_AD0/QSPI0_MOSI0/UART2_RXD/I2C0_SDA/PWM1_CH5/USCI2_DAT1/ACMP1_O
33	USB_VBUS

34	USB_D-
35	USB_D+
36	USB_VDD33_CAP
37	V <sub>SS</sub>
38	LDO_CAP
39	V <sub>DD</sub>
40	PC.14/EBI_AD11/SPI0_I2SMCLK/USCI0_CTL0/QSPI0_CLK/USCI2_CLK/TM1
41	PB.15/EADC0_CH15/EBI_AD12/SPI0_SS/USCI0_CTL1/UART0_nCTS/PSIO0_CH0/PWM1_CH0/TM0_EXT/PWM0_BRAKE1
42	PB.14/EADC0_CH14/EBI_AD13/SPI0_CLK/USCI0_DAT1/UART0_nRTS/PSIO0_CH1/PWM1_CH1/TM1_EXT/CLKO
43	PB.13/EADC0_CH13/ACMP0_P3/ACMP1_P3/EBI_AD14/SPI0_MISO/USCI0_DAT0/UART0_TXD/PSIO0_CH2/PWM1_CH2/TM2_EXT
44	PB.12/EADC0_CH12/ACMP0_P2/ACMP1_P2/EBI_AD15/SPI0_MOSI/USCI0_CLK/UART0_RXD/PSIO0_CH3/PWM1_CH3/TM3_EXT
45	AV <sub>DD</sub>
46	AV <sub>SS</sub>
47	PB.7/EADC0_CH7/EBI_nWRL/USCI1_DAT0/UART1_TXD/EBI_nCS0/BPWM1_CH4/PWM1_BRAKE0/PWM1_CH4/INT5/ACMP0_O
48	PB.6/EADC0_CH6/EBI_nWRH/USCI1_DAT1/UART1_RXD/EBI_nCS1/BPWM1_CH5/PWM1_BRAKE1/PWM1_CH5/INT4/ACMP1_O

Table 4.1-18 M252LE3AE Multi-function Pin Table

Corresponding Part Number: M252LG6AE

M252LG6AE

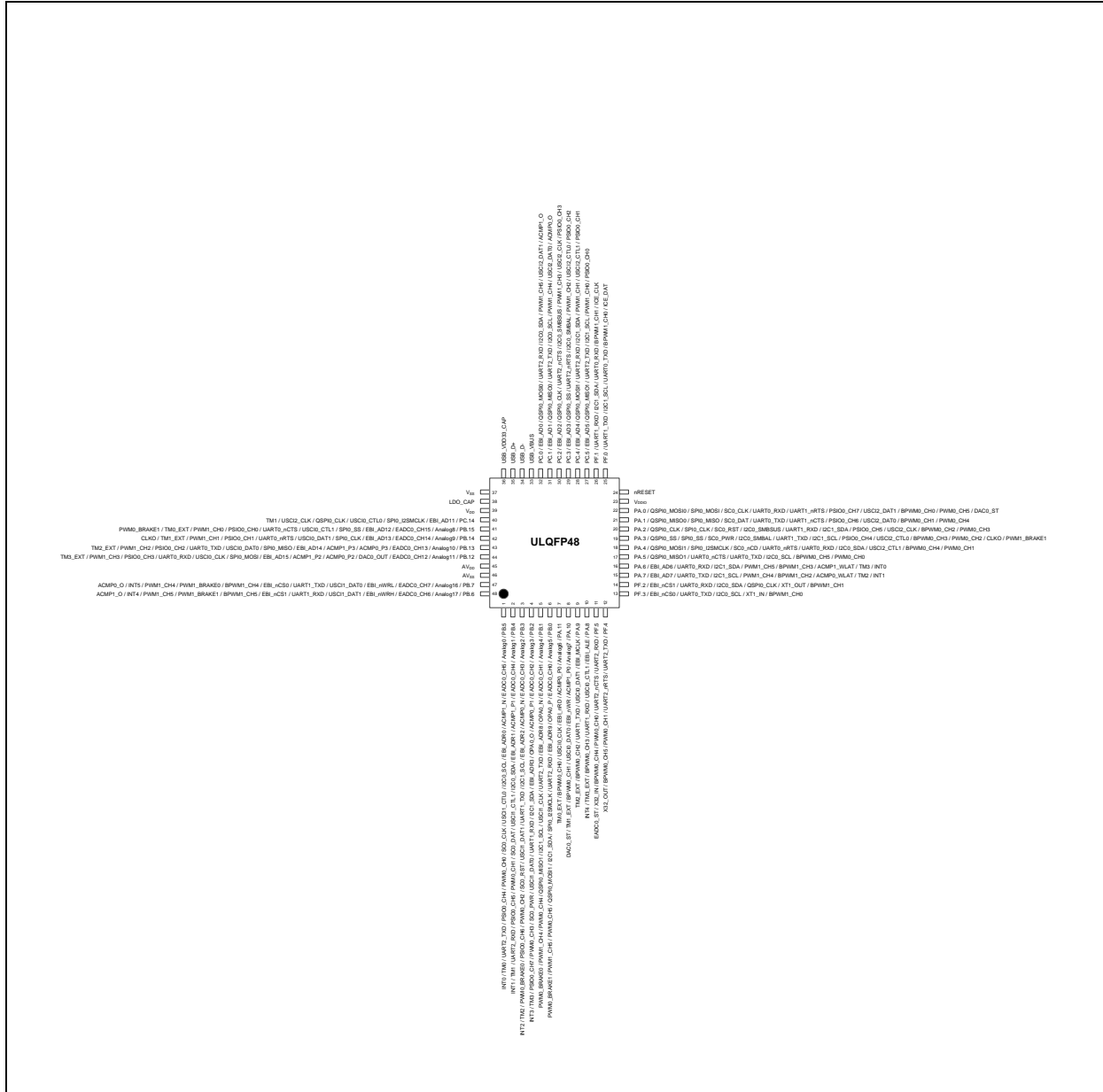

Figure 4.1-33 M252LG6AE Function Pin Diagram

Pin	M252LG6AE Pin Function
1	PB.5/EADC0_CH5/ACMP1_N/EBI_ADR0/I2C0_SCL/USCI1_CTL0/SC0_CLK/PWM0_CH0/PSIO0_CH4/UART2_TXD/TM0/INT0
2	PB.4/EADC0_CH4/ACMP1_P1/EBI_ADR1/I2C0_SDA/USCI1_CTL1/SC0_DAT/PWM0_CH1/PSIO0_CH5/UART2_RXD/TM1/INT1
3	PB.3/EADC0_CH3/ACMP0_N/EBI_ADR2/I2C1_SCL/UART1_TXD/USCI1_DAT1/SC0_RST/PWM0_CH2/PSIO0_CH6/PWM0_BRAKE0/TM2/INT2

4	PB.2/EADC0_CH2/ACMP0_P1/OPA0_O/EBI_ADR3/I2C1_SDA/UART1_RXD/USCI1_DAT0/SC0_PWR/PWM0_CH3/P SIO0_CH7/TM3/INT3
5	PB.1/EADC0_CH1/OPA0_N/EBI_ADR8/UART2_TXD/USCI1_CLK/I2C1_SCL/QSPI0_MISO1/PWM0_CH4/PWM1_CH 4/PWM0_BRAKE0
6	PB.0/EADC0_CH0/OPA0_P/EBI_ADR9/UART2_RXD/SPI0_I2SMCLK/I2C1_SDA/QSPI0_MOSI1/PWM0_CH5/PWM1_ CH5/PWM0_BRAKE1
7	PA.11/ACMP0_P0/EBI_nRD/USCI0_CLK/BPWM0_CH0/TM0_EXT
8	PA.10/ACMP1_P0/EBI_nWR/USCI0_DAT0/BPWM0_CH1/TM1_EXT/DAC0_ST
9	PA.9/EBI_MCLK/USCI0_DAT1/UART1_TXD/BPWM0_CH2/TM2_EXT
10	PA.8/EBI_ALE/USCI0_CTL1/UART1_RXD/BPWM0_CH3/TM3_EXT/INT4
11	PF.5/UART2_RXD/UART2_nCTS/PWM0_CH0/BPWM0_CH4/X32_IN/EADC0_ST
12	PF.4/UART2_TXD/UART2_nRTS/PWM0_CH1/BPWM0_CH5/X32_OUT
13	PF.3/EBI_nCS0/UART0_TXD/I2C0_SCL/XT1_IN/BPWM1_CH0
14	PF.2/EBI_nCS1/UART0_RXD/I2C0_SDA/QSPI0_CLK/XT1_OUT/BPWM1_CH1
15	PA.7/EBI_AD7/UART0_TXD/I2C1_SCL/PWM1_CH4/BPWM1_CH2/ACMP0_WLAT/TM2/INT1
16	PA.6/EBI_AD6/UART0_RXD/I2C1_SDA/PWM1_CH5/BPWM1_CH3/ACMP1_WLAT/TM3/INT0
17	PA.5/QSPI0_MISO1/UART0_nCTS/UART0_TXD/I2C0_SCL/BPWM0_CH5/PWM0_CH0
18	PA.4/QSPI0_MOSI1/SPI0_I2SMCLK/SC0_nCD/UART0_nRTS/UART0_RXD/I2C0_SDA/USCI2_CTL1/BPWM0_CH4/P WM0_CH1
19	PA.3/QSPI0_SS/SPI0_SS/SC0_PWR/I2C0_SMBAL/UART1_TXD/I2C1_SCL/PSIO0_CH4/USCI2_CTL0/BPWM0_CH3/ PWM0_CH2/CLKO/PWM1_BRAKE1
20	PA.2/QSPI0_CLK/SPI0_CLK/SC0_RST/I2C0_SMBUS/UART1_RXD/I2C1_SDA/PSIO0_CH5/USCI2_CLK/BPWM0_C H2/PWM0_CH3
21	PA.1/QSPI0_MISO0/SPI0_MISO/SC0_DAT/UART0_TXD/UART1_nCTS/PSIO0_CH6/USCI2_DAT0/BPWM0_CH1/PW M0_CH4
22	PA.0/QSPI0_MOSI0/SPI0_MOSI/SC0_CLK/UART0_RXD/UART1_nRTS/PSIO0_CH7/USCI2_DAT1/BPWM0_CH0/PW M0_CH5/DAC0_ST
23	V <sub>DDIO</sub>
24	nRESET <b>Note:</b> It is recommended to use 10 kΩ pull-up resistor and 10 uF capacitor on nRESET pin.
25	PF.0/UART1_TXD/I2C1_SCL/UART0_TXD/BPWM1_CH0/ICE_DAT <b>Note:</b> It is recommended to use 100 kΩ pull-up resistor on ICE_DAT pin.
26	PF.1/UART1_RXD/I2C1_SDA/UART0_RXD/BPWM1_CH1/ICE_CLK <b>Note:</b> It is recommended to use 100 kΩ pull-up resistor on ICE_CLK pin.
27	PC.5/EBI_AD5/QSPI0_MISO1/UART2_TXD/I2C1_SCL/PWM1_CH0/PSIO0_CH0
28	PC.4/EBI_AD4/QSPI0_MOSI1/UART2_RXD/I2C1_SDA/PWM1_CH1/USCI2_CTL1/PSIO0_CH1
29	PC.3/EBI_AD3/QSPI0_SS/UART2_nRTS/I2C0_SMBAL/PWM1_CH2/USCI2_CTL0/PSIO0_CH2
30	PC.2/EBI_AD2/QSPI0_CLK/UART2_nCTS/I2C0_SMBUS/PWM1_CH3/USCI2_CLK/PSIO0_CH3
31	PC.1/EBI_AD1/QSPI0_MISO0/UART2_TXD/I2C0_SCL/PWM1_CH4/USCI2_DAT0/ACMP0_O
32	PC.0/EBI_AD0/QSPI0_MOSI0/UART2_RXD/I2C0_SDA/PWM1_CH5/USCI2_DAT1/ACMP1_O

33	USB_VBUS
34	USB_D-
35	USB_D+
36	USB_VDD33_CAP
37	V <sub>SS</sub>
38	LDO_CAP
39	V <sub>DD</sub>
40	PC.14/EBI_AD11/SPI0_I2SMCLK/USCI0_CTL0/QSPI0_CLK/USCI2_CLK/TM1
41	PB.15/EADC0_CH15/EBI_AD12/SPI0_SS/USCI0_CTL1/UART0_nCTS/PSIO0_CH0/PWM1_CH0/TM0_EXT/PWM0_BRAKE1
42	PB.14/EADC0_CH14/EBI_AD13/SPI0_CLK/USCI0_DAT1/UART0_nRTS/PSIO0_CH1/PWM1_CH1/TM1_EXT/CLKO
43	PB.13/EADC0_CH13/ACMP0_P3/ACMP1_P3/EBI_AD14/SPI0_MISO/USCI0_DAT0/UART0_TXD/PSIO0_CH2/PWM1_CH2/TM2_EXT
44	PB.12/EADC0_CH12/DAC0_OUT/ACMP0_P2/ACMP1_P2/EBI_AD15/SPI0_MOSI/USCI0_CLK/UART0_RXD/PSIO0_CH3/PWM1_CH3/TM3_EXT
45	AV <sub>DD</sub>
46	AV <sub>SS</sub>
47	PB.7/EADC0_CH7/EBI_nWRL/USCI1_DAT0/UART1_TXD/EBI_nCS0/BPWM1_CH4/PWM1_BRAKE0/PWM1_CH4/INT5/ACMP0_O
48	PB.6/EADC0_CH6/EBI_nWRH/USCI1_DAT1/UART1_RXD/EBI_nCS1/BPWM1_CH5/PWM1_BRAKE1/PWM1_CH5/INT4/ACMP1_O

Table 4.1-19 M252LG6AE Multi-function Pin Table



4	PB.3/EADC0_CH3/ACMP0_N/I2C1_SCL/UART1_TXD/USCI1_DAT1/SC0_RST/PWM0_CH2/PWM0_BRAKE0/TM2/INT2
5	PB.2/EADC0_CH2/ACMP0_P1/I2C1_SDA/UART1_RXD/USCI1_DAT0/SC0_PWR/PWM0_CH3/TM3/INT3
6	PB.1/EADC0_CH1/UART2_TXD/USCI1_CLK/I2C1_SCL/QSPI0_MISO1/PWM0_CH4/PWM1_CH4/PWM0_BRAKE0
7	PB.0/EADC0_CH0/UART2_RXD/SPI0_I2SMCLK/I2C1_SDA/QSPI0_MOSI1/PWM0_CH5/PWM1_CH5/PWM0_BRAKE1
8	PA.11/ACMP0_P0/USCI0_CLK/BPWM0_CH0/TM0_EXT
9	PA.10/ACMP1_P0/USCI0_DAT0/BPWM0_CH1/TM1_EXT
10	PA.9/USCI0_DAT1/UART1_TXD/BPWM0_CH2/TM2_EXT
11	PA.8/USCI0_CTL1/UART1_RXD/BPWM0_CH3/TM3_EXT/INT4
12	PF.6/SC0_CLK/SPI0_MOSI/TAMPER0
13	PF.14/PWM1_BRAKE0/PWM0_BRAKE0/PSIO0_CH3/PWM0_CH4/CLKO/TM3/INT5
14	PF.5/UART2_RXD/UART2_nCTS/PWM0_CH0/BPWM0_CH4/X32_IN/EADC0_ST
15	PF.4/UART2_TXD/UART2_nRTS/PWM0_CH1/BPWM0_CH5/X32_OUT
16	PF.3/UART0_TXD/I2C0_SCL/XT1_IN/BPWM1_CH0
17	PF.2/UART0_RXD/I2C0_SDA/QSPI0_CLK/XT1_OUT/BPWM1_CH1
18	PC.7/UART0_nCTS/I2C1_SMBAL/PWM1_CH2/BPWM1_CH0/TM0/INT3
19	PC.6/UART0_nRTS/I2C1_SMBSUS/PWM1_CH3/BPWM1_CH1/TM1/INT2
20	PA.7/UART0_TXD/I2C1_SCL/PWM1_CH4/BPWM1_CH2/ACMP0_WLAT/TM2/INT1
21	PA.6/UART0_RXD/I2C1_SDA/PWM1_CH5/BPWM1_CH3/ACMP1_WLAT/TM3/INT0
22	V <sub>SS</sub>
23	V <sub>DD</sub>
24	PD.15/PWM0_CH5/TM3/INT1
25	PA.5/QSPI0_MISO1/UART0_nCTS/UART0_TXD/I2C0_SCL/BPWM0_CH5/PWM0_CH0
26	PA.4/QSPI0_MOSI1/SPI0_I2SMCLK/SC0_nCD/UART0_nRTS/UART0_RXD/I2C0_SDA/BPWM0_CH4/PWM0_CH1
27	PA.3/QSPI0_SS/SPI0_SS/SC0_PWR/I2C0_SMBAL/UART1_TXD/I2C1_SCL/BPWM0_CH3/PWM0_CH2/CLKO/PWM1_BRAKE1
28	PA.2/QSPI0_CLK/SPI0_CLK/SC0_RST/I2C0_SMBSUS/UART1_RXD/I2C1_SDA/BPWM0_CH2/PWM0_CH3
29	PA.1/QSPI0_MISO0/SPI0_MISO/SC0_DAT/UART0_TXD/UART1_nCTS/BPWM0_CH1/PWM0_CH4
30	PA.0/QSPI0_MOSI0/SPI0_MOSI/SC0_CLK/UART0_RXD/UART1_nRTS/BPWM0_CH0/PWM0_CH5
31	V <sub>DDIO</sub>
32	nRESET <b>Note:</b> It is recommended to use 10 kΩ pull-up resistor and 10 uF capacitor on nRESET pin.
33	PF.0/UART1_TXD/I2C1_SCL/UART0_TXD/BPWM1_CH0/ICE_DAT <b>Note:</b> It is recommended to use 100 kΩ pull-up resistor on ICE_DAT pin.
34	PF.1/UART1_RXD/I2C1_SDA/UART0_RXD/BPWM1_CH1/ICE_CLK <b>Note:</b> It is recommended to use 100 kΩ pull-up resistor on ICE_CLK pin.
35	PC.5/QSPI0_MISO1/UART2_TXD/I2C1_SCL/PWM1_CH0/PSIO0_CH0

36	PC.4/QSPI0_MOSI1/UART2_RXD/I2C1_SDA/PWM1_CH1/PSIO0_CH1
37	PC.3/QSPI0_SS/UART2_nRTS/I2C0_SMBAL/PWM1_CH2/PSIO0_CH2
38	PC.2/QSPI0_CLK/UART2_nCTS/I2C0_SMBSUS/PWM1_CH3/PSIO0_CH3
39	PC.1/QSPI0_MISO0/UART2_TXD/I2C0_SCL/PWM1_CH4/ACMP0_O
40	PC.0/QSPI0_MOSI0/UART2_RXD/I2C0_SDA/PWM1_CH5/ACMP1_O
41	PD.3/USCI0_CTL1/SPI0_SS/USCI1_CTL0/UART0_TXD
42	PD.2/USCI0_DAT1/SPI0_CLK/UART0_RXD
43	PD.1/USCI0_DAT0/SPI0_MISO
44	PD.0/USCI0_CLK/SPI0_MOSI/TM2
45	USB_VBUS
46	USB_D-
47	USB_D+
48	USB_VDD33_CAP
49	V <sub>SS</sub>
50	LDO_CAP
51	V <sub>DD</sub>
52	PC.14/SPI0_I2SMCLK/USCI0_CTL0/QSPI0_CLK/TM1
53	PB.15/EADC0_CH15/SPI0_SS/USCI0_CTL1/UART0_nCTS/PSIO0_CH0/PWM1_CH0/TM0_EXT/PWM0_BRAKE1
54	PB.14/EADC0_CH14/SPI0_CLK/USCI0_DAT1/UART0_nRTS/PSIO0_CH1/PWM1_CH1/TM1_EXT/CLKO
55	PB.13/EADC0_CH13/ACMP0_P3/ACMP1_P3/SPI0_MISO/USCI0_DAT0/UART0_TXD/PSIO0_CH2/PWM1_CH2/TM2_EXT
56	PB.12/EADC0_CH12/ACMP0_P2/ACMP1_P2/SPI0_MOSI/USCI0_CLK/UART0_RXD/PSIO0_CH3/PWM1_CH3/TM3_EXT
57	AV <sub>DD</sub>
58	V <sub>REF</sub>
59	AV <sub>SS</sub>
60	PB.11/EADC0_CH11/UART0_nCTS/I2C1_SCL/SPI0_I2SMCLK/BPWM1_CH0
61	PB.10/EADC0_CH10/USCI1_CTL0/UART0_nRTS/I2C1_SDA/BPWM1_CH1
62	PB.9/EADC0_CH9/USCI1_CTL1/UART0_TXD/UART1_nCTS/I2C1_SMBAL/BPWM1_CH2
63	PB.8/EADC0_CH8/USCI1_CLK/UART0_RXD/UART1_nRTS/I2C1_SMBSUS/BPWM1_CH3
64	PB.7/EADC0_CH7/USCI1_DAT0/UART1_TXD/BPWM1_CH4/PWM1_BRAKE0/PWM1_CH4/INT5/ACMP0_O

Table 4.1-20 M252SC2AE/M252SD2AE Multi-function Pin Table

Corresponding Part Number: M252SE3AE

M252SE3AE

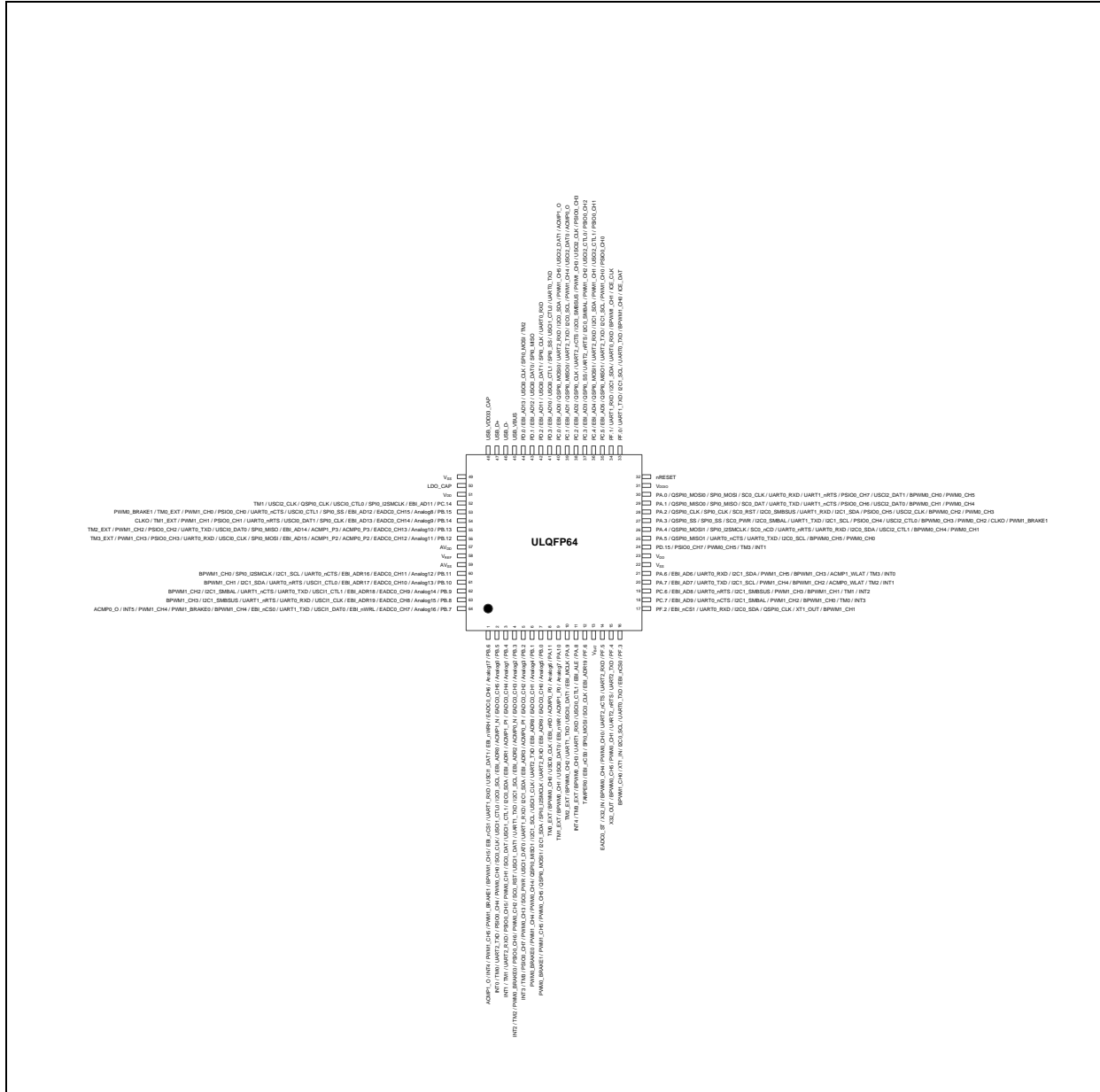

Figure 4.1-35 M252SE3AE Function Pin Diagram

Pin	M252SE3AE Pin Function
1	PB.6/EADC0_CH6/EBI_nWRH/USC11_DAT1/UART1_RXD/EBI_nCS1/BPWM1_CH5/PWM1_BRAKE1/PWM1_CH5/INT4/ACMP1_0
2	PB.5/EADC0_CH5/ACMP1_N/EBI_ADR0/I2C0_SCL/USC11_CTL0/SC0_CLK/PWM0_CH0/PSIO0_CH4/UART2_TXD/TM0/INT0
3	PB.4/EADC0_CH4/ACMP1_P1/EBI_ADR1/I2C0_SDA/USC11_CTL1/SC0_DAT/PWM0_CH1/PSIO0_CH5/UART2_RXD/TM1/INT1
4	PB.3/EADC0_CH3/ACMP0_N/EBI_ADR2/I2C1_SCL/UART1_TXD/USC11_DAT1/SC0_RST/PWM0_CH2/PSIO0_CH6/

	PWM0_BRAKE0/TM2/INT2
5	PB.2/EADC0_CH2/ACMP0_P1/EBI_ADR3/I2C1_SDA/UART1_RXD/USCI1_DAT0/SC0_PWR/PWM0_CH3/PSIO0_CH7/TM3/INT3
6	PB.1/EADC0_CH1/EBI_ADR8/UART2_TXD/USCI1_CLK/I2C1_SCL/QSPI0_MISO1/PWM0_CH4/PWM1_CH4/PWM0_BRAKE0
7	PB.0/EADC0_CH0/EBI_ADR9/UART2_RXD/SPI0_I2SMCLK/I2C1_SDA/QSPI0_MOSI1/PWM0_CH5/PWM1_CH5/PWM0_BRAKE1
8	PA.11/ACMP0_P0/EBI_nRD/USCI0_CLK/BPWM0_CH0/TM0_EXT
9	PA.10/ACMP1_P0/EBI_nWR/USCI0_DAT0/BPWM0_CH1/TM1_EXT
10	PA.9/EBI_MCLK/USCI0_DAT1/UART1_TXD/BPWM0_CH2/TM2_EXT
11	PA.8/EBI_ALE/USCI0_CTL1/UART1_RXD/BPWM0_CH3/TM3_EXT/INT4
12	PF.6/EBI_ADR19/SC0_CLK/SPI0_MOSI/EBI_nCS0/TAMPER0
13	V <sub>BAT</sub>
14	PF.5/UART2_RXD/UART2_nCTS/PWM0_CH0/BPWM0_CH4/X32_IN/EADC0_ST
15	PF.4/UART2_TXD/UART2_nRTS/PWM0_CH1/BPWM0_CH5/X32_OUT
16	PF.3/EBI_nCS0/UART0_TXD/I2C0_SCL/XT1_IN/BPWM1_CH0
17	PF.2/EBI_nCS1/UART0_RXD/I2C0_SDA/QSPI0_CLK/XT1_OUT/BPWM1_CH1
18	PC.7/EBI_AD9/UART0_nCTS/I2C1_SMBAL/PWM1_CH2/BPWM1_CH0/TM0/INT3
19	PC.6/EBI_AD8/UART0_nRTS/I2C1_SMBSUS/PWM1_CH3/BPWM1_CH1/TM1/INT2
20	PA.7/EBI_AD7/UART0_TXD/I2C1_SCL/PWM1_CH4/BPWM1_CH2/ACMP0_WLAT/TM2/INT1
21	PA.6/EBI_AD6/UART0_RXD/I2C1_SDA/PWM1_CH5/BPWM1_CH3/ACMP1_WLAT/TM3/INT0
22	V <sub>SS</sub>
23	V <sub>DD</sub>
24	PD.15/PSIO0_CH7/PWM0_CH5/TM3/INT1
25	PA.5/QSPI0_MISO1/UART0_nCTS/UART0_TXD/I2C0_SCL/BPWM0_CH5/PWM0_CH0
26	PA.4/QSPI0_MOSI1/SPI0_I2SMCLK/SC0_nCD/UART0_nRTS/UART0_RXD/I2C0_SDA/USCI2_CTL1/BPWM0_CH4/PWM0_CH1
27	PA.3/QSPI0_SS/SPI0_SS/SC0_PWR/I2C0_SMBAL/UART1_TXD/I2C1_SCL/PSIO0_CH4/USCI2_CTL0/BPWM0_CH3/PWM0_CH2/CLKO/PWM1_BRAKE1
28	PA.2/QSPI0_CLK/SPI0_CLK/SC0_RST/I2C0_SMBSUS/UART1_RXD/I2C1_SDA/PSIO0_CH5/USCI2_CLK/BPWM0_CH2/PWM0_CH3
29	PA.1/QSPI0_MISO0/SPI0_MISO/SC0_DAT/UART0_TXD/UART1_nCTS/PSIO0_CH6/USCI2_DAT0/BPWM0_CH1/PWM0_CH4
30	PA.0/QSPI0_MOSI0/SPI0_MOSI/SC0_CLK/UART0_RXD/UART1_nRTS/PSIO0_CH7/USCI2_DAT1/BPWM0_CH0/PWM0_CH5
31	V <sub>DDIO</sub>
32	nRESET <b>Note:</b> It is recommended to use 10 kΩ pull-up resistor and 10 uF capacitor on nRESET pin.
33	PF.0/UART1_TXD/I2C1_SCL/UART0_TXD/BPWM1_CH0/ICE_DAT <b>Note:</b> It is recommended to use 100 kΩ pull-up resistor on ICE_DAT pin.

34	PF.1/UART1_RXD/I2C1_SDA/UART0_RXD/BPWM1_CH1/ICE_CLK <b>Note:</b> It is recommended to use 100 kΩ pull-up resistor on ICE_CLK pin.
35	PC.5/EBI_AD5/QSPI0_MISO1/UART2_TXD/I2C1_SCL/PWM1_CH0/PSIO0_CH0
36	PC.4/EBI_AD4/QSPI0_MOSI1/UART2_RXD/I2C1_SDA/PWM1_CH1/USCI2_CTL1/PSIO0_CH1
37	PC.3/EBI_AD3/QSPI0_SS/UART2_nRTS/I2C0_SMBAL/PWM1_CH2/USCI2_CTL0/PSIO0_CH2
38	PC.2/EBI_AD2/QSPI0_CLK/UART2_nCTS/I2C0_SMBSUS/PWM1_CH3/USCI2_CLK/PSIO0_CH3
39	PC.1/EBI_AD1/QSPI0_MISO0/UART2_TXD/I2C0_SCL/PWM1_CH4/USCI2_DAT0/ACMP0_O
40	PC.0/EBI_AD0/QSPI0_MOSI0/UART2_RXD/I2C0_SDA/PWM1_CH5/USCI2_DAT1/ACMP1_O
41	PD.3/EBI_AD10/USCI0_CTL1/SPI0_SS/USCI1_CTL0/UART0_TXD
42	PD.2/EBI_AD11/USCI0_DAT1/SPI0_CLK/UART0_RXD
43	PD.1/EBI_AD12/USCI0_DAT0/SPI0_MISO
44	PD.0/EBI_AD13/USCI0_CLK/SPI0_MOSI/TM2
45	USB_VBUS
46	USB_D-
47	USB_D+
48	USB_VDD33_CAP
49	V <sub>SS</sub>
50	LDO_CAP
51	V <sub>DD</sub>
52	PC.14/EBI_AD11/SPI0_I2SMCLK/USCI0_CTL0/QSPI0_CLK/USCI2_CLK/TM1
53	PB.15/EADC0_CH15/EBI_AD12/SPI0_SS/USCI0_CTL1/UART0_nCTS/PSIO0_CH0/PWM1_CH0/TM0_EXT/PWM0_BRAKE1
54	PB.14/EADC0_CH14/EBI_AD13/SPI0_CLK/USCI0_DAT1/UART0_nRTS/PSIO0_CH1/PWM1_CH1/TM1_EXT/CLKO
55	PB.13/EADC0_CH13/ACMP0_P3/ACMP1_P3/EBI_AD14/SPI0_MISO/USCI0_DAT0/UART0_TXD/PSIO0_CH2/PWM1_CH2/TM2_EXT
56	PB.12/EADC0_CH12/ACMP0_P2/ACMP1_P2/EBI_AD15/SPI0_MOSI/USCI0_CLK/UART0_RXD/PSIO0_CH3/PWM1_CH3/TM3_EXT
57	AV <sub>DD</sub>
58	V <sub>REF</sub>
59	AV <sub>SS</sub>
60	PB.11/EADC0_CH11/EBI_ADR16/UART0_nCTS/I2C1_SCL/SPI0_I2SMCLK/BPWM1_CH0
61	PB.10/EADC0_CH10/EBI_ADR17/USCI1_CTL0/UART0_nRTS/I2C1_SDA/BPWM1_CH1
62	PB.9/EADC0_CH9/EBI_ADR18/USCI1_CTL1/UART0_TXD/UART1_nCTS/I2C1_SMBAL/BPWM1_CH2
63	PB.8/EADC0_CH8/EBI_ADR19/USCI1_CLK/UART0_RXD/UART1_nRTS/I2C1_SMBSUS/BPWM1_CH3
64	PB.7/EADC0_CH7/EBI_nWRL/USCI1_DAT0/UART1_TXD/EBI_nCS0/BPWM1_CH4/PWM1_BRAKE0/PWM1_CH4/INT5/ACMP0_O

Table 4.1-21 M252SE3AE Multi-function Pin Table

Corresponding Part Number: M252SG6AE

M252SG6AE

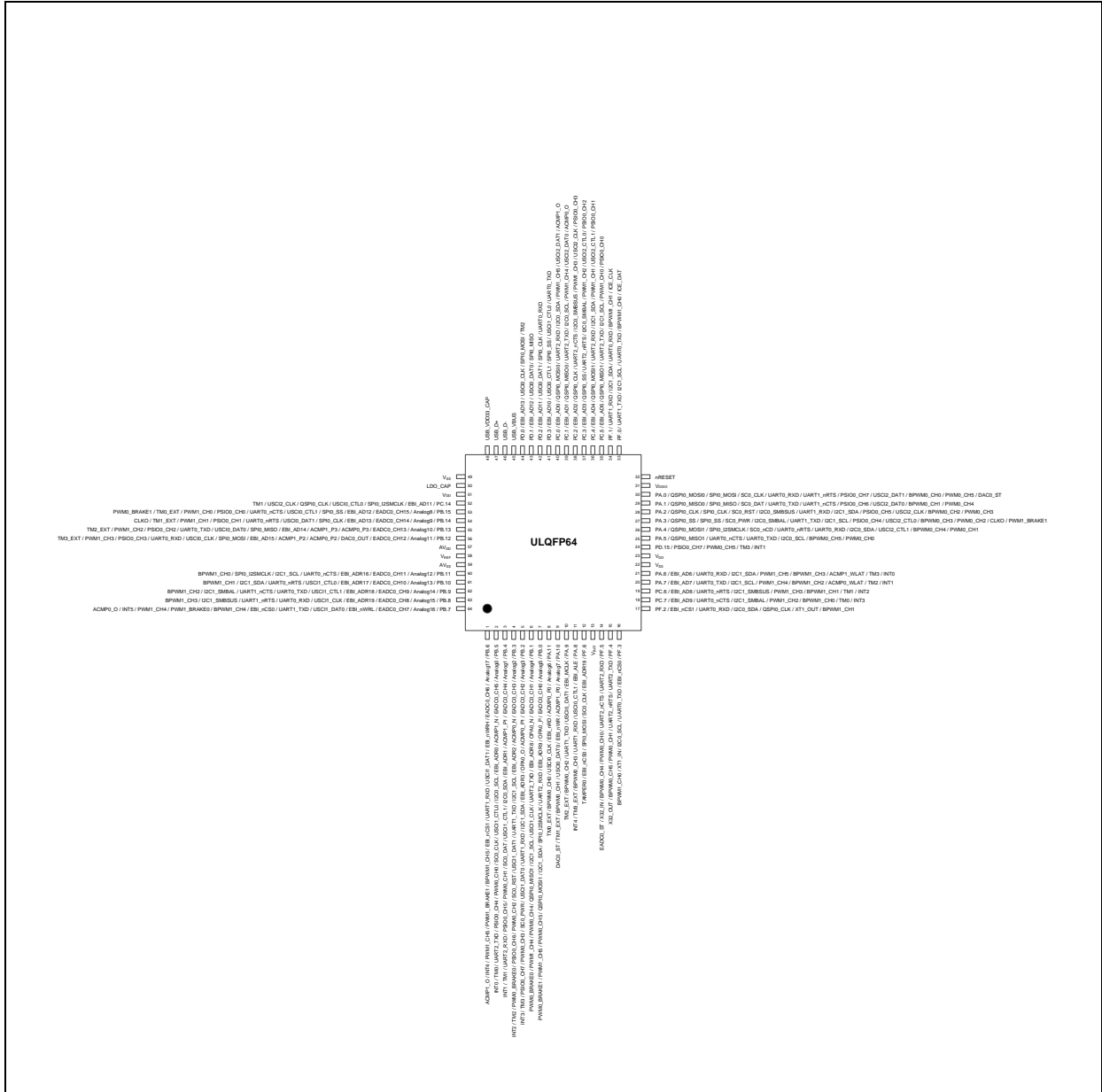

Figure 4.1-36 M252SG3AE Function Pin Diagram

Pin	M252SG6AE Pin Function
1	PB.6/EADC0_CH6/EBI_nWRH/USCI1_DAT1/UART1_RXD/EBI_nCS1/BPWM1_CH5/PWM1_BRAKE1/PWM1_CH5/INT4/ACMP1_O
2	PB.5/EADC0_CH5/ACMP1_N/EBI_ADR0/I2C0_SCL/USCI1_CTL0/SC0_CLK/PWM0_CH0/PSIO0_CH4/UART2_TXD/TM0/INT0
3	PB.4/EADC0_CH4/ACMP1_P1/EBI_ADR1/I2C0_SDA/USCI1_CTL1/SC0_DAT/PWM0_CH1/PSIO0_CH5/UART2_RXD/TM1/INT1

4	PB.3/EADC0_CH3/ACMP0_N/EBI_ADR2/I2C1_SCL/UART1_TXD/USCI1_DAT1/SC0_RST/PWM0_CH2/PSIO0_CH6/PWM0_BRAKE0/TM2/INT2
5	PB.2/EADC0_CH2/ACMP0_P1/OPA0_O/EBI_ADR3/I2C1_SDA/UART1_RXD/USCI1_DAT0/SC0_PWR/PWM0_CH3/PSIO0_CH7/TM3/INT3
6	PB.1/EADC0_CH1/OPA0_N/EBI_ADR8/UART2_TXD/USCI1_CLK/I2C1_SCL/QSPI0_MISO1/PWM0_CH4/PWM1_CH4/PWM0_BRAKE0
7	PB.0/EADC0_CH0/OPA0_P/EBI_ADR9/UART2_RXD/SPI0_I2SMCLK/I2C1_SDA/QSPI0_MOSI1/PWM0_CH5/PWM1_CH5/PWM0_BRAKE1
8	PA.11/ACMP0_P0/EBI_nRD/USCI0_CLK/BPWM0_CH0/TM0_EXT
9	PA.10/ACMP1_P0/EBI_nWR/USCI0_DAT0/BPWM0_CH1/TM1_EXT/DAC0_ST
10	PA.9/EBI_MCLK/USCI0_DAT1/UART1_TXD/BPWM0_CH2/TM2_EXT
11	PA.8/EBI_ALE/USCI0_CTL1/UART1_RXD/BPWM0_CH3/TM3_EXT/INT4
12	PF.6/EBI_ADR19/SC0_CLK/SPI0_MOSI/EBI_nCS0/TAMPER0
13	V <sub>BAT</sub>
14	PF.5/UART2_RXD/UART2_nCTS/PWM0_CH0/BPWM0_CH4/X32_IN/EADC0_ST
15	PF.4/UART2_TXD/UART2_nRTS/PWM0_CH1/BPWM0_CH5/X32_OUT
16	PF.3/EBI_nCS0/UART0_TXD/I2C0_SCL/XT1_IN/BPWM1_CH0
17	PF.2/EBI_nCS1/UART0_RXD/I2C0_SDA/QSPI0_CLK/XT1_OUT/BPWM1_CH1
18	PC.7/EBI_AD9/UART0_nCTS/I2C1_SMBAL/PWM1_CH2/BPWM1_CH0/TM0/INT3
19	PC.6/EBI_AD8/UART0_nRTS/I2C1_SMBSUS/PWM1_CH3/BPWM1_CH1/TM1/INT2
20	PA.7/EBI_AD7/UART0_TXD/I2C1_SCL/PWM1_CH4/BPWM1_CH2/ACMP0_WLAT/TM2/INT1
21	PA.6/EBI_AD6/UART0_RXD/I2C1_SDA/PWM1_CH5/BPWM1_CH3/ACMP1_WLAT/TM3/INT0
22	V <sub>SS</sub>
23	V <sub>DD</sub>
24	PD.15/PSIO0_CH7/PWM0_CH5/TM3/INT1
25	PA.5/QSPI0_MISO1/UART0_nCTS/UART0_TXD/I2C0_SCL/BPWM0_CH5/PWM0_CH0
26	PA.4/QSPI0_MOSI1/SPI0_I2SMCLK/SC0_nCD/UART0_nRTS/UART0_RXD/I2C0_SDA/USCI2_CTL1/BPWM0_CH4/PWM0_CH1
27	PA.3/QSPI0_SS/SPI0_SS/SC0_PWR/I2C0_SMBAL/UART1_TXD/I2C1_SCL/PSIO0_CH4/USCI2_CTL0/BPWM0_CH3/PWM0_CH2/CLKO/PWM1_BRAKE1
28	PA.2/QSPI0_CLK/SPI0_CLK/SC0_RST/I2C0_SMBSUS/UART1_RXD/I2C1_SDA/PSIO0_CH5/USCI2_CLK/BPWM0_CH2/PWM0_CH3
29	PA.1/QSPI0_MISO0/SPI0_MISO/SC0_DAT/UART0_TXD/UART1_nCTS/PSIO0_CH6/USCI2_DAT0/BPWM0_CH1/PWM0_CH4
30	PA.0/QSPI0_MOSI0/SPI0_MOSI/SC0_CLK/UART0_RXD/UART1_nRTS/PSIO0_CH7/USCI2_DAT1/BPWM0_CH0/PWM0_CH5/DAC0_ST
31	V <sub>DDIO</sub>
32	nRESET <b>Note:</b> It is recommended to use 10 kΩ pull-up resistor and 10 uF capacitor on nRESET pin.
33	PF.0/UART1_TXD/I2C1_SCL/UART0_TXD/BPWM1_CH0/ICE_DAT

	<b>Note:</b> It is recommended to use 100 kΩ pull-up resistor on ICE_DAT pin.
34	PF.1/UART1_RXD/I2C1_SDA/UART0_RXD/BPWM1_CH1/ICE_CLK <b>Note:</b> It is recommended to use 100 kΩ pull-up resistor on ICE_CLK pin.
35	PC.5/EBI_AD5/QSPI0_MISO1/UART2_TXD/I2C1_SCL/PWM1_CH0/PSIO0_CH0
36	PC.4/EBI_AD4/QSPI0_MOSI1/UART2_RXD/I2C1_SDA/PWM1_CH1/USCI2_CTL1/PSIO0_CH1
37	PC.3/EBI_AD3/QSPI0_SS/UART2_nRTS/I2C0_SMBAL/PWM1_CH2/USCI2_CTL0/PSIO0_CH2
38	PC.2/EBI_AD2/QSPI0_CLK/UART2_nCTS/I2C0_SMBUS/PWM1_CH3/USCI2_CLK/PSIO0_CH3
39	PC.1/EBI_AD1/QSPI0_MISO0/UART2_TXD/I2C0_SCL/PWM1_CH4/USCI2_DAT0/ACMP0_O
40	PC.0/EBI_AD0/QSPI0_MOSI0/UART2_RXD/I2C0_SDA/PWM1_CH5/USCI2_DAT1/ACMP1_O
41	PD.3/EBI_AD10/USCI0_CTL1/SPI0_SS/USCI1_CTL0/UART0_TXD
42	PD.2/EBI_AD11/USCI0_DAT1/SPI0_CLK/UART0_RXD
43	PD.1/EBI_AD12/USCI0_DAT0/SPI0_MISO
44	PD.0/EBI_AD13/USCI0_CLK/SPI0_MOSI/TM2
45	USB_VBUS
46	USB_D-
47	USB_D+
48	USB_VDD33_CAP
49	V <sub>SS</sub>
50	LDO_CAP
51	V <sub>DD</sub>
52	PC.14/EBI_AD11/SPI0_I2SMCLK/USCI0_CTL0/QSPI0_CLK/USCI2_CLK/TM1
53	PB.15/EADC0_CH15/EBI_AD12/SPI0_SS/USCI0_CTL1/UART0_nCTS/PSIO0_CH0/PWM1_CH0/TM0_EXT/PWM0_BRAKE1
54	PB.14/EADC0_CH14/EBI_AD13/SPI0_CLK/USCI0_DAT1/UART0_nRTS/PSIO0_CH1/PWM1_CH1/TM1_EXT/CLKO
55	PB.13/EADC0_CH13/ACMP0_P3/ACMP1_P3/EBI_AD14/SPI0_MISO/USCI0_DAT0/UART0_TXD/PSIO0_CH2/PWM1_CH2/TM2_EXT
56	PB.12/EADC0_CH12/DAC0_OUT/ACMP0_P2/ACMP1_P2/EBI_AD15/SPI0_MOSI/USCI0_CLK/UART0_RXD/PSIO0_CH3/PWM1_CH3/TM3_EXT
57	AV <sub>DD</sub>
58	V <sub>REF</sub>
59	AV <sub>SS</sub>
60	PB.11/EADC0_CH11/EBI_ADR16/UART0_nCTS/I2C1_SCL/SPI0_I2SMCLK/BPWM1_CH0
61	PB.10/EADC0_CH10/EBI_ADR17/USCI1_CTL0/UART0_nRTS/I2C1_SDA/BPWM1_CH1
62	PB.9/EADC0_CH9/EBI_ADR18/USCI1_CTL1/UART0_TXD/UART1_nCTS/I2C1_SMBAL/BPWM1_CH2
63	PB.8/EADC0_CH8/EBI_ADR19/USCI1_CLK/UART0_RXD/UART1_nRTS/I2C1_SMBUS/BPWM1_CH3
64	PB.7/EADC0_CH7/EBI_nWRL/USCI1_DAT0/UART1_TXD/EBI_nCS0/BPWM1_CH4/PWM1_BRAKE0/PWM1_CH4/INT5/ACMP0_O

Table 4.1-22 M252SG6AE Multi-function Pin Table

4.1.4.6 M252 Series LQFP 128-Pin Multi-function Pin Diagram

Corresponding Part Number: M252KE3AE, M252KG6AE

M252KE3AE

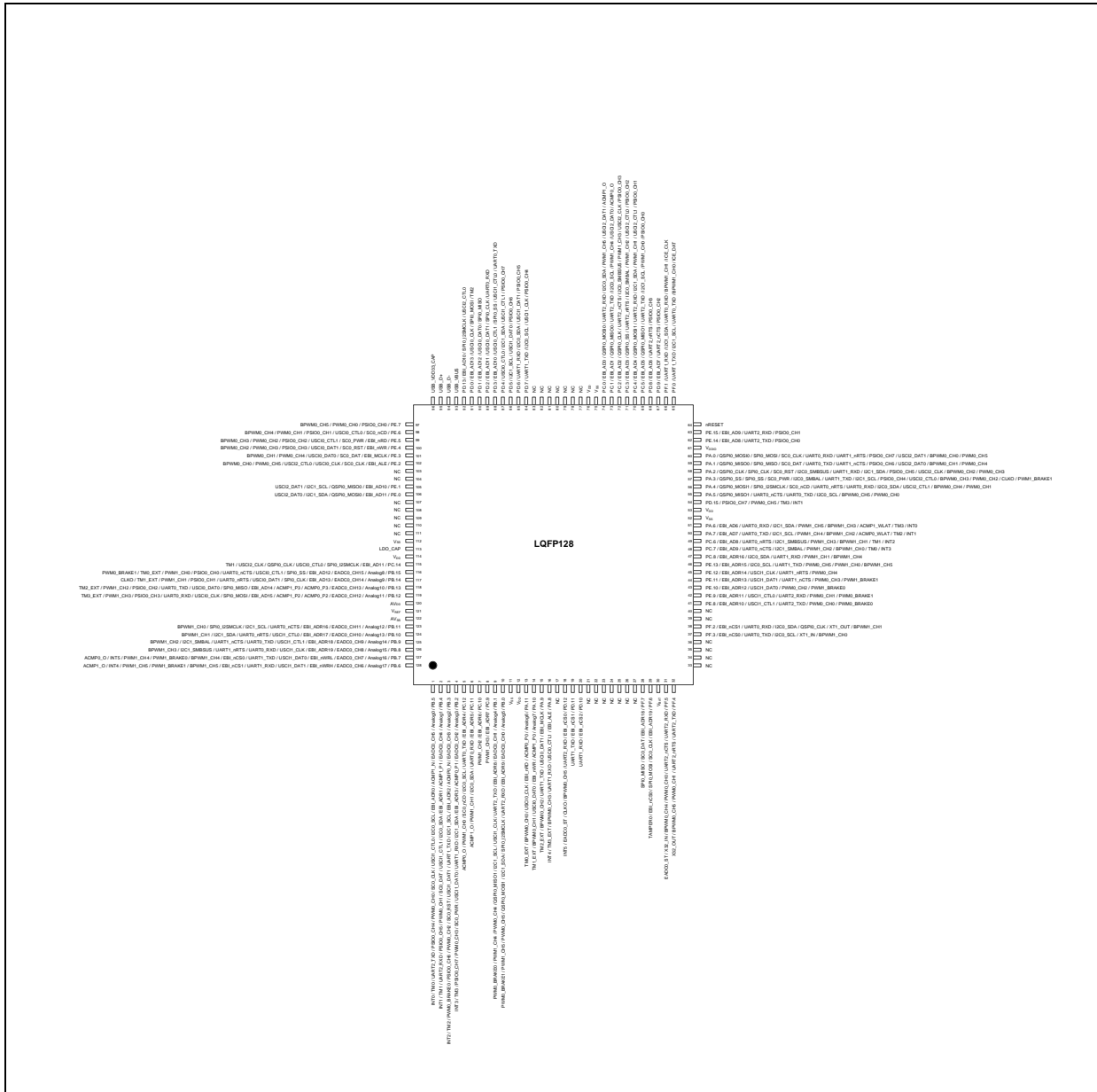

Figure 4.1-37 M252KE3AE Function Pin Diagram

Pin	M252KE3AE Pin Function
1	PB.5/EADC0_CH5/ACMP1_N/EBI_ADR0/I2C0_SCL/USC11_CTL0/SC0_CLK/PWM0_CH0/PSIO0_CH4/UART2_TXD/TM0/INT0
2	PB.4/EADC0_CH4/ACMP1_P1/EBI_ADR1/I2C0_SDA/USC11_CTL1/SC0_DAT/PWM0_CH1/PSIO0_CH5/UART2_RXD/TM1/INT1
3	PB.3/EADC0_CH3/ACMP0_N/EBI_ADR2/I2C1_SCL/UART1_TXD/USC11_DAT1/SC0_RST/PWM0_CH2/PSIO0_CH6/

	PWM0_BRAKE0/TM2/INT2
4	PB.2/EADC0_CH2/ACMP0_P1/EBI_ADR3/I2C1_SDA/UART1_RXD/USCI1_DAT0/SC0_PWR/PWM0_CH3/PSIO0_CH7/TM3/INT3
5	PC.12/EBI_ADR4/UART0_TXD/I2C0_SCL/SC0_nCD/PWM1_CH0/ACMP0_O
6	PC.11/EBI_ADR5/UART0_RXD/I2C0_SDA/PWM1_CH1/ACMP1_O
7	PC.10/EBI_ADR6/PWM1_CH2
8	PC.9/EBI_ADR7/PWM1_CH3
9	PB.1/EADC0_CH1/EBI_ADR8/UART2_TXD/USCI1_CLK/I2C1_SCL/QSPI0_MISO1/PWM0_CH4/PWM1_CH4/PWM0_BRAKE0
10	PB.0/EADC0_CH0/EBI_ADR9/UART2_RXD/SPI0_I2SMCLK/I2C1_SDA/QSPI0_MOSI1/PWM0_CH5/PWM1_CH5/PWM0_BRAKE1
11	V <sub>SS</sub>
12	V <sub>DD</sub>
13	PA.11/ACMP0_P0/EBI_nRD/USCI0_CLK/BPWM0_CH0/TM0_EXT
14	PA.10/ACMP1_P0/EBI_nWR/USCI0_DAT0/BPWM0_CH1/TM1_EXT
15	PA.9/EBI_MCLK/USCI0_DAT1/UART1_TXD/BPWM0_CH2/TM2_EXT
16	PA.8/EBI_ALE/USCI0_CTL1/UART1_RXD/BPWM0_CH3/TM3_EXT/INT4
17	NC
18	PD.12/EBI_nCS0/UART2_RXD/BPWM0_CH5/CLKO/EADC0_ST/INT5
19	PD.11/EBI_nCS1/UART1_TXD
20	PD.10/EBI_nCS2/UART1_RXD
21	NC
22	NC
23	NC
24	NC
25	NC
26	NC
27	NC
28	PF.7/EBI_ADR18/SC0_DAT/SPI0_MISO
29	PF.6/EBI_ADR19/SC0_CLK/SPI0_MOSI/EBI_nCS0/TAMPER0
30	V <sub>BAT</sub>
31	PF.5/UART2_RXD/UART2_nCTS/PWM0_CH0/BPWM0_CH4/X32_IN/EADC0_ST
32	PF.4/UART2_TXD/UART2_nRTS/PWM0_CH1/BPWM0_CH5/X32_OUT
33	NC
34	NC
35	NC
36	NC

37	PF.3/EBI_nCS0/UART0_TXD/I2C0_SCL/XT1_IN/BPWM1_CH0
38	PF.2/EBI_nCS1/UART0_RXD/I2C0_SDA/QSPI0_CLK/XT1_OUT/BPWM1_CH1
39	NC
40	NC
41	PE.8/EBI_ADR10/USCI1_CTL1/UART2_TXD/PWM0_CH0/PWM0_BRAKE0
42	PE.9/EBI_ADR11/USCI1_CTL0/UART2_RXD/PWM0_CH1/PWM0_BRAKE1
43	PE.10/EBI_ADR12/USCI1_DAT0/PWM0_CH2/PWM1_BRAKE0
44	PE.11/EBI_ADR13/USCI1_DAT1/UART1_nCTS/PWM0_CH3/PWM1_BRAKE1
45	PE.12/EBI_ADR14/USCI1_CLK/UART1_nRTS/PWM0_CH4
46	PE.13/EBI_ADR15/I2C0_SCL/UART1_TXD/PWM0_CH5/PWM1_CH0/BPWM1_CH5
47	PC.8/EBI_ADR16/I2C0_SDA/UART1_RXD/PWM1_CH1/BPWM1_CH4
48	PC.7/EBI_AD9/UART0_nCTS/I2C1_SMBAL/PWM1_CH2/BPWM1_CH0/TM0/INT3
49	PC.6/EBI_AD8/UART0_nRTS/I2C1_SMBSUS/PWM1_CH3/BPWM1_CH1/TM1/INT2
50	PA.7/EBI_AD7/UART0_TXD/I2C1_SCL/PWM1_CH4/BPWM1_CH2/ACMP0_WLAT/TM2/INT1
51	PA.6/EBI_AD6/UART0_RXD/I2C1_SDA/PWM1_CH5/BPWM1_CH3/ACMP1_WLAT/TM3/INT0
52	V <sub>SS</sub>
53	V <sub>DD</sub>
54	PD.15/PSIO0_CH7/PWM0_CH5/TM3/INT1
55	PA.5/QSPI0_MISO1/UART0_nCTS/UART0_TXD/I2C0_SCL/BPWM0_CH5/PWM0_CH0
56	PA.4/QSPI0_MOSI1/SPI0_I2SMCLK/SC0_nCD/UART0_nRTS/UART0_RXD/I2C0_SDA/USCI2_CTL1/BPWM0_CH4/PWM0_CH1
57	PA.3/QSPI0_SS/SPI0_SS/SC0_PWR/I2C0_SMBAL/UART1_TXD/I2C1_SCL/PSIO0_CH4/USCI2_CTL0/BPWM0_CH3/PWM0_CH2/CLKO/PWM1_BRAKE1
58	PA.2/QSPI0_CLK/SPI0_CLK/SC0_RST/I2C0_SMBSUS/UART1_RXD/I2C1_SDA/PSIO0_CH5/USCI2_CLK/BPWM0_CH2/PWM0_CH3
59	PA.1/QSPI0_MISO0/SPI0_MISO/SC0_DAT/UART0_TXD/UART1_nCTS/PSIO0_CH6/USCI2_DAT0/BPWM0_CH1/PWM0_CH4
60	PA.0/QSPI0_MOSI0/SPI0_MOSI/SC0_CLK/UART0_RXD/UART1_nRTS/PSIO0_CH7/USCI2_DAT1/BPWM0_CH0/PWM0_CH5
61	V <sub>DDIO</sub>
62	PE.14/EBI_AD8/UART2_TXD/PSIO0_CH0
63	PE.15/EBI_AD9/UART2_RXD/PSIO0_CH1
64	nRESET <b>Note:</b> It is recommended to use 10 kΩ pull-up resistor and 10 uF capacitor on nRESET pin.
65	PF.0/UART1_TXD/I2C1_SCL/UART0_TXD/BPWM1_CH0/ICE_DAT <b>Note:</b> It is recommended to use 100 kΩ pull-up resistor on ICE_DAT pin.
66	PF.1/UART1_RXD/I2C1_SDA/UART0_RXD/BPWM1_CH1/ICE_CLK <b>Note:</b> It is recommended to use 100 kΩ pull-up resistor on ICE_CLK pin.
67	PD.9/EBI_AD7/UART2_nCTS/PSIO0_CH2

68	PD.8/EBI_AD6/UART2_nRTS/PSIO0_CH3
69	PC.5/EBI_AD5/QSPI0_MISO1/UART2_TXD/I2C1_SCL/PWM1_CH0/PSIO0_CH0
70	PC.4/EBI_AD4/QSPI0_MOSI1/UART2_RXD/I2C1_SDA/PWM1_CH1/USCI2_CTL1/PSIO0_CH1
71	PC.3/EBI_AD3/QSPI0_SS/UART2_nRTS/I2C0_SMBAL/PWM1_CH2/USCI2_CTL0/PSIO0_CH2
72	PC.2/EBI_AD2/QSPI0_CLK/UART2_nCTS/I2C0_SMBUS/PWM1_CH3/USCI2_CLK/PSIO0_CH3
73	PC.1/EBI_AD1/QSPI0_MISO0/UART2_TXD/I2C0_SCL/PWM1_CH4/USCI2_DAT0/ACMP0_O
74	PC.0/EBI_AD0/QSPI0_MOSI0/UART2_RXD/I2C0_SDA/PWM1_CH5/USCI2_DAT1/ACMP1_O
75	V <sub>SS</sub>
76	V <sub>DD</sub>
77	NC
78	NC
79	NC
80	NC
81	NC
82	NC
83	NC
84	PD.7/UART1_TXD/I2C0_SCL/USCI1_CLK/PSIO0_CH4
85	PD.6/UART1_RXD/I2C0_SDA/USCI1_DAT1/PSIO0_CH5
86	PD.5/I2C1_SCL/USCI1_DAT0/PSIO0_CH6
87	PD.4/USCI0_CTL0/I2C1_SDA/USCI1_CTL1/PSIO0_CH7
88	PD.3/EBI_AD10/USCI0_CTL1/SPI0_SS/USCI1_CTL0/UART0_TXD
89	PD.2/EBI_AD11/USCI0_DAT1/SPI0_CLK/UART0_RXD
90	PD.1/EBI_AD12/USCI0_DAT0/SPI0_MISO
91	PD.0/EBI_AD13/USCI0_CLK/SPI0_MOSI/TM2
92	PD.13/EBI_AD10/SPI0_I2SMCLK/USCI2_CTL0
93	USB_VBUS
94	USB_D-
95	USB_D+
96	USB_VDD33_CAP
97	PE.7/PSIO0_CH0/PWM0_CH0/BPWM0_CH5
98	PE.6/SC0_nCD/USCI0_CTL0/PSIO0_CH1/PWM0_CH1/BPWM0_CH4
99	PE.5/EBI_nRD/SC0_PWR/USCI0_CTL1/PSIO0_CH2/PWM0_CH2/BPWM0_CH3
100	PE.4/EBI_nWR/SC0_RST/USCI0_DAT1/PSIO0_CH3/PWM0_CH3/BPWM0_CH2
101	PE.3/EBI_MCLK/SC0_DAT/USCI0_DAT0/PWM0_CH4/BPWM0_CH1
102	PE.2/EBI_ALE/SC0_CLK/USCI0_CLK/USCI2_CTL0/PWM0_CH5/BPWM0_CH0
103	NC

104	NC
105	PE.1/EBI_AD10/QSPI0_MISO0/I2C1_SCL/USCI2_DAT1
106	PE.0/EBI_AD11/QSPI0_MOSI0/I2C1_SDA/USCI2_DAT0
107	NC
108	NC
109	NC
110	NC
111	NC
112	V <sub>SS</sub>
113	LDO_CAP
114	V <sub>DD</sub>
115	PC.14/EBI_AD11/SPI0_I2SMCLK/USCI0_CTL0/QSPI0_CLK/USCI2_CLK/TM1
116	PB.15/EADC0_CH15/EBI_AD12/SPI0_SS/USCI0_CTL1/UART0_nCTS/PSIO0_CH0/PWM1_CH0/TM0_EXT/PWM0_BRAKE1
117	PB.14/EADC0_CH14/EBI_AD13/SPI0_CLK/USCI0_DAT1/UART0_nRTS/PSIO0_CH1/PWM1_CH1/TM1_EXT/CLKO
118	PB.13/EADC0_CH13/ACMP0_P3/ACMP1_P3/EBI_AD14/SPI0_MISO/USCI0_DAT0/UART0_TXD/PSIO0_CH2/PWM1_CH2/TM2_EXT
119	PB.12/EADC0_CH12/ACMP0_P2/ACMP1_P2/EBI_AD15/SPI0_MOSI/USCI0_CLK/UART0_RXD/PSIO0_CH3/PWM1_CH3/TM3_EXT
120	AV <sub>DD</sub>
121	V <sub>REF</sub>
122	AV <sub>SS</sub>
123	PB.11/EADC0_CH11/EBI_ADR16/UART0_nCTS/I2C1_SCL/SPI0_I2SMCLK/BPWM1_CH0
124	PB.10/EADC0_CH10/EBI_ADR17/USCI1_CTL0/UART0_nRTS/I2C1_SDA/BPWM1_CH1
125	PB.9/EADC0_CH9/EBI_ADR18/USCI1_CTL1/UART0_TXD/UART1_nCTS/I2C1_SMBAL/BPWM1_CH2
126	PB.8/EADC0_CH8/EBI_ADR19/USCI1_CLK/UART0_RXD/UART1_nRTS/I2C1_SMBSUS/BPWM1_CH3
127	PB.7/EADC0_CH7/EBI_nWRL/USCI1_DAT0/UART1_TXD/EBI_nCS0/BPWM1_CH4/PWM1_BRAKE0/PWM1_CH4/INT5/ACMP0_O
128	PB.6/EADC0_CH6/EBI_nWRH/USCI1_DAT1/UART1_RXD/EBI_nCS1/BPWM1_CH5/PWM1_BRAKE1/PWM1_CH5/INT4/ACMP1_O

Table 4.1-23 M252KE3AE Multi-function Pin Table

M252KG6AE

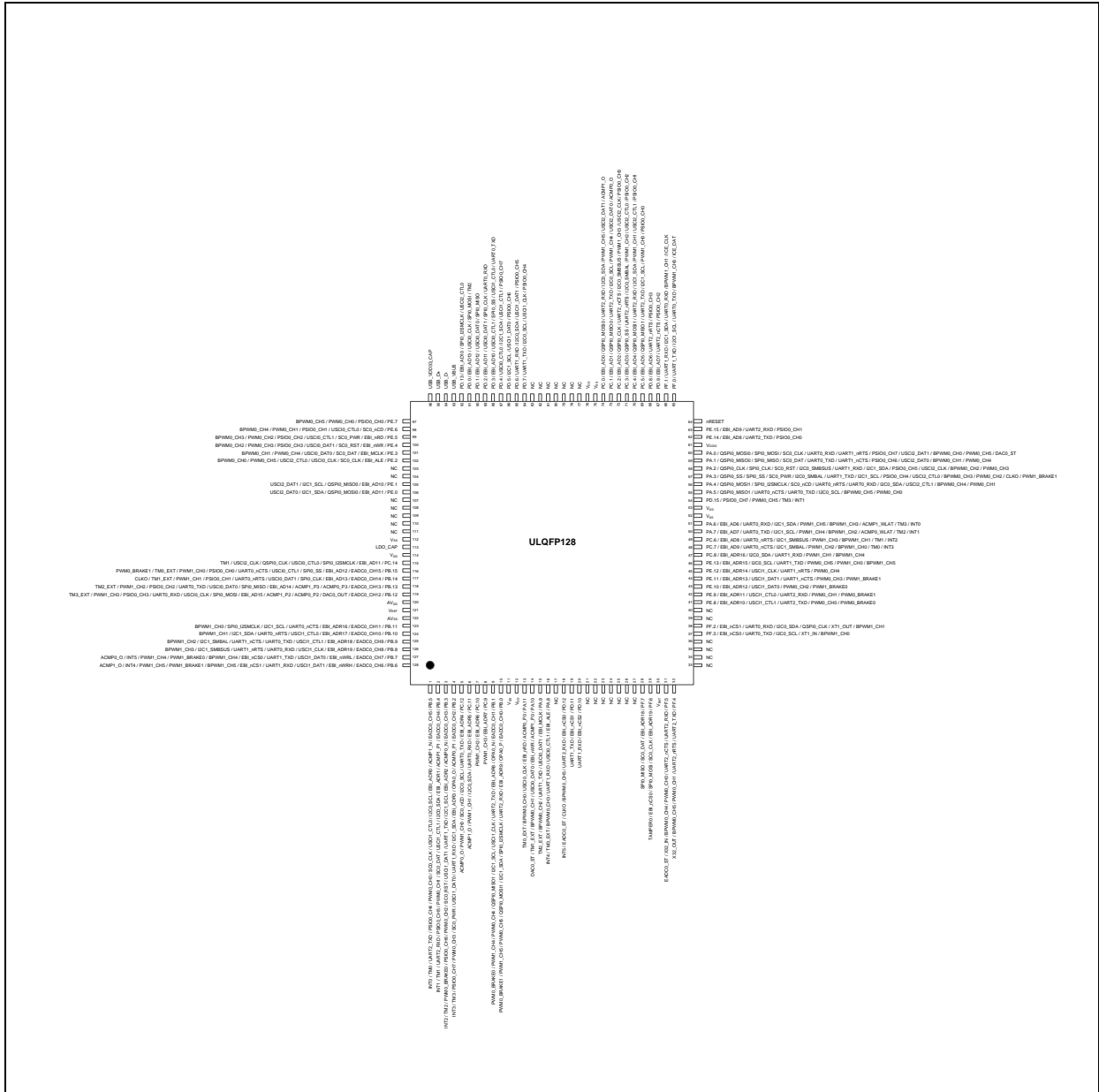

Figure 4.1-38 M252KG6AE Function Pin Diagram

Pin	M252KG6AE Pin Function
1	PB.5/EADC0_CH5/ACMP1_N/EBI_ADR0/I2C0_SCL/USC1_CTL0/SC0_CLK/PWM0_CH0/PSIO0_CH4/UART2_TXD/TM0/INT0
2	PB.4/EADC0_CH4/ACMP1_P1/EBI_ADR1/I2C0_SDA/USC1_CTL1/SC0_DAT/PWM0_CH1/PSIO0_CH5/UART2_RXD/TM1/INT1
3	PB.3/EADC0_CH3/ACMP0_N/EBI_ADR2/I2C1_SCL/UART1_TXD/USC1_DAT1/SC0_RST/PWM0_CH2/PSIO0_CH6/PWM0_BRAKE0/TM2/INT2
4	PB.2/EADC0_CH2/ACMP0_P1/OPA0_O/EBI_ADR3/I2C1_SDA/UART1_RXD/USC1_DAT0/SC0_PWR/PWM0_CH3/PSIO0_CH7/TM3/INT3

5	PC.12/EBI_ADR4/UART0_TXD/I2C0_SCL/SC0_nCD/PWM1_CH0/ACMP0_O
6	PC.11/EBI_ADR5/UART0_RXD/I2C0_SDA/PWM1_CH1/ACMP1_O
7	PC.10/EBI_ADR6/PWM1_CH2
8	PC.9/EBI_ADR7/PWM1_CH3
9	PB.1/EADC0_CH1/OPA0_N/EBI_ADR8/UART2_TXD/USCI1_CLK/I2C1_SCL/QSPI0_MISO1/PWM0_CH4/PWM1_CH4/PWM0_BRAKE0
10	PB.0/EADC0_CH0/OPA0_P/EBI_ADR9/UART2_RXD/SPI0_I2SMCLK/I2C1_SDA/QSPI0_MOSI1/PWM0_CH5/PWM1_CH5/PWM0_BRAKE1
11	V <sub>SS</sub>
12	V <sub>DD</sub>
13	PA.11/ACMP0_P0/EBI_nRD/USCI0_CLK/BPWM0_CH0/TM0_EXT
14	PA.10/ACMP1_P0/EBI_nWR/USCI0_DAT0/BPWM0_CH1/TM1_EXT/DAC0_ST
15	PA.9/EBI_MCLK/USCI0_DAT1/UART1_TXD/BPWM0_CH2/TM2_EXT
16	PA.8/EBI_ALE/USCI0_CTL1/UART1_RXD/BPWM0_CH3/TM3_EXT/INT4
17	NC
18	PD.12/EBI_nCS0/UART2_RXD/BPWM0_CH5/CLKO/EADC0_ST/INT5
19	PD.11/EBI_nCS1/UART1_TXD
20	PD.10/EBI_nCS2/UART1_RXD
21	NC
22	NC
23	NC
24	NC
25	NC
26	NC
27	NC
28	PF.7/EBI_ADR18/SC0_DAT/SPI0_MISO
29	PF.6/EBI_ADR19/SC0_CLK/SPI0_MOSI/EBI_nCS0/TAMPER0
30	V <sub>BAT</sub>
31	PF.5/UART2_RXD/UART2_nCTS/PWM0_CH0/BPWM0_CH4/X32_IN/EADC0_ST
32	PF.4/UART2_TXD/UART2_nRTS/PWM0_CH1/BPWM0_CH5/X32_OUT
33	NC
34	NC
35	NC
36	NC
37	PF.3/EBI_nCS0/UART0_TXD/I2C0_SCL/XT1_IN/BPWM1_CH0
38	PF.2/EBI_nCS1/UART0_RXD/I2C0_SDA/QSPI0_CLK/XT1_OUT/BPWM1_CH1
39	NC

40	NC
41	PE.8/EBI_ADR10/USCI1_CTL1/UART2_TXD/PWM0_CH0/PWM0_BRAKE0
42	PE.9/EBI_ADR11/USCI1_CTL0/UART2_RXD/PWM0_CH1/PWM0_BRAKE1
43	PE.10/EBI_ADR12/USCI1_DAT0/PWM0_CH2/PWM1_BRAKE0
44	PE.11/EBI_ADR13/USCI1_DAT1/UART1_nCTS/PWM0_CH3/PWM1_BRAKE1
45	PE.12/EBI_ADR14/USCI1_CLK/UART1_nRTS/PWM0_CH4
46	PE.13/EBI_ADR15/I2C0_SCL/UART1_TXD/PWM0_CH5/PWM1_CH0/BPWM1_CH5
47	PC.8/EBI_ADR16/I2C0_SDA/UART1_RXD/PWM1_CH1/BPWM1_CH4
48	PC.7/EBI_AD9/UART0_nCTS/I2C1_SMBAL/PWM1_CH2/BPWM1_CH0/TM0/INT3
49	PC.6/EBI_AD8/UART0_nRTS/I2C1_SMBSUS/PWM1_CH3/BPWM1_CH1/TM1/INT2
50	PA.7/EBI_AD7/UART0_TXD/I2C1_SCL/PWM1_CH4/BPWM1_CH2/ACMP0_WLAT/TM2/INT1
51	PA.6/EBI_AD6/UART0_RXD/I2C1_SDA/PWM1_CH5/BPWM1_CH3/ACMP1_WLAT/TM3/INT0
52	V <sub>SS</sub>
53	V <sub>DD</sub>
54	PD.15/PSIO0_CH7/PWM0_CH5/TM3/INT1
55	PA.5/QSPI0_MISO1/UART0_nCTS/UART0_TXD/I2C0_SCL/BPWM0_CH5/PWM0_CH0
56	PA.4/QSPI0_MOSI1/SPI0_I2SMCLK/SC0_nCD/UART0_nRTS/UART0_RXD/I2C0_SDA/USCI2_CTL1/BPWM0_CH4/PWM0_CH1
57	PA.3/QSPI0_SS/SPI0_SS/SC0_PWR/I2C0_SMBAL/UART1_TXD/I2C1_SCL/PSIO0_CH4/USCI2_CTL0/BPWM0_CH3/PWM0_CH2/CLKO/PWM1_BRAKE1
58	PA.2/QSPI0_CLK/SPI0_CLK/SC0_RST/I2C0_SMBSUS/UART1_RXD/I2C1_SDA/PSIO0_CH5/USCI2_CLK/BPWM0_CH2/PWM0_CH3
59	PA.1/QSPI0_MISO0/SPI0_MISO/SC0_DAT/UART0_TXD/UART1_nCTS/PSIO0_CH6/USCI2_DAT0/BPWM0_CH1/PWM0_CH4
60	PA.0/QSPI0_MOSI0/SPI0_MOSI/SC0_CLK/UART0_RXD/UART1_nRTS/PSIO0_CH7/USCI2_DAT1/BPWM0_CH0/PWM0_CH5/DAC0_ST
61	V <sub>DDIO</sub>
62	PE.14/EBI_AD8/UART2_TXD/PSIO0_CH0
63	PE.15/EBI_AD9/UART2_RXD/PSIO0_CH1
64	nRESET <b>Note:</b> It is recommended to use 10 kΩ pull-up resistor and 10 uF capacitor on nRESET pin.
65	PF.0/UART1_TXD/I2C1_SCL/UART0_TXD/BPWM1_CH0/ICE_DAT <b>Note:</b> It is recommended to use 100 kΩ pull-up resistor on ICE_DAT pin.
66	PF.1/UART1_RXD/I2C1_SDA/UART0_RXD/BPWM1_CH1/ICE_CLK <b>Note:</b> It is recommended to use 100 kΩ pull-up resistor on ICE_CLK pin.
67	PD.9/EBI_AD7/UART2_nCTS/PSIO0_CH2
68	PD.8/EBI_AD6/UART2_nRTS/PSIO0_CH3
69	PC.5/EBI_AD5/QSPI0_MISO1/UART2_TXD/I2C1_SCL/PWM1_CH0/PSIO0_CH0
70	PC.4/EBI_AD4/QSPI0_MOSI1/UART2_RXD/I2C1_SDA/PWM1_CH1/USCI2_CTL1/PSIO0_CH1

71	PC.3/EBI_AD3/QSPI0_SS/UART2_nRTS/I2C0_SMBAL/PWM1_CH2/USCI2_CTL0/PSIO0_CH2
72	PC.2/EBI_AD2/QSPI0_CLK/UART2_nCTS/I2C0_SMBUS/PWM1_CH3/USCI2_CLK/PSIO0_CH3
73	PC.1/EBI_AD1/QSPI0_MISO0/UART2_TXD/I2C0_SCL/PWM1_CH4/USCI2_DAT0/ACMP0_O
74	PC.0/EBI_AD0/QSPI0_MOSI0/UART2_RXD/I2C0_SDA/PWM1_CH5/USCI2_DAT1/ACMP1_O
75	V <sub>SS</sub>
76	V <sub>DD</sub>
77	NC
78	NC
79	NC
80	NC
81	NC
82	NC
83	NC
84	PD.7/UART1_TXD/I2C0_SCL/USCI1_CLK/PSIO0_CH4
85	PD.6/UART1_RXD/I2C0_SDA/USCI1_DAT1/PSIO0_CH5
86	PD.5/I2C1_SCL/USCI1_DAT0/PSIO0_CH6
87	PD.4/USCI0_CTL0/I2C1_SDA/USCI1_CTL1/PSIO0_CH7
88	PD.3/EBI_AD10/USCI0_CTL1/SPI0_SS/USCI1_CTL0/UART0_TXD
89	PD.2/EBI_AD11/USCI0_DAT1/SPI0_CLK/UART0_RXD
90	PD.1/EBI_AD12/USCI0_DAT0/SPI0_MISO
91	PD.0/EBI_AD13/USCI0_CLK/SPI0_MOSI/TM2
92	PD.13/EBI_AD10/SPI0_I2SMCLK/USCI2_CTL0
93	USB_VBUS
94	USB_D-
95	USB_D+
96	USB_VDD33_CAP
97	PE.7/PSIO0_CH0/PWM0_CH0/BPWM0_CH5
98	PE.6/SC0_nCD/USCI0_CTL0/PSIO0_CH1/PWM0_CH1/BPWM0_CH4
99	PE.5/EBI_nRD/SC0_PWR/USCI0_CTL1/PSIO0_CH2/PWM0_CH2/BPWM0_CH3
100	PE.4/EBI_nWR/SC0_RST/USCI0_DAT1/PSIO0_CH3/PWM0_CH3/BPWM0_CH2
101	PE.3/EBI_MCLK/SC0_DAT/USCI0_DAT0/PWM0_CH4/BPWM0_CH1
102	PE.2/EBI_ALE/SC0_CLK/USCI0_CLK/USCI2_CTL0/PWM0_CH5/BPWM0_CH0
103	NC
104	NC
105	PE.1/EBI_AD10/QSPI0_MISO0/I2C1_SCL/USCI2_DAT1
106	PE.0/EBI_AD11/QSPI0_MOSI0/I2C1_SDA/USCI2_DAT0

107	NC
108	NC
109	NC
110	NC
111	NC
112	V <sub>SS</sub>
113	LDO_CAP
114	V <sub>DD</sub>
115	PC.14/EBI_AD11/SPI0_I2SMCLK/USCI0_CTL0/QSPI0_CLK/USCI2_CLK/TM1
116	PB.15/EADC0_CH15/EBI_AD12/SPI0_SS/USCI0_CTL1/UART0_nCTS/PSIO0_CH0/PWM1_CH0/TM0_EXT/PWM0_BRAKE1
117	PB.14/EADC0_CH14/EBI_AD13/SPI0_CLK/USCI0_DAT1/UART0_nRTS/PSIO0_CH1/PWM1_CH1/TM1_EXT/CLKO
118	PB.13/EADC0_CH13/ACMP0_P3/ACMP1_P3/EBI_AD14/SPI0_MISO/USCI0_DAT0/UART0_TXD/PSIO0_CH2/PWM1_CH2/TM2_EXT
119	PB.12/EADC0_CH12/DAC0_OUT/ACMP0_P2/ACMP1_P2/EBI_AD15/SPI0_MOSI/USCI0_CLK/UART0_RXD/PSIO0_CH3/PWM1_CH3/TM3_EXT
120	AV <sub>DD</sub>
121	V <sub>REF</sub>
122	AV <sub>SS</sub>
123	PB.11/EADC0_CH11/EBI_ADR16/UART0_nCTS/I2C1_SCL/SPI0_I2SMCLK/BPWM1_CH0
124	PB.10/EADC0_CH10/EBI_ADR17/USCI1_CTL0/UART0_nRTS/I2C1_SDA/BPWM1_CH1
125	PB.9/EADC0_CH9/EBI_ADR18/USCI1_CTL1/UART0_TXD/UART1_nCTS/I2C1_SMBAL/BPWM1_CH2
126	PB.8/EADC0_CH8/EBI_ADR19/USCI1_CLK/UART0_RXD/UART1_nRTS/I2C1_SMBSUS/BPWM1_CH3
127	PB.7/EADC0_CH7/EBI_nWRL/USCI1_DAT0/UART1_TXD/EBI_nCS0/BPWM1_CH4/PWM1_BRAKE0/PWM1_CH4/INT5/ACMP0_O
128	PB.6/EADC0_CH6/EBI_nWRH/USCI1_DAT1/UART1_RXD/EBI_nCS1/BPWM1_CH5/PWM1_BRAKE1/PWM1_CH5/INT4/ACMP1_O

Table 4.1-24 M252KG6AE Multi-function Pin Table

### 4.2 Pin Mapping

Different part number with same package might has different function. Please refer to the selection guide in section 3.2, Pin Configuration in section 4.1 or [NuTool - PinConfig](#).

Corresponding Part Number: M251/M252 Series

#### M251/M252 Series Pin Mapping

Pin Name	M251 Series						M252 Series					
	20 Pin	28 Pin	32 Pin	48 Pin	64 Pin	128 Pin	20 Pin	28 Pin	32 Pin	48 Pin	64 Pin	128 Pin
PB.5	8	12	1	1	2	1		12	1	1	2	1
PB.4	9	13	2	2	3	2		13	2	2	3	2
PB.3	10	14	3	3	4	3		14	3	3	4	3
PB.2	11	15	4	4	5	4		15	4	4	5	4
PC.12						5						5
PC.11						6						6
PC.10						7						7
PC.9						8						8
PB.1		16	5	5	6	9		16	5	5	6	9
PB.0		17	6	6	7	10		17	6	6	7	10
V <sub>SS</sub>						11						11
V <sub>DD</sub>						12						12
PA.11				7	8	13				7	8	13
PA.10				8	9	14				8	9	14
PA.9				9	10	15				9	10	15
PA.8				10	11	16				10	11	16
NC						17						17
PD.12						18						18
PD.11						19						19
PD.10						20						20
NC						21						21
NC						22						22
NC						23						23
NC						24						24
NC						25						25
NC						26						26
NC						27						27
PF.7						28						28
PF.6					12	29					12	29

Pin Name	M251 Series						M252 Series					
	20 Pin	28 Pin	32 Pin	48 Pin	64 Pin	128 Pin	20 Pin	28 Pin	32 Pin	48 Pin	64 Pin	128 Pin
PF.14 or V <sub>BAT</sub>					13						13	
V <sub>BAT</sub>						30						30
PF.5			7	11	14	31			7	11	14	31
PF.4			8	12	15	32			8	12	15	32
NC						33						33
NC						34						34
NC						35						35
NC						36						36
PF.3	12	18	9	13	16	37	11	18	9	13	16	37
PF.2	13	19	10	14	17	38	12	19	10	14	17	38
NC						39						39
NC						40						40
PE.8						41						41
PE.9						42						42
PE.10						43						43
PE.11						44						44
PE.12						45						45
PE.13						46						46
PC.8						47						47
PC.7					18	48					18	48
PC.6					19	49					19	49
PA.7				15	20	50				15	20	50
PA.6				16	21	51				16	21	51
V <sub>SS</sub>					22	52					22	52
V <sub>DD</sub>					23	53					23	53
PD.15					24	54					24	54
PA.5				17	25	55				17	25	55
PA.4				18	26	56				18	26	56
PA.3	14	20	11	19	27	57	13	20	11	19	27	57
PA.2	15	21	12	20	28	58	14	21	12	20	28	58
PA.1	16	22	13	21	29	59	15	22	13	21	29	59
PA.0	17	23	14	22	30	60	16	23	14	22	30	60
V <sub>DDIO</sub>			15	23	31	61			15	23	31	61
PE.14						62						62

Pin Name	M251 Series						M252 Series					
	20 Pin	28 Pin	32 Pin	48 Pin	64 Pin	128 Pin	20 Pin	28 Pin	32 Pin	48 Pin	64 Pin	128 Pin
PE.15						63						63
nRESET	18	24	16	24	32	64	17	24	16	24	32	64
PF.0	19	25	17	25	33	65	18	25	17	25	33	65
ICE_DAT												
PF.1	20	26	18	26	34	66	19	26	18	26	34	66
ICE_CLK												
PD.9						67						67
PD.8						68						68
PC.5				27	35	69				27	35	69
PC.4				28	36	70				28	36	70
PC.3				29	37	71				29	37	71
PC.2				30	38	72				30	38	72
PC.1		27	19	31	39	73		27	19	31	39	73
PC.0		28	20	32	40	74		28	20	32	40	74
V <sub>SS</sub>						75						75
V <sub>DD</sub>						76						76
NC						77						77
NC						78						78
NC						79						79
NC						80						80
NC						81						81
NC						82						82
NC						83						83
PD.7						84						84
PD.6						85						85
PD.5						86						86
PD.4						87						87
PD.3					41	88					41	88
PD.2					42	89					42	89
PD.1					43	90					43	90
PD.0					44	91					44	91
PD.13						92						92
PA.12		1	21	33	45	93						
PA.13		2	22	34	46	94						

Pin Name	M251 Series						M252 Series					
	20 Pin	28 Pin	32 Pin	48 Pin	64 Pin	128 Pin	20 Pin	28 Pin	32 Pin	48 Pin	64 Pin	128 Pin
PA.14		3	23	35	47	95						
PA.15		4	24	36	48	96						
USB_VBUS							20	1	21	33	45	93
USB_D-							1	2	22	34	46	94
USB_D+							2	3	23	35	47	95
USB_V <sub>DD33</sub> _CAP							3	4	24	36	48	96
PE.7						97						97
PE.6						98						98
PE.5						99						99
PE.4						100						100
PE.3						101						101
PE.2						102						102
NC						103						103
NC						104						104
PE.1						105						105
PE.0						106						106
NC						107						107
NC						108						108
NC						109						109
NC						110						110
NC						111						111
V <sub>SS</sub>	1	5	25	37	49	112	4	5	25	37	49	112
LDO_CAP	2	6	26	38	50	113	5	6	26	38	50	113
V <sub>DD</sub>	3	7	27	39	51	114	6	7	27	39	51	114
PC.14				40	52	115				40	52	115
PB.15			28	41	53	116			28	41	53	116
PB.14	4	8	29	42	54	117	7	8	29	42	54	117
PB.13	5	9	30	43	55	118	8	9	30	43	55	118
PB.12	6	10	31	44	56	119	9	10	31	44	56	119
AV <sub>DD</sub>	7	11	32	45	57	120	10	11	32	45	57	120
V <sub>REF</sub>					58	121					58	121
AV <sub>SS</sub>				46	59	122				46	59	122
PB.11					60	123					60	123
PB.10					61	124					61	124

Pin Name	M251 Series						M252 Series					
	20 Pin	28 Pin	32 Pin	48 Pin	64 Pin	128 Pin	20 Pin	28 Pin	32 Pin	48 Pin	64 Pin	128 Pin
PB.9					62	125					62	125
PB.8					63	126					63	126
PB.7				47	64	127				47	64	127
PB.6				48	1	128				48	1	128

### 4.3 Pin Function Description

Group	Pin Name	Type	Description
ACMP0	ACMP0_N	A	Analog comparator 0 negative input pin.
	ACMP0_O	O	Analog comparator 0 output pin.
	ACMP0_P0	A	Analog comparator 0 positive input 0 pin.
	ACMP0_P1	A	Analog comparator 0 positive input 1 pin.
	ACMP0_P2	A	Analog comparator 0 positive input 2 pin.
	ACMP0_P3	A	Analog comparator 0 positive input 3 pin.
	ACMP0_WLAT	I	Analog comparator 0 window latch input pin
ACMP1	ACMP1_N	A	Analog comparator 1 negative input pin.
	ACMP1_O	O	Analog comparator 1 output pin.
	ACMP1_P0	A	Analog comparator 1 positive input 0 pin.
	ACMP1_P1	A	Analog comparator 1 positive input 1 pin.
	ACMP1_P2	A	Analog comparator 1 positive input 2 pin.
	ACMP1_P3	A	Analog comparator 1 positive input 3 pin.
	ACMP1_WLAT	I	Analog comparator 1 window latch input pin
BPWM0	BPWM0_CH0	I/O	BPWM0 channel 0 output/capture input.
	BPWM0_CH1	I/O	BPWM0 channel 1 output/capture input.
	BPWM0_CH2	I/O	BPWM0 channel 2 output/capture input.
	BPWM0_CH3	I/O	BPWM0 channel 3 output/capture input.
	BPWM0_CH4	I/O	BPWM0 channel 4 output/capture input.
	BPWM0_CH5	I/O	BPWM0 channel 5 output/capture input.
BPWM1	BPWM1_CH0	I/O	BPWM1 channel 0 output/capture input.
	BPWM1_CH1	I/O	BPWM1 channel 1 output/capture input.
	BPWM1_CH2	I/O	BPWM1 channel 2 output/capture input.
	BPWM1_CH3	I/O	BPWM1 channel 3 output/capture input.
	BPWM1_CH4	I/O	BPWM1 channel 4 output/capture input.
	BPWM1_CH5	I/O	BPWM1 channel 5 output/capture input.
CLKO	CLKO	O	Clock Out
DAC0	DAC0_OUT	A	DAC0 channel analog output.
	DAC0_ST	I	DAC0 external trigger input.
EADC0	EADC0_CH0	A	EADC0 channel 0 analog input.
	EADC0_CH1	A	EADC0 channel 1 analog input.
	EADC0_CH2	A	EADC0 channel 2 analog input.
	EADC0_CH3	A	EADC0 channel 3 analog input.
	EADC0_CH4	A	EADC0 channel 4 analog input.

Group	Pin Name	Type	Description
	EADC0_CH5	A	EADC0 channel 5 analog input.
	EADC0_CH6	A	EADC0 channel 6 analog input.
	EADC0_CH7	A	EADC0 channel 7 analog input.
	EADC0_CH8	A	EADC0 channel 8 analog input.
	EADC0_CH9	A	EADC0 channel 9 analog input.
	EADC0_CH10	A	EADC0 channel 10 analog input.
	EADC0_CH11	A	EADC0 channel 11 analog input.
	EADC0_CH12	A	EADC0 channel 12 analog input.
	EADC0_CH13	A	EADC0 channel 13 analog input.
	EADC0_CH14	A	EADC0 channel 14 analog input.
	EADC0_CH15	A	EADC0 channel 15 analog input.
	EADC0_ST	I	EADC0 external trigger input.
EBI	EBI_AD0	I/O	EBI address/data bus bit 0.
	EBI_AD1	I/O	EBI address/data bus bit 1.
	EBI_AD2	I/O	EBI address/data bus bit 2.
	EBI_AD3	I/O	EBI address/data bus bit 3.
	EBI_AD4	I/O	EBI address/data bus bit 4.
	EBI_AD5	I/O	EBI address/data bus bit 5.
	EBI_AD6	I/O	EBI address/data bus bit 6.
	EBI_AD7	I/O	EBI address/data bus bit 7.
	EBI_AD8	I/O	EBI address/data bus bit 8.
	EBI_AD9	I/O	EBI address/data bus bit 9.
	EBI_AD10	I/O	EBI address/data bus bit 10.
	EBI_AD11	I/O	EBI address/data bus bit 11.
	EBI_AD12	I/O	EBI address/data bus bit 12.
	EBI_AD13	I/O	EBI address/data bus bit 13.
	EBI_AD14	I/O	EBI address/data bus bit 14.
	EBI_AD15	I/O	EBI address/data bus bit 15.
	EBI_ADR0	O	EBI address bus bit 0.
	EBI_ADR1	O	EBI address bus bit 1.
	EBI_ADR2	O	EBI address bus bit 2.
	EBI_ADR3	O	EBI address bus bit 3.
	EBI_ADR4	O	EBI address bus bit 4.
	EBI_ADR5	O	EBI address bus bit 5.
	EBI_ADR6	O	EBI address bus bit 6.

Group	Pin Name	Type	Description
	EBI_ADR7	O	EBI address bus bit 7.
	EBI_ADR8	O	EBI address bus bit 8.
	EBI_ADR9	O	EBI address bus bit 9.
	EBI_ADR10	O	EBI address bus bit 10.
	EBI_ADR11	O	EBI address bus bit 11.
	EBI_ADR12	O	EBI address bus bit 12.
	EBI_ADR13	O	EBI address bus bit 13.
	EBI_ADR14	O	EBI address bus bit 14.
	EBI_ADR15	O	EBI address bus bit 15.
	EBI_ADR16	O	EBI address bus bit 16.
	EBI_ADR17	O	EBI address bus bit 17.
	EBI_ADR18	O	EBI address bus bit 18.
	EBI_ADR19	O	EBI address bus bit 19.
	EBI_ALE	O	EBI address latch enable output pin.
	EBI_MCLK	O	EBI external clock output pin.
	EBI_nCS0	O	EBI chip select 0 output pin.
	EBI_nCS1	O	EBI chip select 1 output pin.
	EBI_nCS2	O	EBI chip select 2 output pin.
	EBI_nRD	O	EBI read enable output pin.
	EBI_nWR	O	EBI write enable output pin.
EBI_nWRH	O	EBI high byte write enable output pin	
EBI_nWRL	O	EBI low byte write enable output pin.	
GPIO	PA.x~PH.x	I/O	General purpose digital I/O pin.
I2C0	I2C0_SCL	I/O	I2C0 clock pin.
	I2C0_SDA	I/O	I2C0 data input/output pin.
	I2C0_SMBAL	O	I2C0 SMBus SMBALTER pin
	I2C0_SMBSUS	O	I2C0 SMBus SMBSUS pin (PMBus CONTROL pin)
I2C1	I2C1_SCL	I/O	I2C1 clock pin.
	I2C1_SDA	I/O	I2C1 data input/output pin.
	I2C1_SMBAL	O	I2C1 SMBus SMBALTER pin
	I2C1_SMBSUS	O	I2C1 SMBus SMBSUS pin (PMBus CONTROL pin)
ICE	ICE_CLK	I/O	Serial wired debugger clock pin <b>Note:</b> It is recommended to use 100 kΩ pull-up resistor on ICE_CLK pin.
	ICE_DAT	I/O	Serial wired debugger data pin <b>Note:</b> It is recommended to use 100 kΩ pull-up resistor on ICE_DAT pin.
	nRESET	I	External reset input: active LOW, with an internal pull-up. Set this pin low reset to initial state. <b>Note:</b> It is recommended to use 10 kΩ pull-up resistor and 10 uF capacitor on nRESET pin.

Group	Pin Name	Type	Description
INT0	INT0	I	External interrupt 0 input pin.
INT1	INT1	I	External interrupt 1 input pin.
INT3	INT3	I	External interrupt 3 input pin.
INT4	INT4	I	External interrupt 4 input pin.
INT5	INT5	I	External interrupt 5 input pin.
OPA0	OPA0_N	A	Operational amplifier 0 negative input pin.
	OPA0_O	A	Operational amplifier 0 output pin.
	OPA0_P	A	Operational amplifier 0 positive input pin.
PSIO0	PSIO0_CH0	I/O	PSIO 0 channel 0 input/output pin.
	PSIO1_CH0	I/O	PSIO 0 channel 1 input/output pin.
	PSIO2_CH0	I/O	PSIO 0 channel 2 input/output pin.
	PSIO3_CH0	I/O	PSIO 0 channel 3 input/output pin.
	PSIO4_CH0	I/O	PSIO 0 channel 4 input/output pin.
	PSIO5_CH0	I/O	PSIO 0 channel 5 input/output pin.
	PSIO6_CH0	I/O	PSIO 0 channel 6 input/output pin.
	PSIO7_CH0	I/O	PSIO 0 channel 7 input/output pin.
CLKO	CLKO	O	Clock Out
PWM0	PWM0_BRAKE0	I	PWM0 Brake 0 input pin.
	PWM0_BRAKE1	I	PWM0 Brake 1 input pin.
	PWM0_CH0	I/O	PWM0 channel 0 output/capture input.
	PWM0_CH1	I/O	PWM0 channel 1 output/capture input.
	PWM0_CH2	I/O	PWM0 channel 2 output/capture input.
	PWM0_CH3	I/O	PWM0 channel 3 output/capture input.
	PWM0_CH4	I/O	PWM0 channel 4 output/capture input.
	PWM0_CH5	I/O	PWM0 channel 5 output/capture input.
PWM1	PWM1_BRAKE0	I	PWM1 Brake 0 input pin.
	PWM1_BRAKE1	I	PWM1 Brake 1 input pin.
	PWM1_CH0	I/O	PWM1 channel 0 output/capture input.
	PWM1_CH1	I/O	PWM1 channel 1 output/capture input.
	PWM1_CH2	I/O	PWM1 channel 2 output/capture input.
	PWM1_CH3	I/O	PWM1 channel 3 output/capture input.
	PWM1_CH4	I/O	PWM1 channel 4 output/capture input.
	PWM1_CH5	I/O	PWM1 channel 5 output/capture input.
Power	V <sub>DD</sub>	P	Power supply for I/O ports and LDO source for internal PLL and digital circuit.
	V <sub>SS</sub>	P	Ground pin for digital circuit.

Group	Pin Name	Type	Description
	V <sub>DDIO</sub>	P	Power supply for PA.0~PA.5.
	V <sub>BAT</sub>	P	Power supply by batteries for RTC.
	AV <sub>DD</sub>	P	Power supply for internal analog circuit.
	AV <sub>SS</sub>	P	Ground pin for analog circuit.
	V <sub>REF</sub>	A	ADC reference voltage input. <b>Note:</b> This pin needs to be connected with a 1uF capacitor.
	LDO_CAP	A	LDO output pin. <b>Note:</b> This pin needs to be connected with a 1uF capacitor.
QSPI0	QSPI0_CLK	I/O	Quad SPI0 serial clock pin.
	QSPI0_MISO0	I/O	Quad SPI0 MISO0 (Master In, Slave Out) pin.
	QSPI0_MISO1	I/O	Quad SPI0 MISO1 (Master In, Slave Out) pin.
	QSPI0_MOSI0	I/O	Quad SPI0 MOSI0 (Master Out, Slave In) pin.
	QSPI0_MOSI1	I/O	Quad SPI0 MOSI1 (Master Out, Slave In) pin.
	QSPI0_SS	I/O	Quad SPI0 slave select pin.
SC0	SC0_CLK	O	Smart Card 0 clock pin.
	SC0_DAT	I/O	Smart Card 0 data pin.
	SC0_PWR	O	Smart Card 0 power pin.
	SC0_RST	O	Smart Card 0 reset pin.
	SC0_nCD	I	Smart Card 0 card detect pin.
SPI0	SPI0_CLK	I/O	SPI0 serial clock pin.
	SPI0_I2SMCLK	I/O	SPI0 I <sup>2</sup> S master clock output pin
	SPI0_MISO	I/O	SPI0 MISO (Master In, Slave Out) pin.
	SPI0_MOSI	I/O	SPI0 MOSI (Master Out, Slave In) pin.
	SPI0_SS	I/O	SPI0 slave select pin.
TAMPER0	TAMPER0	I/O	TAMPER detector loop pin 0.
TM0	TM0	I/O	Timer0 event counter input/toggle output pin.
	TM0_EXT	I/O	Timer0 external capture input/toggle output pin.
TM1	TM1	I/O	Timer1 event counter input/toggle output pin.
	TM1_EXT	I/O	Timer1 external capture input/toggle output pin.
TM2	TM2	I/O	Timer2 event counter input/toggle output pin.
	TM2_EXT	I/O	Timer2 external capture input/toggle output pin.
TM3	TM3	I/O	Timer3 event counter input/toggle output pin.
	TM3_EXT	I/O	Timer3 external capture input/toggle output pin.
UART0	UART0_RXD	I	UART0 data receiver input pin.
	UART0_TXD	O	UART0 data transmitter output pin.
	UART0_nCTS	I	UART0 clear to Send input pin.
	UART0_nRTS	O	UART0 request to Send output pin.

Group	Pin Name	Type	Description
UART1	UART1_RXD	I	UART1 data receiver input pin.
	UART1_TXD	O	UART1 data transmitter output pin.
	UART1_nCTS	I	UART1 clear to Send input pin.
	UART1_nRTS	O	UART1 request to Send output pin.
UART2	UART2_RXD	I	UART2 data receiver input pin.
	UART2_TXD	O	UART2 data transmitter output pin.
	UART2_nCTS	I	UART2 clear to Send input pin.
	UART2_nRTS	O	UART2 request to Send output pin.
USB	USB_VBUS	P	Power supply from USB host or HUB.
	USB_D-	A	USB differential signal D-.
	USB_D+	A	USB differential signal D+.
	USB_V <sub>DD</sub> 33_CAP	A	Internal power regulator output 3.3V decoupling pin.
USCI0	USCI0_CLK	I/O	USCI0 clock pin.
	USCI0_CTL0	I/O	USCI0 control 0 pin.
	USCI0_CTL1	I/O	USCI0 control 1 pin.
	USCI0_DAT0	I/O	USCI0 data 0 pin.
	USCI0_DAT1	I/O	USCI0 data 1 pin.
USCI1	USCI1_CLK	I/O	USCI1 clock pin.
	USCI1_CTL0	I/O	USCI1 control 0 pin.
	USCI1_CTL1	I/O	USCI1 control 1 pin.
	USCI1_DAT0	I/O	USCI1 data 0 pin.
	USCI1_DAT1	I/O	USCI1 data 1 pin.
USCI2	USCI2_CLK	I/O	USCI2 clock pin.
	USCI2_CTL0	I/O	USCI2 control 0 pin.
	USCI2_CTL1	I/O	USCI2 control 1 pin.
	USCI2_DAT0	I/O	USCI2 data 0 pin.
	USCI2_DAT1	I/O	USCI2 data 1 pin.
X32	X32_IN	I	External 32.768 kHz crystal input pin.
	X32_OUT	O	External 32.768 kHz crystal output pin.
XT1	XT1_IN	I	External high speed crystal input pin.
	XT1_OUT	O	External high speed crystal output pin.

5 BLOCK DIAGRAM

5.1 M251/M252 Block Diagram

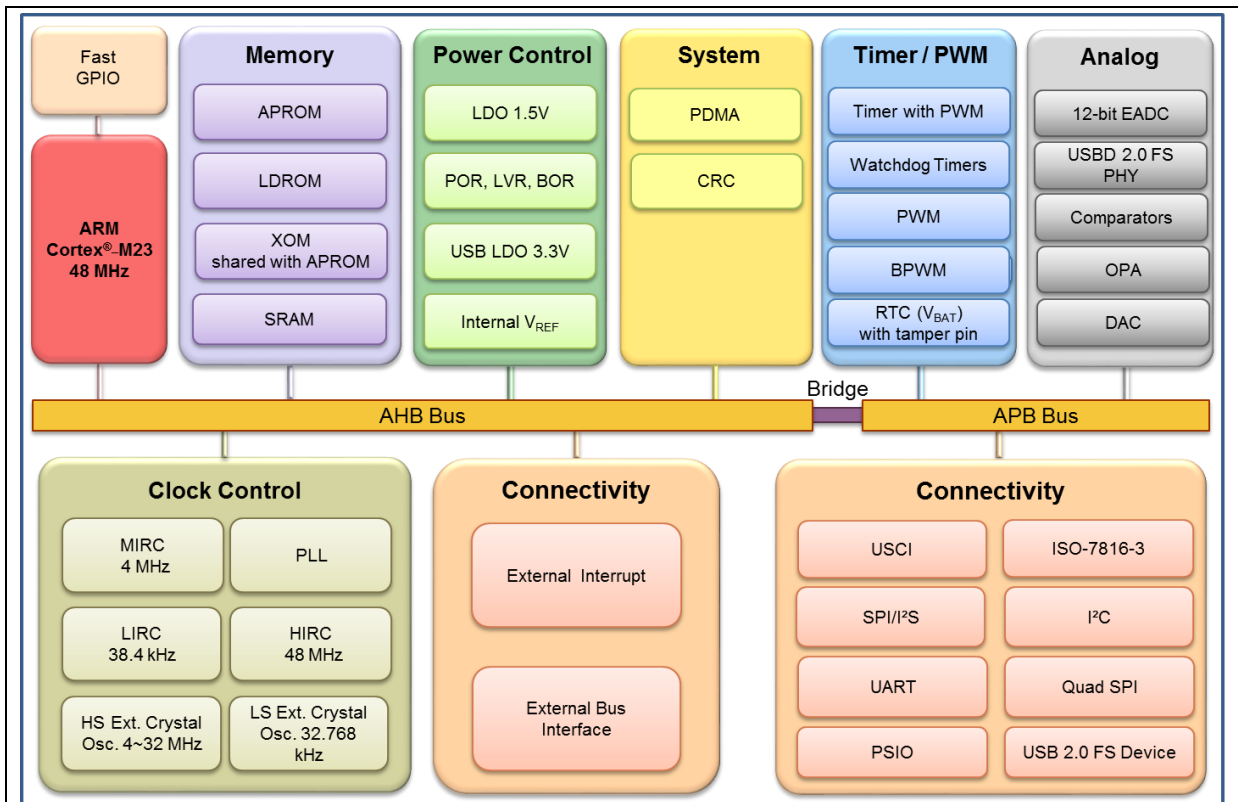

USB\* : Only supported in M252 series.

Please refer to the selection guide in section 4.2 for detailed information.

Figure 5.1-1 M251/M252 Block Diagram

## 6 FUNCTIONAL DESCRIPTION

### 6.1 Arm® Cortex®-M23 Core

The Cortex®-M23 processor is a low gate count, two-stage, and highly energy efficient 32-bit RISC processor, which has an AMBA AHB5 interface supporting Arm® TrustZone® technology, a debug access port supporting serial wire debug and single-cycle I/O ports. It has an NVIC component and MPU for memory-protection functionality. The processor also supports Security Extension. The NuMicro® M251/M252 series is embedded with Cortex®-M23 processor. Figure 6.1-1 shows the functional controller of the processor.

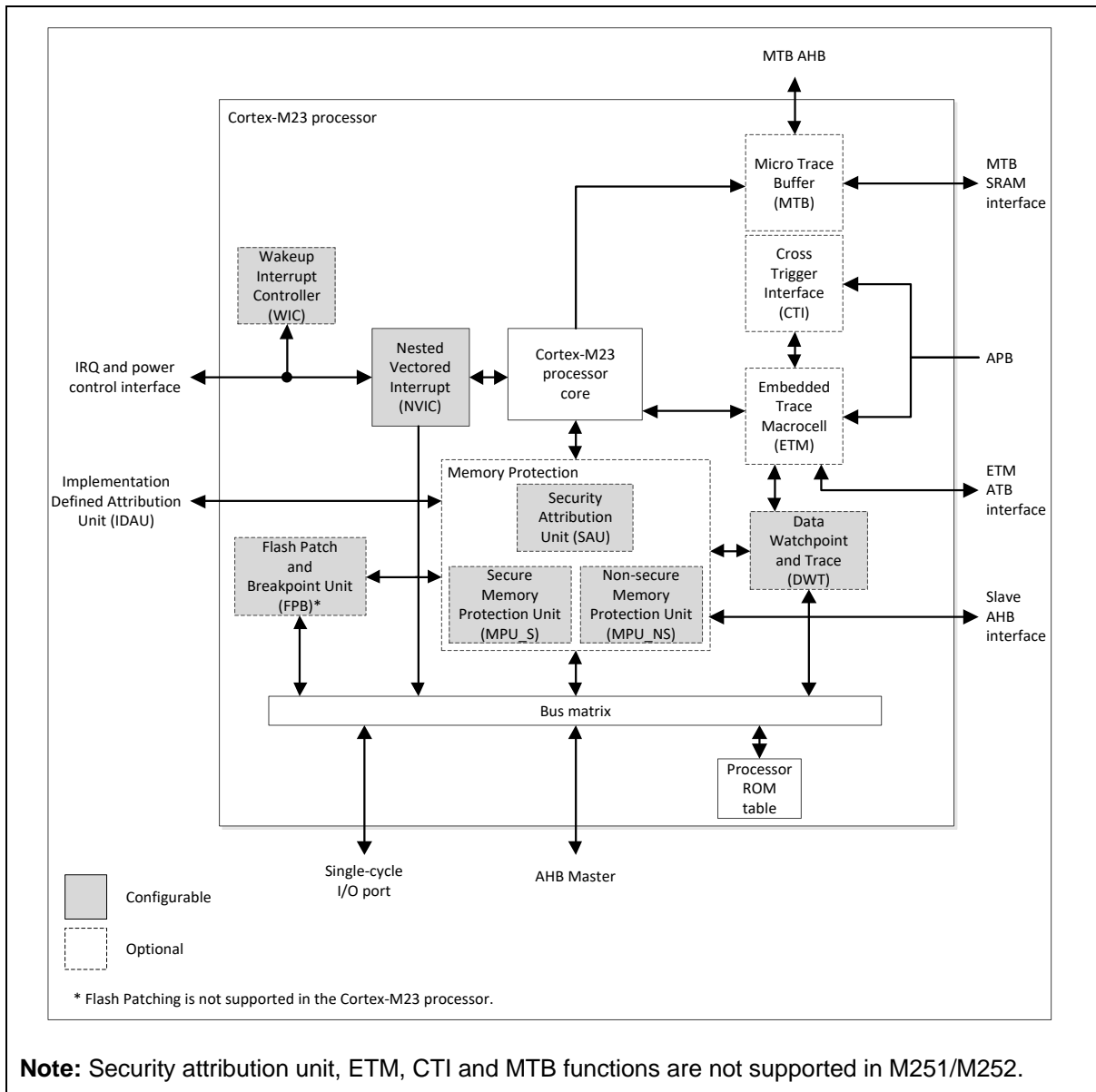

Figure 6.1-1 Cortex®-M23 Block Diagram

**Cortex®-M23 processor features:**

- Armv8-M Baseline architecture.
- Armv8-M Baseline Thumb®-2 instruction set that combines high code density with 32-bit performance.
- Support for single-cycle I/O access.
- Power control optimization of system components.
- Integrated sleep modes for low power consumption.
- Optimized code fetching for reduced Flash and ROM power consumption.
- A 32-bit Single cycle Hardware multiplier.
- A 32-bit Hardware divider.
- Deterministic, high-performance interrupt handling for time-critical applications.
- Deterministic instruction cycle timing.
- Support for system level debug authentication.
- Support for Arm® Debug Interface Architecture ADIv5.1 Serial Wire Debug (SWD).
- ETM for instruction trace.
- Separated privileged and unprivileged modes.
- Security Extension supporting a Secure and a Non-secure state.
- Protected Memory System Architecture (PMSAv8) Memory Protection Units (MPUs) for both Secure and Non-secure states.
- Security Attribution Unit (SAU).
- SysTick timers for both Secure and Non-secure states.
- A Nested Vectored Interrupt Controller (NVIC) closely integrated with the processor with up to 240 interrupts.

## 6.2 System Manager

### 6.2.1 Overview

System management includes the following sections:

- System Reset
- System Power Distribution
- SRAM Memory Organization
- System Timer (SysTick)
- Nested Vectored Interrupt Controller (NVIC)
- System Control register

### 6.2.2 System Reset

The system reset can be issued by one of the events listed below. These reset event flags can be read from SYS\_RSTSTS register to determine the reset source. Hardware reset sources are from peripheral signals. Software reset can trigger reset through setting control registers.

- Hardware Reset Sources
  - Power-on Reset
  - Low level on the nRESET pin with glitch filter time 24us
  - Watchdog Time-out Reset and Window Watchdog Reset (WDT/WWDT Reset)
  - Low Voltage Reset (LVR)
  - Brown-out Detector Reset (BOD Reset)
  - CPU Lockup Reset
- Software Reset Sources
  - CHIP Reset will reset whole chip by writing 1 to CHIPRST (SYS\_IPRST0[0])
  - MCU Reset to reboot but keeping the booting setting from APROM or LDROM by writing 1 to SYSRESETREQ (AIRCRCR[2])
  - CPU Reset for Cortex®-M23 core Only by writing 1 to CPURST (SYS\_IPRST0[1])

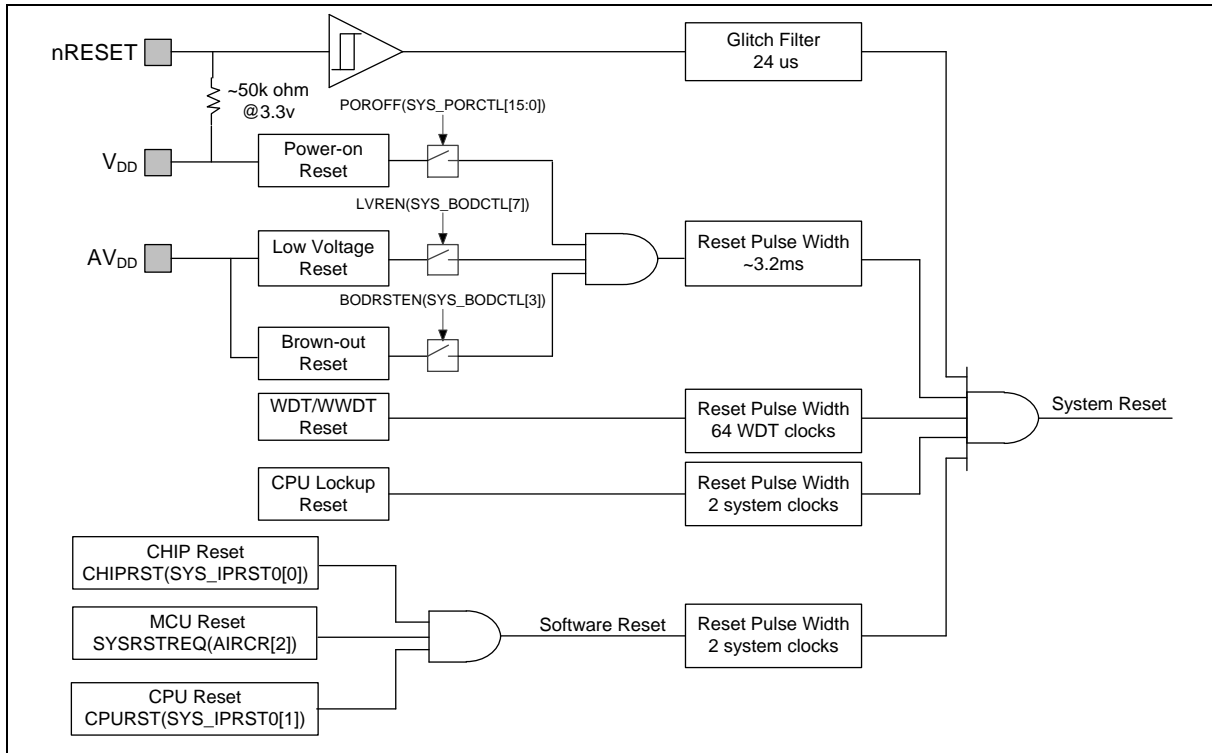

Figure 6.2-1 System Reset Sources

There are a total of 9 reset sources in the NuMicro® family. In general, CPU reset is used to reset Cortex®-M23 only; the other reset sources will reset Cortex®-M23 and all peripherals. However, there are small differences between each reset source and they are listed in Table 6.2-1.

Reset Sources Register	POR	NRESET	WDT	LVR	BOD	Lockup	CHIP	MCU	CPU
SYS_RSTSTS	0x001	Bit 1 = 1	Bit 2 = 1	Bit 3 = 1	Bit 4 = 1	Bit 8 = 1	Bit 0 = 1	Bit 5 = 1	Bit 7 = 1
CHIPRST (SYS_IPRST0[0])	0x0	-	-	-	-	-	-	-	-
BODEN (SYS_BODCTL[0])	Reload from CONFIG0	Reload from CONFIG0	Reload from CONFIG0	Reload from CONFIG0	-	Reload from CONFIG0	Reload from CONFIG0	Reload from CONFIG0	-
BODVL (SYS_BODCTL[2:1])									
BODRSTEN (SYS_BODCTL[3])									
HXTEN (CLK_PWRCTL[0])	Reload from CONFIG0	Reload from CONFIG0	Reload from CONFIG0	Reload from CONFIG0	Reload from CONFIG0	Reload from CONFIG0	Reload from CONFIG0	Reload from CONFIG0	
LXTEN (CLK_PWRCTL[1])	0x0	-	-	-	-	-	-	-	-
WDTCKEN (CLK_APBCLK0[0])	0x1	-	0x1	-	-	-	0x1	-	-

HCLKSEL (CLK_CLKSEL0[2:0])	Reload from CONFIG0	Reload from CONFIG0	Reload from CONFIG0	Reload from CONFIG0	Reload from CONFIG0	Reload from CONFIG0	Reload from CONFIG0	Reload from CONFIG0	Reload from CONFIG0	-
WDTSEL (CLK_CLKSEL1[1:0])	0x3	0x3	-	-	-	-	-	-	-	-
HXTSTB (CLK_STATUS[0])	0x0	-	-	-	-	-	-	-	-	-
LXTSTB (CLK_STATUS[1])	0x0	-	-	-	-	-	-	-	-	-
PLLSTB (CLK_STATUS[2])	0x0	-	-	-	-	-	-	-	-	-
HIRCSTB (CLK_STATUS[4])	0x0	-	-	-	-	-	-	-	-	-
CLKSFAIL (CLK_STATUS[7])	0x0	0x0	-	-	-	-	-	-	-	-
RSTEN (WDT_CTL[1])	Reload from CONFIG0	Reload from CONFIG0	Reload from CONFIG0	Reload from CONFIG0	Reload from CONFIG0	-	Reload from CONFIG0	-	-	-
WDTEN (WDT_CTL[7])										
WDT_CTL except bit 1 and bit 7.	0x0800	0x0800	0x0800	0x0800	0x0800	-	0x0800	-	-	-
WDT_ALTCTL	0x0000	0x0000	0x0000	0x0000	0x0000	-	0x0000	-	-	-
WWDT_RLDCNT	0x0000	0x0000	0x0000	0x0000	0x0000	-	0x0000	-	-	-
WWDT_CTL	0x3F0800	0x3F0800	0x3F0800	0x3F0800	0x3F0800	-	0x3F0800	-	-	-
WWDT_STATUS	0x0000	0x0000	0x0000	0x0000	0x0000	-	0x0000	-	-	-
WWDT_CNT	0x3F	0x3F	0x3F	0x3F	0x3F	-	0x3F	-	-	-
BS (FMC_ISPCTL[1])	Reload from CONFIG0	Reload from CONFIG0	Reload from CONFIG0	Reload from CONFIG0	Reload from CONFIG0	-	Reload from CONFIG0	-	-	-
BL (FMC_ISPCTL[16])										
FMC_DFBA	Reload from CONFIG1	Reload from CONFIG1	Reload from CONFIG1	Reload from CONFIG1	Reload from CONFIG1	-	Reload from CONFIG1	-	-	-
CBS (FMC_ISPSTS[2:1])	Reload from CONFIG0	Reload from CONFIG0	Reload from CONFIG0	Reload from CONFIG0	Reload from CONFIG0	-	Reload from CONFIG0	-	-	-
VECMAP (FMC_ISPSTS[23:9])	Reload base on CONFIG0	Reload base on CONFIG0	Reload base on CONFIG0	Reload base on CONFIG0	Reload base on CONFIG0	-	Reload base on CONFIG0	-	-	-
Other Peripheral Registers	Reset Value									-
FMC Registers	Reset Value									
<b>Note:</b> '-' means that the value of register keeps original setting.										

Table 6.2-1 Reset Value of Registers

6.2.2.1 nRESET Reset

The nRESET reset means to generate a reset signal by pulling low nRESET pin, which is an asynchronous reset input pin and can be used to reset system at any time. When the nRESET voltage is lower than  $0.2 V_{DD}$  and the state keeps longer than 24 us (glitch filter), chip will be reset. The nRESET reset will control the chip in reset state until the nRESET voltage rises above  $0.7 V_{DD}$  and the state keeps longer than 24 us (glitch filter). The PINRF(SYS\_RSTSTS[1]) will be set to 1 if the previous reset source is nRESET reset. Table 6.2-2 shows the nRESET reset waveform.

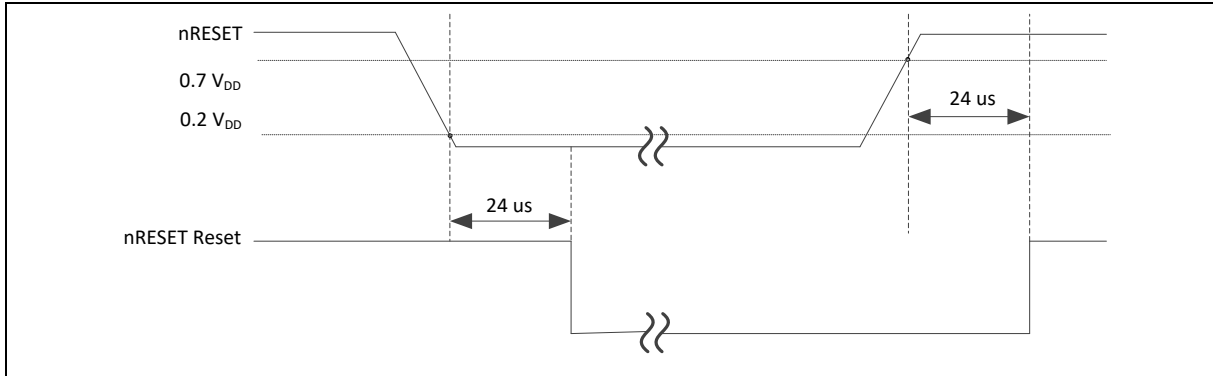

Figure 6.2-2 nRESET Reset Waveform

6.2.2.2 Power-on Reset (POR)

The Power-on reset (POR) is used to generate a stable system reset signal and forces the system to be reset when power-on to avoid unexpected behavior of MCU. When applying the power to MCU, the POR module will detect the rising voltage and generate reset signal to system until the voltage is ready for MCU operation. At POR reset, the PORF(SYS\_RSTSTS[0]) will be set to 1 to indicate there is a POR reset event. The PORF(SYS\_RSTSTS[0]) bit can be cleared by writing 1 to it. Figure 6.2-3 shows the power-on reset waveform.

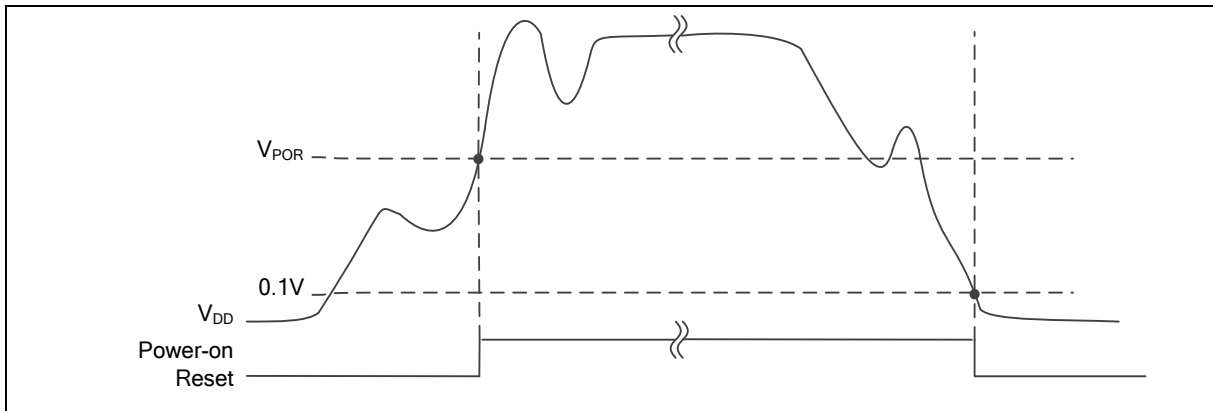

Figure 6.2-3 Power-on Reset (POR) Waveform

6.2.2.3 Low Voltage Reset (LVR)

If the Low Voltage Reset function is enabled by setting the Low Voltage Reset Enable Bit LVREN (SYS\_BODCTL[7]) to 1, after 200us delay, LVR detection circuit will be stable and the LVR function will be active. Then LVR function will detect  $AV_{DD}$  during system operation. When the  $AV_{DD}$  voltage is lower than  $V_{LVR}$  and the state keeps longer than De-glitch time set by LVRDGSEL (SYS\_BODCTL[14:12]), chip will be reset. The LVR reset will control the chip in reset state until the  $AV_{DD}$  voltage rises above  $V_{LVR}$  and the state keeps longer than De-glitch time set by LVRDGSEL

(SYS\_BODCTL[14:12]). The default setting of Low Voltage Reset is enabled without De-glitch function. Figure 6.2-4 shows the Low Voltage Reset waveform.

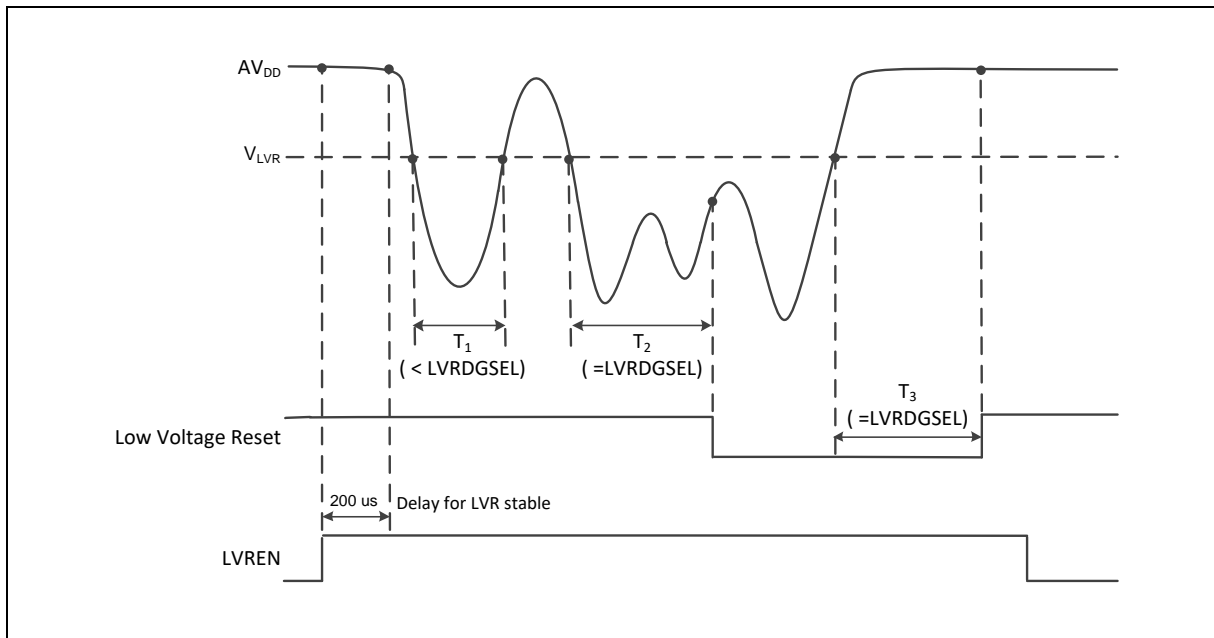

Figure 6.2-4 Low Voltage Reset (LVR) Waveform

#### 6.2.2.4 Brown-out Detector Reset (BOD Reset)

If the Brown-out Detector (BOD) function is enabled by setting the Brown-out Detector Enable Bit BODEN (SYS\_BODCTL[0]), Brown-out Detector function will detect AV<sub>DD</sub> during system operation. When the AV<sub>DD</sub> voltage is lower than V<sub>BOD</sub> which is decided by BODEN and BODVL (SYS\_BODCTL[18:16]) and the state keeps longer than De-glitch time set by BODDGSEL (SYS\_BODCTL[10:8]), chip will be reset. The BOD reset will control the chip in reset state until the AV<sub>DD</sub> voltage rises above V<sub>BOD</sub> and the state keeps longer than De-glitch time set by BODDGSEL. The default value of BODEN, BODVL and BODRSTEN (SYS\_BODCTL[3]) is set by Flash controller user configuration register CBODEN (CONFIG0 [19]), CBOV (CONFIG0 [23:21]) and CBORST(CONFIG0[20]) respectively. User can determine the initial BOD setting by setting the CONFIG0 register. Figure 6.2-5 shows the Brown-out Detector waveform.

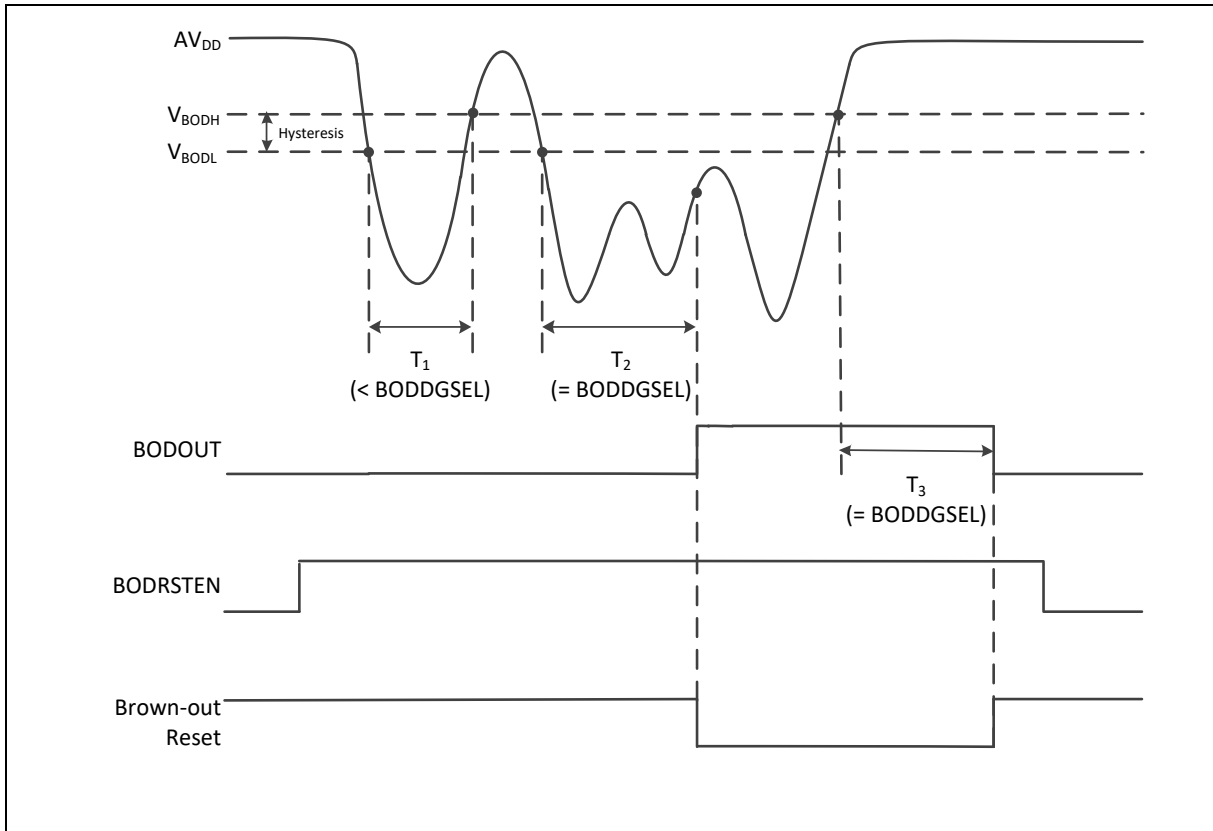

Figure 6.2-5 Brown-out Detector (BOD) Waveform

6.2.2.5 Watchdog Timer Reset (WDT)

In most industrial applications, system reliability is very important. To automatically recover the MCU from failure status is one way to improve system reliability. The watchdog timer(WDT) is widely used to check if the system works fine. If the MCU is crashed or out of control, it may cause the watchdog time-out. User may decide to enable system reset during watchdog time-out to recover the system and take action for the system crash/out-of-control after reset.

Software can check if the reset is caused by watchdog time-out to indicate the previous reset is a watchdog reset and handle the failure of MCU after watchdog time-out reset by checking WDTRF(SYS\_RSTSTS[2]).

6.2.2.6 CPU Lockup Reset

CPU enters lockup status after CPU produces hardfault at hardfault handler and chip gives immediate indication of seriously errant kernel software. This is the result of the CPU being locked because of an unrecoverable exception following the activation of the processor’s built in system state protection hardware. When chip enters debug mode, the CPU lockup reset will be ignored.

6.2.2.7 CPU Reset, CHIP Reset and MCU Reset

The CPU Reset means only Cortex®-M23 core is reset and all other peripherals remain the same status after CPU reset. User can set the CPURST(SYS\_IPRST0[1]) to 1 to assert the CPU Reset signal.

The CHIP Reset is same with Power-on Reset. The CPU and all peripherals are reset and BS(FMC\_ISPCTL[1]) bit is automatically reloaded from CONFIG0 setting. User can set the CHIPRST(SYS\_IPRST0[1]) to 1 to assert the CHIP Reset signal.

The MCU Reset is similar with CHIP Reset. The difference is that BS(FMC\_ISPCTL[1]) will not be reloaded from CONFIG0 setting and keep its original software setting for booting from APROM or

LDR0M. User can set the SYSRESETREQ(AIRCR[2]) to 1 to assert the MCU Reset.

### 6.2.3 System Power Distribution

In this chip, power distribution is divided into four segments:

- Analog power from AV<sub>DD</sub> and AV<sub>SS</sub> provides the power for analog components operation.
- Digital power from V<sub>DD</sub> and V<sub>SS</sub> supplies the power to the internal regulator which provides a fixed 1.5V power for digital operation and I/O pins.
- USB transceiver power from VBUS offers the power for operating the USB transceiver.
- RTC power from regulator uninterrupted power domain provides, the power for RTC and 20 bytes backup registers.

Analog power (AV<sub>DD</sub>) should be the same voltage level of the digital power (V<sub>DD</sub>). Figure 6.2-6 shows the power distribution of the M251/M252 series.

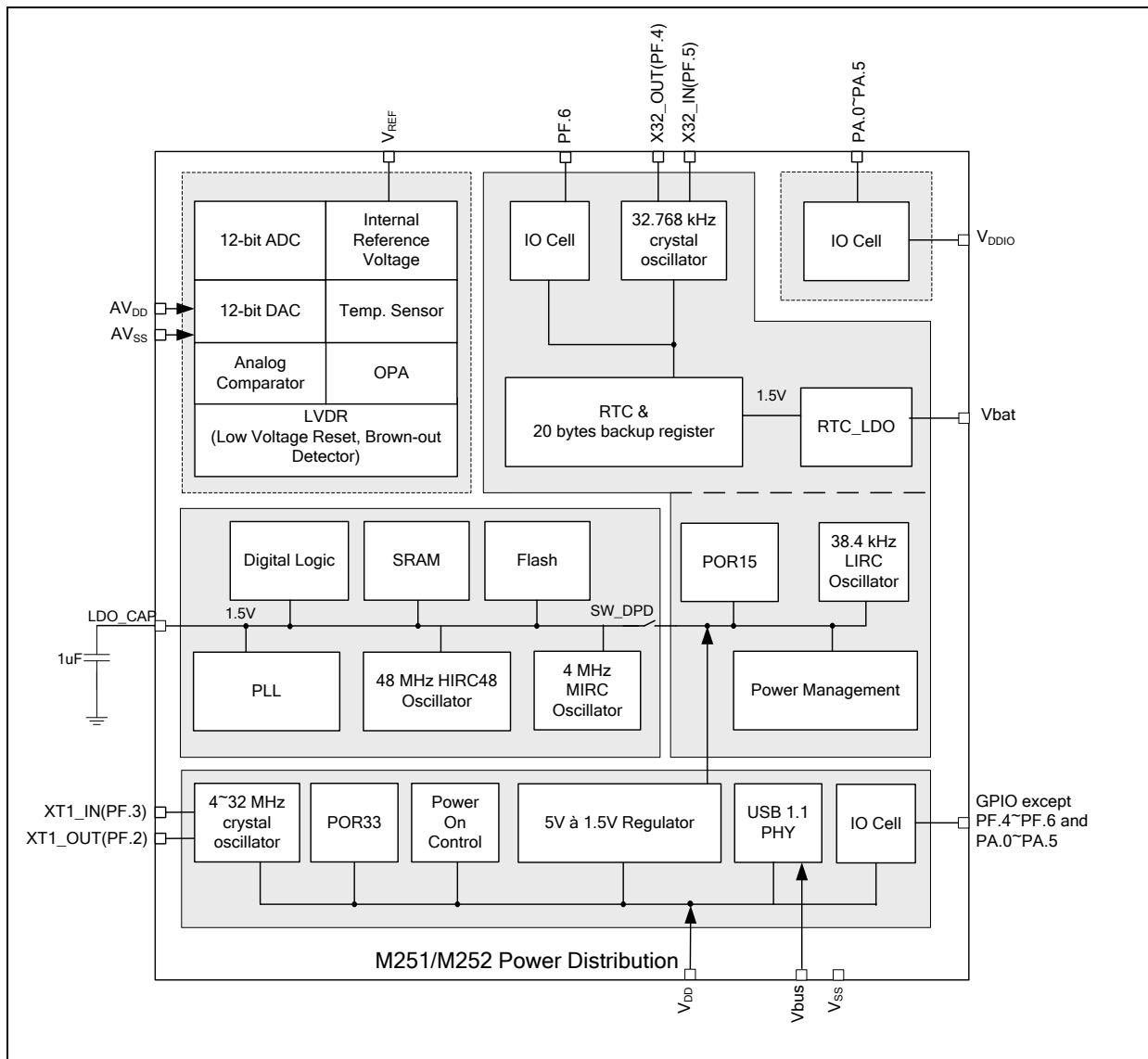

Figure 6.2-6 NuMicro® M251/M252 Power Distribution Diagram

### 6.2.4 Power Modes and Wake-up Sources

The M251/M252 series has a power manager unit to support several operating modes for saving power. Table 6.2-2 lists all power modes in the M251/M252 series.

Mode	CPU Operating Maximum Speed ( MHz)	LDO_CAP(V)	Clock Disable
Normal mode	48	1.5	All clocks are disabled by control register.
Idle mode	CPU enters Sleep mode	1.5	Only CPU clock is disabled.
Power-down mode	CPU enters Deep Sleep mode	1.5	Most clocks are disabled except LIRC/LXT, and only RTC/WDT/Timer/UART peripheral clocks still enable if their clock sources are selected as LIRC/LXT.
Fast wake up Power-down mode (FWPD)	CPU enters Sleep mode	1.5	Most clocks are disabled except LIRC/LXT, and only RTC/WDT/Timer/UART peripheral clocks still enable if their clock sources are selected as LIRC/LXT.
Deep Power-down mode (DPD)	Power off	1.5	Only LIRC/LXT still enable for RTC function and wake-up timer usage

Table 6.2-2 Power Mode Table

There are different power mode entry settings. Each power mode has different entry setting and leaving condition. Table 6.2-3 shows the entry setting for each power mode. When chip power-on, chip is running at normal mode. User can enter each mode by setting SLEEPDEEP (SCR[2]), PDEN (CLK\_PWRCTL:[7]) and PDMSEL (CLK\_PMUCTL[2:0]) and execute WFI instruction.

Register/Instruction Mode	SLEEPDEEP (SCR[2])	PDEN (CLK_PWRCTL[7])	PDMSEL (CLK_PMUCTL[2:0])	CPU Run WFI Instruction
Normal mode	0	0	0	NO
Idle mode (CPU enters Sleep mode)	0	0	0	YES
Power-down mode (CPU enters Deep Sleep mode)	1	1	0	YES
Fast wake up Power-down mode (FWPD)	1	1	2	YES
Deep Power-down mode (CPU enters Sleep mode)	1	1	6	YES

Table 6.2-3 Power Mode Difference Table

There are several wake-up sources in Idle mode and Power-down mode. Table 6.2-4 lists the available clocks for each power mode.

Power Mode	Normal Mode	Idle Mode	Power-Down Mode
Definition	CPU is in active state	CPU is in sleep state	CPU is in sleep state and all clocks stop except LXT and LIRC. SRAM content retained.
Entry Condition	Chip is in normal mode after system reset released	CPU executes WFI instruction.	CPU sets sleep mode enable and power down enable and executes WFI instruction.

Wake-up Sources	N/A	All interrupts	RTC, WDT, I <sup>2</sup> C, Timer, UART, BOD, GPIO, EINT, USCI, USB and ACMP
Available Clocks	All	All except CPU clock	LXT and LIRC
After Wake-up	N/A	CPU back to normal mode	CPU back to normal mode

Table 6.2-4 Power Mode Difference Table

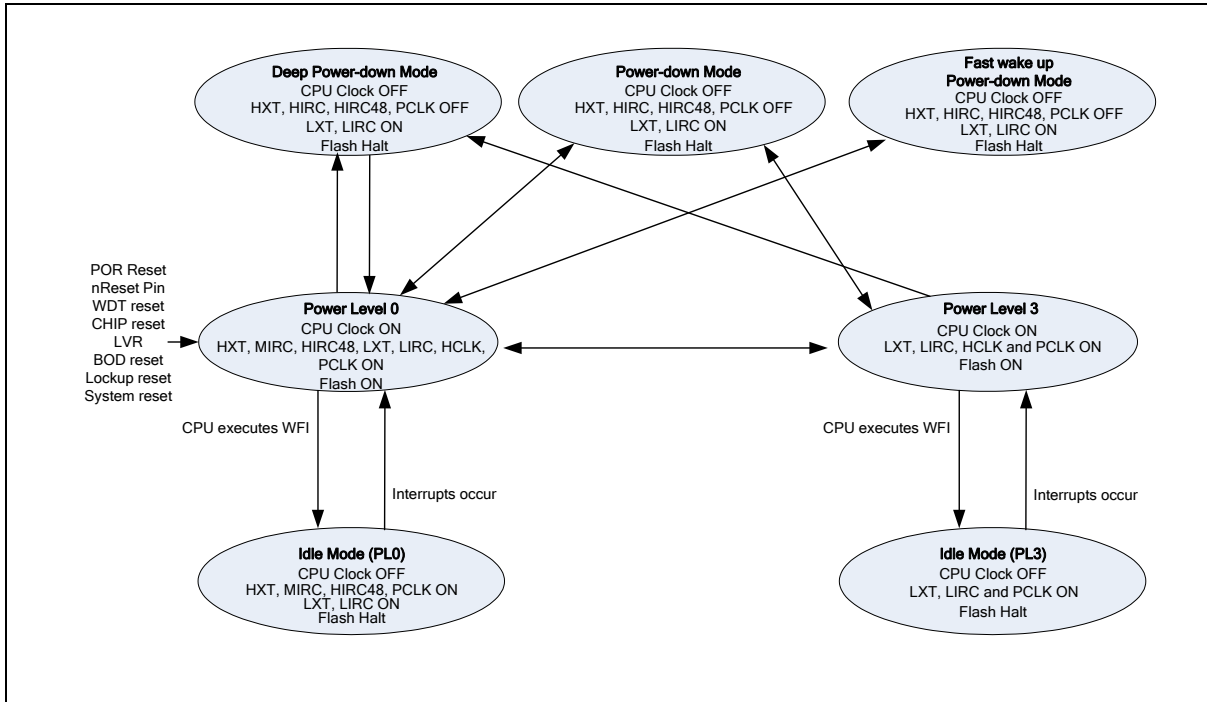

Figure 6.2-7 Power Mode State Machine

1. LXT (32768 Hz XTL) ON or OFF depends on SW setting in normal mode.
2. LIRC (38.4 kHz OSC) ON or OFF depends on S/W setting in normal mode.
3. If TIMER clock source is selected as LIRC/LXT and LIRC/LXT is on.
4. If WDT clock source is selected as LIRC and LIRC is on.
5. If RTC clock source is selected as LXT and LXT is on.
6. If UART clock source is selected as LXT and LXT is on.

	Normal Mode	Idle Mode	Power-Down Mode PD	DPD
HXT (4~32 MHz XTL)	ON	ON	Halt	Halt
MIRC (4 MHz OSC)	ON	ON	Halt	Halt
HIRC48 (48 MHz OSC)	ON	ON	Halt	Halt
LXT (32768 Hz XTL)	ON	ON	ON/OFF <sup>1</sup>	ON/OFF <sup>1</sup>
LIRC (38.4 kHz OSC)	ON	ON	ON/OFF <sup>2</sup>	ON/OFF <sup>2</sup>
PLL	ON/OFF	ON/OFF	Halt	Halt
LDO	ON	ON	ON	OFF

CPU	ON	Halt	Halt	Halt
HCLK/PCLK	ON	ON	Halt	Halt
SRAM retention	ON	ON	ON	OFF
FLASH	ON	ON	Halt	Halt
GPIO	ON	ON	Halt	Halt
PDMA	ON	ON	Halt	Halt
TIMER	ON	ON	ON/OFF <sup>3</sup>	Halt
PWM	ON	ON	Halt	Halt
WDT	ON	ON	ON/OFF <sup>4</sup>	Halt
WWDT	ON	ON	Halt	Halt
RTC	ON	ON	ON/OFF <sup>5</sup>	ON/OFF <sup>5</sup>
UART	ON	ON	ON/OFF <sup>6</sup>	Halt
SC	ON	ON	Halt	Halt
USCI	ON	ON	Halt	Halt
I <sup>2</sup> C	ON	ON	Halt	Halt
SPI	ON	ON	Halt	Halt
USB	ON	ON	Halt	Halt
ADC	ON	ON	Halt	Halt
ACMP	ON	ON	Halt	Halt

Table 6.2-5 Clocks in Power Modes

**Wake-up sources in Power-down mode:**

RTC, WDT, I<sup>2</sup>C, Timer, UART, USCI, BOD, GPIO, USB, and ACMP.

After chip enters power down, the following wake-up sources can wake chip up to normal mode. Table 6.2-5 lists the condition about how to enter Power-down mode again for each peripheral.

\*User needs to wait this condition before setting PDEN(CLK\_PWRCTL[7]) and execute WFI to enter Power-down mode.

Wake-Up Source	Wake-Up Condition	Power-Down Mode		System Can Enter Power-Down Mode Again Condition*
		PD FWKPD	DPD	
BOD	Brown-Out Detector Interrupt	Y	N	After software writes 1 to clear BODIF (SYS_BODCTL[4]).
LVR	LVR Reset	Y	N	After software writes 1 to clear LVRF (SYS_RSTSTS[3])
		N	Y	After software writes 1 to clear LVRWK (CLK_PMUSTS[12]) when DPD mode is entered.
INT	External Interrupt	Y	N	After software write 1 to clear the Px_INTSRC[n] bit.
GPIO	GPIO Interrupt	Y	N	After software write 1 to clear the Px_INTSRC[n] bit.

GPIO(PC.0) Wake-up pin	Rising or falling edge event, 1-pin	N	Y	PINWK(CLK_PMUSTS[0]) is cleared when DPD mode is entered.
GPIO(PB.0) Wake-up pin	Rising or falling edge event, 1-pin	N	Y	PINWK(CLK_PMUSTS[3]) is cleared when DPD mode is entered.
GPIO(PB.2) Wake-up pin	Rising or falling edge event, 1-pin	N	Y	PINWK(CLK_PMUSTS[4]) is cleared when DPD mode is entered.
GPIO(PB.12) Wake-up pin	Rising or falling edge event, 1-pin	N	Y	PINWK(CLK_PMUSTS[5]) is cleared when DPD mode is entered.
GPIO(PF.6) Wake-up pin	Rising or falling edge event, 1-pin	N	Y	PINWK(CLK_PMUSTS[6]) is cleared when DPD mode is entered.
TIMER	Timer Interrupt	Y	N	After software writes 1 to clear TWKF (TIMERx_INTSTS[1]) and TIF (TIMERx_INTSTS[0]).
Wakeup timer	Wakeup by wake-up timer time-out	N	Y	DPD_TMRWK (CLK_PMUSTS[2]) or DPD_TMRWK (CLK_PMUSTS[6]) is cleared when SPD or DPD mode is entered.
WDT	WDT Interrupt	Y	N	After software writes 1 to clear WKF (WDT_CTL[5]) (Write Protect).
RTC	Alarm Interrupt	Y	N	After software writes 1 to clear ALMIF (RTC_INTSTS[0]).
	Time Tick Interrupt	Y	N	After software writes 1 to clear TICKIF (RTC_INTSTS[1]).
RTC	Wakeup by RTC alarm	N	Y	RTCWK (CLK_PMUSTS[2]) is cleared when DPD mode is entered.
	Wakeup by RTC tick time	N	Y	RTCWK (CLK_PMUSTS[2]) is cleared when DPD mode is entered.
	Wakeup by tamper event	N	Y	RTCWK (CLK_PMUSTS[2]) is cleared when DPD mode is entered.
UART	nCTS wake-up	Y	N	After software writes 1 to clear CTSWKF (UARTx_WKSTS[0]).
	Incoming Data wake-up	Y	N	After software writes 1 to clear DATWKF (UARTx_WKSTS[1]).
	Received FIFO Threshold Wake-up	Y	N	After software writes 1 to clear RFRTWKF (UARTx_WKSTS[2]).
	RS-485 AAD Mode Wake-up	Y	N	After software writes 1 to clear RS485WKF (UARTx_WKSTS[3]).
	Received FIFO Threshold Time-out Wake-up	Y	N	After software writes 1 to clear TOUTWKF (UARTx_WKSTS[4]).
USCI UART	CTS Toggle	Y	N	After software writes 1 to clear WKF (UUART_WKSTS[0]).
	Data Toggle	Y	N	After software writes 1 to clear WKF (UUART_WKSTS[0]).
USCI I <sup>2</sup> C	Data toggle	Y	N	After software writes 1 to clear WKF (UI2C_WKSTS[0]).
	Address match	Y	N	After software writes 1 to clear WKAKDONE (UI2C_PROTSTS[16], and then writes 1 to clear WKF (UI2C_WKSTS[0]).
USCI SPI	SS Toggle	Y	N	After software writes 1 to clear WKF (USPI_WKSTS[0]).
I <sup>2</sup> C	Address match wake-up	Y	N	After software writes 1 to clear WKAKDONE (I2C_WKSTS[1]). Then software writes 1 to clear WKIF (I2C_WKSTS[0]).
USBD	Remote Wake-up	Y	N	After software writes 1 to clear BUSIF (USBD_INTSTS[0]).
ACMP	Comparator Power-	Y	N	After software writes 1 to clear WKIF0 (ACMP_STATUS[8]).

	Down Wake-Up Interrupt			and WKIF1 (ACMP_STATUS[9]).
--	------------------------	--	--	-----------------------------

Table 6.2-6 Condition of Entering Power-down Mode Again

### 6.2.5 Chip Bus Matrix

The M251/M252 series provides 4G-byte addressing space. The memory locations assigned to each on-chip controllers are shown in Table 6.2-7. The detailed register definition, memory space, and programming will be described in the following sections for each on-chip peripheral. The M251/M252 series only supports little-endian data format.

### 6.2.6 System Memory Map

The M251/M252 series provides 4G-byte addressing space. The memory locations assigned to each on-chip controllers are shown in Table 6.2-7. The detailed register definition, memory space, and programming will be described in the following sections for each on-chip peripheral. The M251/M252 series only supports little-endian data format.

Address Space	Token	Controllers
Flash and SRAM Memory Space		
0x0000_0000 – 0x0003_FFFF	FLASH_BA	FLASH Memory Space (256 Kbytes)
0x2000_0000 – 0x2000_7FFF	SRAM0_BA	SRAM Memory Space (32 Kbytes)
0x6000_0000 – 0x6FFF_FFFF	EXTMEM_BA	External Memory Space (256 Mbytes)
Peripheral Controllers Space (0x4000_0000 – 0x400F_FFFF)		
0x4000_0000 – 0x4000_01FF	SYS_BA	System Control Registers
0x4000_0200 – 0x4000_02FF	CLK_BA	Clock Control Registers
0x4000_0300 – 0x4000_03FF	NMI_BA	NMI Control Registers
0x4000_4000 – 0x4000_4FFF	GPIO_BA	GPIO Control Registers
0x4000_8000 – 0x4000_8FFF	PDMA_BA	Peripheral DMA Control Registers
0x4000_C000 – 0x4000_CFFF	FMC_BA	Flash Memory Control Registers
0x4001_0000 – 0x4001_0FFF	EBI_BA	External Bus Interface Control Registers
0x4003_1000 – 0x4003_1FFF	CRC_BA	CRC Generator Registers
APB Controllers Space (0x4000_0000 ~ 0x400F_FFFF)		
0x4004_0000 – 0x4004_0FFF	WDT_BA	Watchdog Timer Control Registers
0x4004_1000 – 0x4004_1FFF	RTC_BA	Real Time Clock (RTC) Control Register
0x4004_3000 – 0x4004_3FFF	EADC_BA	Enhanced Analog-Digital-Converter (EADC) Control Registers
0x4004_5000 – 0x4004_5FFF	ACMP01_BA	Analog Comparator 0/ 1 Control Registers
0x4004_6000 – 0x4004_6FFF	OPA_BA	OP Amplifier Control Registers
0x4004_7000 – 0x4004_7FFF	DAC_BA	DAC Control Registers
0x4005_0000 – 0x4005_0FFF	TMR01_BA	Timer0/Timer1 Control Registers
0x4005_1000 – 0x4005_1FFF	TMR23_BA	Timer2/Timer3 Control Registers
0x4005_8000 – 0x4005_8FFF	PWM0_BA	PWM0 Control Registers
0x4005_9000 – 0x4005_9FFF	PWM1_BA	PWM1 Control Registers

0x4005_A000 – 0x4005_AFFF	BPWM0_BA	BPWM0 Control Registers
0x4005_B000 – 0x4005_BFFF	BPWM1_BA	BPWM1 Control Registers
0x4006_0000 – 0x4006_0FFF	QSPI0_BA	QSPI0 Control Registers
0x4006_1000 – 0x4006_1FFF	SPI0_BA	SPI0 Control Registers
0x4007_0000 – 0x4007_0FFF	UART0_BA	UART0 Control Registers
0x4007_1000 – 0x4007_1FFF	UART1_BA	UART1 Control Registers
0x4007_2000 – 0x4007_2FFF	UART2_BA	UART2 Control Registers
0x4008_0000 – 0x4008_0FFF	I2C0_BA	I2C0 Control Registers
0x4008_1000 – 0x4008_1FFF	I2C1_BA	I2C1 Control Registers
0x4009_0000 – 0x4009_0FFF	SC0_BA	Smartcard Host 0 Control Registers
0x400C_0000 – 0x400C_0FFF	USBD_BA	USB Device Control Register
0x400C_3000 – 0x400C_3FFF	PSIO_BA	PSIO Control Register
0x400D_0000 – 0x400D_0FFF	USCI0_BA	USCI0 Control Registers
0x400D_1000 – 0x400D_1FFF	USCI1_BA	USCI1 Control Registers
0x400D_2000 – 0x400D_2FFF	USCI2_BA	USCI2 Control Registers
System Controllers Space (0xE000_E000 ~ 0xE000_EFFF)		
0xE000_E010 – 0xE000_E0FF	SCS_BA	System Timer Control Registers
0xE000_E100 – 0xE000_ECFF	SCS_BA	External Interrupt Controller Control Registers
0xE000_ED00 – 0xE000_ED8F	SCS_BA	System Control Registers

Table 6.2-7 Address Space Assignments for On-Chip Controllers

### 6.2.7 SRAM Memory Organization

The M251/M252 series supports embedded SRAM with up to 32 Kbytes size.

- Supports up to 32 Kbytes SRAM
- Supports byte /half word /word write
- Supports oversize response error

Table 6.2-9 shows the M251/M252 series SRAM organization. The address between 0x2000\_8000 to 0x3FFF\_FFFF is illegal memory space and chip will enter hardfault if CPU accesses these illegal memory addresses.

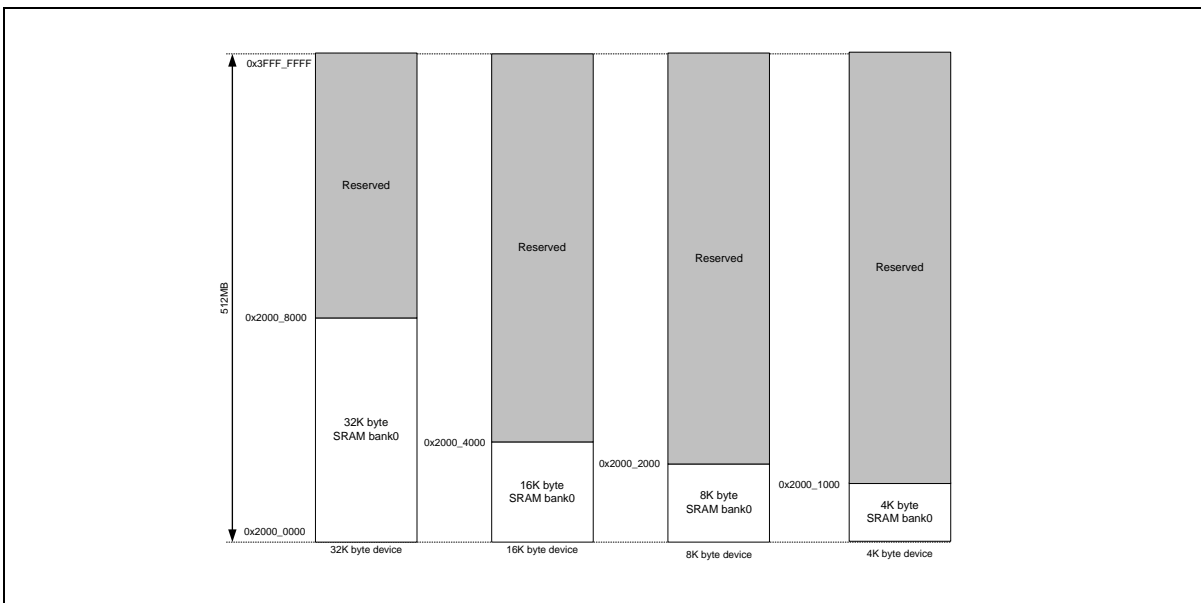

Figure 6.2-8 SRAM Memory Organization

### 6.2.8 IRC Auto Trim

This chip supports auto-trim function: the HIRC trim (48 MHz RC oscillator) and MIRC trim (4.032 RC oscillator), according to the accurate LXT (32.768 kHz crystal oscillator) or internal USB synchronous mode, automatically gets accurate output frequency, 0.25 % deviation within all temperature ranges.

For instance, the system needs an accurate 4.032 MHz clock. In such case, if neither using use PLL as the system clock source nor soldering 32.768 kHz crystal in system, user has to set REFCKSEL (SYS\_MIRCTRIMCTL[10] reference clock selection) to “1”, set FREQSEL (SYS\_MIRCTRIMCTL[1:0] trim frequency selection) to “10”, and the auto-trim function will be enabled. Interrupt status bit FREQLOCK (SYS\_MIRCTRIMSTS[0] MIRC frequency lock status) “1” indicates the MIRC output frequency is accurate within 0.25% deviation.

In HIRC case, the system needs an accurate 48 MHz clock. In such case, if neither using use PLL as the system clock source nor soldering 32.768 kHz crystal in system, user has to set REFCKSEL (SYS\_HIRCTRIMCTL[10] reference clock selection) to “1”, set FREQSEL (SYS\_HIRCTRIMCTL[1:0] trim frequency selection) to “10”, and the auto-trim function will be enabled. Interrupt status bit FREQLOCK (SYS\_HIRCTRIMSTS[8] HIRC frequency lock status) “1” indicates the HIRC output frequency is accurate within 0.25% deviation.

HIRC trim and MIRC trim only can work properly when the clock sources are stable. When the RC clock or the reference clock are not stable or the system go into power down, HIRC trim and MIRC trim need to wait until the clock are stable or system wake up, then it can be enable or it will get a clock error flag.

### 6.2.9 UART0\_TXD/USCIO\_DAT0 Modulation with PWM

This chip supports UART0\_TXD/USCIO\_DAT0 to modulate with PWM channel. User can set MODPWMSEL(SYS\_MODCTL[7:4]) to select which PWM0 channel to modulate with UART0\_TXD/USCIO\_DAT0 and set MODEN(SYS\_MODCTL[0]) to enable modulation function.

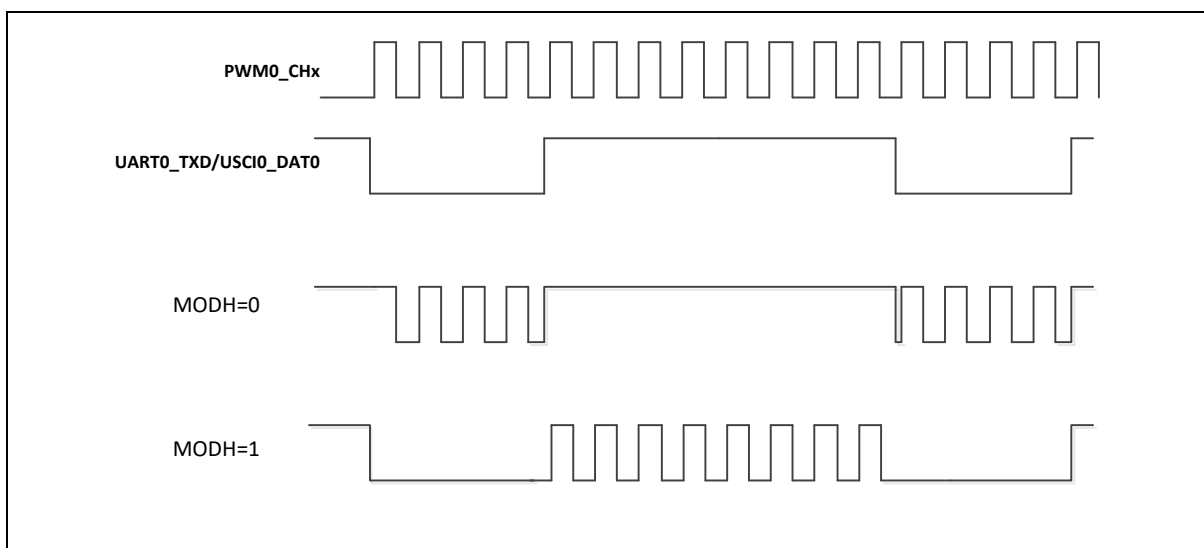

Figure 6.2-11 UART0\_TXD/USCIO\_DAT0 Modulated with PWM Channel

### 6.2.10 System Timer (SysTick)

The Cortex®-M23 includes an integrated system timer, SysTick, which provides a simple, 24-bit clear-on-write, decrementing, wrap-on-zero counter with a flexible control mechanism. The counter can be used as a Real Time Operating System (RTOS) tick timer or as a simple counter.

When system timer is enabled, it will count down from the value in the SysTick Current Value Register (SYST\_VAL) to zero, and reload (wrap) to the value in the SysTick Reload Value Register (SYST\_LOAD) on the next clock cycle, and then decrement on subsequent clocks. When the counter transitions to zero, the COUNTFLAG status bit is set. The COUNTFLAG bit clears on reads.

The SYST\_VAL value is UNKNOWN on reset. Software should write to the register to clear it to zero before enabling the feature. This ensures the timer will count from the SYST\_LOAD value rather than an arbitrary value when it is enabled.

If the SYST\_LOAD is zero, the timer will be maintained with a current value of zero after it is reloaded with this value. This mechanism can be used to disable the feature independently from the timer enable bit.

For more detailed information, please refer to the “Arm® Cortex®-M23 Technical Reference Manual” and “Arm v8-M Architecture Reference Manual”.

**6.2.11 Nested Vectored Interrupt Controller (NVIC)**

The NVIC and the processor core interface are closely coupled to enable low latency interrupt processing and efficient processing of late arriving interrupts. The NVIC maintains knowledge of the stacked, or nested, interrupts to enable tail-chaining of interrupts. You can only fully access the NVIC from privileged mode, but you can cause interrupts to enter a pending state in user mode if you enable the Configuration and Control Register. Any other user mode access causes a bus fault. You can access all NVIC registers using byte, halfword, and word accesses unless otherwise stated. NVIC registers are located within the SCS (System Control Space). All NVIC registers and system debug registers are little-endian regardless of the endianness state of the processor.

The NVIC supports:

- An implementation-defined number of interrupts, in the range 1-64 interrupts.
- A programmable priority level of 0-3 for each interrupt; a higher level corresponds to a lower priority, so level 0 is the highest interrupt priority.
- Level and pulse detection of interrupt signals.
- Dynamic reprioritization of interrupts.
- Grouping of priority values into group priority and subpriority fields.
- Interrupt tail-chaining.
- An external Non Maskable Interrupt (NMI)
- WIC with Ultra-low Power Sleep mode support

The processor automatically stacks its state on exception entry and unstacks this state on exception exit, with no instruction overhead. This provides low latency exception handling.

*6.2.11.1 Exception Model and System Interrupt Map*

Table 6.2-8 lists the exception model supported by the M251/M252 series. Software can set 4 levels of priority on some of these exceptions as well as on all interrupts. The highest user-configurable priority is denoted as “0x00” and the lowest priority is denoted as “0xC0” (The 6-LSB always 0). The default priority of all the user-configurable interrupts is “0x00”. Note that priority “0” is treated as the fourth priority on the system, after three system exceptions “Reset”, “NMI” and “Hard Fault”.

When any interrupts is accepted, the processor will automatically fetch the starting address of the interrupt service routine (ISR) from a vector table in memory. On system reset, the vector table is fixed at address 0x00000000. Privileged software can write to the VTOR to relocate the vector table start address to a different memory location, in the range 0x00000080 to 0x3FFFFFF80,

The vector table contains the initialization value for the stack pointer on reset, and the entry point addresses for all exception handlers. The vector number on previous page defines the order of entries in the vector table associated with exception handler entry as illustrated in previous section.

Exception Type	Vector Number	Vector Address	Priority
Reset	1	0x00000004	-3
NMI	2	0x00000008	-2
Hard Fault	3	0x0000000C	-1
Reserved	4~ 10		Reserved
SVCall	11	0x0000002C	Configurable
Reserved	12~13		Reserved
PendSV	14	0x00000038	Configurable

SysTick	15	0x0000003C	Configurable
Interrupt (IRQ0 ~ IRQ63)	16 ~ 63	0x00000000 + (Vector Number)*4	Configurable

Table 6.2-8 Exception Model

Vector Number	Interrupt Number (Bit In Interrupt Registers)	Interrupt Name	Interrupt Description
0 ~ 15	-	-	System exceptions
16	0	BODOUT	Brown-Out low voltage detected interrupt
17	1	IRC_INT	IRC TRIM interrupt
18	2	PWRWU_INT	Clock controller interrupt for chip wake-up from power-down state
19	3	Reserved	Reserved
20	4	CLKFAIL	Clock fail detected interrupt
21	5	Reserved	Reserved
22	6	RTC_INT	Real time clock interrupt
23	7	TAMPER_INT	Backup register tamper interrupt
24	8	WDT_INT	Watchdog Timer interrupt
25	9	WWDT_INT	Window Watchdog Timer interrupt
26	10	EINT0	External interrupt from PA.0, PD.2 or PE.4 pins
27	11	EINT1	External interrupt from PB.0, PD.3 or PE.5 pins
28	12	EINT2	External interrupt from PC.0 pin
29	13	EINT3	External interrupt from PD.0 pin
30	14	EINT4	External interrupt from PE.0 pin
31	15	EINT5	External interrupt from PF.0 pin
32	16	GPA_INT	External interrupt from PA[15:0] pin
33	17	GPB_INT	External interrupt from PB[15:0] pin
34	18	GPC_INT	External interrupt from PC[15:0] pin
35	19	GPD_INT	External interrupt from PD[15:0] pin
36	20	GPE_INT	External interrupt from PE[15:0] pin
37	21	GPF_INT	External interrupt from PF[15:0] pin
38	22	QSPIO_INT	QSPIO interrupt
39	23	SPIO_INT	SPIO interrupt
40	24	BRAKE0_INT	PWM0 brake interrupt
41	25	PWM0_P0_INT	PWM0 pair 0 interrupt
42	26	PWM0_P1_INT	PWM0 pair 1 interrupt

43	27	PWM0_P2_INT	PWM0 pair 2 interrupt
44	28	BRAKE1_INT	PWM1 brake interrupt
45	29	PWM1_P0_INT	PWM1 pair 0 interrupt
46	30	PWM1_P1_INT	PWM1 pair 1 interrupt
47	31	PWM1_P2_INT	PWM1 pair 2 interrupt
48	32	TMR0_INT	Timer 0 interrupt
49	33	TMR1_INT	Timer 1 interrupt
50	34	TMR2_INT	Timer 2 interrupt
51	35	TMR3_INT	Timer 3 interrupt
52	36	UART0_INT	UART0 interrupt
53	37	UART1_INT	UART1 interrupt
54	38	I2C0_INT	I2C0 interrupt
55	39	I2C1_INT	I2C1 interrupt
56	40	PDMA_INT	PDMA interrupt
57	41	DAC_INT	DAC interrupt
58	42	EADC_INT	EADC interrupt source 0
59	43	EADC1_INT	EADC interrupt source 1
60	44	ACMP01_INT	ACMP0 and ACMP1 interrupt
61	45	BPWM0	BPWM0 interrupt
62	46	EADC_INT2	EADC interrupt source 2
63	47	EADC_INT	EADC interrupt source 3
64	48	UART2_INT	UART2 interrupt
65	49	Reserved	Reserved
66	50	USCI0	USCI0 interrupt
67	51	Reserved	Reserved
68	52	USCI1	USCI1 interrupt
69	53	USB_INT	USB device interrupt
70	54	BPWM1	BPWM1
71	55	Reserved	Reserved
72	56	Reserved	Reserved
73	57	Reserved	Reserved
74	58	SC0_INT	Smart card host 0 interrupt
75	59	RTCLVR_INT	RTC LVR interrupt
76	60	USCI2	USCI2 interrupt
77	61	Reserved	Reserved

78	62	OPA0	OPA0 interrupt
79	63	Reserved	Reserved

Table 6.2-9 Interrupt Number Table

6.2.11.2 Operation Description

NVIC interrupts can be enabled and disabled by writing to their corresponding Interrupt Set-Enable or Interrupt Clear-Enable register bit-field. The registers use a write-1-to-enable and write-1-to-clear policy, both registers reading back the current enabled state of the corresponding interrupts. When an interrupt is disabled, interrupt assertion will cause the interrupt to become Pending, however, the interrupt will not activate. If an interrupt is Active when it is disabled, it remains in its Active state until cleared by reset or an exception return. Clearing the enable bit prevents new activations of the associated interrupt.

NVIC interrupts can be pended/un-pended using a complementary pair of registers to those used to enable/disable the interrupts, named the Set-Pending Register and Clear-Pending Register respectively. The registers use a write-1-to-enable and write-1-to-clear policy, both registers reading back the current pended state of the corresponding interrupts. The Clear-Pending Register has no effect on the execution status of an Active interrupt.

NVIC interrupts are prioritized by updating an 8-bit field within a 32-bit register (each register supporting four interrupts).

The general registers associated with the NVIC are all accessible from a block of memory in the System Control Space and will be described in next section.

## 6.3 Clock Controller

### 6.3.1 Overview

The clock controller generates clocks for the whole chip, including system clocks and all peripheral clocks. The clock controller also implements the power control function with the individually clock ON/OFF control, clock source selection and a clock divider. The chip will not enter Power-down mode until CPU sets the Power-down enable bit PDEN(CLK\_PWRCTL[7]) and Cortex®-M23 core executes the WFI instruction. After that, chip enters Power-down mode and wait for wake-up interrupt source triggered to leave Power-down mode. In Power-down mode, the clock controller turns off the 4~32 MHz external high speed crystal (HXT), 48 MHz internal high speed RC oscillator (HIRC) and 4 MHz internal median speed RC oscillator (MIRC) to reduce the overall system power consumption Figure 6.3-1 shows the clock generator and the overview of the clock source control.

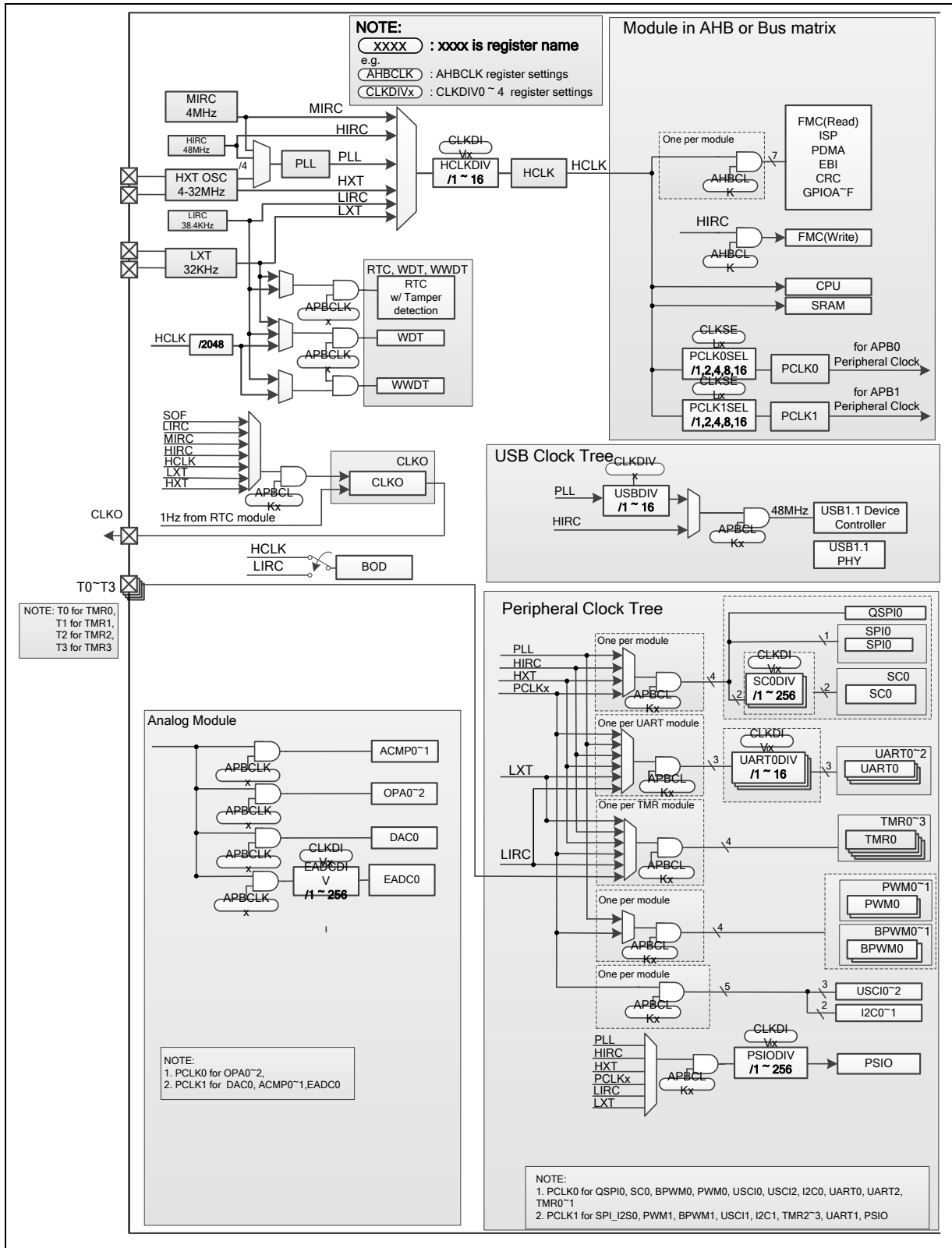

Figure 6.3-1 Clock Generator Global View Diagram

6.3.2 Clock Generator

The clock generator consists of 6 clock sources, which are listed below:

- 32.768 kHz external low speed crystal oscillator (LXT)
- 4~32 MHz external high speed crystal oscillator (HXT)
- Programmable PLL output clock frequency (PLLFOUT) - PLL source can be selected from external 4~32 MHz external high speed crystal (HXT), 48 MHz internal high speed oscillator (HIRC/4) or 4 MHz internal medium speed oscillator (MIRC)
- 48 MHz internal high speed RC oscillator (HIRC)
- 38.4 kHz internal low speed RC oscillator (LIRC)
- 4 MHz internal medium speed oscillator (MIRC)

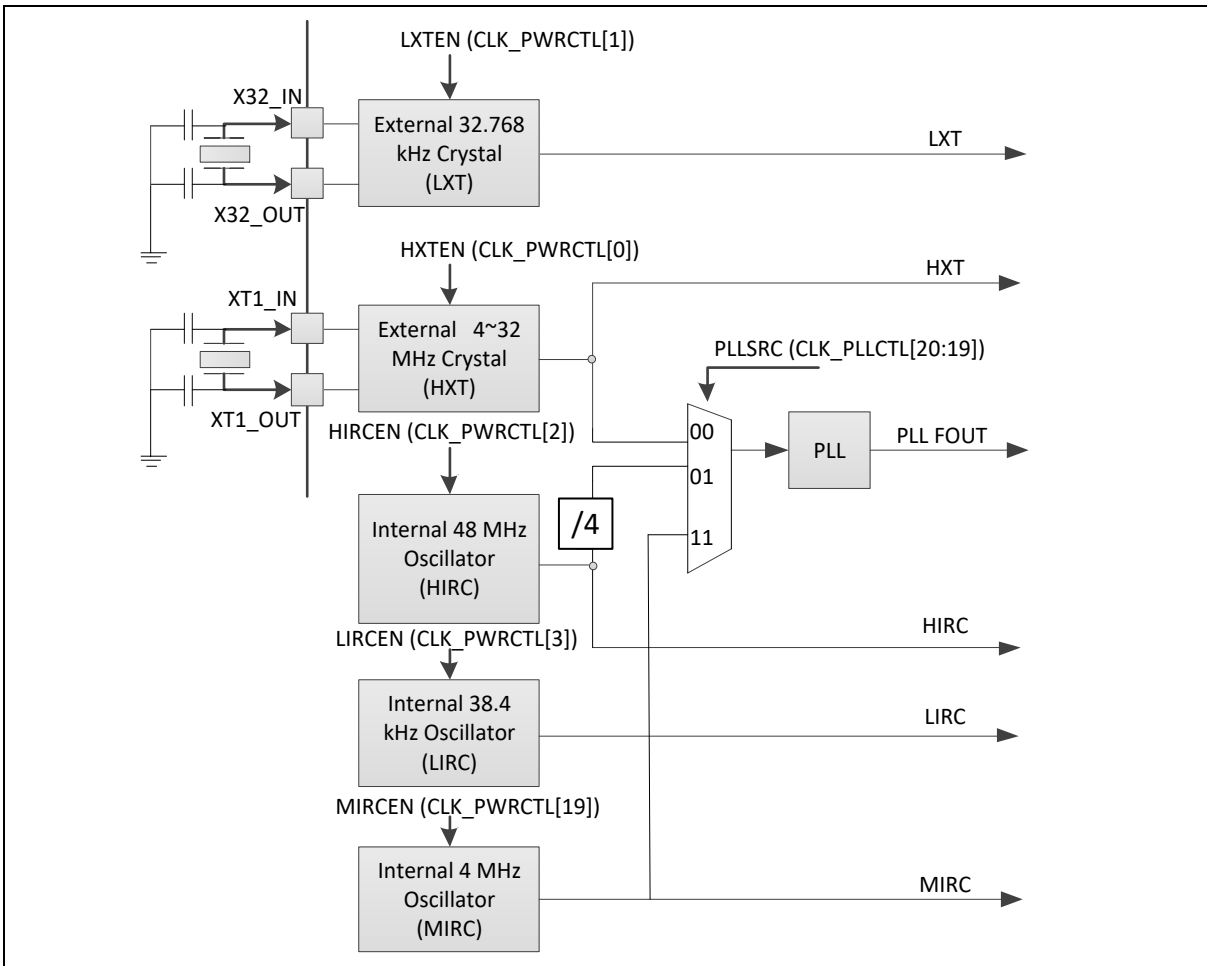

Figure 6.3-2 Clock Generator Block Diagram

### 6.3.3 System Clock and SysTick Clock

The system clock has 6 clock sources, which are generated from clock generator block. The clock source switch depends on the register HCLKSEL (CLK\_CLKSEL0[2:0]). The block diagram is shown in Figure 6.3-3

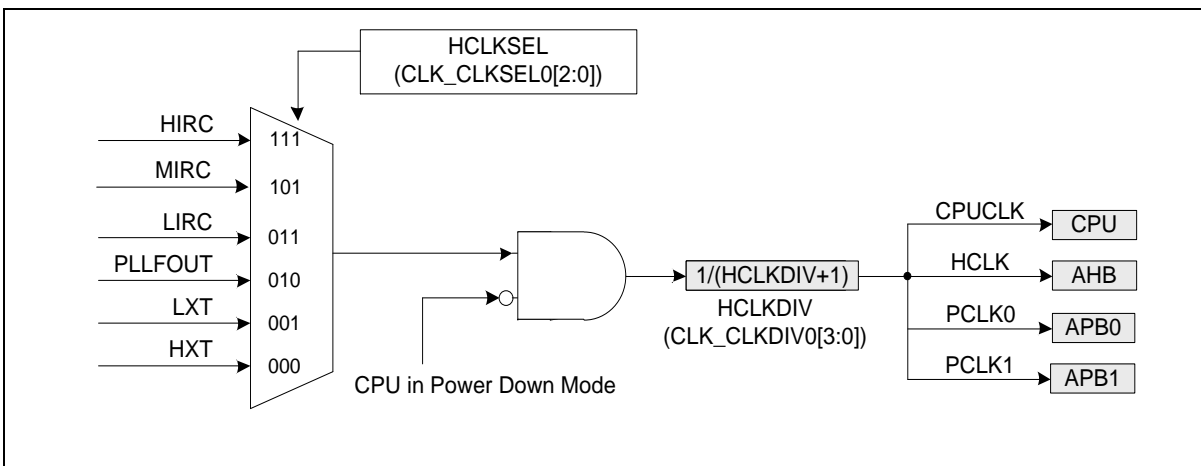

Figure 6.3-3 System Clock Block Diagram

There are two clock fail detectors to observe HXT and LXT clock source and they have individual enable and interrupt control. When HXT detector is enabled, the MIRC clock is enabled automatically. When LXT detector is enabled, the LIRC clock is enabled automatically.

When HXT clock detector is enabled, the system clock will auto switch to MIRC if HXT clock stop being detected on the following condition: system clock source comes from HXT or system clock source comes from PLL with HXT as the input of PLL. If HXT clock stop condition is detected, the HXTFIF (CLK\_CLKDSTS[0]) is set to 1 and chip will enter interrupt if HXTFIE (CLK\_CLKDCTL[5]) is set to 1. User can try to recover HXT by disable HXT and enable HXT again to check if the clock stable bit is set to 1 or not. If HXT clock stable bit is set to 1, it means HXT is recover to oscillate after re-enable action and user can switch system clock to HXT again.

The HXT clock stop detect and system clock switch to MIRC procedure is shown in Figure 6.3-4.

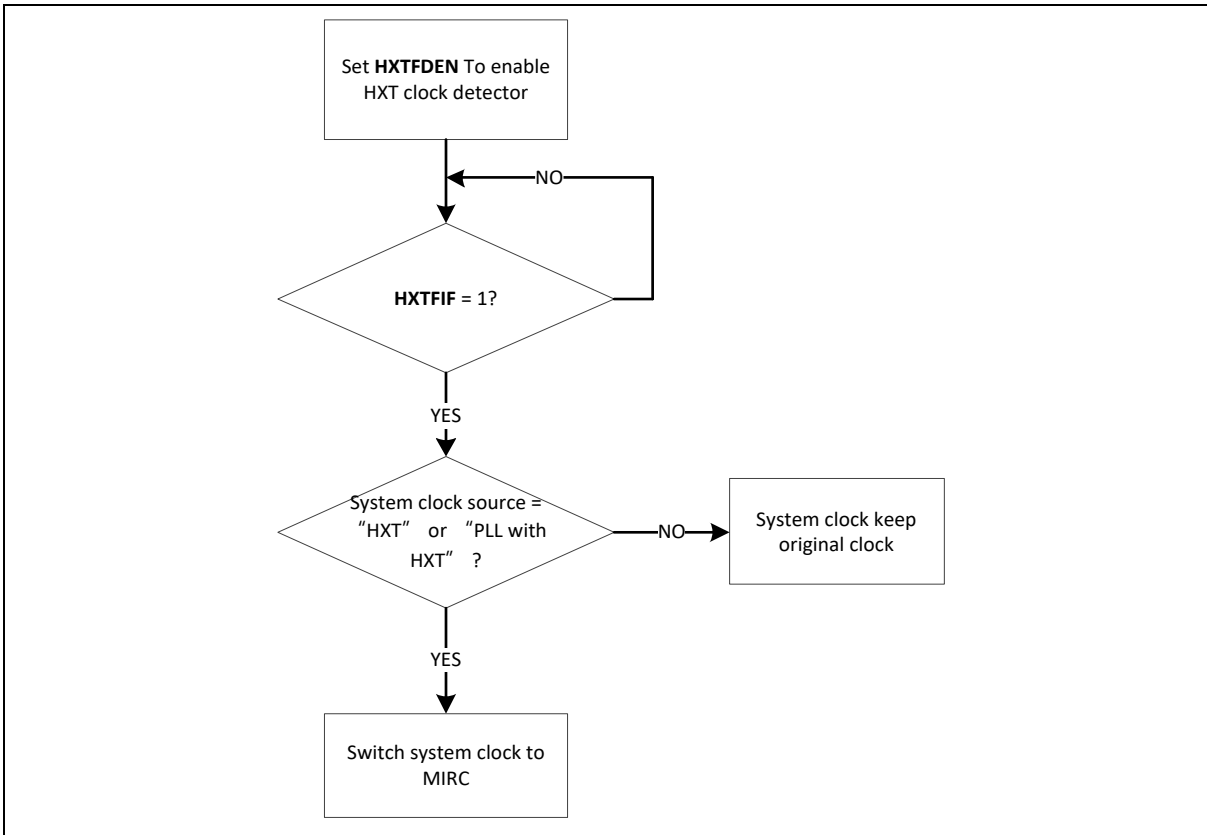

Figure 6.3-4 HXT Stop Protect Procedure

The clock source of SysTick in Cortex®-M23 core can use CPU clock or external clock (SYST\_CTRL[2]). If using external clock, the SysTick clock (STCLK) has 5 clock sources. The clock source switch depends on the setting of the register STCLKSEL (CLK\_CLKSEL0[5:3]). The block diagram is shown in Figure 6.3-5.

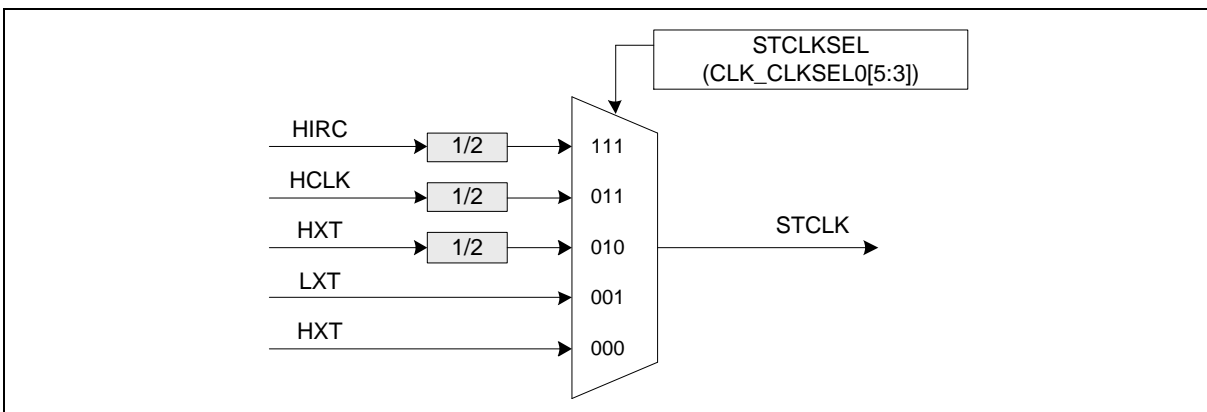

Figure 6.3-5 SysTick Clock Control Block Diagram

### 6.3.4 Peripherals Clock

The peripherals clock has different clock source switch setting, which depends on the different peripheral. Please refer to the CLK\_CLKSEL1 and CLK\_CLKSEL2 register description in 5.3.8.

### 6.3.5 Power-down Mode Clock

When entering Power-down mode, system clocks, some clock sources and some peripheral clocks are disabled. Some clock sources and peripherals clock are still active in Power-down mode.

For these clocks, which still keep active, are listed below:

- Clock Generator
  - 38.4 kHz internal low speed RC oscillator (LIRC) clock
  - 32.768 kHz external low speed crystal oscillator (LXT) clock
- Peripherals Clock, except for HCLK, PCLK0 and PCLK1(When the modules adopt LXT or LIRC as clock source)

### 6.3.6 Clock Output

This device is equipped with a power-of-2 frequency divider which is composed by 16 chained divide-by-2 shift registers. One of the 16 shift register outputs selected by a sixteen to one multiplexer is reflected to CLKO function pin. Therefore there are 16 options of power-of-2 divided clocks with the frequency from  $F_{in}/2^1$  to  $F_{in}/2^{16}$  where  $F_{in}$  is input clock frequency to the clock divider.

The output formula is  $F_{out} = F_{in}/2^{(N+1)}$ , where  $F_{in}$  is the input clock frequency,  $F_{out}$  is the clock divider output frequency and N is the 4-bit value in FREQSEL (CLK\_CLKOCTL[3:0]).

When writing 1 to CLKOEN (CLK\_CLKOCTL[4]), the chained counter starts to count. When writing 0 to CLKOEN (CLK\_CLKOCTL[4]), the chained counter continuously runs till divided clock reaches low state and stays in low state.

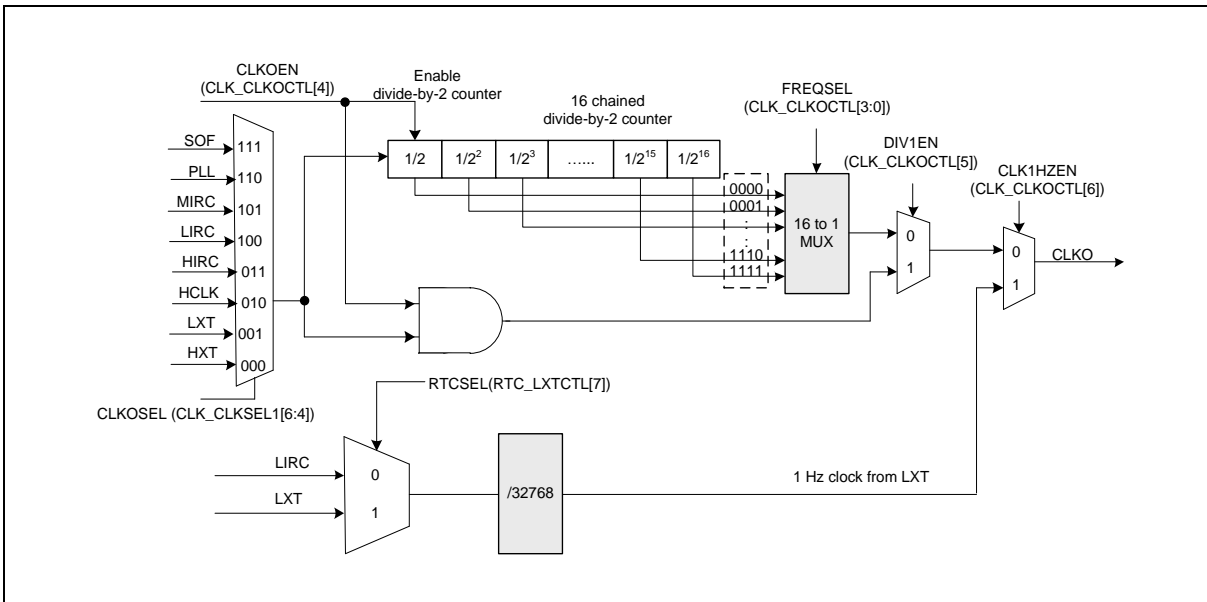

Figure 6.3-6 Clock Output Block Diagram

**6.3.7 USB Clock Source**

The clock source of USB 1.0 is generated from 48Mhz HIRC or programmable PLL output. The generated clocks are shown in Figure 6.3-7.

USBPLLDIV is the clock divider output frequency, the output formula is  $(\text{PLLFOUT frequency}) / (\text{USBDIV} + 1)$ .

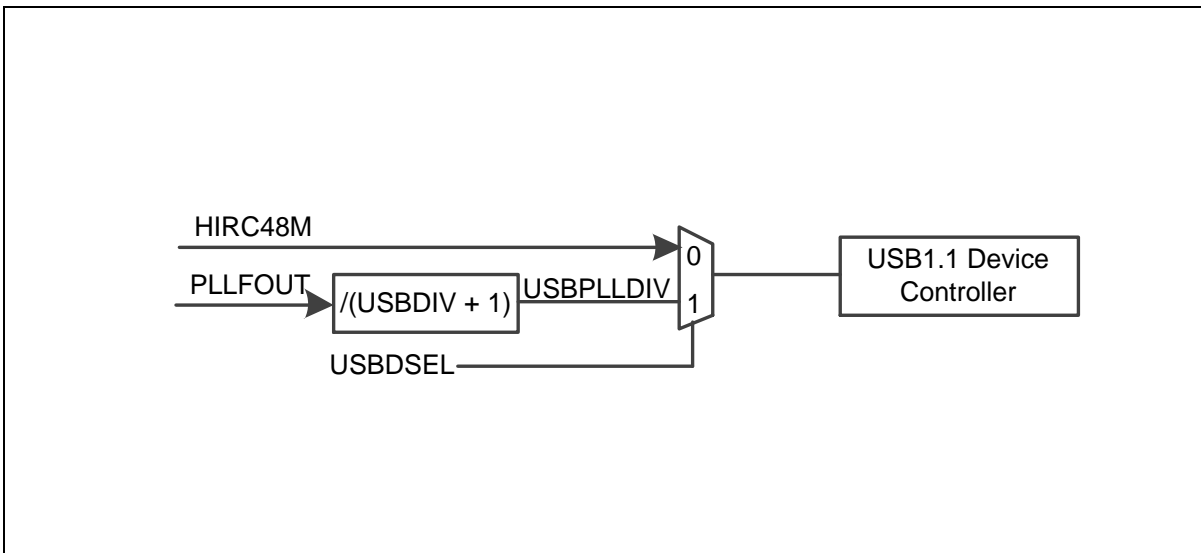

Figure 6.3-7 USB Clock Source

## 6.4 Flash Memory Controller (FMC)

### 6.4.1 Overview

The FMC is equipped with 32/64/128/256 Kbytes on-chip embedded Flash for application. A User Configuration block provides for system initiation. A 4 Kbytes loader ROM (LDRROM) is used for In-System-Programming (ISP) function. XOM (Execution Only Memory) setting block to conceal user program in XOM region. A 512 bytes cache with zero wait cycle is used to improve Flash access performance. This chip also supports In-Application-Programming (IAP) function. User switches the code executing without chip reset after the embedded Flash is updated.

### 6.4.2 Features

- Supports 32/64/128/256 Kbytes application ROM (APROM)
- Supports 4 Kbytes loader ROM (LDRROM)
- Supports 1 XOM (Execution Only Memory) region to conceal user program in APROM
- Supports 12 bytes User Configuration block to control system initiation.
- Supports 512 bytes page erase for all embedded Flash
- Supports 32-bit and multi-word Flash programming function
- Supports CRC32 checksum calculation function
- Supports Flash all one verification function
- Supports embedded SRAM remap to system vector memory
- Supports In-System-Programming (ISP) / In-Application-Programming (IAP) to update embedded Flash memory
- Supports cache memory to improve Flash access performance and reduce power consumption

## 6.5 General Purpose I/O (GPIO)

### 6.5.1 Overview

This chip has up to 85 General Purpose I/O pins to be shared with other function pins depending on the chip configuration. These 85 pins are arranged in 6 ports named as PA, PB, PC, PD, PE, and PF. PA, PB and PE has 16 pins on port. PC has 14 pins on port, PD has 15 pins on port. PF has 8 pins on port. Each of the 85 pins is independent and has the corresponding register bits to control the pin mode function and data.

The I/O type of each of I/O pins can be configured by software individually as Input, Push-pull output, Open-drain output or Quasi-bidirectional mode. After the chip is reset, the I/O mode of all pins are depending on CIOINI (CONFIG0[10]). Each I/O pin has a very weakly individual pull-up resistor which is about 50 k $\Omega$ .

### 6.5.2 Features

- Four I/O modes:
  - Quasi-bidirectional mode
  - Push-Pull Output mode
  - Open-Drain Output mode
  - Input only with high impedance mode
- TTL/Schmitt trigger input selectable
- I/O pin can be configured as interrupt source with edge/level setting
- Supports High Drive and High Slew Rate I/O mode
- Configurable default I/O mode of all pins after reset by CIOINI (CONFIG0[10]) setting
  - CIOINI = 0, all GPIO pins in Quasi-bidirectional mode after chip reset
  - CIOINI = 1, all GPIO pins in input mode after chip reset
- Support independent pull-up and pull-down control
- Enabling the pin interrupt function will also enable the wake-up function
- Improve access efficiency by using single cycle I/O bus

## 6.6 PDMA Controller (PDMA)

### 6.6.1 Overview

The peripheral direct memory access (PDMA) controller is used to provide high-speed data transfer. The PDMA controller can transfer data from one address to another without CPU intervention. This has the benefit of reducing the workload of CPU and keeps CPU resources free for other applications. The PDMA controller has a total of 8 channels and each channel can perform transfer between memory and peripherals or between memory and memory.

### 6.6.2 Features

- Supports up to 8 independently configurable channels
- Supports selectable 2 level of priority (fixed priority or round-robin priority)
- Supports transfer data width of 8, 16, and 32 bits
- Supports source and destination address increment size can be byte, half-word, word or no increment
- Request source can be from software, PSIO, SPI/I<sup>2</sup>S, UART, USCI, EADC, DAC, PWM capture event and TIMER
- Supports Scatter-gather mode to perform sophisticated transfer through the use of the descriptor link list table
- Supports single and burst transfer type
- Supports time-out function on channel 0 and channel 1
- Supports stride function from channel 0 to channel 5

## 6.7 Timer Controller (TMR)

### 6.7.1 Overview

The timer controller includes four 32-bit timers, Timer0 ~ Timer3, allowing user to easily implement a timer control for applications. The timer can perform functions, such as frequency measurement, delay timing, clock generation, and event counting by external input pins, and interval measurement by external capture pins.

The timer controller also provides four PWM generators. Each PWM generator supports one PWM output and two selectable PWM output channels (TMx or TMx\_EXT). The output state of PWM output pin can be control by polarity control, output enable control and output channel select.

### 6.7.2 Features

#### 6.7.2.1 Timer Function Features

- Four sets of 32-bit timers, each timer having one 24-bit up counter and one 8-bit prescale counter
- Independent clock source for each timer
- Provides one-shot, periodic, toggle-output and continuous counting operation modes
- 24-bit up counter value is readable through CNT (TIMERx\_CNT[23:0])
- Supports event counting function
- 24-bit capture value is readable through CAPDAT (TIMERx\_CAP[23:0])
- Supports external capture pin (TMx\_EXT) event for interval measurement
- Supports external capture pin (TMx\_EXT) event to reset 24-bit up counter
- Supports internal clock (HIRC, LIRC, MIRC) and external clock (HXT, LXT) for capture event
- Supports chip wake-up from Idle/Power-down mode if a timer interrupt signal is generated
- Support Timer0 ~ Timer3 time-out interrupt signal or capture interrupt signal to trigger BPWM, PWM, EADC, DAC and PDMA function
- Supports internal capture triggered while internal ACMP output signal transition
- Supports Inter-Timer trigger mode
- Supports event counting source from internal USB SOF signal

#### 6.7.2.2 PWM Function Features

- Supports PWM generator with two selectable output channels
- Supports 16-bit PWM counter
  - Up count operation type
  - One-shot or auto-reload counter operation mode
- Supports 8-bit prescale from 1 to 256
- Supports 16-bit compare register and period register and double buffer for period register and compare register
- Supports tri-state enable and polarity control for each PWM selectable output channels
- Supports interrupt on the following events:
  - PWM period point, up-count compared point events

- Supports wake-up when interrupt occurs when clock source is LXT or LIRC
- PWM can generator output in power down mode
- Supports trigger EADC, PDMA, and DAC on the following events:
  - PWM period point and up-count compared point events

## 6.8 Watchdog Timer (WDT)

### 6.8.1 Overview

The Watchdog Timer (WDT) is used to perform a system reset when system runs into an unknown state. This prevents system from hanging for an infinite period of time. Besides, this Watchdog Timer supports the function to wake up system from Idle/Power-down mode.

### 6.8.2 Features

- 20-bit free running up counter for WDT time-out interval
- Selectable time-out interval ( $2^4 \sim 2^{20}$ ) and the time-out interval is 417us ~ 27.3 s if WDT\_CLK = 38.4 kHz (LIRC).
- System kept in reset state for a period of  $(1 / \text{WDT\_CLK}) * 63$
- Supports selectable WDT reset delay period, including 1026, 130, 18 or 3 WDT\_CLK reset delay period
- Supports to force WDT enabled after chip powered on or reset by setting CWDTEN[2:0] in Config0 register
- Supports WDT time-out wake-up function only if WDT clock source is selected as 38.4 kHz LIRC or LXT.

## 6.9 Window Watchdog Timer (WWDT)

### 6.9.1 Overview

The Window Watchdog Timer (WWDT) is used to perform a system reset within a specified window period to prevent software running to uncontrollable status by any unpredictable condition.

### 6.9.2 Features

- 6-bit down counter value (CNTDAT, WWDT\_CNT[5:0]) and 6-bit compare value (CMPDAT, WWDT\_CTL[21:16]) to make the WWDT time-out window period flexible
- Supports 4-bit value (PSCSEL, WWDT\_CTL[11:8]) to programmable maximum 11-bit prescale counter period of WWDT counter
- WWDT counter suspends in Idle/Power-down mode

## 6.10 Real Time Clock (RTC)

### 6.10.1 Overview

The Real Time Clock (RTC) controller provides the real time and calendar message. The RTC offers programmable time tick and alarm match interrupts. The data format of time and calendar messages are expressed in BCD format. A digital frequency compensation feature is available to compensate external crystal oscillator frequency accuracy.

### 6.10.2 Features

- Supports external power pin  $V_{BAT}$ .
- Supports real time counter in RTC\_TIME (hour, minute, second) and calendar counter in RTC\_CAL (year, month, day) for RTC time and calendar check.
- Supports alarm time (hour, minute, second) and calendar (year, month, day) settings in RTC\_TALM and RTC\_CALM.
- Supports alarm time (hour, minute, second) and calendar (year, month, day) mask enable in RTC\_TAMSK and RTC\_CAMSK.
- Selectable 12-hour or 24-hour time scale in RTC\_CLKFMT register.
- 
- Supports Leap Year indication in RTC\_LEAPYEAR register.
- Supports Day of the Week counter in RTC\_WEEKDAY register.
- Frequency of RTC clock source compensate by RTC\_FREQADJ register.
- All time and calendar message expressed in BCD format.
- Supports periodic RTC Time Tick interrupt with 8 period interval options 1/128, 1/64, 1/32, 1/16, 1/8, 1/4, 1/2 and 1 second.
- Supports RTC Time Tick and Alarm Match interrupt.
- Supports 1 Hz clock output.
- Supports chip wake-up from Idle or Power-down mode while a RTC interrupt signal is generated.
- Supports Daylight Saving Time software control in RTC\_DSTCTL.
- Supports one tamper pin.
- Supports 20 bytes spare registers and tamper-pin detection to clear the content of these spare registers.

## 6.11 Basic PWM Generator and Capture Timer (BPWM)

### 6.11.1 Overview

The chip provides two BPWM generators. Each BPWM supports 6 channels of BPWM output or input capture. There is a 12-bit prescaler to support flexible clock to the 16-bit BPWM counter with 16-bit comparator. The BPWM counter supports up, down and up-down counter types, all 6 channels share one counter. BPWM uses the comparator compared with counter to generate events. These events are used to generate BPWM pulse, interrupt and trigger signal for EADC to start conversion. For BPWM output control unit, it supports polarity output, independent pin mask and tri-state output enable.

The BPWM generator also supports input capture function to latch BPWM counter value to corresponding register when input channel has a rising transition, falling transition or both transition is happened.

### 6.11.2 Features

#### 6.11.2.1 BPWM Function Features

- Supports maximum clock frequency up to maximum PLL frequency.
- Supports up to two BPWM modules; each module provides 6 output channels
- Supports independent mode for BPWM output/Capture input channel
- Supports 12-bit prescaler from 1 to 4096
- Supports 16-bit resolution BPWM counter; each module provides 1 BPWM counter
  - Up, down and up/down counter operation type
- Supports mask function and tri-state enable for each BPWM pin
- Supports interrupt in the following events:
  - BPWM counter matches 0, period value or compared value
- Supports trigger EADC in the following events:
  - BPWM counter matches 0, period value or compared value

#### 6.11.2.2 Capture Function Features

- Supports up to 12 capture input channels with 16-bit resolution
- Supports rising or falling capture condition
- Supports input rising/falling capture interrupt
- Supports rising/falling capture with counter reload option

## 6.12 PWM Generator and Capture Timer (PWM)

### 6.12.1 Overview

The chip provides two PWM generators — PWM0 and PWM1. Each PWM supports 6 channels of PWM output or input capture. There is a 12-bit prescaler to support flexible clock to the 16-bit PWM counter with 16-bit comparator. The PWM counter supports up, down and up-down counter types. PWM uses comparator compared with counter to generate events. These events use to generate PWM pulse, interrupt and trigger signal for ADC to start conversion.

The PWM generator supports two standard PWM output modes: Independent mode and Complementary mode, they have difference architecture. In Complementary mode, there are two comparators to generate various PWM pulse with 12-bit dead-time generator. For PWM output control unit, it supports polarity output, independent pin mask and brake functions.

The PWM generator also supports input capture function to latch PWM counter value to the corresponding register when input channel has a rising transition, falling transition or both transition is happened. Capture function also support PDMA to transfer captured data to memory.

### 6.12.2 Features

#### 6.12.2.1 PWM function features

- Supports maximum clock frequency up to maximum PLL frequency
- Supports up to two PWM modules, each module provides 6 output channels
- Supports independent mode for PWM output/Capture input channel
- Supports complementary mode for 3 complementary paired PWM output channel
  - Dead-time insertion with 12-bit resolution
  - Two compared values during one period
- Supports 12-bit prescaler from 1 to 4096
- Supports 16-bit resolution PWM counter
  - Up, down and up/down counter operation type
- Supports mask function and tri-state enable for each PWM pin
- Supports brake function
  - Brake source from pin and system safety events (clock failed, Brown-out detection and CPU lockup)
  - Noise filter for brake source from pin
  - Edge detect brake source to control brake state until brake interrupt cleared
  - Level detect brake source to auto recover function after brake condition removed
- Supports interrupt on the following events:
  - PWM counter matches 0, period value or compared value
  - Brake condition happened
- Supports trigger ADC on the following events:
  - PWM counter matches 0, period value or compared value

#### 6.12.2.2 Capture Function Features

- Supports up to 12 capture input channels with 16-bit resolution

- Supports rising or falling capture condition
- Supports input rising/falling capture interrupt
- Supports rising/falling capture with counter reload option
- Supports PDMA transfer function for PWM all channels

## 6.13 UART Interface Controller (UART)

### 6.13.1 Overview

The chip provides three channels of Universal Asynchronous Receiver/Transmitters (UART). The UART controller performs Normal Speed UART and supports flow control function. The UART controller performs a serial-to-parallel conversion on data received from the peripheral and a parallel-to-serial conversion on data transmitted from the CPU. Each UART controller channel supports ten types of interrupts. The UART controller also supports IrDA SIR, LIN, RS-485 and Single-wire function modes and auto-baud rate measuring function.

### 6.13.2 Features

- Full-duplex asynchronous communications
- Separates receive and transmit 16/16 bytes entry FIFO for data payloads
- Supports hardware auto-flow control
- Programmable receiver buffer trigger level
- Supports programmable baud rate generator for each channel individually
- Supports nCTS, incoming data, Received Data FIFO reached threshold and RS-485 Address Match (AAD mode) wake-up function
- Supports 8-bit receiver buffer time-out detection function
- Programmable transmitting data delay time between the last stop and the next START bit by setting DLY (UART\_TOUT [15:8])
- Supports Auto-Baud Rate measurement and baud rate compensation function
  - Support 9600 bps for UART\_CLK is selected LXT.
- Supports break error, frame error, parity error and receive/transmit buffer overflow detection function
- Fully programmable serial-interface characteristics
  - Programmable number of data bit, 5-, 6-, 7-, 8- bit character
  - Programmable PARITY bit, even, odd, no parity or stick PARITY bit generation and detection
  - Programmable STOP bit, 1, 1.5, or 2 STOP bit generation
- Supports IrDA SIR function mode
  - Supports for 3/16 bit duration for normal mode
- Supports LIN function mode (Only UART0 with LIN function)
  - Supports LIN master/slave mode
  - Supports programmable break generation function for transmitter
  - Supports break detection function for receiver
- Supports RS-485 function mode
  - Supports RS-485 9-bit mode
  - Supports hardware or software enables to program nRTS pin to control RS-485 transmission direction
- Supports PDMA transfer function
- Support Single-wire function mode.

UART Feature	UART0	UART1/UART2	SC_UART	USCI-UART
FIFO	16 Bytes	16 Bytes	4 Bytes	TX: 1byte RX: 2byte
Auto Flow Control (CTS/RTS)	√	√	-	√
IrDA	√	√	-	-
LIN	√	-	-	-
RS-485 Function Mode	√	√	-	√
nCTS Wake-up	√	√	-	√
Incoming Data Wake-up	√	√	-	√
Received Data FIFO reached threshold Wake-up	√	√	-	-
RS-485 Address Match (AAD mode) Wake-up	√	√	-	-
Auto-Baud Rate Measurement	√	√	-	√
STOP bit Length	1, 1.5, 2 bit	1, 1.5, 2 bit	1, 2 bit	1, 2 bit
Word Length	5, 6, 7, 8 bits	5, 6, 7, 8 bits	5, 6, 7, 8 bits	6~13 bits
Even / Odd Parity	√	√	√	√
Stick Bit	√	√	-	-
<b>Note:</b> √= Supported				

Table 6.13-1 UART Feature List

## 6.14 Smart Card Host Interface (SC)

### 6.14.1 Overview

The Smart Card Interface controller (SC controller) is based on ISO/IEC 7816-3 standard and fully compliant with PC/SC Specifications. It also provides status of card insertion/removal.

### 6.14.2 Features

- ISO 7816-3 T = 0, T = 1 compliant
- EMV2000 compliant
- One ISO 7816-3 port
- Separates receive/transmit 4 byte entry FIFO for data payloads
- Programmable transmission clock frequency
- Programmable receiver buffer trigger level
- Programmable guard time selection (11 ETU ~ 267 ETU)
- One 24-bit timer and two 8-bit timers for Answer to Request (ATR) and waiting times processing
- Supports auto direct / inverse convention function
- Supports transmitter and receiver error retry and error number limiting function
- Supports hardware activation sequence process, and the time between PWR on and CLK start is configurable
- Supports hardware warm reset sequence process
- Supports hardware deactivation sequence process
- Supports hardware auto deactivation sequence when detected the card removal
- Supports UART mode
  - Full duplex, asynchronous communications
  - Separates receiving / transmitting 4 bytes entry FIFO for data payloads
  - Supports programmable baud rate generator
  - Supports programmable receiver buffer trigger level
  - Programmable transmitting data delay time between the last stop bit leaving the TX-FIFO and the de-assertion by setting EGT (SCn\_EGT[7:0])
  - Programmable even, odd or no parity bit generation and detection
  - Programmable stop bit, 1- or 2- stop bit generation

## 6.15 Serial Peripheral Interface (SPI)

### 6.15.1 Overview

The Serial Peripheral Interface (SPI) applies to synchronous serial data communication and allows full duplex transfer. Devices communicate in Master/Slave mode with the 4-wire bi-direction interface. The chip contains one of SPI controller performing a serial-to-parallel conversion on data received from a peripheral device, and a parallel-to-serial conversion on data transmitted to a peripheral device. Each SPI controller can be configured as a master or a slave device and supports the PDMA function to access the data buffer. Each SPI controller also supports I<sup>2</sup>S mode to connect external audio CODEC.

### 6.15.2 Features

- SPI Mode
  - Support one SPI controller
  - Supports Master or Slave mode operation
  - Configurable bit length of a transaction word from 8 to 32-bit
  - Provides separate 4-level depth transmit and receive FIFO buffers
  - Supports MSB first or LSB first transfer sequence
  - Supports Byte Reorder function
  - Supports Byte or Word Suspend mode
  - Supports PDMA transfer
  - Supports one data channel half-duplex transfer
  - Supports receive-only mode
- I<sup>2</sup>S Mode
  - Supports Master or Slave
  - Capable of handling 8-, 16-, 24- and 32-bit word sizes
  - Each provides two 4-level FIFO data buffers, one for transmitting and the other for receiving
  - Supports monaural and stereo audio data
  - Supports PCM mode A, PCM mode B, I<sup>2</sup>S and MSB justified data format
  - Supports two PDMA requests, one for transmitting and the other for receiving

## 6.16 Quad Serial Peripheral Interface (QSPI)

### 6.16.1 Overview

The Quad Serial Peripheral Interface (QSPI) applies to synchronous serial data communication and allows full duplex transfer. Devices communicate in Master/Slave mode with the 4-wire bi-direction interface. The chip contains one QSPI controller performing a serial-to-parallel conversion on data received from a peripheral device, and a parallel-to-serial conversion on data transmitted to a peripheral device.

The QSPI controller supports 2-bit Transfer mode to perform full-duplex 2-bit data transfer and also supports Dual and Quad I/O Transfer mode and the controller supports the PDMA function to access the data buffer.

### 6.16.2 Features

- Supports one QSPI controller
- Supports Master or Slave mode operation
- Supports 2-bit Transfer mode
- Supports Dual and Quad I/O Transfer mode
- Configurable bit length of a transaction word from 8 to 32-bit
- Provides separate 8-level depth transmit and receive FIFO buffers
- Supports MSB first or LSB first transfer sequence
- Supports Byte Reorder function
- Supports Byte or Word Suspend mode
- Supports PDMA transfer
- Supports 3-Wire, no slave selection signal, bi-direction interface
- Supports one data channel half-duplex transfer
- Supports receive-only mode

## 6.17 I<sup>2</sup>C Serial Interface Controller (I<sup>2</sup>C)

### 6.17.1 Overview

I<sup>2</sup>C is a two-wire, bi-directional serial bus that provides a simple and efficient method of data exchange between devices. The I<sup>2</sup>C standard is a true multi-master bus including collision detection and arbitration that prevents data corruption if two or more masters attempt to control the bus simultaneously.

There are two sets of I<sup>2</sup>C controllers that support Power-down wake-up function.

### 6.17.2 Features

The I<sup>2</sup>C bus uses two wires (SDA and SCL) to transfer information between devices connected to the bus. The main features of the I<sup>2</sup>C bus include:

- Supports up to two I<sup>2</sup>C ports
- Master/Slave mode
- Bidirectional data transfer between masters and slaves
- Multi-master bus (no central master)
- Supports Standard mode (100 kbps), Fast mode (400 kbps) and Fast mode plus (1 Mbps)
- Arbitration between simultaneously transmitting masters without corruption of serial data on the bus
- Serial clock synchronization allow devices with different bit rates to communicate via one serial bus
- Serial clock synchronization used as a handshake mechanism to suspend and resume serial transfer
- Built-in 14-bit time-out counter requesting the I<sup>2</sup>C interrupt if the I<sup>2</sup>C bus hangs up and timer-out counter overflow
- Programmable clocks allow for versatile rate control
- Supports 7-bit addressing and 10-bit addressing mode
- Supports multiple address recognition ( four slave address with mask option)
- Supports Power-down wake-up function
- Supports PDMA with one buffer capability
- Supports setup/hold time programmable
- Supports Bus Management (SM/PM compatible) function.

## 6.18 USCI - Universal Serial Control Interface Controller (USCI)

### 6.18.1 Overview

The Universal Serial Control Interface (USCI) is a flexible interface module covering several serial communication protocols. The user can configure this controller as UART, SPI, or I<sup>2</sup>C functional protocol.

### 6.18.2 Features

The controller can be individually configured to match the application needs. The following protocols are supported:

- UART
- SPI
- I<sup>2</sup>C

## 6.19 USCI – UART Mode

### 6.19.1 Overview

The asynchronous serial channel UART covers the reception and the transmission of asynchronous data frames. It performs a serial-to-parallel conversion on data received from the peripheral, and a parallel-to-serial conversion on data transmitted from the controller. The receiver and transmitter being independent, frames can start at different points in time for transmission and reception.

The UART controller also provides auto flow control. There are three conditions to wake-up the system.

### 6.19.2 Features

- Supports one transmit buffer and two receive buffer for data payload
- Supports hardware auto flow control function
- Supports programmable baud-rate generator
- Support 9-bit Data Transfer (Support 9-bit RS-485)
- Baud rate detection possible by built-in capture event of baud rate generator
- Supports PDMA capability
- Supports Wake-up function (Data and nCTS Wakeup Only)

## 6.20 USCI - SPI Mode

### 6.20.1 Overview

The SPI protocol of USCI controller applies to synchronous serial data communication and allows full duplex transfer. It supports both master and Slave operation mode with the 4-wire bi-direction interface. SPI mode of USCI controller performs a serial-to-parallel conversion on data received from a peripheral device, and a parallel-to-serial conversion on data transmitted to a peripheral device. The SPI mode is selected by FUNMODE (USPI\_CTL[2:0]) = 0x1

This SPI protocol can operate as master or Slave mode by setting the SLAVE (USPI\_PROTCTL[0]) to communicate with the off-chip SPI Slave or master device. The application block diagrams in master and Slave mode are shown below.

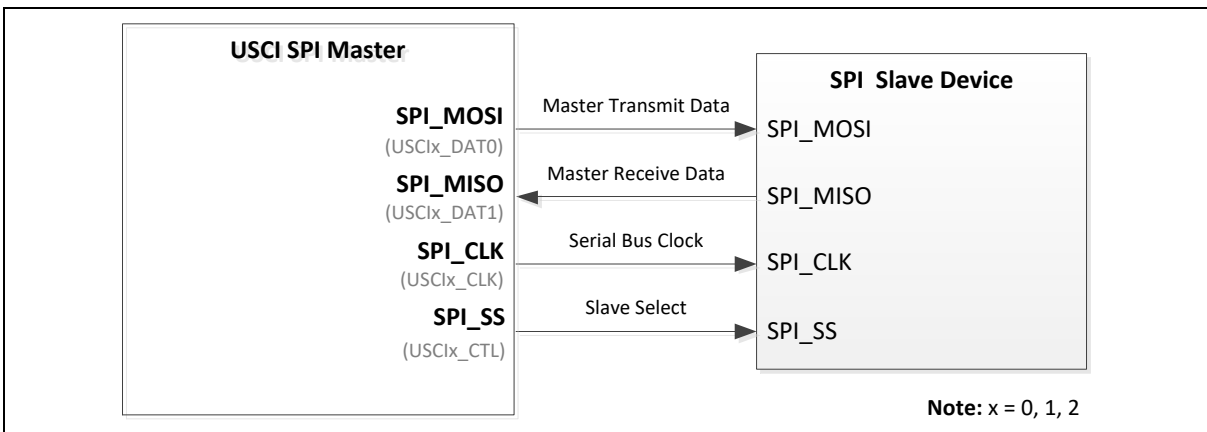

Figure 6.20-1 SPI Master Mode Application Block Diagram

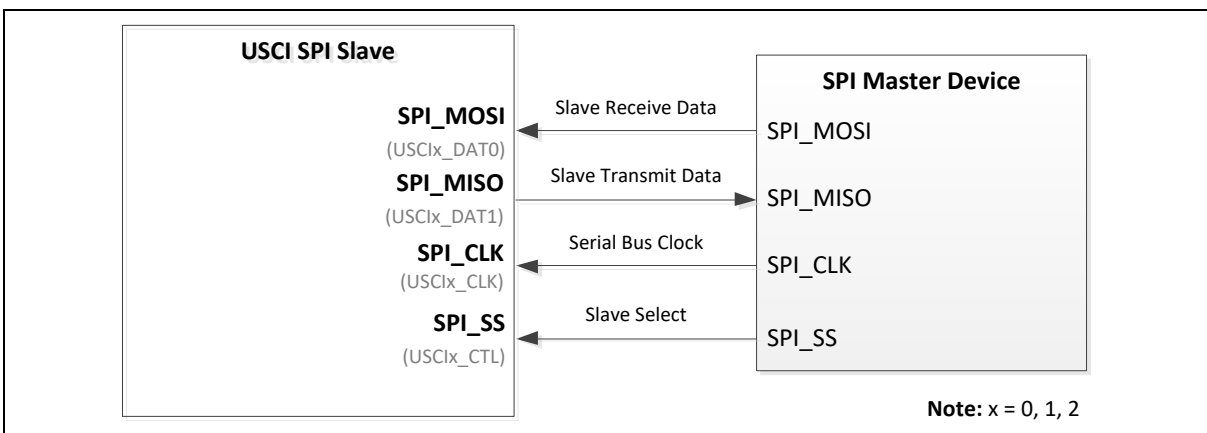

Figure 6.20-2 SPI Slave Mode Application Block Diagram

### 6.20.2 Features

- Configurable bit length of a transfer word from 4 to 16-bit
- Supports one transmit buffer and two receive buffers for data payload
- Supports MSB first or LSB first transfer sequence
- Supports Word Suspend function
- Supports PDMA transfer

- Supports 3-wire, no slave select signal, bi-direction interface
- Supports wake-up function by slave select signal in Slave mode
- Supports one data channel half-duplex transfer

## 6.21 USCI - I<sup>2</sup>C Mode

### 6.21.1 Overview

On I<sup>2</sup>C bus, data is transferred between a Master and a Slave. Data bits transfer on the SCL and SDA lines are synchronously on a byte-by-byte basis. Each data byte is 8-bit. There is one SCL clock pulse for each data bit with the MSB being transmitted first, and an acknowledge bit follows each transferred byte. Each bit is sampled during the high period of SCL; therefore, the SDA line may be changed only during the low period of SCL and must be held stable during the high period of SCL. A transition on the SDA line while SCL is high is interpreted as a command (START or STOP). Please refer to Figure 6.21-1 for more detailed I<sup>2</sup>C BUS Timing.

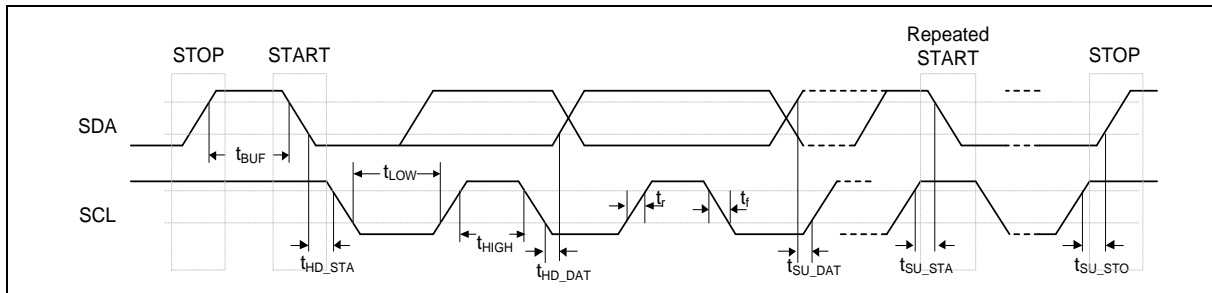

Figure 6.21-1 I<sup>2</sup>C Bus Timing

The device's on-chip I<sup>2</sup>C provides the serial interface that meets the I<sup>2</sup>C bus standard mode specification. The I<sup>2</sup>C port handles byte transfers autonomously. The I<sup>2</sup>C mode is selected by FUNMODE (UI2C\_CTL [2:0]) = 100B. When enable this port, the USCI interfaces to the I<sup>2</sup>C bus via two pins: SDA and SCL. When I/O pins are used as I<sup>2</sup>C ports, user must set the pins function to I<sup>2</sup>C in advance.

**Note:** Pull-up resistor is needed for I<sup>2</sup>C operation because the SDA and SCL are set to open-drain pins when USCI is selected to I<sup>2</sup>C operation mode.

### 6.21.2 Features

- Full master and slave device capability
- Supports of 7-bit addressing, as well as 10-bit addressing
- Communication in standard mode (100 kBit/s) or in fast mode (up to 400 kBit/s)
- Supports multi-master bus
- Supports one transmit buffer and two receive buffer for data payload
- Supports 10-bit bus time-out capability
- Supports bus monitor mode.
- Supports Power down wake-up by data toggle or address match
- Supports setup/hold time programmable
- Supports multiple address recognition (two slave address with mask option)

## 6.22 Programmable Serial IO (PSIO)

### 6.22.1 Overview

Programmable Serial I/O (PSIO) provides a simple way to implement simple serial signal processing, e.g. UART and IR. The PSIO can control when the pin will output high or low and how long the pin need to output high or low. It also provides the easy way to sample the pin state.

### 6.22.2 Features

- Supports up to 8 PSIO pins, from PSIO pin0 to PSIO pin7
- Supports 6 clock sources, they are HXT, LXT, HIRC, LIRC, PLL, PCLK1
- Supports one clock divider, which can be divided from 1 to 255
- Supports slot controller for timing sequence control
  - Supports 4 slot controllers, 8 slots in each slot controller
  - Supports counting from 1 PSIO clock to 15 PSIO clocks in each slot
  - Supports 3 slot repeat modes:
    - ◆ Normal repeat mode
    - ◆ Normal repeat mode with infinity loops
    - ◆ Whole repeat mode
  - Supports 4 slot trigger conditions:
    - ◆ Triggered by software
    - ◆ Triggered by falling edge
    - ◆ Triggered by rising edge
    - ◆ Triggered by rising edge or falling edge
- Supports PSIO PIN for pin state control
  - Supports 8 check points to connect with slots in each pin
  - Supports 8 check point actions in each check point.
  - Supports 7 kinds of check point action to setting
    - ◆ Output high
    - ◆ Output low
    - ◆ Output data
    - ◆ Output toggle
    - ◆ Input data
    - ◆ Input status
    - ◆ Input status update
  - Supports 4 I/O modes, input, output, open-drain, and quasi
  - Supports switch I/O mode in different check points
- Supports 4 kinds of Interrupt trigger conditions
  - Two sets of configurable slot interrupt controllers
  - Mismatch interrupt when PSIO is enabled with PDMA

- Transfer Error interrupt
- Slot controller counting done interrupt
- Supports PDMA function

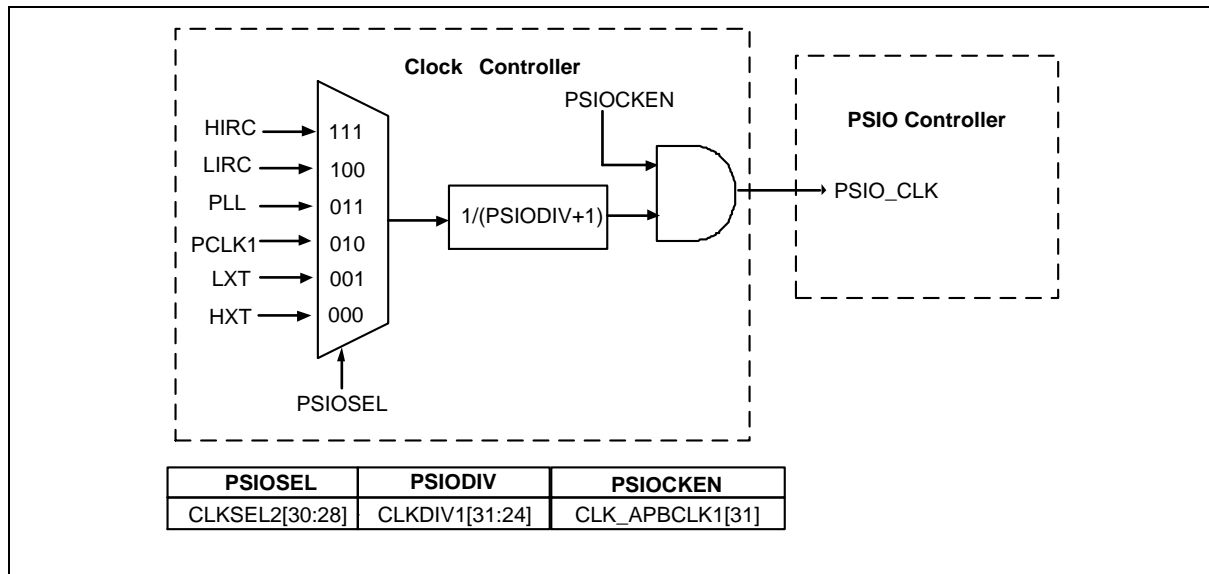

Figure 6.22-1 PSIO Clock Control Diagram (8-bit Pre-scale Counter in Clock Controller)

## 6.23 External Bus Interface (EBI)

### 6.23.1 Overview

This chip is equipped with an external bus interface (EBI) for external device use. To save the connections between an external device and a chip, EBI is operating at address bus and data bus multiplex mode. The EBI supports three chip selects that can connect three external devices with different timing setting requirements.

### 6.23.2 Features

- Supports up to three memory banks
- Supports dedicated external chip select pin with polarity control for each bank
- Supports accessible space up to 1 Mbytes for each bank, actually external addressable space is dependent on package pin out
- Supports 8-/16-bit data width
- Supports byte write in 16-bit data width mode
- Supports Address/Data multiplexed Mode
- Supports Timing parameters individual adjustment for each memory block
- Supports LCD interface i80 mode
- Supports PDMA mode
- Supports variable external bus base clock (MCLK) which based on HCLK
- Supports configurable idle cycle for different access condition: Idle of Write command finish (W2X) and Idle of Read-to-Read (R2R)

## 6.24 USB 1.1 Device Controller (USB D)

### 6.24.1 Overview

There is one set of USB 2.0 full-speed device controller and transceiver in this device. It is compliant with USB 2.0 full-speed device specification and supports control/bulk/interrupt/isochronous transfer types.

In this device controller, there are two main interfaces: the APB bus and USB bus which comes from the USB PHY transceiver. For the APB bus, the CPU can program control registers through it. There are 1 Kbytes internal SRAM as data buffer in this controller. For IN or OUT transfer, it is necessary to write data to SRAM or read data from SRAM through the APB interface or SIE. User needs to set the effective starting address of SRAM for each endpoint buffer through buffer segmentation register (USB D\_BUFSEGx).

There are 12 endpoints in this controller. Each of the endpoint can be configured as IN or OUT endpoint. All the operations including Control, Bulk, Interrupt and Isochronous transfer are implemented in this block. The block of "Endpoint Control" is also used to manage the data sequential synchronization, endpoint states, current start address, transaction status, and data buffer status for each endpoint.

There are five different interrupt events in this controller. They are the no-event-wake-up, device plug-in or plug-out event, USB events, like IN ACK, OUT ACK etc, and BUS events, like suspend and resume, etc. Any event will cause an interrupt, and users just need to check the related event flags in interrupt event status register (USB D\_INTSTS) to acknowledge what kind of interrupt occurring, and then check the related USB Endpoint Status Register (USB D\_EPSTS0 and USB D\_EPSTS1) to acknowledge what kind of event occurring in this endpoint.

A software-disconnect function is also supported for this USB controller. It is used to simulate the disconnection of this device from the host. If user enables SE0 bit (USB D\_SE0), the USB controller will force the output of USB\_D+ and USB\_D- to level low and its function is disabled. After disable the SE0 bit, host will enumerate the USB device again.

For more information on the Universal Serial Bus, please refer to *Universal Serial Bus Specification Revision 1.1*.

### 6.24.2 Features

- Compliant with USB 2.0 Full-Speed specification
- Provides 1 interrupt vector with 5 different interrupt events (SOF, NEVWK, VBUSDET, USB and BUS)
- Supports Control/Bulk/Interrupt/Isochronous transfer type
- Supports suspend function when no bus activity existing for 3 ms
- Supports 12 endpoints for configurable Control/Bulk/Interrupt/Isochronous transfer types and maximum 1 Kbytes buffer size
- Provides remote wake-up capability

## 6.25 CRC Controller (CRC)

### 6.25.1 Overview

The Cyclic Redundancy Check (CRC) generator can perform CRC calculation with four common polynomials CRC-CCITT, CRC-8, CRC-16, and CRC-32 settings.

### 6.25.2 Features

- Supports four common polynomials CRC-CCITT, CRC-8, CRC-16, and CRC-32
  - CRC-CCITT:  $X^{16} + X^{12} + X^5 + 1$
  - CRC-8:  $X^8 + X^2 + X + 1$
  - CRC-16:  $X^{16} + X^{15} + X^2 + 1$
  - CRC-32:  $X^{32} + X^{26} + X^{23} + X^{22} + X^{16} + X^{12} + X^{11} + X^{10} + X^8 + X^7 + X^5 + X^4 + X^2 + X + 1$
- Programmable seed value
- Supports programmable order reverse setting for input data and CRC checksum
- Supports programmable 1's complement setting for input data and CRC checksum
- Supports 8/16/32-bit of data width
  - 8-bit write mode: 1-AHB clock cycle operation
  - 16-bit write mode: 2-AHB clock cycle operation
  - 32-bit write mode: 4-AHB clock cycle operation
- Supports using PDMA to write data to perform CRC operation

## 6.26 Enhanced 12-bit Analog-to-Digital Converter (EADC)

### 6.26.1 Overview

The chip contains one 12-bit successive approximation analog-to-digital converter (SAR ADC converter) with 16 external input channels and 3 internal channels. The ADC converter can be started by software trigger, PWM0/1 triggers, BPWM0/1 triggers, Timer0~3 overflow pulse triggers, ADINT0, ADINT1 interrupt EOC (End of conversion) pulse trigger and external pin (EADC0\_ST) input signal.

### 6.26.2 Features

- Analog input voltage range: 0~ $V_{REF}$  (Max to  $AV_{DD}$ )
- Reference voltage from  $V_{REF}$  pin or  $AV_{DD}$
- 12-bit resolution and 10-bit accuracy is guaranteed
- Up to 16 single-end analog external input channels
- 3 internal channels, they are band-gap voltage ( $V_{BG}$ ), temperature sensor ( $V_{TEMP}$ ), and Battery power ( $V_{BAT/4}$ )
- Four EADC interrupts (ADINT0~3) with individual interrupt vector addresses
- Maximum EADC clock frequency is 16 MHz
- Up to 730 kSPS conversion rate
- Configurable EADC internal sampling time.
- Up to 19 sample modules:
  - Each of sample is configurable for EADC converter channel EADC\_CH0~15 and trigger source
  - Sample module 16~18 is fixed for EADC channel 16, 17, 18 input sources as band-gap voltage, temperature sensor, and battery power ( $V_{BAT/4}$ )
  - Configurable sampling time for each sample module
  - Support left-adjusted result
  - 12-bit resolution for conversion result and 16-bit resolution for accumulated conversion result
  - Conversion results are held in 19 data registers with valid and overrun indicators
  - Averaging ( $2^n$  times,  $n=0\sim 8$ ) to support up to 12-bit result and over-sampling, or called Accumulation, ( $2^n$  times,  $n=0\sim 8$ ) to support up to 16-bit result
- An ADC conversion can be started by:
  - Write 1 to SWTRGn (EADC\_SWTRG[n],  $n = 0\sim 18$ )
  - External pin EADC0\_ST
  - Timer0~3 overflow pulse triggers
  - ADINT0 and ADINT1 interrupt EOC (End of conversion) pulse triggers
  - PWM0/1 triggers
  - BPWM0/1 triggers
- Supports configurable PDMA transfer
- Auto turn on/off EADC power at power off or operation mode with wait state(10us stable time)

- Supports digital comparator to monitor conversion result and user can select whether to generate an interrupt when conversion result matches the compare register setting
- Internal reference voltage source: 1.536V, 2.048V, 2.560V, 3.072V, 4.096V and  $V_{REF}$  pin
- Supports offset cancellation

## 6.27 Digital to Analog Converter (DAC)

### 6.27.1 Overview

The DAC module is a 12-bit, voltage output digital-to-analog converter. It can be configured to 12-or 8-bit output mode and can be used in conjunction with the PDMA controller. The DAC integrates a voltage output buffer that can be used to reduce output impedance and drive external loads directly without having to add an external operational amplifier.

### 6.27.2 Features

- Analog output voltage range: 0~AV<sub>DD</sub>.
- Supports 12-or 8-bit output mode.
- Rail to rail settle time 6us.
- Supports up to one 12-bit 1 MSPS voltage type DAC.
- Reference voltage from internal reference voltage (INT\_VREF), V<sub>REF</sub> pin.
- DAC maximum conversion updating rate 1 MSPS.
- Supports voltage output buffer mode and bypass voltage output buffer mode.
- Supports software and hardware trigger, including Timer0~3 and external trigger pin to start DAC conversion.
- Supports PDMA mode.

## 6.28 Analog Comparator Controller (ACMP)

### 6.28.1 Overview

The chip provides two comparators. The comparator output is logic 1 when positive input is greater than negative input; otherwise, the output is 0. Each comparator can be configured to generate an interrupt when the comparator output value changes.

### 6.28.2 Features

- Analog input voltage range: 0 ~ AV<sub>DD</sub>
- Up to two rail-to-rail analog comparators
- Supports hysteresis function
  - Supports programmable hysteresis window: 0mV, 10mV, 20mV and 30mV
- Supports wake-up function
- Supports programmable propagation speed and low power consumption
- Selectable input sources of positive input and negative input
- ACMP0 supports:
  - 4 multiplexed I/O pins at positive sources:
    - ◆ ACMP0\_P0, ACMP0\_P1, ACMP0\_P2, or ACMP0\_P3
  - 4 negative sources:
    - ◆ ACMP0\_N
    - ◆ Comparator Reference Voltage (CRV)
    - ◆ Internal band-gap voltage (V<sub>BG</sub>)
    - ◆ DAC0 output (DAC0\_OUT)
- ACMP1 supports:
  - 4 multiplexed I/O pins at positive sources:
    - ◆ ACMP1\_P0, ACMP1\_P1, ACMP1\_P2, or ACMP1\_P3
  - 4 negative sources:
    - ◆ ACMP1\_N
    - ◆ Comparator Reference Voltage (CRV)
    - ◆ Internal band-gap voltage (V<sub>BG</sub>)
    - ◆ DAC0 output (DAC0\_OUT)
- Shares one ACMP interrupt vector for all comparators
- Interrupts generated when compare results change (Interrupt event condition is programmable)
- Supports triggers for break events and cycle-by-cycle control for PWM
- Supports window compare mode and window latch mode

## 6.29 OP Amplifier (OPA)

### 6.29.1 Overview

This chip is equipped with one operational amplifier. The OP amplifier outputs is connected to ADC channel for measurement requirement. The OP amplifier circuit can also be used in the application of Programmable Gain Amplifier (PGA).

### 6.29.2 Features

- Analog input voltage range: 0~AV<sub>DD</sub>.
- Supports up to 1 operational amplifier
- Supports to use schmitt trigger buffer output for simple comparator function.
- Supports schmitt trigger buffer output interrupts.

### 6.30 Peripherals Interconnection

#### 6.30.1 Overview

Some peripherals have interconnections which allow autonomous communication or synchronous action between peripherals without needing to involve the CPU. Peripherals interact without CPU saves CPU resources, reduces power consumption, operates with no software latency and fast responds.

#### 6.30.2 Peripherals Interconnect Matrix table

Source	Destination							
	ACMP	BPWM	DAC	EADC	HIRC TRIM	PWM	Timer	UART
ACMP	-	-	-	-	-	<a href="#">14</a>	<a href="#">17</a>	-
BandGap	<a href="#">1</a>	-	-	-	-	-	-	-
BOD	-	-	-	-	-	<a href="#">14</a>	-	-
BPWM	-	<a href="#">3</a>	-	<a href="#">11</a>	-	<a href="#">15</a>	-	-
Clock Fail	-	-	-	-	-	<a href="#">14</a>	-	-
CRV	<a href="#">1</a>	-	-	-	-	-	-	-
CPU Lockup	-	-	-	-	-	<a href="#">14</a>	-	-
DAC	<a href="#">1</a>	-	-	-	-	-	-	-
Internal Module	-	-	<a href="#">5</a>	<a href="#">8, 9</a>	-	-	-	-
LIRC	-	-	-	-	-	-	-	-
External Pin	<a href="#">1, 2</a>	-	<a href="#">5, 6</a>	<a href="#">8, 9, 10</a>	-	<a href="#">14</a>	-	-
LIRC	-	-	-	-	-	-	<a href="#">17</a>	-
LXT	-	-	-	-	<a href="#">13</a>	-	-	-
PWM	-	<a href="#">3</a>	-	<a href="#">11</a>	-	<a href="#">14, 15</a>	-	<a href="#">19</a>
Timer	-	<a href="#">4</a>	<a href="#">7</a>	<a href="#">12</a>	-	<a href="#">16</a>	-	-
UART	-	-	-	-	-	-	-	<a href="#">19</a>
USB 1.1 Device	-	-	-	-	<a href="#">13</a>	-	<a href="#">18</a>	-

Table 6.30-1 Peripherals Interconnect Matrix Table

## 7 APPLICATION CIRCUIT

### 7.1 Power Supply Scheme

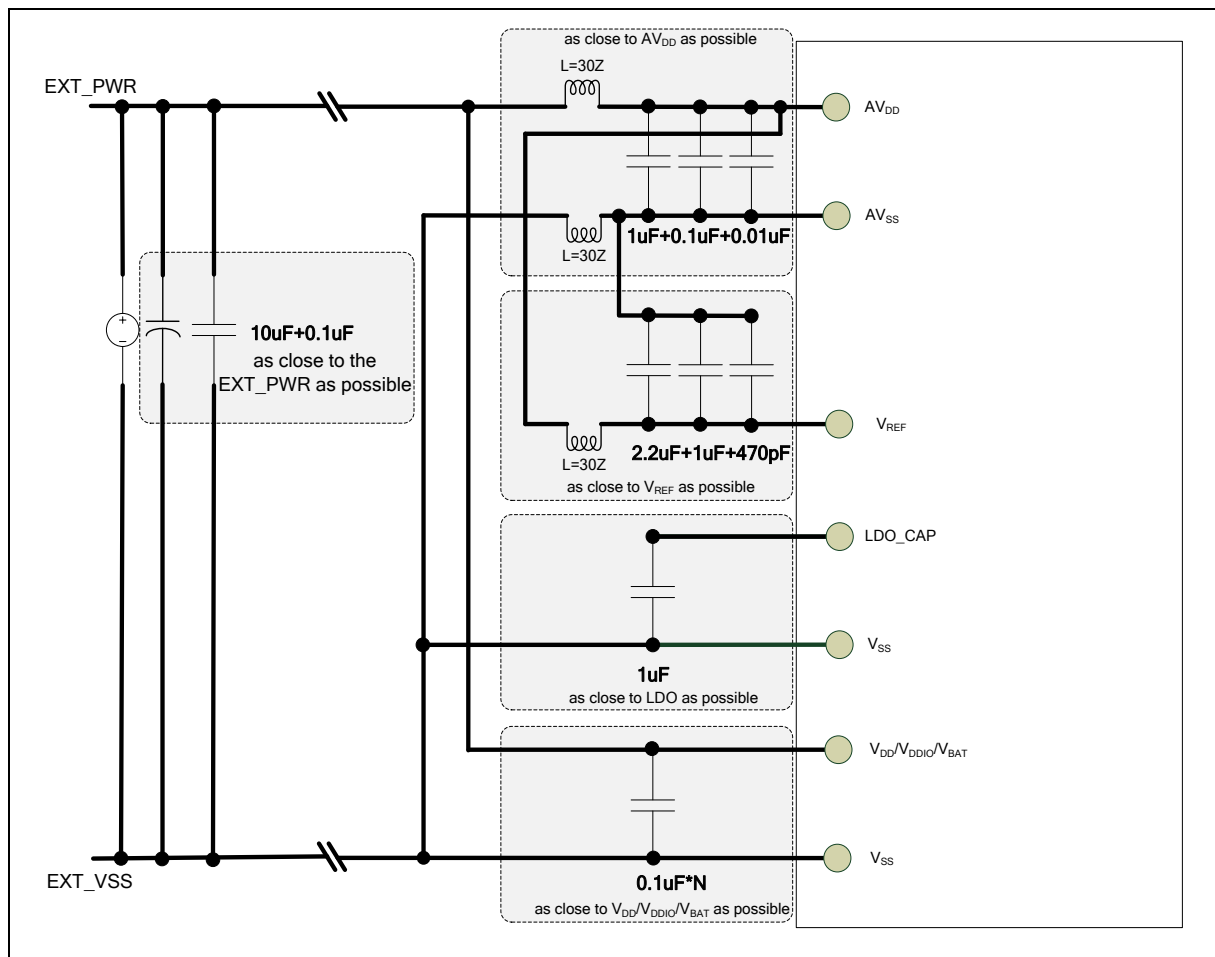

7.2 Peripheral Application Scheme

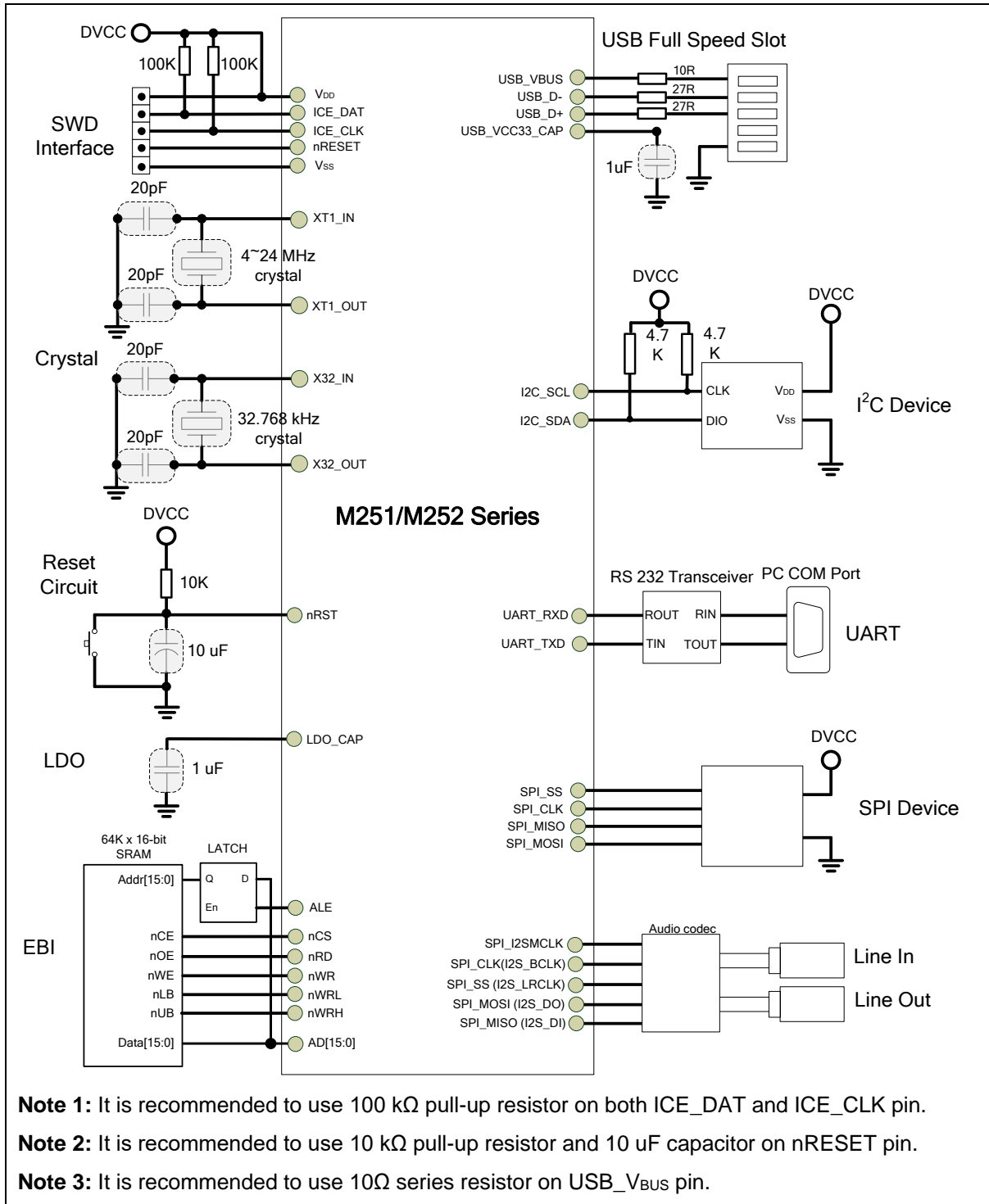

## 8 ELECTRICAL CHARACTERISTICS

### 8.1 Absolute Maximum Ratings

Stresses above the absolute maximum ratings may cause permanent damage to the device. The limiting values are stress ratings only and cannot be used to functional operation of the device. Exposure to the absolute maximum ratings may affect device reliability and proper operation is not guaranteed.

#### 8.1.1 Voltage Characteristics

Symbol	Description	Min	Max	Unit
$V_{DD}-V_{SS}^{[*1]}$	DC power supply	-0.3	6.5	V
$V_{DDIO}-V_{SS}^{[*1]}$	$V_{DDIO}$ Power Supply	-0.3	6.5	V
$V_{BAT}-V_{SS}^{[*1]}$	$V_{BAT}$ Power Supply	-0.3	6.5	V
$\Delta V_{DD}$	Variations between different $V_{DD}$ power pins	-	50	mV
$ V_{DD} - AV_{DD} $	Allowed voltage difference for $V_{DD}$ and $AV_{DD}$	-	50	mV
$\Delta V_{SS}$	Variations between different ground pins	-	50	mV
$ V_{SS} - AV_{SS} $	Allowed voltage difference for $V_{SS}$ and $AV_{SS}$	-	50	mV
$V_{IN}$	Input voltage on any other pin <sup>[*2]</sup>	$V_{SS}-0.3$	6.5	V

**Note:**

- All main power ( $V_{DD}$ ,  $V_{DDIO}$ ,  $V_{BAT}$ ,  $AV_{DD}$ ) and ground ( $V_{SS}$ ,  $AV_{SS}$ ) pins must be connected to the external power supply.
- Refer to Table 8.1-2 for the values of the maximum allowed injected current.

Table 8.1-1 Voltage Characteristics

8.1.2 Current Characteristics

Symbol	Description	Min	Max	Unit
$\Sigma I_{DD}^{[1]}$	Maximum current into $V_{DD}$	-	200	mA
$I_{DDIO} / I_{BAT}$	Maximum current into $V_{DDIO} / I_{BAT}$	-	100 / 100	
$\Sigma I_{SS}$	Maximum current out of $V_{SS}$	-	100	
$I_{IO}$	Maximum current sunk by a I/O Pin	-	20	
	Maximum current sourced by a I/O Pin	-	20	
	Maximum current sunk by total I/O Pins <sup>[2]</sup>	-	100	
	Maximum current sourced by total I/O Pins <sup>[2]</sup>	-	100	
$I_{INJ(PIN)}^{[3]}$	Maximum injected current by a I/O Pin	-	±5	
$\Sigma I_{INJ(PIN)}^{[3]}$	Maximum injected current by total I/O Pins	-	±25	

**Note:**

- Maximum allowable current is a function of device maximum power dissipation.
- This current consumption must be correctly distributed over all I/Os and control pins. The total output current must not be sunk/sourced between two consecutive power supply pins.
- A positive injection is caused by  $V_{IN} > A_{VDD}$  and a negative injection is caused by  $V_{IN} < V_{SS}$ .  $I_{INJ(PIN)}$  must never be exceeded. It is recommended to connect an overvoltage protection diode between the analog input pin and the voltage supply pin.

Table 8.1-2 Current Characteristics

### 8.1.3 Thermal Characteristics

The average junction temperature can be calculated by using the following equation:

$$T_J = T_A + (P_D \times \theta_{JA})$$

- $T_A$  = ambient temperature (°C)
- $\theta_{JA}$  = thermal resistance junction-ambient (°C/Watt)
- $P_D$  = sum of internal and I/O power dissipation

Symbol	Description	Min	Typ	Max	Unit
$T_A$	Operating ambient temperature	-40	-	105	°C
$T_J$	Operating junction temperature	-40	-	125	
$T_{ST}$	Storage temperature	-65	-	150	
$\theta_{JA}^{(*)}$	Thermal resistance junction-ambient 20-pin TSSOP(4.4x6.5 mm)	-	38	-	°C/Watt
	Thermal resistance junction-ambient 28-pin TSSOP(4.4x9.7 mm)	-	30	-	°C/Watt
	Thermal resistance junction-ambient 33-pin QFN(5x5 mm)	-	39.6	-	°C/Watt
	Thermal resistance junction-ambient 48-pin LQFP(7x7 mm)	-	60	-	°C/Watt
	Thermal resistance junction-ambient 64-pin LQFP(7x7 mm)	-	58	-	°C/Watt
	Thermal resistance junction-ambient 128-pin LQFP(14x14 mm)	-	38.5	-	°C/Watt
<b>Note:</b>					
1. Determined according to JESD51-2 Integrated Circuits Thermal Test Method Environment Conditions					

Table 8.1-3 Thermal Characteristics

**8.1.4 EMC Characteristics**

**8.1.4.1 Electrostatic discharge (ESD)**

For the Nuvoton MCU products, there are ESD protection circuits which built into chips to avoid any damage that can be caused by typical levels of ESD.

**8.1.4.2 Static latchup**

Two complementary static tests are required on six parts to assess the latchup performance:

- A supply overvoltage is applied to each power supply pin
- A current injection is applied to each input, output and configurable I/O pin

**8.1.4.3 Electrical fast transients (EFT)**

In some application circuit compoment will produce fast and narrow high-frequency trasnients bursts of narrow high-frequency transients on the power distribution system..

- Inductive loads:
  - Relays, switch contactors
  - Heavy-duty motors when de-energized etc.

The fast transient immunity requirements for electronic products are defined in IEC 61000-4-4 by International ElectrotechnicalCommission (IEC).

Symbol	Description	Min	Typ	Max	Unit
V <sub>HBM</sub> <sup>[1]</sup>	Electrostatic discharge, human body mode	-6000	-	+6000	V
V <sub>CDM</sub> <sup>[2]</sup>	Electrostatic discharge, charge device model	-1000	-	+1000	
LU <sup>[3]</sup>	Pin current for latch-up <sup>[3]</sup>	-150 Class I	-	+150 Class I	mA
V <sub>EFT</sub> <sup>[4][5]</sup>	Fast transient voltage burst	-4.4	-	+4.4	kV
<p><b>Note:</b></p> <ol style="list-style-type: none"> <li>1. Determined according to ANSI/ESDA/JEDEC JS-001 Standard, Electrostatic Discharge Sensitivity Testing – Human Body Model (HBM) – Component Level</li> <li>2. Determined according to ANSI/ESDA/JEDEC JS-002 standard for Electrostatic Discharge Sensitivity (ESD) Testing – Charged Device Model (CDM) – Component Level.</li> <li>3. Determined according to JEDEC EIA/JESD78 standard.</li> <li>4. Determined according to IEC 61000-4-4 Electrical fast transient/burst immunity test.</li> <li>5. The performace cretia class is 4A.</li> </ol>					

Table 8.1-4 EMC Characteristics for M251xC/M251xD/M252xC/M252xD

Symbol	Description	Min	Typ	Max	Unit
V <sub>HBM</sub> <sup>[1]</sup>	Electrostatic discharge, human body mode for M251xG and M252xG	-6000	-	+6000	V
	Electrostatic discharge, human body mode for M251xE and M252xE	-5000	-	+5000	
V <sub>CDM</sub> <sup>[2]</sup>	Electrostatic discharge, charge device model	-500	-	+500	
LU <sup>[3]</sup>	Pin current for latch-up <sup>[3]</sup>	-150 Class I	-	+150 Class I	mA
V <sub>EFT</sub> <sup>[4][5]</sup>	Fast transient voltage burst	-4.4	-	+4.4	kV
<b>Note:</b> <ol style="list-style-type: none"> <li>1. Determined according to ANSI/ESDA/JEDEC JS-001 Standard, Electrostatic Discharge Sensitivity Testing – Human Body Model (HBM) – Component Level</li> <li>2. Determined according to ANSI/ESDA/JEDEC JS-002 standard for Electrostatic Discharge Sensitivity (ESD) Testing – Charged Device Model (CDM) – Component Level.</li> <li>3. Determined according to JEDEC EIA/JESD78 standard.</li> <li>4. Determined according to IEC 61000-4-4 Electrical fast transient/burst immunity test.</li> <li>5. The performance criteria class is 4A.</li> </ol>					

Table 8.1-5 EMC Characteristics for M251xE/M251xG/M252xE/M252xG

**8.1.5 Package Moisture Sensitivity (MSL)**

The MSL rating of an IC determines its floor life before the board mounting once its dry bag has been opened. All Nuvoton surface mount chips have a moisture level classification. The information is also displayed on the bag packing.

Pacakge	MSL
20-pin TSSOP(4.4x6.5 mm) [1]	MSL 3
28-pin TSSOP(4.4x9.7 mm) [1]	MSL 3
33-pin QFN(5x5 mm) [1]	MSL 3
48-pin LQFP(7x7 mm) [1]	MSL 3
64-pin LQFP(7x7 mm) [1]	MSL 3
128-pin LQFP(14x14 mm) [1]	MSL 3
<b>Note:</b>	
1. Determined according to IPC/JEDEC J-STD-020	

Table 8.1-6 Package Moisture Sensitivity(MSL)

8.1.6 Soldering Profile

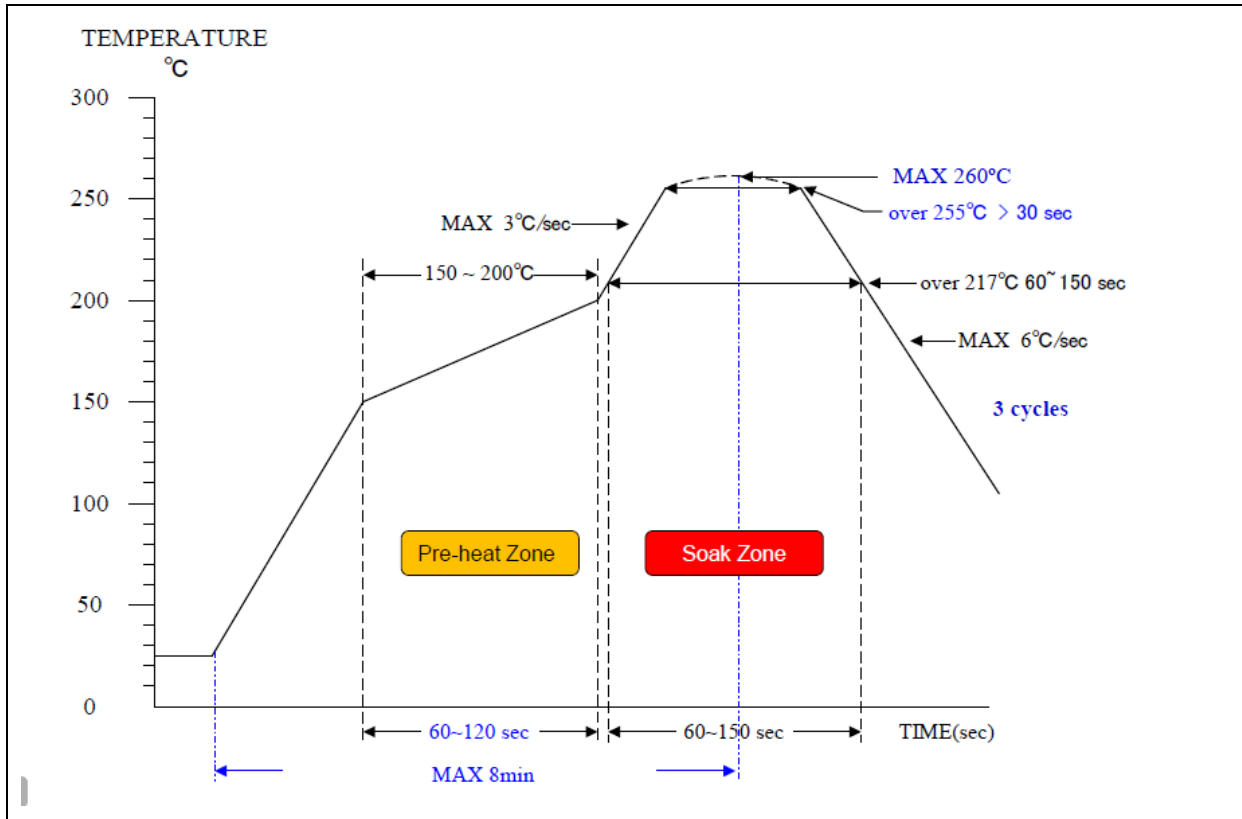

Figure 8.1-1 Soldering profile from J-STD-020C

Profile Feature	Pb Free Package
Average ramp-up rate (217°C to peak)	3°C/sec. max
Preheat temperature 150°C ~200°C	60 sec. to 120 sec.
Temperature maintained above 217°C	60 sec. to 150 sec.
Time with 5°C of actual peak temperature	> 30 sec.
Peak temperature range	260°C
Ramp-down rate	6°C/sec ax.
Time 25°C to peak temperature	8 min. max
<b>Note:</b> 1. Determined according to J-STD-020C	

Table 8.1-7 Soldering Profile

### 8.2 General Operating Conditions

( $V_{DD}-V_{SS} = 1.75 \sim 5.5V$ ,  $T_A = 25^\circ C$ ,  $HCLK = 48 \text{ MHz}$  unless otherwise specified.)

Symbol	Parameter	Min	Typ	Max	Unit	Test Conditions
$T_A$	Temperature	-40	-	105	$^\circ C$	
$f_{HCLK}$	Internal AHB clock frequency	-	-	48	MHz	
$V_{DD}$	Operation voltage	1.75	-	5.5	V	
$V_{DDIO}$	$V_{DDIO}$ Operation voltage	1.65	-	5.5		
$V_{BAT}$	$V_{BAT}$ Operation voltage	1.75	-	5.5		
$AV_{DD}^{[*1]}$	Analog operation voltage	$V_{DD}$				
$V_{REF}$	Analog reference voltage	1.75	-	$AV_{DD}$		
$V_{LDO}$	LDO output voltage	-	1.5	-		
$V_{BG}$	Band-gap voltage	795	815	840		mV
$C_{LDO}^{[*2]}$	LDO output capacitor on each pin	1			$\mu F$	
$R_{ESR}^{[*3]}$	ESR of $C_{LDO}$ output capacitor	-	-	0.5	$\Omega$	
$I_{RUSH}^{[*3]}$	InRush current on voltage regulator power-on (POR or wakeup from Standby)	-	60	150	mA	
$E_{RUSH}^{[*3]}$	InRush energy on voltage regulator power-on (POR or wakeup from Standby)	-	0.9	-	$\mu C$	$V_{DD} = 1.8 \text{ V}$ , $T_A = 105^\circ C$ , $I_{RUSH} = 60 \text{ mA}$ for $15 \mu s$
<b>Note:</b>						
<ol style="list-style-type: none"> <li>1. It is recommended to power <math>V_{DD}</math> and <math>AV_{DD}</math> from the same source. A maximum difference of 0.3 V between <math>V_{DD}</math> and <math>AV_{DD}</math> can be tolerated during power-on and power-off operation .</li> <li>2. To ensure stability, an external 1 <math>\mu F</math> output capacitor, <math>C_{LDO}</math> must be connected between the LDO_CAP pin and the closest GND pin of the device. Solid tantalum and multilayer ceramic capacitors are suitable as output capacitor. Additional 100 nF bypass capacitor between LDO_CAP pin and the closest GND pin of the device helps decrease output noise and improves the load transient response.</li> <li>3. Guaranteed by design, not tested in production</li> </ol>						

Table 8.2-1 General Operating Conditions

### 8.3 DC Electrical Characteristics

#### 8.3.1 Supply Current Characteristics for M251xC/M251xD/M252xC/M252xD

The current consumption is a combination of internal and external parameters and factors such as operating frequencies, device software configuration, I/O pin loading, I/O pin switching rate, program location in memory and so on. The current consumption is measured as described in below condition and table to inform test characterization result.

- All GPIO pins are in push pull mode and output high.
- The maximum values are obtained for  $V_{DD} = 5.5\text{ V}$  and maximum ambient temperature ( $T_A$ ), and the typical values for  $T_A = 25\text{ °C}$  and  $V_{DD} = 1.75 \sim 5.5\text{ V}$  unless otherwise specified.
- $V_{DD} = AV_{DD} = V_{DDIO}$
- When the peripherals are enabled HCLK is the system clock,  $f_{PCLK0, 1} = f_{HCLK}$ .
- Program run CoreMark® code in Flash.

Symbol	Conditions	$F_{HCLK}$	Typ <sup>[*1]</sup>	Max <sup>[*1][*2]</sup>				Unit
			$T_A = 25\text{ °C}$	$T_A = 25\text{ °C}$	$T_A = 85\text{ °C}$	$T_A = 105\text{ °C}$		
$I_{DD\_RUN}$	Normal run mode with PL0 (PLSEL = 00), executed from Flash, all peripherals disable. HCLK is set as HIRC, PLL or HXT clock.	48 MHz	5.4	6.05	6.25	6.45	mA	
		32 MHz	4.1	4.6	4.8	5.1		
		24 MHz	3.2	3.65	3.85	4.1		
		12 MHz	2.0	2.3	2.5	2.8		
	Normal run mode with PL0 (PLSEL = 00), executed from Flash, all peripherals disable. HCLK is set as MIRC clock.	4 MHz	0.74	0.95	1.15	1.35		
		2 MHz	0.55	0.75	0.9	1.1		
		1 MHz	0.45	0.6	0.80	1.0		
	Normal run mode with PL3 (PLSEL = 11), executed from Flash, all peripherals disable. HCLK is set as LIRC or LXT clock..	38.4 kHz	0.01	0.02	0.06	0.16		
		32.768 kHz	0.01	0.02	0.06	0.16		
	Normal run mode with PL0 (PLSEL = 00), executed from Flash, all peripherals enable. HCLK is set as HIRC, PLL or HXT clock.	48 MHz	15	16.6	16.8	17		
		32 MHz	10	11.5	11.8	12		
		24 MHz	8.0	9.0	9.3	9.5		
		12 MHz	4.5	5.05	5.3	5.5		
	Normal run mode with PL0 (PLSEL = 00), executed from Flash, all peripherals enable. HCLK is set as MIRC clock.	4 MHz	1.4	1.65	1.85	2.1		
		2 MHz	0.95	1.15	1.35	1.6		
		1 MHz	0.65	0.85	1.1	1.3		
Normal run mode with PL3 (PLSEL = 11), executed from Flash, all peripherals enable. HCLK is set as LIRC or LXT clock..	38.4 kHz	0.02	0.03	0.06	0.17			
	32.768 kHz	0.02	0.03	0.06	0.17			

**Note:**

1. When analog peripheral blocks such as USB, ADC, ACMP, PLL, HIRC, MIRC, LIRC, HXT and LXT are ON, an additional power consumption should be considered.
2. Based on characterization, not tested in production unless otherwise specified.

Table 8.3-1 Current Consumption in Normal Run Mode

Symbol	Conditions	F <sub>HCLK</sub>	Typ <sup>[*1]</sup>	Max <sup>[*1][*2]</sup>				Unit
			T <sub>A</sub> = 25 °C	T <sub>A</sub> = 25 °C	T <sub>A</sub> = 85 °C	T <sub>A</sub> = 105 °C		
I <sub>DD_IDLE</sub>	Idle mode with PL0 (PLSEL = 00), all peripherals disable. HCLK is set as HIRC, PLL or HXT clock.	48 MHz	2.25	2.6	2.8	3.0	mA	
		32 MHz	2.05	2.4	2.6	2.8		
		24 MHz	1.6	1.9	2.1	2.3		
		12 MHz	1.2	1.45	1.65	1.85		
	Idle mode with PL0 (PLSEL = 00), all peripherals disable. HCLK is set as MIRC clock.	4 MHz	0.47	0.62	0.8	1.0		
		2 MHz	0.42	0.57	0.77	0.97		
		1 MHz	0.39	0.53	0.73	0.93		
	Idle mode with PL3 (PLSEL = 11), all peripherals disable HCLK is set as LIRC or LXT clock.	38.4 kHz	0.01	0.02	0.06	0.16		
		32.768 kHz	0.01	0.02	0.06	0.16		
	Idle mode with PL0 (PLSEL = 00), all peripherals disable. HCLK is set as HIRC, PLL or HXT clock.	48 MHz	12	13.3	13.4	13.7		
		32 MHz	8.1	9.1	9.3	9.5		
		24 MHz	6.6	7.4	7.6	7.8		
		12 MHz	3.9	4.4	4.6	4.8		
	Idle mode with PL0 (PLSEL = 00), all peripherals disable. HCLK is set as MIRC clock.	4 MHz	1.25	1.5	1.7	1.9		
		2 MHz	0.8	1.0	1.2	1.4		
		1 MHz	0.58	0.74	0.95	1.15		
Idle mode with PL3 (PLSEL = 11), all peripherals enable HCLK is set as LIRC or LXT clock.	38.4 kHz	0.02	0.03	0.06	0.17			
	32.768 kHz	0.02	0.03	0.06	0.17			

**Note:**

1. When analog peripheral blocks such as USB, ADC, ACMP, PLL, HIRC, MIRC, LIRC, HXT and LXT are ON, an additional power consumption should be considered.
2. Based on characterization, not tested in production unless otherwise specified.

Table 8.3-2 Current consumption in Idle Mode

Symbol	Test Conditions	LXT <sup>[1]</sup> 32.768 kHz	LIRC 38.4 kHz	Typ <sup>[2]</sup> T <sub>A</sub> = 25 °C	Max <sup>[3][4]</sup>				Unit
					T <sub>A</sub> = 25 °C	T <sub>A</sub> = 85 °C	T <sub>A</sub> = 105 °C	T <sub>A</sub> = 105 °C	
I <sub>DD_DPD</sub>	Deep Power-down mode, all peripherals disable	-	-	1.45	3.5	15.5	76	μA	
	Deep Power-down mode, RTC enable and run	V	-	2.0	3.95	16	78		
I <sub>DD_PD</sub>	Power-down mode, all peripherals disable	-	-	1.7	3.7	23.5	128	μA	
	Power-down mode, RTC enable and run	V	-	2.5	4.55	25	129		
	Power-down mode, WDT/Timer enable and run	-	V	3.65	5.65	26	130		
	Power-down mode, WDT/Timer/UART/RTC enable and run, WDT use LIRC, UART/Timer/RTC use LXT	V	V	4.3	6.2	26.5	131		
I <sub>DD_FWPD</sub>	Fast wake up Power-down mode, all peripherals disable	-	-	100	140	171	292	μA	
	Fast wake up Power-down mode, RTC enable and run	V	-	101	141	173	293		
	Fast wake up Power-down mode, WDT/Timer enable and run	-	V	102	142	174	295		
	Fast wake up Power-down mode, WDT/Timer/UART/RTC enable and run, WDT use LIRC, UART/Timer/RTC use LXT	V	V	103	143	175	296		
<p><b>Note:</b></p> <ol style="list-style-type: none"> <li>Crystal used: AURUM XF66RU000032C0 with a C<sub>L</sub> of 20 pF for L1 gain level</li> <li>V<sub>DD</sub> = AV<sub>DD</sub> = 3.3V, LVR17 enabled, POR disabled and BOD disabled.</li> <li>Based on characterization, not tested in production unless otherwise specified.</li> <li>When analog peripheral blocks such as USB, ADC and ACMP are ON, an additional power consumption should be considered.</li> </ol>									

Table 8.3-3 Chip Current Consumption in Power-down Mode

### 8.3.2 Supply Current Characteristics for M251xE/M251xG/M252xE/M252xG

The current consumption is a combination of internal and external parameters and factors such as operating frequencies, device software configuration, I/O pin loading, I/O pin switching rate, program location in memory and so on. The current consumption is measured as described in below condition and table to inform test characterization result.

- All GPIO pins are in push pull mode and output high.
- The maximum values are obtained for  $V_{DD} = 5.5\text{ V}$  and maximum ambient temperature ( $T_A$ ), and the typical values for  $T_A = 25\text{ }^\circ\text{C}$  and  $V_{DD} = 1.75 \sim 5.5\text{ V}$  unless otherwise specified.
- $V_{DD} = AV_{DD} = V_{DDIO} = V_{BAT}$
- When the peripherals are enabled HCLK is the system clock,  $f_{PCLK0,1} = f_{HCLK}$ .
- Program runs CoreMark® code in Flash.

Symbol	Conditions	F <sub>HCLK</sub>	Typ <sup>[*1]</sup>	Max <sup>[*1][*2]</sup>				Unit
			T <sub>A</sub> = 25 °C	T <sub>A</sub> = 25 °C	T <sub>A</sub> = 85 °C	T <sub>A</sub> = 105 °C		
I <sub>DD_RUN</sub>	Normal run mode with PL0 (PLSEL = 00), executed from Flash, all peripherals disable. HCLK is set as HIRC, PLL or HXT clock.	48 MHz	6.2	6.95	7.15	7.35	mA	
		32 MHz	4.55	5.15	5.35	5.65		
		24 MHz	3.6	4.05	4.25	4.55		
		12 MHz	2.25	2.55	2.75	3.0		
	Normal run mode with PL0 (PLSEL = 00), executed from Flash, all peripherals disable. HCLK is set as MIRC clock.	4 MHz	0.74	0.95	1.15	1.35		
		2 MHz	0.55	0.75	0.9	1.1		
		1 MHz	0.45	0.6	0.80	1.0		
	Normal run mode with PL3 (PLSEL = 11), executed from Flash, all peripherals disable. HCLK is set as LIRC or LXT clock..	38.4 kHz	0.01	0.02	0.06	0.2		
		32.768 kHz	0.01	0.02	0.06	0.2		
	Normal run mode with PL0 (PLSEL = 00), executed from Flash, all peripherals enable. HCLK is set as HIRC, PLL or HXT clock.	48 MHz	17.5	19.5	19.8	20		
		32 MHz	11.5	13	13.3	13.5		
		24 MHz	9.5	10.5	10.8	11		
		12 MHz	5.5	6.1	6.3	6.5		
	Normal run mode with PL0 (PLSEL = 00), executed from Flash, all peripherals enable. HCLK is set as MIRC clock.	4 MHz	1.6	1.85	2.05	2.3		
		2 MHz	1.0	1.25	1.45	1.7		
		1 MHz	0.7	0.95	1.15	1.35		
	Normal run mode with PL3 (PLSEL = 11), executed from Flash, all peripherals enable HCLK is set as LIRC or LXT clock..	38.4 kHz	0.02	0.03	0.07	0.22		
		32.768 kHz	0.02	0.03	0.07	0.22		

**Note:**

1. When analog peripheral blocks such as ADC, OPA, DAC, ACMP, PLL, HIRC, MIRC, LIRC, HXT and LXT are ON, an additional power consumption should be considered.
2. Based on characterization, not tested in production unless otherwise specified.

Table 8.3-4 Current consumption in Normal Run Mode

Symbol	Conditions	F <sub>HCLK</sub>	Typ <sup>[*1]</sup>	Max <sup>[*1][*2]</sup>				Unit
			T <sub>A</sub> = 25 °C	T <sub>A</sub> = 25 °C	T <sub>A</sub> = 85 °C	T <sub>A</sub> = 105 °C		
I <sub>DD_IDLE</sub>	Idle mode with PL0 (PLSEL = 00), all peripherals disable. HCLK is set as HIRC, PLL or HXT clock.	48 MHz	2.4	2.75	2.95	3.05	mA	
		32 MHz	2.25	2.6	2.8	3.0		
		24 MHz	1.7	1.9	2.1	2.3		
		12 MHz	1.25	1.5	1.7	1.9		
	Idle mode with PL0 (PLSEL = 00), all peripherals disable. HCLK is set as MIRC clock.	4 MHz	0.48	0.62	0.8	1.0		
		2 MHz	0.42	0.57	0.77	0.97		
		1 MHz	0.39	0.53	0.73	0.93		
	Idle mode with PL3 (PLSEL = 11), all peripherals disable HCLK is set as LIRC or LXT clock.	38.4 kHz	0.01	0.02	0.06	0.2		
		32.768 kHz	0.01	0.02	0.06	0.2		
	Idle mode with PL0 (PLSEL = 00), all peripherals disable. HCLK is set as HIRC, PLL or HXT clock.	48 MHz	13	14.5	14.7	14.9		
		32 MHz	9.2	10.5	10.7	10.9		
		24 MHz	7.5	8.5	8.7	8.9		
		12 MHz	4.5	5.1	5.3	5.5		
	Idle mode with PL0 (PLSEL = 00), all peripherals disable. HCLK is set as MIRC clock.	4 MHz	1.3	1.55	1.75	1.95		
		2 MHz	0.85	1.1	1.3	1.5		
		1 MHz	0.6	0.8	1.0	1.2		
Idle mode with PL3 (PLSEL = 11), all peripherals enable HCLK is set as LIRC or LXT clock.	38.4 kHz	0.02	0.03	0.07	0.22			
	32.768 kHz	0.02	0.03	0.07	0.22			

**Note:**

1. When analog peripheral blocks such as USB, OPA, DAC, ADC, ACMP, PLL, HIRC, MIRC, LIRC, HXT and LXT are ON, an additional power consumption should be considered.
2. Based on characterization, not tested in production unless otherwise specified.

Table 8.3-5 Current Consumption in Idle Mode

Symbol	Test Conditions	LXT <sup>[1]</sup> 32.768 kHz	LIRC 38.4 kHz	Typ <sup>[2]</sup> T <sub>A</sub> = 25 °C	Max <sup>[3][4]</sup>			Unit
					T <sub>A</sub> = 25 °C	T <sub>A</sub> = 85 °C	T <sub>A</sub> = 105 °C	
I <sub>DD_DPD</sub>	Deep Power-down mode, all peripherals disable	-	-	1.4	3.5	16.5	80	μA
	Deep Power-down mode, RTC enable and run	V	-	1.9	4.3	17.3	82	
I <sub>DD_PD</sub>	Power-down mode, all peripherals disable	-	-	1.8	3.7	30	155	μA
	Power-down mode, RTC enable and run	V	-	2.45	4.7	31	157	
	Power-down mode, WDT/Timer enable and run	-	V	3.9	6	32.5	159	
	Power-down mode, WDT/Timer/UART/RTC enable and run, WDT use LIRC, UART/Timer/RTC use LXT	V	V	4.5	6.9	34	161	
I <sub>DD_FWPD</sub>	Fast wake up Power-down mode, all peripherals disable	-	-	160	260	315	490	μA
	Fast wake up Power-down mode, RTC enable and run	V	-	161	261	316	492	
	Fast wake up Power-down mode, WDT/Timer enable and run	-	V	162	262	318	494	
	Fast wake up Power-down mode, WDT/Timer/UART/RTC enable and run, WDT use LIRC, UART/Timer/RTC use LXT	V	V	163	263	320	496	
<b>Note:</b> <ol style="list-style-type: none"> <li>Crystal used: AURUM XF66RU000032C0 with a C<sub>L</sub> of 20 pF for L3 gain level</li> <li>V<sub>DD</sub> = AV<sub>DD</sub> = V<sub>BAT</sub> = 3.3V, LVR17 enabled, POR disabled and BOD disabled.</li> <li>Based on characterization, not tested in production unless otherwise specified.</li> <li>When analog peripheral blocks such as USB, OPA, DAC, ADC and ACMP are ON, an additional power consumption should be considered.</li> </ol>								

Table 8.3-6 Chip Current Consumption in Power-down Mode

### 8.3.3 On-Chip Peripheral Current Consumption

- The typical values for  $T_A = 25\text{ }^\circ\text{C}$  and  $V_{DD} = AV_{DD} = V_{BAT} = 3.3\text{ V}$  unless otherwise specified.
- All GPIO pins are set as output high of push pull mode without multi-function.
- HCLK is the system clock,  $f_{HCLK} = 48\text{ MHz}$ ,  $f_{PCLK0,1} = f_{HCLK}$ .
- The result value is calculated by measuring the difference of current consumption between all peripherals clocked off and only one peripheral clocked on.
- The peripheral clock selection keeps reset default setting.

Peripheral	$I_{DD}^{[*1]}$	Unit
EADC <sup>[*2]</sup>	0.55	mA
ACMP01 <sup>[*3]</sup>	0.067	
PWM0	0.72	
PWM1	0.75	
BPWM0	0.36	
BPWM1	0.39	
WDT/WWDT	0.05	
QSPI	0.44	
SPI/I2S	0.64	
UART0	0.40	
UART1	0.34	
UART2	0.33	
I2C0	0.058	
I2C1	0.087	
USCI0	0.28	
USCI1	0.26	
USCI2	0.27	
SC0	0.22	
PSIO0	0.75 (4 channels)	
	1.4 (8 channels)	
EBI	0.12	
TMR0	0.28	
TMR1	0.30	
TMR2	0.29	
TMR3	0.26	
RTC	0.046	

USB FS Device <sup>[*4]</sup>	1.03	
CRC	0.045	
PDMA	0.57	
FMC	0.43	
<b>Note:</b> <ol style="list-style-type: none"> <li>1. Guaranteed by characterization results, not tested in production.</li> <li>2. When the ADC is turned on, add an additional power consumption per ADC for the analog part.</li> <li>3. When the ACMP is turned on, add an additional power consumption per ACMP for the analog part.</li> <li>4. When the USB is turned on, add an additional power consumption per USB for the analog part.</li> </ol>		

Table 8.3-7 Peripheral Current Consumption

### 8.3.4 Wakeup Time from Low-Power Modes

The wakeup times given in Table 8.2-1 is measured on a wakeup phase with a 48 MHz HIRC oscillator.

Symbol	Parameter	Typ	Max	Unit
t <sub>WU_IDLE</sub>	Wakeup from IDLE mode	5	6	cycles
t <sub>WU_DPD</sub> <sup>[*1][*2]</sup>	Wakeup from deep Power-down mode	190	250	μS
t <sub>WU_NPD</sub> <sup>[*1][*2]</sup>	Wakeup from normal Power-down mode	19	30	
t <sub>WU_FWPD</sub> <sup>[*1][*2]</sup>	Wakeup from fast wake up Power-down mode	12	15	
<b>Note:</b> <ol style="list-style-type: none"> <li>1. Based on test during characterization, not tested in production.</li> <li>2. The wakeup times are measured from the wakeup event to the point in which the application code reads the first</li> </ol>				

Table 8.3-8 Low-power Mode Wakeup Timings

### 8.3.5 I/O Current Injection Characteristics

In general, I/O current injection due to external voltages below  $V_{SS}$  or above  $V_{DD}$  should be avoided during normal product operation. However, the analog component of the MCU is most likely to be affected by the injection current, but it is not easily clarified when abnormal injection accidentally happens. It is recommended to add a Schottky diode (pin to ground or pin to  $V_{DD}$ ) to pins that include analog function which may potentially injection currents.

Symbol	Parameter	Negative injection	Positive injection	Unit	Test Condition
$I_{INJ(PIN)}$	Injected current by a I/O Pin	-0	0	mA	Injected current on nReset pins
		-0	0		Injected current on PF2~PF5, PA10, PA11 and PB0~PB15 for analog input function
		-5	+5		Injected current on any other I/O except analog input pin

Table 8.3-9 I/O Current Injection Characteristics

### 8.3.6 I/O DC Characteristics

#### 8.3.6.1 PIN Input Characteristics

Symbol	Parameter	Min	Typ	Max	Unit	Test Conditions
$V_{IL}$	Input low voltage (Schmitt trigger)	0	-	$0.3 \cdot V_{DD}$	V	
	Input low voltage (TTL trigger)	0	-	0.8		$V_{DD} = 4.5 V$
		0	-	0.7		$V_{DD} = 2.7 V$
		0	-	0.5		$V_{DD} = 1.8 V$
$V_{IH}$	Input high voltage (Schmitt trigger)	$0.7 \cdot V_{DD}$	-	$V_{DD}$	V	
	Input high voltage (TTL trigger)	2	-	$V_{DD}$		$V_{DD} = 5.5 V$
		1.5	-	$V_{DD}$		$V_{DD} = 3.3 V$
		0.8	-	$V_{DD}$		$V_{DD} = 1.8 V$
$V_{HY}^{[1]}$	Hysteresis voltage of schmitt input	-	$0.2 \cdot V_{DD}$	-	V	
$I_{LK}^{[2]}$	Input leakage current	-1	-	1	$\mu A$	$V_{SS} < V_{IN} < V_{DD}$ , Open-drain or input only mode
		-1	-	1		$V_{DD} < V_{IN} < 5 V$ , Open-drain or input only mode on any other 5v tolerance pins
$R_{PU}^{[1]}$	Pull up resistor	45	52	57	k $\Omega$	
$R_{PD}^{[1]}$	Pull down resistor	45	52	57	k $\Omega$	

**Note:**

- Guaranteed by characterization result, not tested in production.
- Leakage could be higher than the maximum value, if abnormal injection happens.

Table 8.3-10 I/O Input Characteristics

8.3.6.2 I/O Output Characteristics

Symbol	Parameter	Min	Typ	Max	Unit	Test Conditions
$I_{SR}^{[*1][*2]}$	Source current for quasi-bidirectional mode and high level	-7	-7.75	-9	$\mu A$	$V_{DD} = 4.5 V$ $V_{IN} = (V_{DD} - 0.4) V$
		-7	-7.7	-9	$\mu A$	$V_{DD} = 2.7 V$ $V_{IN} = (V_{DD} - 0.4) V$
		-7	-7.6	-9	$\mu A$	$V_{DD} = 1.8 V$ $V_{IN} = (V_{DD} - 0.4) V$
	Source current for push-pull mode and high level	-5	-8	-10.5	mA	$V_{DD} = 4.5 V$ $V_{IN} = (V_{DD} - 0.4) V$
		-3.2	-5.2	-7.2	mA	$V_{DD} = 2.7 V$ $V_{IN} = (V_{DD} - 0.4) V$
		-2.1	-3.2	-4.2	mA	$V_{DD} = 1.8 V$ $V_{IN} = (V_{DD} - 0.4) V$
$I_{SK}^{[*1][*2]}$	Sink current for push-pull mode and low level	13	20	27	mA	$V_{DD} = 4.5 V$ $V_{IN} = 0.4 V$
		8.0	13	17.5	mA	$V_{DD} = 2.7 V$ $V_{IN} = 0.4 V$
		5.0	8	11	mA	$V_{DD} = 1.8 V$ $V_{IN} = 0.4 V$
$C_{IO}^{[*1]}$	I/O pin capacitance	-	5	-	pF	
<b>Note:</b> <ol style="list-style-type: none"> <li>1. Guaranteed by characterization result, not tested in production.</li> <li>2. The <math>I_{SR}</math> and <math>I_{SK}</math> must always respect the absolute maximum current and the sum of I/O, CPU and peripheral must not exceed <math>\Sigma I_{DD}</math> and <math>\Sigma I_{SS}</math>.</li> </ol>						

Table 8.3-11 I/O Output Characteristics

8.3.6.3 nRESET Input Characteristics

Symbol	Parameter	Min	Typ	Max	Unit	Test Conditions
$V_{ILR}$	Negative going threshold, nRESET	-	-	$0.3 \cdot V_{DD}$	V	
$V_{IHR}$	Positive going threshold, nRESET	$0.7 \cdot V_{DD}$	-	-	V	
$R_{RST}^{[*1]}$	Internal nRESET pull up resistor	45	53	47	k $\Omega$	
$t_{FR}^{[*1]}$	nRESET input filtered pulse time	-	24	-	$\mu$ S	Normal run and Idle mode
		-	35	-		Fast wake up Power-down mode
		-	45	-		Power-down mode
		-	0.1	-		Deep Power-down mode
<b>Note:</b>						
1. Guaranteed by characterization result, not tested in production.						
2. It is recommended to use 10 k $\Omega$ pull-up resistor and 10 $\mu$ F capacitor on nRESET pin						

Table 8.3-12 nRESET Input Characteristics

### 8.4 AC Electrical Characteristics

#### 8.4.1 48 MHz Internal High Speed RC Oscillator (HIRC)

The 48 MHz RC oscillator is calibrated in production.

Symbol.	Parameter	Min	Typ	Max	Unit	Test Conditions
$V_{DD}$	Operating voltage	1.75	-	5.5	V	
$f_{HIRC}$	Oscillator frequency	47.52	48	48.48	MHz	$T_A = 25\text{ }^\circ\text{C}$ , $V_{DD} = 3.3\text{V}$
	Frequency drift over temperature and voltage	-1	-	1	%	$T_A = 25\text{ }^\circ\text{C}$ , $V_{DD} = 3.3\text{V}$
		$-2^{[*1]}$	-	$2^{[*1]}$	%	$T_A = -20\text{ }^\circ\text{C} \sim +105\text{ }^\circ\text{C}$ , $V_{DD} = 1.75 \sim 5.5\text{V}$
		$-2.8^{[*1]}$	-	$2.8^{[*1]}$	%	$T_A = -40\text{ }^\circ\text{C} \sim +105\text{ }^\circ\text{C}$ , $V_{DD} = 1.75 \sim 5.5\text{V}$
$I_{HIRC}^{[*1]}$	Operating current	-	500	800	$\mu\text{A}$	
$T_S^{[*2]}$	Stable time	-	14	16	$\mu\text{S}$	$T_A = -40\text{ }^\circ\text{C} \sim +105\text{ }^\circ\text{C}$ , $V_{DD} = 1.75 \sim 5.5\text{V}$
<b>Note:</b> <ol style="list-style-type: none"> <li>1. Guaranteed by characterization result, not tested in production.</li> <li>2. Guaranteed by design.</li> </ol>						

Table 8.4-1 48 MHz Internal High Speed RC Oscillator(HIRC) Characteristics

**8.4.2 4 MHz Internal Median Speed RC Oscillator (MIRC)**

The 4 MHz RC oscillator is calibrated in production.

Symbol.	Parameter	Min	Typ	Max	Unit	Test Conditions
V <sub>DD</sub>	Operating voltage	1.75	-	5.5	V	
F <sub>MIRC</sub>	Oscillator frequency	3.951	4.032	4.112	MHz	T <sub>A</sub> = 25 °C, V <sub>DD</sub> = 3.3V
	Frequency drift over temperature and voltage	-2	-	2	%	T <sub>A</sub> = 25 °C, V <sub>DD</sub> = 3.3V
		-10 <sup>[1]</sup>	-	10 <sup>[1]</sup>	%	T <sub>A</sub> = -40°C ~ +105 °C, V <sub>DD</sub> = 1.75 ~ 5.5V
I <sub>MIRC</sub> <sup>[1]</sup>	Operating current	-	-	30	μA	
T <sub>S</sub> <sup>[2]</sup>	Stable time	-	-	24	μS	T <sub>A</sub> = -40°C ~ +105 °C, V <sub>DD</sub> = 1.75 ~ 5.5V
<b>Note:</b> <ol style="list-style-type: none"> <li>1. Guaranteed by characterization result, not tested in production.</li> <li>2. Guaranteed by design.</li> </ol>						

Table 8.4-2 4 MHz Internal Median Speed RC Oscillator (MIRC) Characteristics

8.4.3 38.4 kHz Internal Low Speed RC Oscillator (LIRC)

Symbol	Parameter	Min <sup>[1]</sup>	Typ	Max <sup>[1]</sup>	Unit	Test Conditions
V <sub>DD</sub>	Operating voltage	1.75	-	5.5	V	
F <sub>LRC</sub> <sup>[2]</sup>	Oscillator frequency	-	38.4	-	kHz	T <sub>A</sub> = 25 °C, V <sub>DD</sub> = 3.3V
	Frequency drift over temperature and voltage	-2	-	2	%	T <sub>A</sub> = 25 °C, V <sub>DD</sub> = 3.3V
		-15	-	15	%	T <sub>A</sub> = -40~105°C V <sub>DD</sub> = 1.75V~5.5V Without software calibration
I <sub>LRC</sub>	Operating current	-	0.85	1.3	μA	V <sub>DD</sub> = 3.3V
T <sub>S</sub>	Stable time	-	-	70	μS	T <sub>A</sub> = -40~105°C V <sub>DD</sub> = 1.75V~5.5V
<p><b>Note:</b></p> <ol style="list-style-type: none"> <li>1. Guaranteed by characterization, not tested in production.</li> <li>2. The 38.4 kHz low speed RC oscillator can be calibrated by user.</li> <li>3. Guaranteed by design.</li> </ol>						

Table 8.4-3 38.4 kHz Internal Low Speed RC Oscillator (LIRC) Characteristics

**8.4.4 External 4~32 MHz High Speed Crystal/Ceramic Resonator (HXT) Characteristics**

The high-speed external (HXT) clock can be supplied with a 4 to 32 MHz crystal/ceramic resonator oscillator. All the information given in this section are based on characterization results obtained with typical external components. In the application, the external components have to be placed as close as possible to the XT1\_IN and XT1\_Out pins and must not be connected to any other devices in order to minimize output distortion and startup stabilization time. Refer to the crystal resonator manufacturer for more details on the resonator characteristics (frequency, package, accuracy).

Symbol	Parameter	Min <sup>[1]</sup>	Typ	Max <sup>[1]</sup>	Unit	Test Conditions
V <sub>DD</sub>	Operating voltage	1.75	-	5.5	V	
R <sub>f</sub>	Internal feedback resistor	-	1000	-	kΩ	
f <sub>HXT</sub>	Oscillator frequency	4	-	32	MHz	
I <sub>HXT</sub>	Current consumption	-	45	150	μA	4 MHz, Gain = L0, C <sub>L</sub> = 12.5 pF, ESR = 120Ω
		-	80	250		8 MHz, Gain = L1, C <sub>L</sub> = 12.5 pF, ESR = 60Ω
		-	150	430		12 MHz, Gain = L2, C <sub>L</sub> = 12.5 pF, ESR = 25Ω
		-	230	600		16 MHz, Gain = L3, C <sub>L</sub> = 12.5 pF, ESR = 25Ω
		-	280	760		24 MHz, Gain = L4, C <sub>L</sub> = 12.5 pF, ESR = 25Ω
		-	630	1550		32 MHz, Gain = L7, C <sub>L</sub> = 12.5 pF, ESR = 25Ω
T <sub>s</sub>	Stable time	-	2550	2950	μs	4 MHz, Gain = L0, C <sub>L</sub> = 12.5 pF, ESR = 120Ω
		-	900	1250		8 MHz, Gain = L1, C <sub>L</sub> = 12.5 pF, ESR = 60Ω
		-	550	850		12 MHz, Gain = L2, C <sub>L</sub> = 12.5 pF, ESR = 25Ω
		-	400	700		16 MHz, Gain = L3, C <sub>L</sub> = 12.5 pF, ESR = 25Ω
		-	300	650		24 MHz, Gain = L4, C <sub>L</sub> = 12.5 pF, ESR = 25Ω
		-	250	610		32 MHz, Gain = L7, C <sub>L</sub> = 12.5 pF, ESR = 25Ω
D <sub>U<sub>HXT</sub></sub>	Duty cycle	40	-	60	%	
V <sub>pp</sub>	Peak-to-peak amplitude	-	1.6	-	V	
<b>Note:</b>						
1. Guaranteed by characterization, not tested in production.						

Table 8.4-4 External 4~32 MHz High Speed Crystal (HXT) Oscillator

Symbol	Parameter	Min	Typ	Max <sup>[1]</sup>	Unit	Test Conditions
Rs	Equivalent series resisotr (ESR)	-	-	120	Ω	Crystal at 4 MHz, C <sub>L</sub> = 12.5 pF, Gain = L0
		-	-	60		Crystal at 8 MHz, C <sub>L</sub> = 12.5 pF, Gain = L1
		-	-	25		Crystal at 12 MHz, C <sub>L</sub> = 12.5 pF, Gain = L2
		-	-	25		Crystal at 16 MHz, C <sub>L</sub> = 12.5 pF, Gain = L3
		-	-	25		Crystal at 24 MHz, C <sub>L</sub> = 12.5 pF, Gain = L4
		-	-	25		Crystal at 32 MHz, C <sub>L</sub> = 12.5 pF, Gain = L7

**Note:**

1. Guaranteed by characterization, not tested in production.
2. Safety factor (S<sub>f</sub>) must be higher than 5 for HXT to determine the oscillator safe operation during the application life. If Safety factor isn't enough, the HXT gain need be changed to higher driving level.

$$S_f = \frac{-R}{\text{Crystal ESR}} = \frac{R_{ADD} + R_S}{R_S}$$

R<sub>ADD</sub>: The value of smallest series resistance preventing the oscillator from starting up successfully. This resistance is only used to measure Safety factor (S<sub>f</sub>) of crystal in engineer stage, not for mass producton.

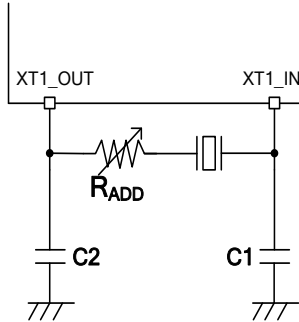

Table 8.4-5 External 4~32 MHz High Speed Crystal Characteristics

8.4.4.1 Typical Crystal Application Circuits

For C1 and C2, it is recommended to use high-quality external ceramic capacitors in 10 pF ~ 20 pF range, designed for high-frequency applications, and selected to match the requirements of the crystal or resonator. The crystal manufacturer typically specifies a load capacitance which is the series combination of C1 and C2. PCB and MCU pin capacitance must be included (8 pF can be used as a rough estimate of the combined pin and board capacitance) when sizing C1 and C2.

CRYSTAL	C1	C2	R1
4 MHz ~ 32 MHz	10 ~ 20 pF	10 ~ 20 pF	without

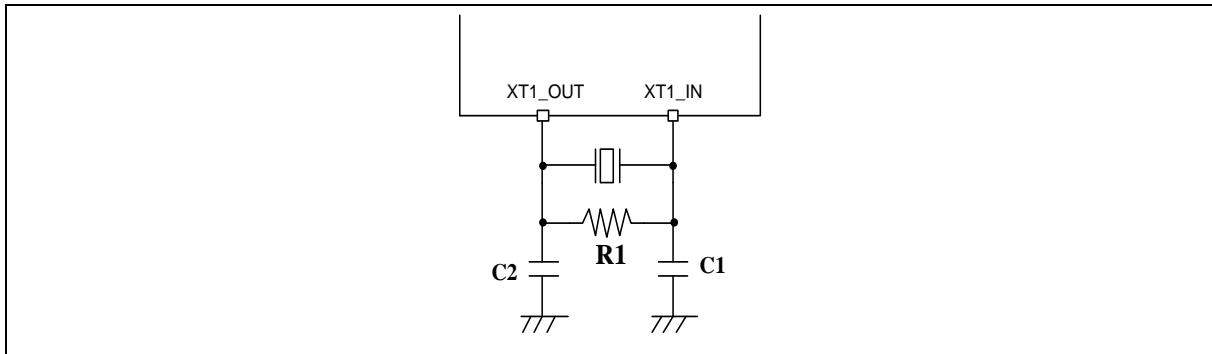

Figure 8.4-1 Typical Crystal Application Circuit

### 8.4.5 External 4~32 MHz High Speed Clock Input Signal Characteristics

For clock input mode, the HXT oscillator is switched off and XT1\_IN is a standard input pin to receive external clock. The external clock signal has to respect the table below. The characteristics result from tests performed uses a waveform generator.

Symbol	Parameter	Min <sup>[1]</sup>	Typ	Max <sup>[1]</sup>	Unit	Test Conditions
$f_{HXT\_ext}$	External user clock source frequency	1	-	32	MHz	
$t_{CHCX}$	Clock high time	8	-	-	nS	
$t_{CLCX}$	Clock low time	8	-	-	nS	
$t_{CLCH}$	Clock rise time	-	-	10	nS	Low (10%) to high level (90%) rise time
$t_{CHCL}$	Clock fall time	-	-	10	nS	High (90%) to low level (10%) fall time
$Du_{E\_HXT}$	Duty cycle	40	-	60	%	
$V_{IH}$	Input high voltage	$0.7 \cdot V_{DD}$	-	$V_{DD}$	V	
$V_{IL}$	Input low voltage	$V_{SS}$	-	$0.3 \cdot V_{DD}$	V	

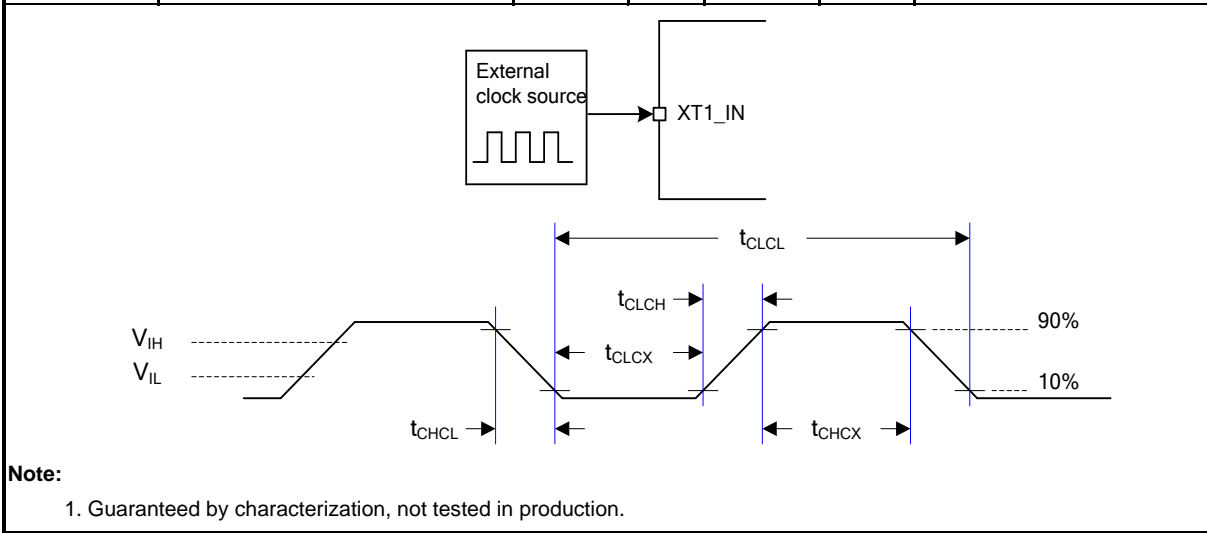

Table 8.4-6 External 4~32 MHz High Speed Clock Input Signal

**8.4.6 External 32.768 kHz Low Speed Crystal/Ceramic Resonator (LXT) Characteristics for M251xC/M251xD/M252xC/M252xD**

The low-speed external (LXT) clock can be supplied with a 32.768 kHz crystal/ceramic resonator oscillator. All the information given in this section are based on characterization results obtained with typical external components. In the application, the external components have to be placed as close as possible to the X32\_OUT and X32\_IN pins and must not be connected to any other devices in order to minimize output distortion and startup stabilization time. Refer to the crystal resonator manufacturer for more details on the resonator characteristics (frequency, package, accuracy).

Symbol	Parameter	Min <sup>[1]</sup>	Typ	Max <sup>[1]</sup>	Unit	Test Conditions
V <sub>DD</sub>	Operation voltage	1.75	-	5.5	V	
T <sub>LXT</sub>	Temperature range	-40	-	105	°C	
R <sub>f</sub>	Internal feedback resistor	-	15	-	MΩ	
F <sub>LXT</sub>	Oscillator frequency	32.768			kHz	
I <sub>LXT</sub>	Current consumption from V <sub>DD</sub>	-	0.6	2.0	μA	ESR=35 kΩ, C <sub>L</sub> = 12.5 pF, Gain = L1
		-	0.74	2.5		ESR=70 kΩ, C <sub>L</sub> = 12.5 pF, Gain = L2
		-	1	3.0		ESR=70 kΩ, C <sub>L</sub> = 12.5 pF, Gain = L3
T <sub>S<sub>LXT</sub></sub>	Stable time	-	2	-	S	
Du <sub>LXT</sub>	Duty cycle	30	-	70	%	
V <sub>pp</sub> <sup>[1]</sup>	Peak-to-peak amplitude	-	0.4	-	V	
<b>Note:</b>						
1. Guaranteed by characterization, not tested in production.						

Table 8.4-7 External 32.768 kHz Low Speed Crystal (LXT) Oscillator

Symbol	Parameter	Min	Typ	Max	Unit	Test Conditions
R <sub>s</sub>	Equivalent Series Resistor (ESR)	-	35	70	kΩ	Crystal at 32.768 kHz

Table 8.4-8 External 32.768 kHz Low Speed Crystal Characteristics

**8.4.6.1 Typical Crystal Application Circuits**

CRYSTAL	C1	C2	R1
32.768 kHz, ESR < 70 kΩ	5 ~ 20 pF	5 ~ 20 pF	without

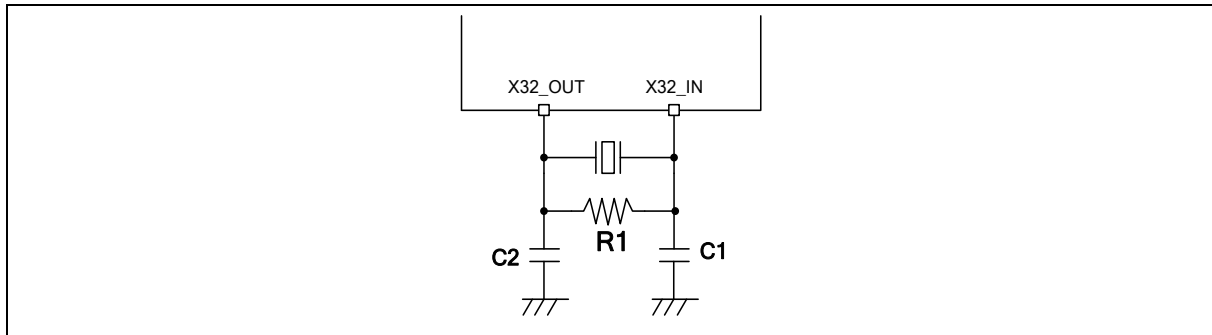

Figure 8.4-2 Typical 32.768 kHz Crystal Application Circuit

**8.4.7 External 32.768 kHz Low Speed Crystal/Ceramic Resonator (LXT) Characteristics for M251xE/M251xG/M252xE/M252xG**

The low-speed external (LXT) clock can be supplied with a 32.768 kHz crystal/ceramic resonator oscillator. All the information given in this section are based on characterization results obtained with typical external components. In the application, the external components have to be placed as close as possible to the X32\_OUT and X32\_IN pins and must not be connected to any other devices in order to minimize output distortion and startup stabilization time. Refer to the crystal resonator manufacturer for more details on the resonator characteristics (frequency, package, accuracy).

Symbol	Parameter	Min <sup>[1]</sup>	Typ	Max <sup>[1]</sup>	Unit	Test Conditions
V <sub>BAT</sub>	Operation voltage	1.75	-	5.5	V	
T <sub>LXT</sub>	Temperature range	-40	-	105	°C	
R <sub>f</sub>	Internal feedback resistor	-	15	-	MΩ	
F <sub>LXT</sub>	Oscillator frequency	32.768			kHz	
		-	0.76	5		ESR=35 kΩ, C <sub>L</sub> = 12.5 pF, Gain = L3
		-	0.87	5.3		ESR=35 kΩ, C <sub>L</sub> = 12.5 pF, Gain = L4
		-	0.97	5.55		ESR=35 kΩ, C <sub>L</sub> = 12.5 pF, Gain = L5
		-	1.4	6.4		ESR=70 kΩ, C <sub>L</sub> = 12.5 pF, Gain = L6
		-	1.f	7.5		ESR=70 kΩ, C <sub>L</sub> = 12.5 pF, Gain = L7
T <sub>sLXT</sub>	Stable time	-	2	-	S	
Du <sub>LXT</sub>	Duty cycle	30	-	70	%	
V <sub>pp</sub>	Peak-to-peak amplitude	-	0.3	-	V	
<b>Note:</b>						
1. Guaranteed by characterization, not tested in production.						

Table 8.4-9 External 32.768 kHz Low Speed Crystal (LXT) Oscillator

Symbol	Parameter	Min	Typ	Max	Unit	Test Conditions
R <sub>s</sub>	Equivalent Series Resistor (ESR)	-	35	70	kΩ	Crystal at 32.768 kHz

Table 8.4-10 External 32.768 kHz Low Speed Crystal Characteristics

**8.4.7.1 Typical Crystal Application Circuits**

CRYSTAL	C1	C2	R1
32.768 kHz, ESR < 70 KΩ	5 ~ 20 pF	5 ~ 20 pF	without

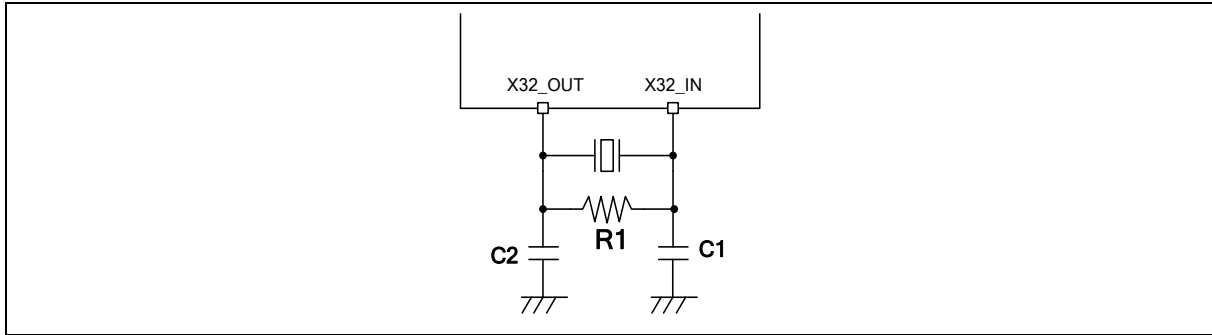

Figure 8.4-3 Typical 32.768 kHz Crystal Application Circuit

### 8.4.8 External 32.768 kHz Low Speed Clock Input Signal Characteristics

For clock input mode the LXT oscillator is switched off and X32\_IN is a standard input pin to receive external clock. The external clock signal has to respect the table below. The characteristics result from tests performed uses a waveform generator.

Symbol	Parameter	Min <sup>[1]</sup>	Typ	Max <sup>[1]</sup>	Unit	Test Conditions
$f_{LXT\_ext}$	External clock source frequency	-	32.768	-	kHz	
$t_{CHCX}$	Clock high time	450	-	-	nS	
$t_{CLCX}$	Clock low time	450	-	-	nS	
$t_{CLCH}$	Clock rise time	-	-	50	nS	Low (10%) to high level (90%) rise time
$t_{CHCL}$	Clock fall time	-	-	50	nS	High (90%) to low level (10%) fall time
$DuE\_LXT$	Duty cycle	30	-	70	%	
$Xin\_VIH$	LXT input pin input high voltage	$0.7 \cdot V_{DD}$	-	$V_{DD}$	V	$V_{BAT} = V_{DD}$
$Xin\_VIL$	LXT input pin input low voltage	$V_{SS}$	-	$0.3 \cdot V_{DD}$	V	$V_{BAT} = V_{DD}$

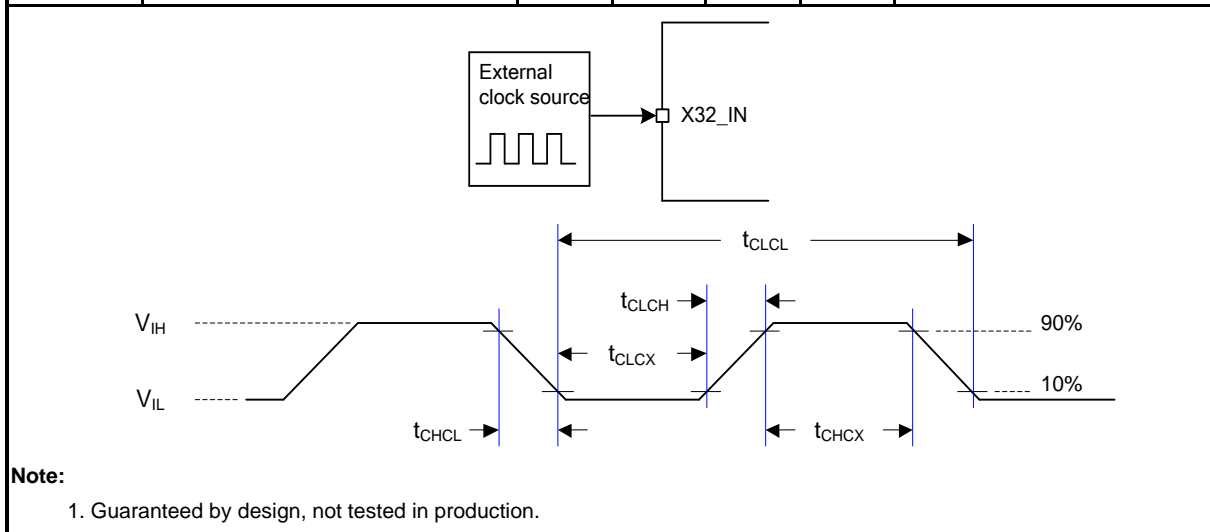

Table 8.4-11 External 32.768 kHz Low Speed Clock Input Signal

8.4.9 PLL Characteristics

Symbol	Parameter	Min <sup>[1]</sup>	Typ	Max <sup>[1]</sup>	Unit	Test Conditions
$f_{PLL\_in}$	PLL input clock	4	-	24	MHz	
$f_{PLL\_OUT}$	PLL multiplier output clock	16	-	100	MHz	
$f_{PLL\_REF}$	PLL reference clock	4	-	8	MHz	
$f_{PLL\_VCO}$	PLL voltage controlled oscillator	64	-	100	MHz	
$T_L$	PLL locking time	-	-	100	$\mu$ S	
Jitter <sup>[2]</sup>	Cycle-to-cycle Jitter	-	-	500	pS	
$I_{DD}$	Power consumption	-	1	2	mA	$V_{DD} = 5.5V$ at $f_{PLL\_VCO} = 100$ MHz

Note:

1. Guaranteed by characterization, not tested in production
2. Guaranteed by design, not tested in production

Table 8.4-12 PLL Characteristics

8.4.10 I/O AC Characteristics

Symbol	Parameter	Typ.	Max <sup>[*1]</sup>	Unit	Test Conditions <sup>[*2]</sup>			
$t_{f(I)out}$	Output high (90%) to low level (10%) fall time (Normal Slew Rate)	-	6.5	nS	$C_L = 30\text{ pF}, V_{DD} \geq 4.5\text{ V}$			
		-	4.5		$C_L = 10\text{ pF}, V_{DD} \geq 4.5\text{ V}$			
		-	10		$C_L = 30\text{ pF}, V_{DD} \geq 2.7\text{ V}$			
		-	7		$C_L = 10\text{ pF}, V_{DD} \geq 2.7\text{ V}$			
		-	16.5		$C_L = 30\text{ pF}, V_{DD} \geq 1.8\text{ V}$			
		-	11.5		$C_L = 10\text{ pF}, V_{DD} \geq 1.8\text{ V}$			
	Output high (90%) to low level (10%) fall time (High Slew Rate)	-	5		$C_L = 30\text{ pF}, V_{DD} \geq 4.5\text{ V}$			
		-	3.5		$C_L = 10\text{ pF}, V_{DD} \geq 4.5\text{ V}$			
		-	8		$C_L = 30\text{ pF}, V_{DD} \geq 2.7\text{ V}$			
		-	5		$C_L = 10\text{ pF}, V_{DD} \geq 2.7\text{ V}$			
		-	12.5		$C_L = 30\text{ pF}, V_{DD} \geq 1.8\text{ V}$			
		-	8		$C_L = 10\text{ pF}, V_{DD} \geq 1.8\text{ V}$			
		$t_{r(I)out}$	Output low (10%) to high level (90%) rise time (Normal Slew Rate)		-	7.5	nS	$C_L = 30\text{ pF}, V_{DD} \geq 4.5\text{ V}$
					-	5		$C_L = 10\text{ pF}, V_{DD} \geq 4.5\text{ V}$
-	12			$C_L = 30\text{ pF}, V_{DD} \geq 2.7\text{ V}$				
-	8			$C_L = 10\text{ pF}, V_{DD} \geq 2.7\text{ V}$				
-	20.5			$C_L = 30\text{ pF}, V_{DD} \geq 1.8\text{ V}$				
-	13.5			$C_L = 10\text{ pF}, V_{DD} \geq 1.8\text{ V}$				
Output low (10%) to high level (90%) rise time (High Slew Rate)	-	6.5	nS	$C_L = 30\text{ pF}, V_{DD} \geq 4.5\text{ V}$				
	-	4.5		$C_L = 10\text{ pF}, V_{DD} \geq 4.5\text{ V}$				
	-	10		$C_L = 30\text{ pF}, V_{DD} \geq 2.7\text{ V}$				
	-	6.5		$C_L = 10\text{ pF}, V_{DD} \geq 2.7\text{ V}$				
	-	18		$C_L = 30\text{ pF}, V_{DD} \geq 1.8\text{ V}$				
	-	10.5		$C_L = 10\text{ pF}, V_{DD} \geq 1.8\text{ V}$				
$f_{max(I)out}^{[*3]}$	I/O maximum frequency (Normal Slew Rate)	-	47	MHz	$C_L = 30\text{ pF}, V_{DD} \geq 4.5\text{ V}$			
		-	70		$C_L = 10\text{ pF}, V_{DD} \geq 4.5\text{ V}$			
		-	30		$C_L = 30\text{ pF}, V_{DD} \geq 2.7\text{ V}$			
		-	44		$C_L = 10\text{ pF}, V_{DD} \geq 2.7\text{ V}$			
		-	18		$C_L = 30\text{ pF}, V_{DD} \geq 1.8\text{ V}$			

	I/O maximum frequency (High Slew Rate)	-	26	MHz	$C_L = 10 \text{ pF}, V_{DD} \geq 1.8 \text{ V}$
		-	55		$C_L = 30 \text{ pF}, V_{DD} \geq 4.5 \text{ V}$
		-	80		$C_L = 10 \text{ pF}, V_{DD} \geq 4.5 \text{ V}$
		-	36		$C_L = 30 \text{ pF}, V_{DD} \geq 2.7 \text{ V}$
		-	56		$C_L = 10 \text{ pF}, V_{DD} \geq 2.7 \text{ V}$
		-	21		$C_L = 30 \text{ pF}, V_{DD} \geq 1.8 \text{ V}$
		-	35		$C_L = 10 \text{ pF}, V_{DD} \geq 1.8 \text{ V}$
$I_{DIO}^{[4]}$	I/O dynamic current consumption	2.77	-	mA	$C_L = 30 \text{ pF}, V_{DD} = 3.3 \text{ V},$ $f_{(IO)out} = 24 \text{ MHz}$
		1.19	-		$C_L = 10 \text{ pF}, V_{DD} = 3.3 \text{ V},$ $f_{(IO)out} = 24 \text{ MHz}$
		0.69	-		$C_L = 30 \text{ pF}, V_{DD} = 3.3 \text{ V},$ $f_{(IO)out} = 6 \text{ MHz}$
		0.3	-		$C_L = 10 \text{ pF}, V_{DD} = 3.3 \text{ V},$ $f_{(IO)out} = 6 \text{ MHz}$
<p><b>Note:</b></p> <ol style="list-style-type: none"> <li>1. Guaranteed by characterization result, not tested in production.</li> <li>2. <math>C_L</math> is a external capacitive load to simulate PCB and device loading.</li> <li>3. The maximum frequency is defined by <math>f_{max} = \frac{2}{3 \times (t_f + t_r)}</math>.</li> <li>4. The I/O dynamic current consumption is defined by <math>I_{DIO} = V_{DD} \times f_{IO} \times (C_{IO} + C_L)</math></li> </ol>					

Table 8.4-13 I/O AC Characteristics

## 8.5 Analog Characteristics

### 8.5.1 LDO

Symbol	Parameter	Min	Typ	Max	Unit	Test Condition
V <sub>DD</sub>	Power supply	1.75	-	5.5	V	
V <sub>LDO</sub>	Output voltage	-	1.5	-	V	
T <sub>A</sub>	Temperature	-40	-	105	°C	

**Note:**

1. It is recommended a 0.1μF bypass capacitor is connected between V<sub>DD</sub> and the closest V<sub>SS</sub> pin of the device.
2. For ensuring power stability, a 1μF capacitor must be connected between LDO\_CAP pin and the closest V<sub>SS</sub> pin of the device.
3. V<sub>LDO</sub> is only used to supply internal power.

### 8.5.2 Reset and Power Control Block Characteristics

The parameters in the table below are derived from tests performed under ambient temperature.

Symbol	Parameter	Min	Typ	Max	Unit	Test Conditions
I <sub>POR</sub> <sup>[1]</sup>	POR operating current	-	70	100	μA	AV <sub>DD</sub> = 5.5V
I <sub>LVR</sub> <sup>[1]</sup>	LVR operating current	-	0.3	3		AV <sub>DD</sub> = 5.5V
I <sub>BOD</sub> <sup>[1]</sup>	BOD operating current	-	40	60		AV <sub>DD</sub> = 5.5V, Normal mode
		-	3	6	AV <sub>DD</sub> = 5.5V, Low Power mode	
V <sub>POR</sub>	POR reset voltage	1.40	1.5	1.65	V	-
V <sub>LVR</sub>	LVR reset voltage	1.55	1.6	1.7		
V <sub>BOD</sub>	BOD brown-out detect voltage (Falling edge)	1.70	1.80	1.90		BODVL = 1
		1.90	2.00	2.10		BODVL = 2
		2.30	2.40	2.50		BODVL = 3
		2.60	2.70	2.80		BODVL = 4
		2.90	3.00	3.10		BODVL = 5
		3.60	3.70	3.80		BODVL = 6
		4.25	4.40	4.50		BODVL = 7
		BOD brown-out detect voltage (Rising edge)	1.76	1.88		2.00
1.96	2.08		2.20	BODVL = 2		
2.36	2.48		2.60	BODVL = 3		
2.66	2.78		2.90	BODVL = 4		
2.96	3.08		3.20	BODVL = 5		
3.66	3.78		3.90	BODVL = 6		
4.31	4.48		4.60	BODVL = 7		
T <sub>LVR_SU</sub> <sup>[1]</sup>	LVR startup time		-	200	2000	μS

$T_{LVR\_RE}^{[1]}$	LVR respond time	-	20	50		-
$T_{BOD\_SU}^{[1]}$	BOD startup time	-	1000	2000		-
$T_{BOD\_RE}^{[1]}$	BOD respond time	-	1	2		Normal mode BODDGSEL = 3 $f_{HCLK} = 48\text{ MHz}$
		-	1000	30000	Low Power mode	
$R_{VDDR}^{[1]}$	$V_{DD}$ rise time rate	10	-	20000	$\mu\text{S/V}$	POR Enabled
$R_{VDDF}^{[1]}$	$V_{DD}$ fall time rate	10	-	-		POR Enabled
		250	-	-		LVR Enabled
		10	-	-		BOD Enabled with Normal mode BODDGSEL = 3 $f_{HCLK} = 48\text{ MHz}$
<b>Note:</b> 1. Guaranteed by characterization, not tested in production. 2. Design for specified applcaiton.						

Table 8.5-1 Reset and Power Control Unit

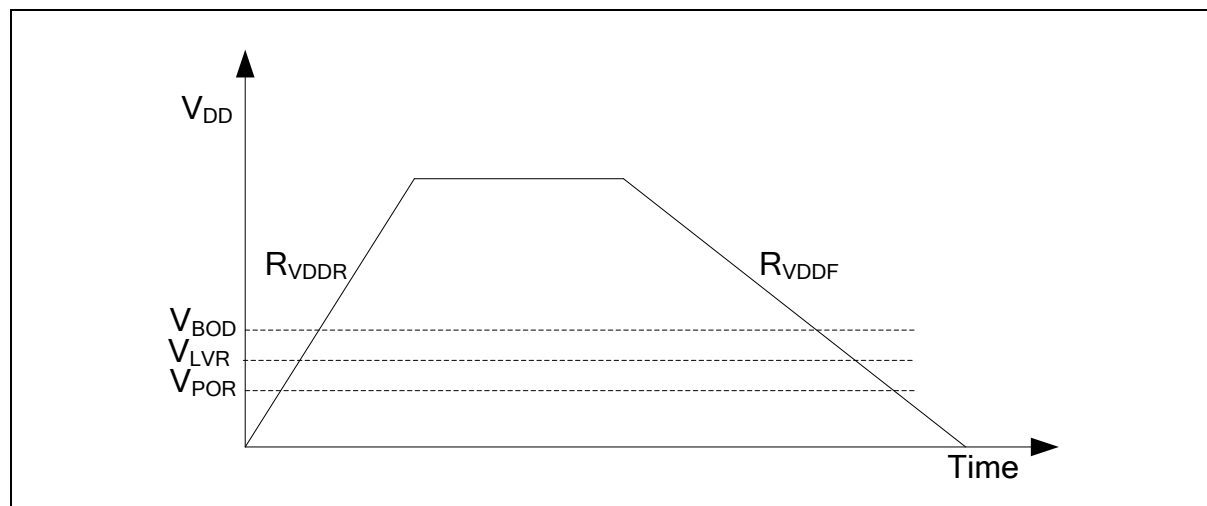

Figure 8.5-1 Power Ramp Up/Down Condition

8.5.3 12-bit SAR Analog to Digital Converter (ADC)

Symbol	Parameter	Min	Typ	Max	Unit	Test Conditions
T <sub>A</sub>	Temperature	-40	-	105	°C	
AV <sub>DD</sub>	Analog operating voltage	1.75	-	5.5	V	V <sub>DD</sub> = AV <sub>DD</sub>
V <sub>REF</sub>	Reference voltage	1.75	-	AV <sub>DD</sub>	V	
V <sub>IN</sub>	ADC channel input voltage	0	-	V <sub>REF</sub>	V	
I <sub>ADC</sub> <sup>[1]</sup>	ADC Operating current (AV <sub>DD</sub> + V <sub>REF</sub> current)	-	1000	-	µA	AV <sub>DD</sub> = V <sub>DD</sub> = V <sub>REF</sub> = 3.3 V F <sub>ADC</sub> = 16 MHz T <sub>CONV</sub> = 22 * T <sub>ADC</sub>
N <sub>R</sub>	Resolution	12			Bit	
F <sub>ADC</sub> <sup>[1]</sup> 1/T <sub>ADC</sub>	ADC Clock frequency	4	-	16	MHz	
T <sub>SMP</sub>	Sampling Time	1	-	256	1/F <sub>ADC</sub>	T <sub>SMP</sub> = ( EXTSMPT(EADC_SCTLx[31:24]) + 1 ) * T <sub>ADC</sub>
T <sub>CONV</sub>	Conversion time	22	-	277	1/F <sub>ADC</sub>	T <sub>CONV</sub> = T <sub>SMP</sub> + 21 * T <sub>ADC</sub>
F <sub>SPS</sub> <sup>[1]</sup>	Sampling Rate	250	-	730	kSPS	F <sub>SPS</sub> = F <sub>ADC</sub> / T <sub>CONV</sub> EXTSMPT(ADC_ESMPCTL[7:0]) = 0
T <sub>EN</sub>	Enable to ready time	32	-	-	µs	
INL <sup>[1]</sup>	Integral Non-Linearity Error	-3	-	+3	LSB	V <sub>REF</sub> = AV <sub>DD</sub> , R <sub>EX</sub> = 50Ω except TSSOP20 and TSSOP28
		-TBD	-	+TBD	LSB	V <sub>REF</sub> = AV <sub>DD</sub> , R <sub>EX</sub> = 50Ω TSSOP20 and TSSOP28
DNL <sup>[1]</sup>	Differential Non-Linearity Error	-1	-	+3	LSB	V <sub>REF</sub> = AV <sub>DD</sub> , R <sub>EX</sub> = 50Ω except TSSOP20 and TSSOP28
		-TBD	-	+TBD	LSB	V <sub>REF</sub> = AV <sub>DD</sub> , R <sub>EX</sub> = 50Ω TSSOP20 and TSSOP28
E <sub>G</sub> <sup>[1]</sup>	Gain error	-6	-	+6	LSB	V <sub>REF</sub> = AV <sub>DD</sub> , R <sub>EX</sub> = 50Ω except TSSOP20 and TSSOP28
		-TBD	-	+TBD	LSB	V <sub>REF</sub> = AV <sub>DD</sub> , R <sub>EX</sub> = 50Ω TSSOP20 and TSSOP28
E <sub>O</sub> <sup>[1]T</sup>	Offset error	-3	-	+3	LSB	V <sub>REF</sub> = AV <sub>DD</sub> , R <sub>EX</sub> = 50Ω except TSSOP20 and TSSOP28
		-TBD	-	+TBD	LSB	V <sub>REF</sub> = AV <sub>DD</sub> , R <sub>EX</sub> = 50Ω TSSOP20 and TSSOP28
E <sub>A</sub> <sup>[1]</sup>	Absolute Error	-1.5	-	+6.5	LSB	V <sub>REF</sub> = AV <sub>DD</sub> , R <sub>EX</sub> = 50Ω except TSSOP20 and TSSOP28
		-TBD	-	+TBD	LSB	V <sub>REF</sub> = AV <sub>DD</sub> , R <sub>EX</sub> = 50Ω TSSOP20 and TSSOP28
ENOB <sup>[1]</sup>	Effective number of bits	10	-	-	bits	F <sub>ADC</sub> = 16 MHz

Symbol	Parameter	Min	Typ	Max	Unit	Test Conditions
SINAD <sup>[*1]</sup>	Signal-to-noise and distortion ratio	-	64	-	dB	AV <sub>DD</sub> = V <sub>DD</sub> = V <sub>REF</sub> = 3.3 V Input Frequency = 10 kHz T <sub>A</sub> = 25 °C
SNR <sup>[*1]</sup>	Signal-to-noise ratio	-	64	-		
THD <sup>[*1]</sup>	Total harmonic distortion	-	-65	-		
C <sub>IN</sub> <sup>[*1]</sup>	Internal Capacitance	-	26	30	pF	
R <sub>IN</sub> <sup>[*1]</sup>	Internal Switch Resistance	-	0.5	-	kΩ	
R <sub>EX</sub> <sup>[*1]</sup>	External input impedance	-	-	33	kΩ	

**Note:**

1. Guaranteed by characterization result, not tested in production.
2. R<sub>EX</sub> max formula is used to determine the maximum external impedance allowed for 1/4 LSB error. N = 12 (based on 12-bit resolution) and k is the number of sampling clocks (T<sub>SMP</sub>). C<sub>EX</sub> represents the capacitance of PCB and pad and is combined with R<sub>EX</sub> into a low-pass filter. Once the R<sub>EX</sub> and C<sub>EX</sub> values are too large, it is possible to filter the real signal and reduce the ADC accuracy.

$$R_{EX} < \frac{k}{f_{ADC} \times (C_{IN} + C_{EX}) \times \ln(2^{N+2})} - R_{IN}$$

Table 8.5-2 ADC Characteristics

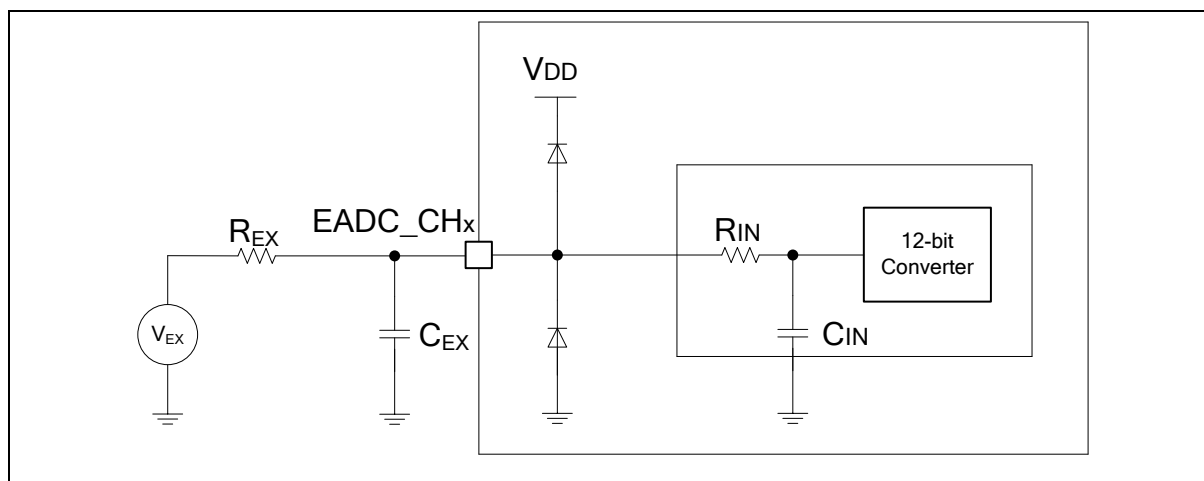

**Note:** Injection current is an important topic of ADC accuracy. Injecting current on any analog input pins should be avoided to protect the conversion being performed on another analog input. It is recommended to add Schottky diodes (pin to ground and pin to power) to analog pins which may potentially inject currents.

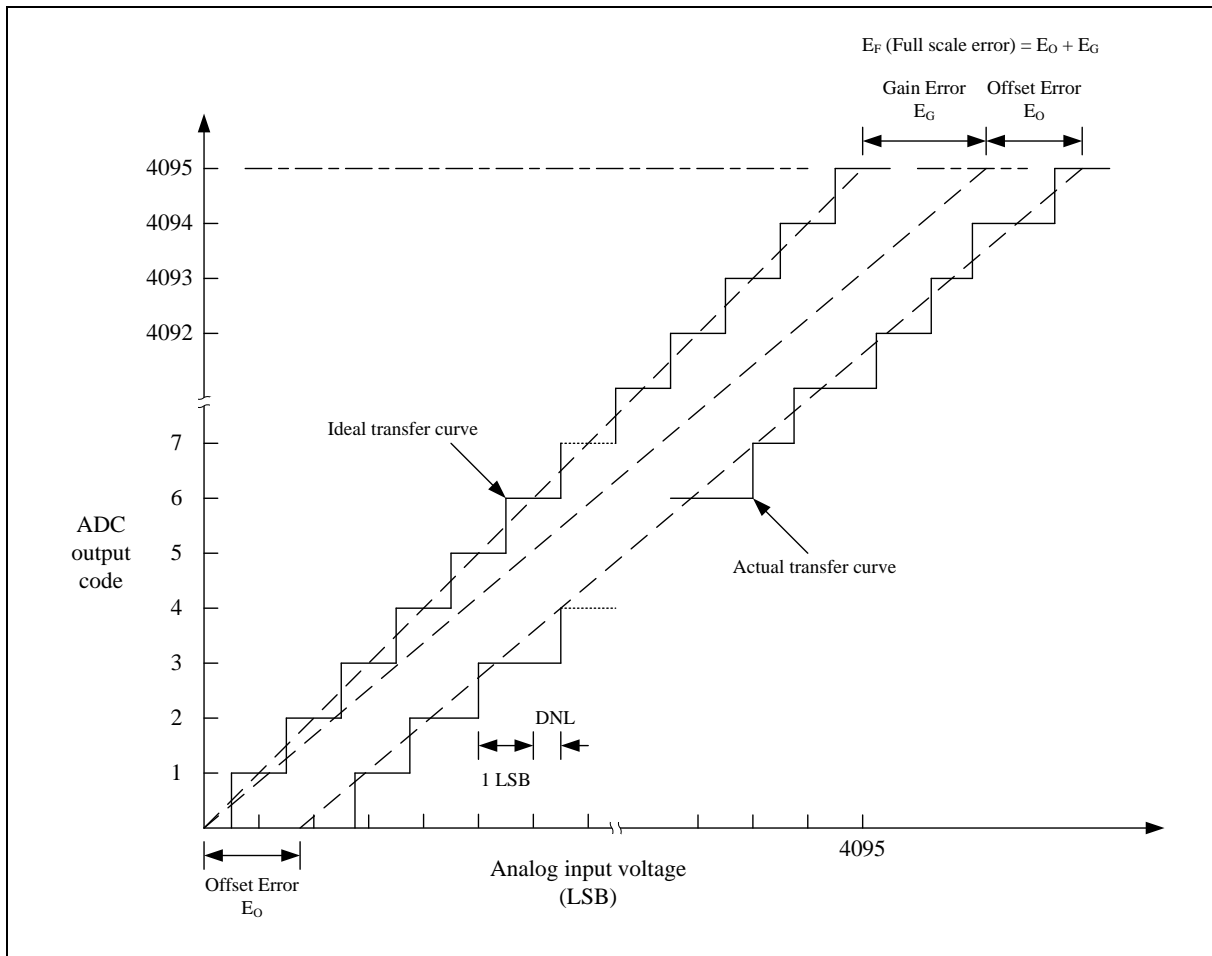

**Note:** The INL is the peak difference between the transition point of the steps of the calibrated transfer curve and the ideal transfer curve. A calibrated transfer curve means it has calibrated the offset and gain error from the actual transfer curve.

8.5.4 Analog Comparator Controller (ACMP)

The maximum values are obtained for  $V_{DD} = 5.5\text{ V}$  and maximum ambient temperature ( $T_A$ ), and the typical values for  $T_A = 25\text{ }^\circ\text{C}$  and  $V_{DD} = 3.3\text{ V}$  unless otherwise specified.

Symbol	Parameter	Min	Typ	Max	Unit	Test Conditions
$AV_{DD}$	Analog supply voltage	1.75	-	5.5	V	$V_{DD} = AV_{DD}$
$T_A$	Temperature	-40	-	105	$^\circ\text{C}$	
$I_{ACMP}^{[2]}$	ACMP operating current	-	38	90	$\mu\text{A}$	MODESEL = 11
		-	10	30		MODESEL = 10
		-	3	10		MODESEL = 01
		-	1.2	6		MODESEL = 00
$V_{CM}^{[2]}$	Input common mode voltage range	0.1	$\frac{1}{2} AV_{DD}$	$AV_{DD} - 0.1$		
$V_{DI}^{[2]}$	Differential input voltage sensitivity	-	10	-	mV	Hysteresis disable (HYSSEL = 00)
$V_{offset}^{[2]}$	Input offset voltage	-	$\pm 10$	$\pm 20$	mV	Hysteresis disable (HYSSEL = 00)
$V_{hys}^{[2]}$	Hysteresis window	-	10	20	mV	HYSSEL = 01
		-	20	40		HYSSEL = 10
		-	30	60		HYSSEL = 11
$A_V^{[1]}$	DC voltage Gain	43	70	-	dB	
$T_d^{[2]}$	Propagation delay	-	175	250	nS	MODESEL = 11
		-	350	600		MODESEL = 10
		-	700	2000		MODESEL = 01
		-	1400	4500		MODESEL = 00
$T_{Setup}^{[2]}$	Setup time	-	$250 + T_d$	$450 + T_d$	$\mu\text{S}$	
$A_{CRV}^{[2]}$	CRV output voltage	-5	-	5	%	$AV_{DD} \times (1/6 + CRVCTL/24)$
$R_{CRV}^{[2]}$	Unit resistor value	-	4.7	-	k $\Omega$	
$I_{DD\_CRV}^{[2]}$	Operating current	-	30	120	$\mu\text{A}$	

Note:

1. Guaranteed by design, not tested in production.
2. Guaranteed by characteristic, not tested in production.

Table 8.5-3 ACMP Characteristics

### 8.5.5 Digital to Analog Converter (DAC)

The maximum values are obtained for  $V_{DD} = 5.5\text{ V}$  and maximum ambient temperature ( $T_A$ ), and the typical values for  $T_A = 25\text{ }^\circ\text{C}$  and  $V_{DD} = 3.3\text{ V}$  unless otherwise specified.

Symbol	Parameter	Min	Typ	Max	Unit	Test Condition
$V_{DD}$	Analog supply voltage	2.5	-	5.5	V	-
$N_R$	Resolution	12			bit	-
$V_{REF}$	Reference supply voltage	1.65	-	$V_{DD}$	V	$V_{REF} \leq V_{DD}$
$DNL^{[2]}$	Differential non-linearity error	-	-	$\pm 1$	LSB	12-bit mode
		-	-	$\pm 0.5$	LSB	8-bit mode
$INL^{[2]}$	Integral non-linearity error	-	-	$\pm 2$	LSB	12-bit mode
		-	-	$\pm 0.5$	LSB	8-bit mode
$OE^{[2]}$	Offset Error	-	-	$\pm 25$	LSB	12-bit mode DACOUT buffer ON
		-	-	$\pm 5$	LSB	12-bit mode DACOUT buffer OFF
		-	-	$\pm 2$	LSB	8-bit mode
$GE^{[2]}$	Gain Error	-	-	$\pm 20$	LSB	12-bit mode DACOUT buffer ON
		-	-	$\pm 4$	LSB	12-bit mode DACOUT buffer OFF
		-	-	$\pm 2$	LSB	8-bit mode
$AE^{[2]}$	Absolute Error	-	-	$\pm 8$	LSB	12-bit mode DACOUT buffer ON
		-	-	$\pm 4$	LSB	12-bit mode DACOUT buffer OFF
		-	-	$\pm 2$	LSB	8-bit mode
-	Monotonic	10-bit guaranteed			-	-
$V_O^{[1]}$	Output Voltage	0.2	-	$V_{DD} - 0.2$	V	DACOUT buffer ON
		1*LSB	-	$V_{REF} - 1*LSB$	V	DACOUT buffer OFF
$R_{LOAD}^{[2][3]}$	Resistive load	5	-	-	k $\Omega$	DACOUT buffer ON
$R_O^{[2]}$	Output impedance	-	8	20	k $\Omega$	DACOUT buffer OFF
$C_{LOAD}^{[2][4]}$	Capacitive load	-	-	50	pF	-
$I_{DAC\_AVDD}^{[2]}$	DAC operating current on $V_{DD}$ supply	-	340	550	$\mu\text{A}$	$V_{DD} = 5.5\text{V}$ , no load, lowest code (0x000)

						$AV_{DD} = 5.5V$ , no load, middle code (0x800)
$I_{DAC\_VREF}^{[2]}$	DAC operating current on $V_{REF}$ supply	-	-	280	$\mu A$	$V_{REF} = 5.5V$ , no load, middle code (0x800)
$T_B^{[2]}$	Settling Time	-	3	4	$\mu S$	Full scale: for a 12-bit input code transition between the lowest and the highest input codes when DAC_OUT reaches final value $\pm 1$ LSB, $C_{LOAD} \leq 50pF$ , $R_{LOAD} \geq 5k\Omega$
$F_S$	Update Rate	-	-	1	$M_{SPS}$	Max. frequency for a correct DAC_OUT change from core $i$ to $i+1$ LSB, $C_{LOAD} \leq 50pF$ , $R_{LOAD} \geq 5k\Omega$
$T_{WAKEUP}$	Wake-up Time	-	9	15	$\mu S$	Wakeup time from OFF state. Input code between lowest and highest possible codes. DAC clock source = 1MHz
$PSRR^{[1]}$	Power Supply Rejection Ratio	-	-60	-40	dB	No $R_{LOAD}$ , $C_{LOAD} = 50pF$
<b>Note:</b> <ol style="list-style-type: none"> <li>1. Guaranteed by design, not tested in production</li> <li>2. Guaranteed by characteristic, not tested in production.</li> <li>3. Resistive load between DACOUT and <math>AV_{SS}</math>.</li> <li>4. Capacitive load at DACOUT pin.</li> </ol>						

Table 8.5-4 DAC Characteristics

### 8.5.6 OP Amplifier (OPA)

The maximum values are obtained for  $V_{DD} = 5.5\text{ V}$  and maximum ambient temperature ( $T_A$ ), and the typical values for  $T_A = 25\text{ °C}$  and  $V_{DD} = 3.3\text{ V}$  unless otherwise specified.

Symbol	Parameter	Min	Typ	Max	Unit	Test Condition
$AV_{DD}$	Analog supply voltage	2.5	-	5.5	V	
$T_A$	Temperature	-40	-	105	°C	
$I_{OPA}$	OPA operating current	-	500	1400	μA	
$V_{CM}^{[2]}$	Common mode input range	0.1	-	$AV_{DD}-0.1$	V	
$V_{OS}^{[2]}$	Output Saturation Voltage	0.1	-	$AV_{DD}-0.1$	V	$R_{LOAD} = 4\text{ K}\Omega$
$V_{OFFSETO}^{[2]}$	Input offset voltage	-	$\pm 1$	$\pm 3$	mV	After Offset voltage calibration $V_{CM}=AV_{DD}/2$
		-	$\pm 1$	$\pm 5$	mV	After Offset voltage calibration $V_{CM}=0.1 \sim AV_{DD} - 0.1$
$CMRR^{[1]}$	Common Mode Rejection Ratio	-	89	-	dB	$AV_{DD}=3.3V, V_{CM}=AV_{DD}/2$
$PSRR^{[1]}$	Power Supply Rejection Ratio	-	120	-	dB	$AV_{DD}=3.3V, V_{CM}=AV_{DD}/2$
$GBW^{[2]}$	Bandwidth	-	5	-	MHz	$AV_{DD}=3.3V, V_{CM}=AV_{DD}/2$
$SR^{[2]}$	Slew rate	-	7.5	-	V/μS	$R_{LOAD} = 4\text{ K}\Omega, C_{LOAD} = 50pF$
$AO^{[1]}$	Open loop gain	-	91	-	dB	
$PM^{[1]}$	Phase Margin	-	63	-	degree	$AV_{DD}=3.3V, V_{CM}=AV_{DD}/2$
$GM^{[1]}$	Gain Margin	-	TBD	-	dB	
$T_{WAKEUP}^{[2]}$	Wake up time from disable state	-	2	20	μS	
$R_{LOAD}^{[2]}$	Resistive load	4	-	-	kΩ	
$C_{LOAD}^{[2]}$	Capacitive load	-	-	50	pF	
<b>Note:</b>						
1. Guaranteed by design, not tested in production						
2. Guaranteed by characteristic, not tested in production.						

Table 8.5-5 OPA Characteristics

8.5.7 Internal Voltage Reference

The maximum values are obtained for  $V_{DD} = 5.5\text{ V}$  and maximum ambient temperature ( $T_A$ ), and the typical values for  $T_A = 25\text{ }^\circ\text{C}$  and  $V_{DD} = 3.3\text{ V}$  unless otherwise specified.

Symbol	Parameter	Min	Typ	Max	Unit	Test Condition
$V_{REF\_INT}$	Internal reference voltage	1.49	1.536	1.59	V	$AV_{DD} \geq 2.0\text{ V}$
		1.98	2.048	2.11		$AV_{DD} \geq 2.4\text{ V}$
		2.48	2.560	2.64		$AV_{DD} \geq 2.9\text{ V}$
		2.97	3.072	3.17		$AV_{DD} \geq 3.4\text{ V}$
		3.97	4.096	4.22		$AV_{DD} \geq 4.5\text{ V}$
$T_s^{[*1]}$	Stable time	-	0.5	0.8	mS	$C_L = 4.7\text{ }\mu\text{F}$ , $V_{REF}$ initial=0V, Preload is enabled.
		-	9.3	13	mS	$C_L = 4.7\text{ }\mu\text{F}$ , $V_{REF}$ initial=5.5V, Preload is enabled.
		-	24	180	$\mu\text{S}$	$C_L = 1\text{ }\mu\text{F}$ , $V_{REF}$ initial=0V, Preload is enabled.
		-	2	2.6	mS	$C_L = 1\text{ }\mu\text{F}$ , $V_{REF}$ initial=5.5V, Preload is enabled.
$I_{VREF\_INT}^{[*1]}$	Internal $V_{REF}$ Operating curren	-	-	1	mA	

**Note:**

- Guaranteed by characterization, not tested in production.

Table 8.5-6 Internal Voltage Reference Characteristics

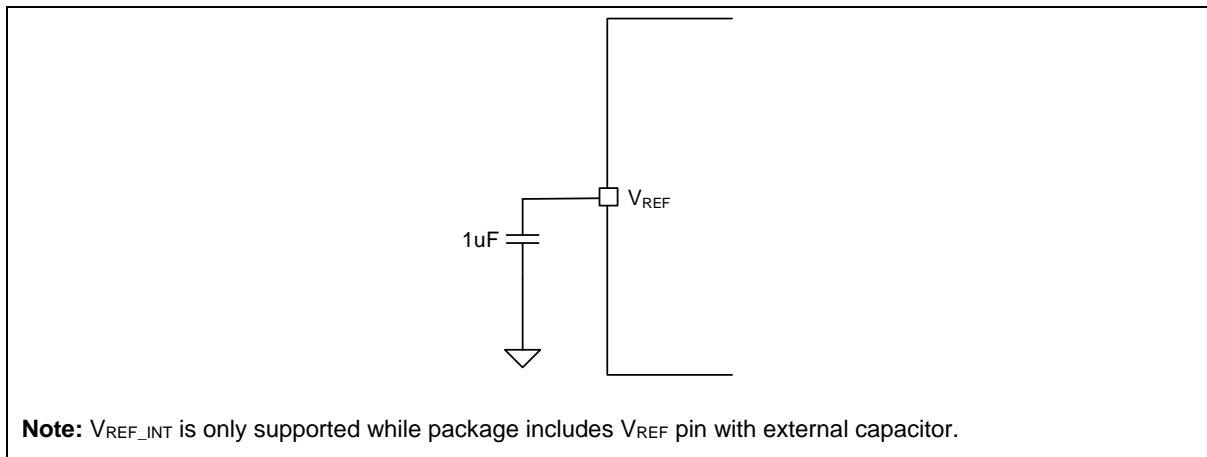

Figure 8.5-2 Typical Connection with Internal Voltage Reference

**8.5.8 Temperature Sensor**

The maximum values are obtained for  $V_{DD} = 5.5\text{ V}$  and maximum ambient temperature ( $T_A$ ), and the typical values for  $T_A = 25\text{ }^\circ\text{C}$  and  $V_{DD} = 3.3\text{ V}$  unless otherwise specified.

Symbol	Parameter	Min	Typ	Max	Unit	Test Condition
$V_{TEMP\_OS}^{[1]}$	Temperature sensor offset voltage	690	720	750	mV	$T_A = 0^\circ\text{C}$
$T_C^{[1]}$	Temperature Coefficient	-1.74	-1.83	-1.9	mV/ $^\circ\text{C}$	
$I_{TEMP}^{[1]}$	Operating current	-	16	30	$\mu\text{A}$	

**Note:**

1. Guaranteed by characterization, not tested in production
2. Guaranteed by design, not tested in production
3.  $V_{TEMP} \text{ (mV)} = T_C \text{ (mV}/^\circ\text{C)} \times \text{Temperature } (^\circ\text{C)} + V_{TEMP\_OS} \text{ (mV)}$

Table 8.5-7 Temperature Sensor Characteristics

### 8.6 Communications Characteristics

#### 8.6.1 SPI Dynamic Characteristics

Symbol	Parameter	Specificaitons <sup>[1]</sup>				Test Conditions
		Min	Typ	Max	Unit	
F <sub>SPICLK</sub> 1/T <sub>SPICLK</sub>	SPI clock frequency	-	-	24	MHz	4.5 V ≤ V <sub>DD</sub> ≤ 5.5 V, C <sub>L</sub> = 30 pF
		-	-	24		2.7 V ≤ V <sub>DD</sub> ≤ 5.5 V, C <sub>L</sub> = 30 pF
		-	-	16		1.8 V ≤ V <sub>DD</sub> ≤ 5.5 V, C <sub>L</sub> = 30 pF
t <sub>CLKH</sub>	Clock output High time	T <sub>SPICLK</sub> / 2			nS	
t <sub>CLKL</sub>	Clock output Low time	T <sub>SPICLK</sub> / 2			nS	
t <sub>DS</sub>	Data input setup time	2	-	-	nS	
t <sub>DH</sub>	Data input hold time	4	-	-	nS	
t <sub>V</sub>	Data output valid time	-	-	4.5	nS	4.5 V ≤ V <sub>DD</sub> ≤ 5.5 V, C <sub>L</sub> = 30 pF
		-	-	4.5	nS	2.7 V ≤ V <sub>DD</sub> ≤ 5.5 V, C <sub>L</sub> = 30 pF
		-	-	4.5	nS	1.8 V ≤ V <sub>DD</sub> ≤ 5.5 V, C <sub>L</sub> = 30 pF

**Note:**  
1. Guaranteed by design.

Table 8.6-1 SPI Master Mode Characteristics

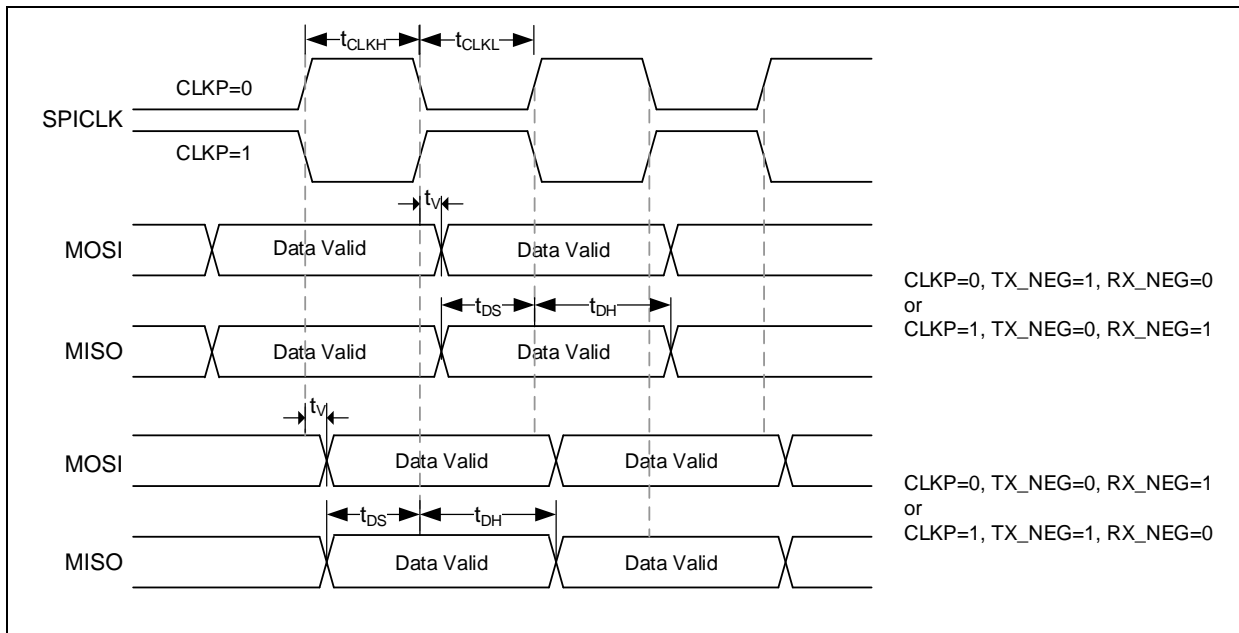

Figure 8.6-1 SPI Master Mode Timing Diagram

Symbol	Parameter	Specificaitons <sup>1</sup>				Test Conditions
		Min	Typ	Max	Unit	
F <sub>SPICLK</sub> 1/T <sub>SPICLK</sub>	SPI clock frequency	-	-	11.2	MHz	4.5 V ≤ V <sub>DD</sub> ≤ 5.5 V, CL = 30 pF
		-	-	8.8		2.7 V ≤ V <sub>DD</sub> ≤ 5.5 V, CL = 30 pF
		-	-	4.6		1.8 V ≤ V <sub>DD</sub> ≤ 5.5 V, CL = 30 pF
t <sub>CLKH</sub>	Clock output High time	T <sub>SPICLK</sub> / 2			nS	
t <sub>CLKL</sub>	Clock output Low time	T <sub>SPICLK</sub> / 2			nS	
t <sub>SS</sub>	Slave select setup time	1 T <sub>SPICLK</sub> + 2ns	-	-	nS	4.5 V ≤ V <sub>DD</sub> ≤ 5.5 V, CL = 30 pF
		1 T <sub>SPICLK</sub> + 2ns	-	-		2.7 V ≤ V <sub>DD</sub> ≤ 5.5 V, CL = 30 pF
		1 T <sub>SPICLK</sub> + 3ns	-	-		1.8 V ≤ V <sub>DD</sub> ≤ 5.5 V, CL = 30 pF
t <sub>SH</sub>	Slave select hold time	1 T <sub>SPICLK</sub>	-	-	nS	
t <sub>DS</sub>	Data input setup time	1.5	-	-	nS	
t <sub>DH</sub>	Data input hold time	3.5	-	-	nS	
t <sub>v</sub>	Data output valid time	-	-	35	nS	4.5 V ≤ V <sub>DD</sub> ≤ 5.5 V, CL = 30 pF
		-	-	42		2.7 V ≤ V <sub>DD</sub> ≤ 5.5 V, CL = 30 pF
		-	-	74		1.8 V ≤ V <sub>DD</sub> ≤ 5.5 V, CL = 30 pF
<b>Note:</b> 1. Guaranteed by design.						

Table 8.6-2 SPI Slave Mode Characteristics

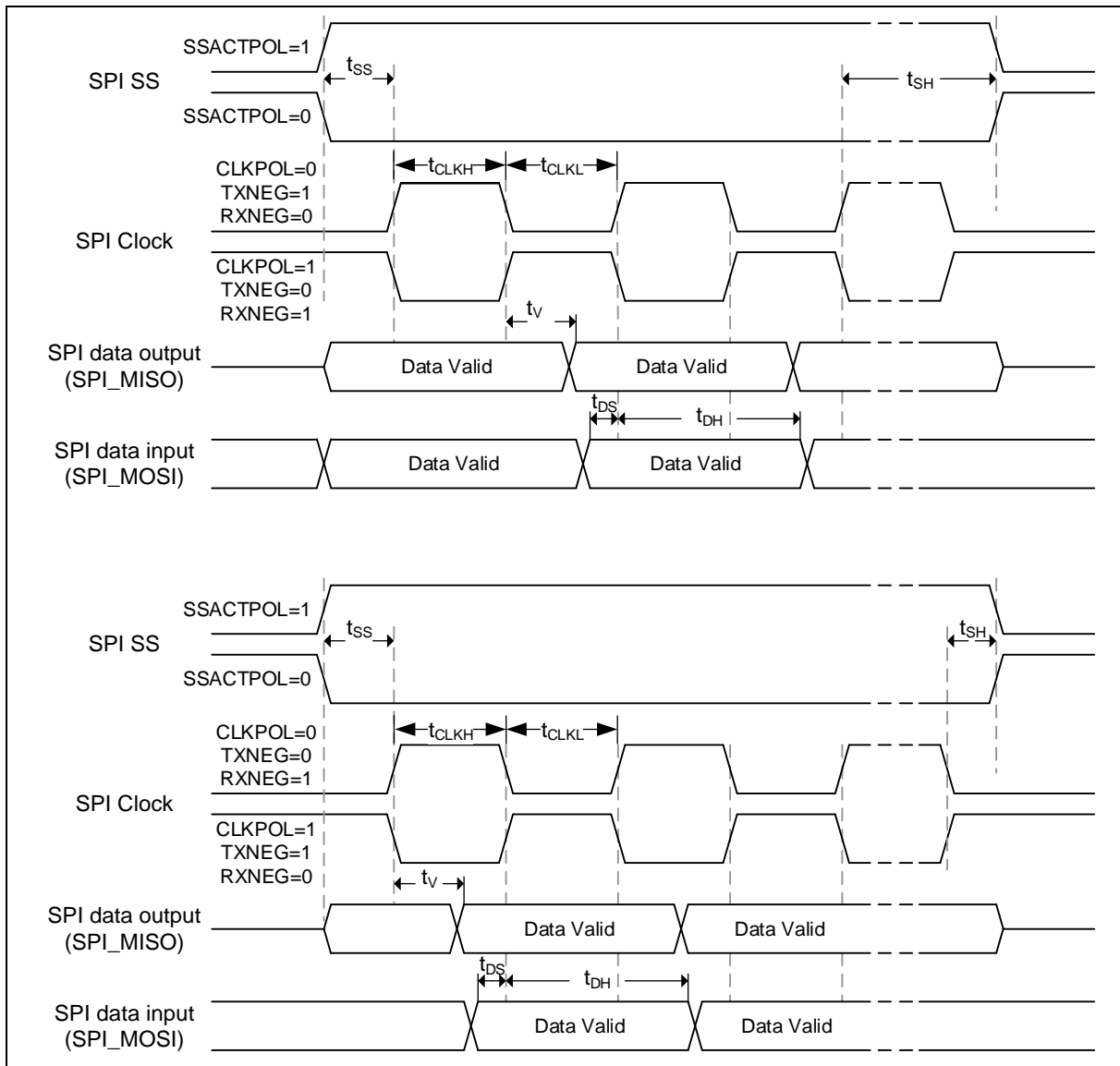

Figure 8.6-2 SPI Slave Mode Timing Diagram

8.6.2 SPI - I<sup>2</sup>S Dynamic Characteristics

Symbol	Parameter	Min [ <sup>1</sup> ]	Max [ <sup>1</sup> ]	Unit	Test Conditions
$t_w(\text{CKH})$	I <sup>2</sup> S clock high time	80	-	nS	Master $f_{\text{PCLK}} = 48 \text{ MHz}$ , data: 24 bits, audio frequency = 128 kHz
$t_w(\text{CKL})$	I <sup>2</sup> S clock low time	80	-		
$t_v(\text{WS})$	WS valid time	2	6		
$t_h(\text{WS})$	WS hold time	2	-		
$t_{\text{su}}(\text{WS})$	WS setup time	24	-		
$t_h(\text{WS})$	WS hold time	0	-		
$\text{DuCy}(\text{SCK})$	I <sup>2</sup> S slave input clock duty cycle	30	70		
$t_{\text{su}}(\text{SD\_MR})$	Data input setup time	10	-	nS	Master receiver
$t_{\text{su}}(\text{SD\_SR})$		7	-		Slave receiver
$t_h(\text{SD\_MR})$	Data input hold time	7	-		Master receiver
$t_h(\text{SD\_SR})$		4	-		Slave receiver
$t_v(\text{SD\_ST})$	Data output valid time	-	25		Slave transmitter (after enable edge)
$t_h(\text{SD\_ST})$	Data output hold time	4	-		Slave transmitter (after enable edge)
$t_v(\text{SD\_MT})$	Data output valid time	-	4		Master transmitter (after enable edge)
$t_h(\text{SD\_MT})$	Data output hold time	0	-		Master transmitter (after enable edge)
<b>Note:</b>					
1. Guaranteed by design.					

Table 8.6-3 I<sup>2</sup>S Characteristics

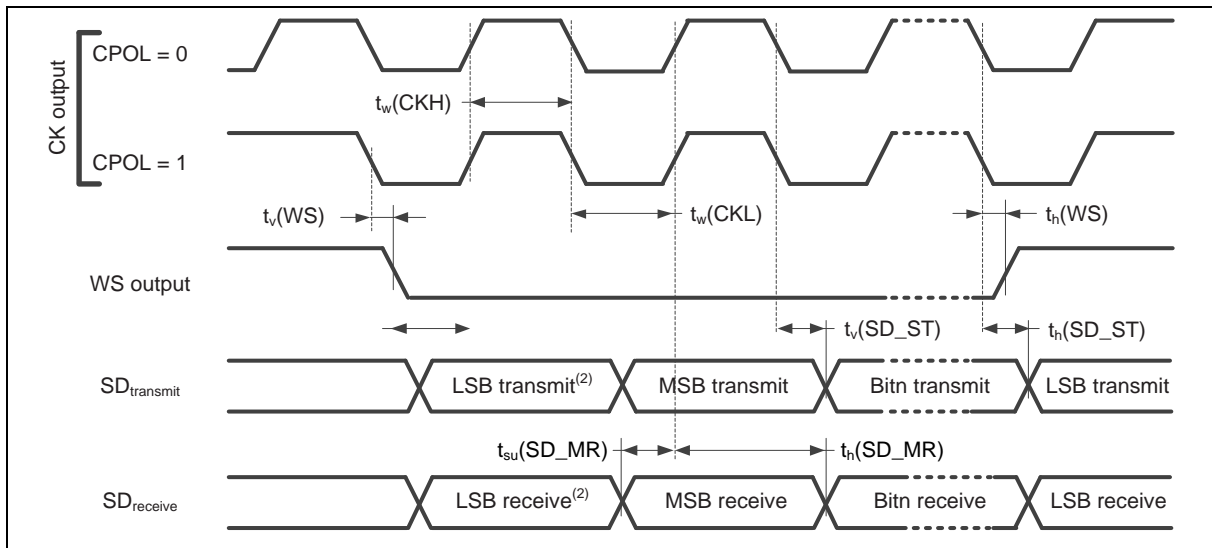

Figure 8.6-3 I<sup>2</sup>S Master Mode Timing Diagram

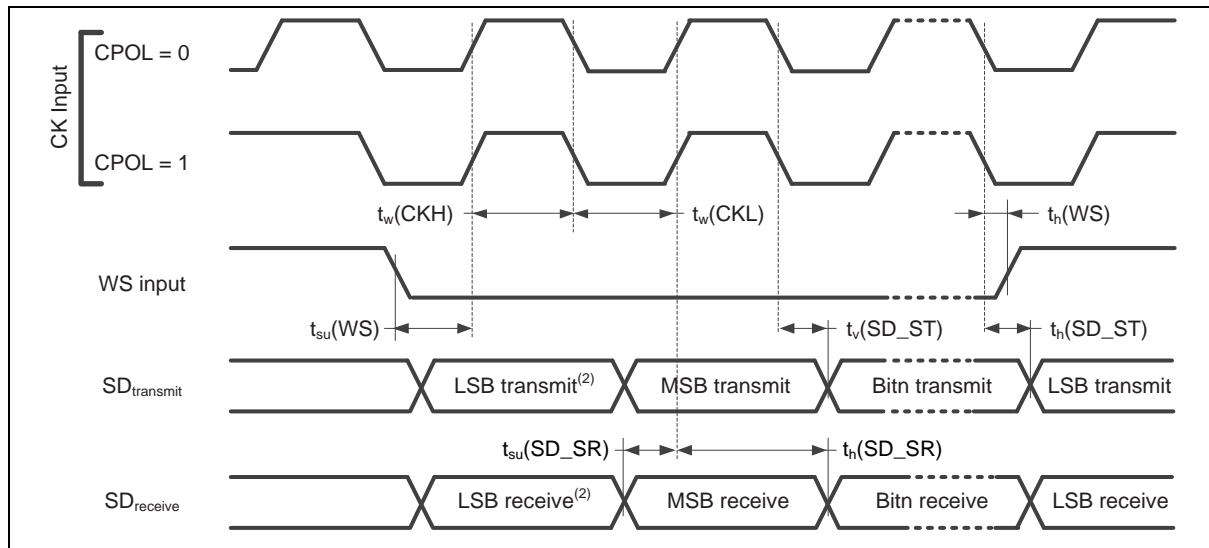

Figure 8.6-4 I<sup>2</sup>S Slave Mode Timing Diagram

8.6.3 I<sup>2</sup>C Dynamic Characteristics

Symbol	Parameter	Standard Mode <sup>[1][2]</sup>		Fast Mode <sup>[1][2]</sup>		Unit
		Min	Max	Min	Max	
t <sub>LOW</sub>	SCL low period	4.7	-	1.3	-	μS
t <sub>HIGH</sub>	SCL high period	4	-	0.6	-	μS
t <sub>SU, STA</sub>	Repeated START condition setup time	4.7	-	0.6	-	μS
t <sub>HD, STA</sub>	START condition hold time	4	-	0.6	-	μS
t <sub>SU, STO</sub>	STOP condition setup time	4	-	0.6	-	μS
t <sub>BUF</sub>	Bus free time	4.7 <sup>[3]</sup>	-	1.2 <sup>[3]</sup>	-	μS
t <sub>SU, DAT</sub>	Data setup time	250	-	100	-	nS
t <sub>HD, DAT</sub>	Data hold time	0 <sup>[4]</sup>	3.45 <sup>[5]</sup>	0 <sup>[4]</sup>	0.8 <sup>[5]</sup>	μS
t <sub>r</sub>	SCL/SDA rise time	-	1000	20+0.1C <sub>b</sub>	300	nS
t <sub>f</sub>	SCL/SDA fall time	-	300	-	300	nS
C <sub>b</sub>	Capacitive load for each bus line	-	400	-	400	pF

Note:

1. Guaranteed by characteristic, not tested in production
2. HCLK must be higher than 2 MHz to achieve the maximum standard mode I2C frequency. It must be higher than 8 MHz to achieve the maximum fast mode I2C frequency.
3. I<sup>2</sup>C controller must be retriggered immediately at slave mode after receiving STOP condition.
4. The device must internally provide a hold time of at least 300 ns for the SDA signal in order to bridge the undefined region of the falling edge of SCL.
5. The maximum hold time of the Start condition has only to be met if the interface does not stretch the low period of SCL signal.

Table 8.6-4 I<sup>2</sup>C Characteristics

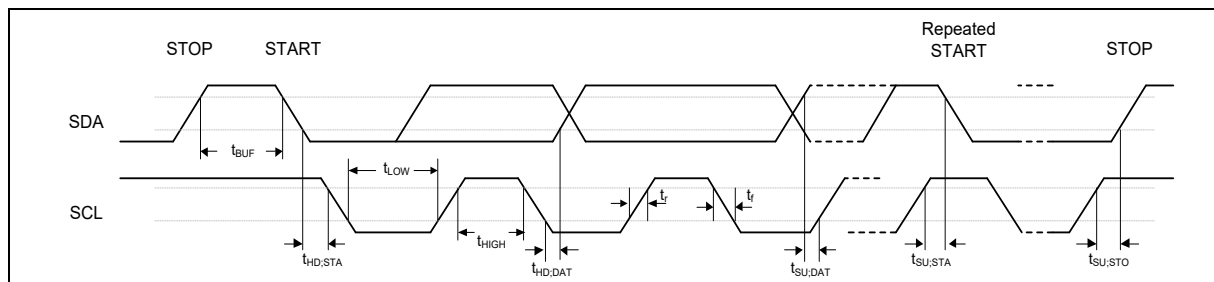

Figure 8.6-5 I<sup>2</sup>C Timing Diagram

8.6.4 USCI - SPI Dynamic Characteristics

Symbol	Parameter	Min <sup>[1]</sup>	Typ	Max <sup>[1]</sup>	Unit	Test Conditions
F <sub>SPICLK</sub> 1/T <sub>SPICLK</sub>	SPI clock frequency	-	-	24	MHz	4.5 V ≤ V <sub>DD</sub> ≤ 5.5 V, C <sub>L</sub> = 30 pF
		-	-	24		2.7 V ≤ V <sub>DD</sub> ≤ 5.5 V, C <sub>L</sub> = 30 pF
		-	-	16		1.8 V ≤ V <sub>DD</sub> ≤ 5.5 V, C <sub>L</sub> = 30 pF
t <sub>CLKH</sub>	Clock output High time	T <sub>SPICLK</sub> / 2			nS	
t <sub>CLKL</sub>	Clock output Low time	T <sub>SPICLK</sub> / 2			nS	
t <sub>DS</sub>	Data input setup time	2	-	-	nS	
t <sub>DH</sub>	Data input hold time	4	-	-	nS	
t <sub>V</sub>	Data output valid time	-	-	9	nS	4.5 V ≤ V <sub>DD</sub> ≤ 5.5 V, C <sub>L</sub> = 30 pF
		-	-	9	nS	2.7 V ≤ V <sub>DD</sub> ≤ 5.5 V, C <sub>L</sub> = 30 pF
		-	-	8.5	nS	1.8 V ≤ V <sub>DD</sub> ≤ 5.5 V, C <sub>L</sub> = 30 pF

**Note:**  
1. Guaranteed by design.

Table 8.6-5 USCI-SPI Master Mode Characteristics

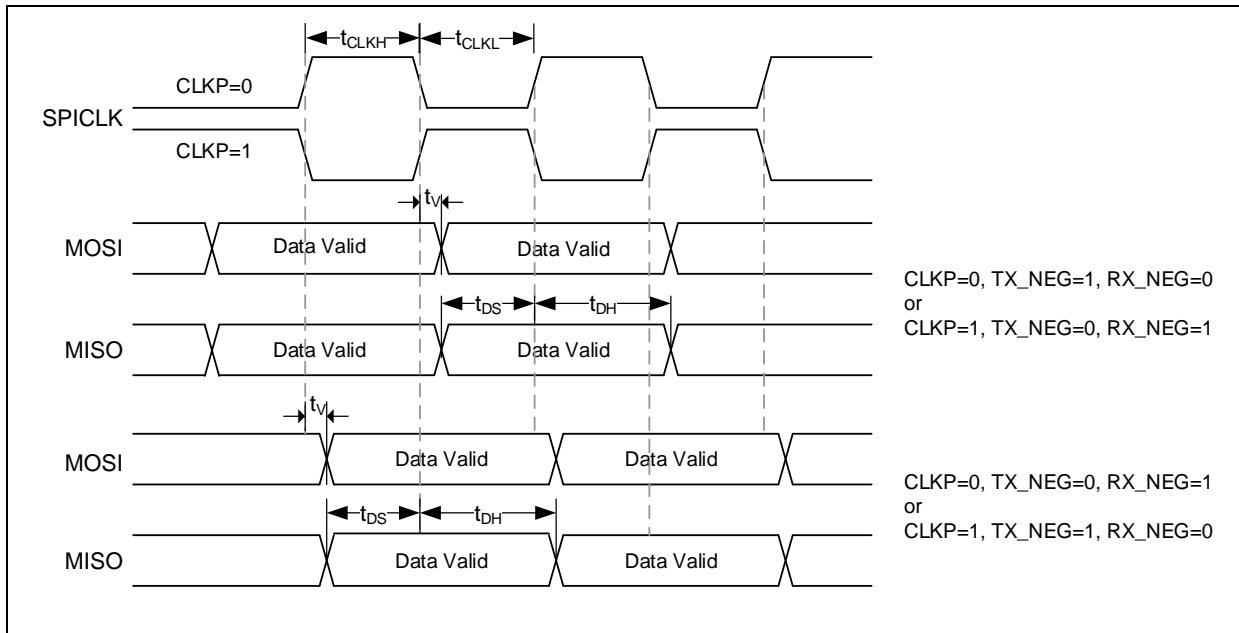

Figure 8.6-6 USCI-SPI Master Mode Timing Diagram

Symbol	Parameter	Min <sup>[1]</sup>	Typ	Max <sup>[1]</sup>	Unit	Test Conditions
F <sub>SPICLK</sub> 1/T <sub>SPICLK</sub>	SPI clock frequency	-	-	6.3	MHz	4.5 V ≤ V <sub>DD</sub> ≤ 5.5 V, C <sub>L</sub> = 30 pF
		-	-	5.6		2.7 V ≤ V <sub>DD</sub> ≤ 5.5 V, C <sub>L</sub> = 30 pF
		-	-	4.2		1.8 V ≤ V <sub>DD</sub> ≤ 5.5 V, C <sub>L</sub> = 30 pF
t <sub>CLKH</sub>	Clock output High time	T <sub>SPICLK</sub> / 2			nS	
t <sub>CLKL</sub>	Clock output Low time	T <sub>SPICLK</sub> / 2			nS	
t <sub>SS</sub>	Slave select setup time	1 T <sub>SPICLK</sub> + 2ns	-	-	nS	4.5 V ≤ V <sub>DD</sub> ≤ 5.5 V, C <sub>L</sub> = 30 pF
		1 T <sub>SPICLK</sub> + 2ns	-	-		2.7 V ≤ V <sub>DD</sub> ≤ 5.5 V, C <sub>L</sub> = 30 pF
		1 T <sub>SPICLK</sub> + 3ns	-	-		1.8 V ≤ V <sub>DD</sub> ≤ 5.5 V, C <sub>L</sub> = 30 pF
t <sub>SH</sub>	Slave select hold time	1 T <sub>SPICLK</sub>	-	-	nS	
t <sub>DS</sub>	Data input setup time	2	-	-	nS	
t <sub>DH</sub>	Data input hold time	4	-	-	nS	
t <sub>v</sub>	Data output valid time	-	-	79	nS	4.5 V ≤ V <sub>DD</sub> ≤ 5.5 V, C <sub>L</sub> = 30 pF
		-	-	88		2.7 V ≤ V <sub>DD</sub> ≤ 5.5 V, C <sub>L</sub> = 30 pF
		-	-	117		1.8 V ≤ V <sub>DD</sub> ≤ 5.5 V, C <sub>L</sub> = 30 pF
<b>Note:</b>						
1. Guaranteed by design.						

Table 8.6-6 USCI-SPI Slave Mode Characteristics

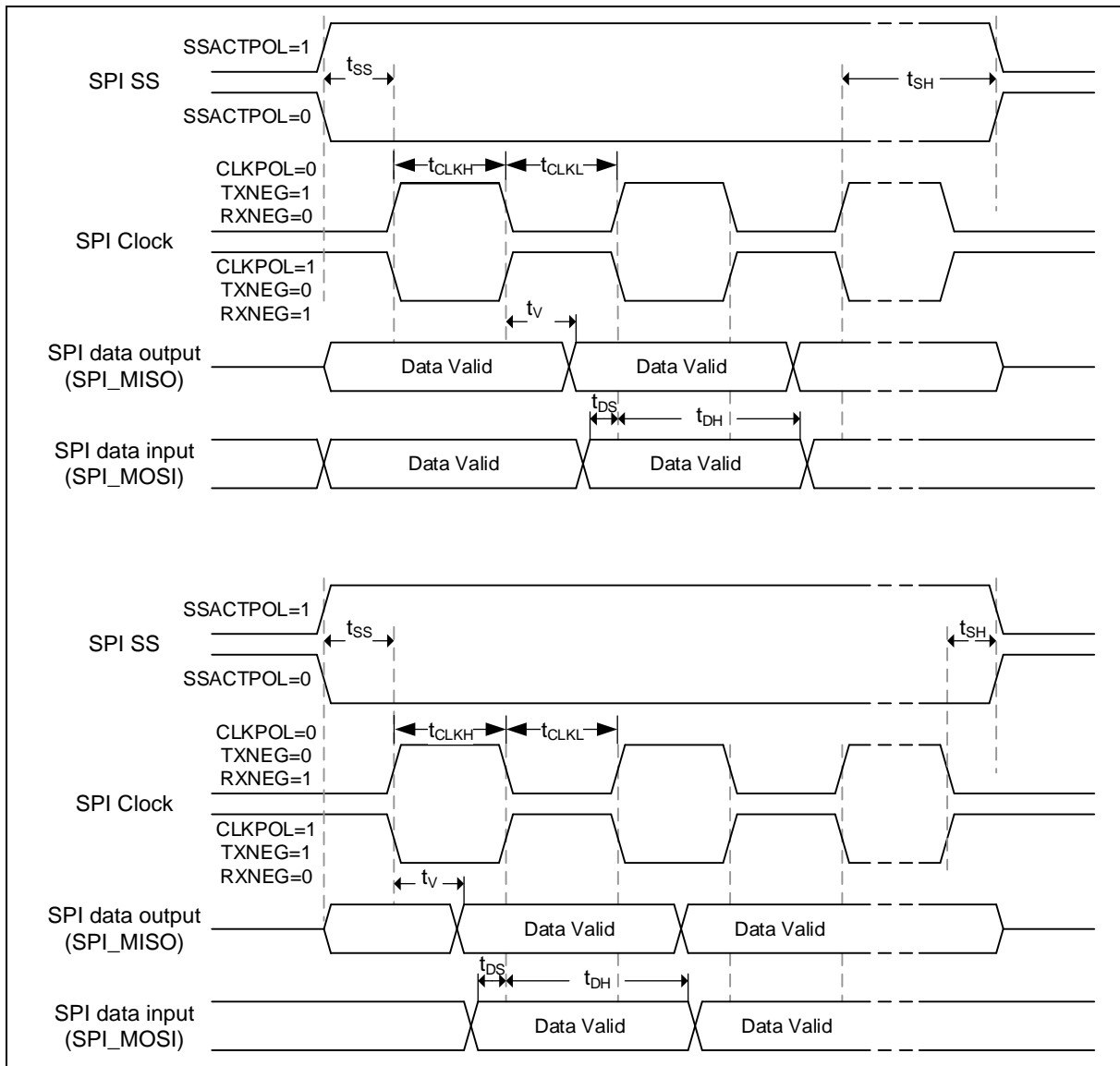

Figure 8.6-7 USCI-SPI Slave Mode Timing Diagram

8.6.5 USCI-I<sup>2</sup>C Dynamic Characteristics

Symbol	Parameter	Standard Mode <sup>[1][2]</sup>		Fast Mode <sup>[1][2]</sup>		Unit
		Min	Max	Min	Max	
t <sub>LOW</sub>	SCL low period	4.7	-	1.3	-	μS
t <sub>HIGH</sub>	SCL high period	4	-	0.6	-	μS
t <sub>SU, STA</sub>	Repeated START condition setup time	4.7	-	0.6	-	μS
t <sub>HD, STA</sub>	START condition hold time	4	-	0.6	-	μS
t <sub>SU, STO</sub>	STOP condition setup time	4	-	0.6	-	μS
t <sub>BUF</sub>	Bus free time	4.7 <sup>[3]</sup>	-	1.2 <sup>[3]</sup>	-	μS
t <sub>SU, DAT</sub>	Data setup time	250	-	100	-	nS
t <sub>HD, DAT</sub>	Data hold time	0 <sup>[4]</sup>	3.45 <sup>[5]</sup>	0 <sup>[4]</sup>	0.8 <sup>[5]</sup>	μS
t <sub>r</sub>	SCL/SDA rise time	-	1000	20+0.1C <sub>b</sub>	300	nS
t <sub>f</sub>	SCL/SDA fall time	-	300	-	300	nS
C <sub>b</sub>	Capacitive load for each bus line	-	400	-	400	pF

Note:

1. Guaranteed by characteristic, not tested in production
2. HCLK must be higher than 2 MHz to achieve the maximum standard mode I2C frequency. It must be higher than 8 MHz to achieve the maximum fast mode I2C frequency.
3. I2C controller must be retriggered immediately at slave mode after receiving STOP condition.
4. The device must internally provide a hold time of at least 300 ns for the SDA signal in order to bridge the undefined region of the falling edge of SCL.
5. The maximum hold time of the Start condition has only to be met if the interface does not stretch the low period of SCL signal.

Table 8.6-7 USCI-I<sup>2</sup>C Characteristics

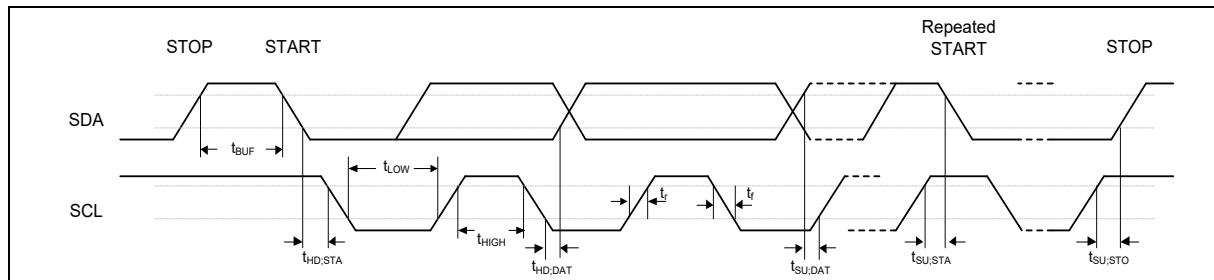

Figure 8.6-8 USCI-I<sup>2</sup>C Timing Diagram

### 8.6.6 USB Characteristics

#### 8.6.6.1 USB Full-Speed Characteristics

Symbol	Parameter	Min <sup>[1]</sup>	Typ	Max <sup>[1]</sup>	Unit	Test Conditions
V <sub>BUS</sub>	USB full speed transceiver operating voltage	4.4	-	5.25	V	-
V <sub>DD33</sub> <sup>[2]</sup>	USB Internal power regulator output	3.0	3.3	3.6	V	-
V <sub>IH</sub>	Input high (driven)	2.0	-	-	V	-
V <sub>IL</sub>	Input low	-	-	0.8	V	-
V <sub>DI</sub>	Differential input sensitivity	0.2	-	-	V	(USB_D+) - (USB_D-)
V <sub>CM</sub>	Differential common-mode range	0.8	-	2.5	V	Includes V <sub>DI</sub> range
V <sub>SE</sub>	Single-ended receiver threshold	0.8	-	2.0	V	-
	Receiver hysteresis	-	200	-	mV	-
V <sub>OL</sub>	Output low (driven)	0	-	0.3	V	-
V <sub>OH</sub>	Output high (driven)	2.8	-	3.6	V	-
V <sub>CRS</sub>	Output signal cross voltage	1.3	-	2.0	V	-
R <sub>PU</sub>	Pull-up resistor	1.19	-	1.9	kΩ	-
V <sub>TRM</sub>	Termination voltage for upstream port pull-up (RPU)	3.0	-	3.6	V	-
Z <sub>DRV</sub> <sup>[3]</sup>	Driver output resistance	-	10	-	Ω	Steady state drive
C <sub>IN</sub>	Transceiver capacitance	-	-	26	pF	Pin to GND

**Note:**

1. Guaranteed by characterization result, not tested in production.
2. To ensure stability, an external 1 μF output capacitor, 1uF external capacitor must be connected between the USB\_VDD33\_CAP pin and the closest GND pin of the device.
3. USB\_D+ and USB\_D- must be connected with external series resistors to fit USB Full-speed spec request (28 ~ 44Ω).

Table 8.6-8 USB Full-Speed Characteristics

#### 8.6.6.2 USB Full-Speed PHY Characteristics

Symbol	Parameter	Min <sup>[1]</sup>	Typ	Max <sup>[1]</sup>	Unit	Test Conditions
T <sub>FR</sub>	rise time	4	-	20	nS	C <sub>L</sub> =50 pF
T <sub>FF</sub>	fall time	4	-	20	nS	C <sub>L</sub> =50 pF
T <sub>FRFF</sub>	rise and fall time matching	90	-	111.11	%	T <sub>FRFF</sub> = T <sub>FR</sub> /T <sub>FF</sub>

**Note:**

1. Guaranteed by characterization result, not tested in production.

Table 8.6-9 USB Full-Speed PHY Characteristics

### 8.7 Flash DC Electrical Characteristics

The devices are shipped to customers with the Flash memory erased.

Symbol	Parameter	Min	Typ	Max	Unit	Test Condition
V <sub>FLA</sub> <sup>[1]</sup>	Supply voltage	-	1.5	-	V	T <sub>A</sub> = 25°C
T <sub>ERASE</sub>	Page erase time	-	4.2	-	mS	
T <sub>PROG</sub>	Program time	-	42	-	μS	
I <sub>DD1</sub>	Read current	-	3.15	-	mA	
I <sub>DD2</sub>	Program current	-	3.5	-	mA	
I <sub>DD3</sub>	Erase current	-	2	-	mA	
N <sub>ENDUR</sub>	Endurance	20,000	-	-	cycles <sup>[2]</sup>	
T <sub>RET</sub>	Data retention	10	-	-	year	20 kcycle <sup>[3]</sup> T <sub>J</sub> = 125°C
		20	-	-	year	20 kcycle <sup>[3]</sup> T <sub>J</sub> = 105°C

**Note:**

- V<sub>FLA</sub> is source from chip internal LDO output voltage.
- Number of program/erase cycles.
- Guaranteed by design.
- The Erase/program command are only supported at power level 0.

Table 8.7-1 Flash Characteristics

### 9 PACKAGE DIMENSIONS

Package is Halogen-free, RoHS-compliant and TSCA-compliant.

#### 9.1 TSSOP20 (4.4x6.5x0.9 mm<sup>3</sup>)

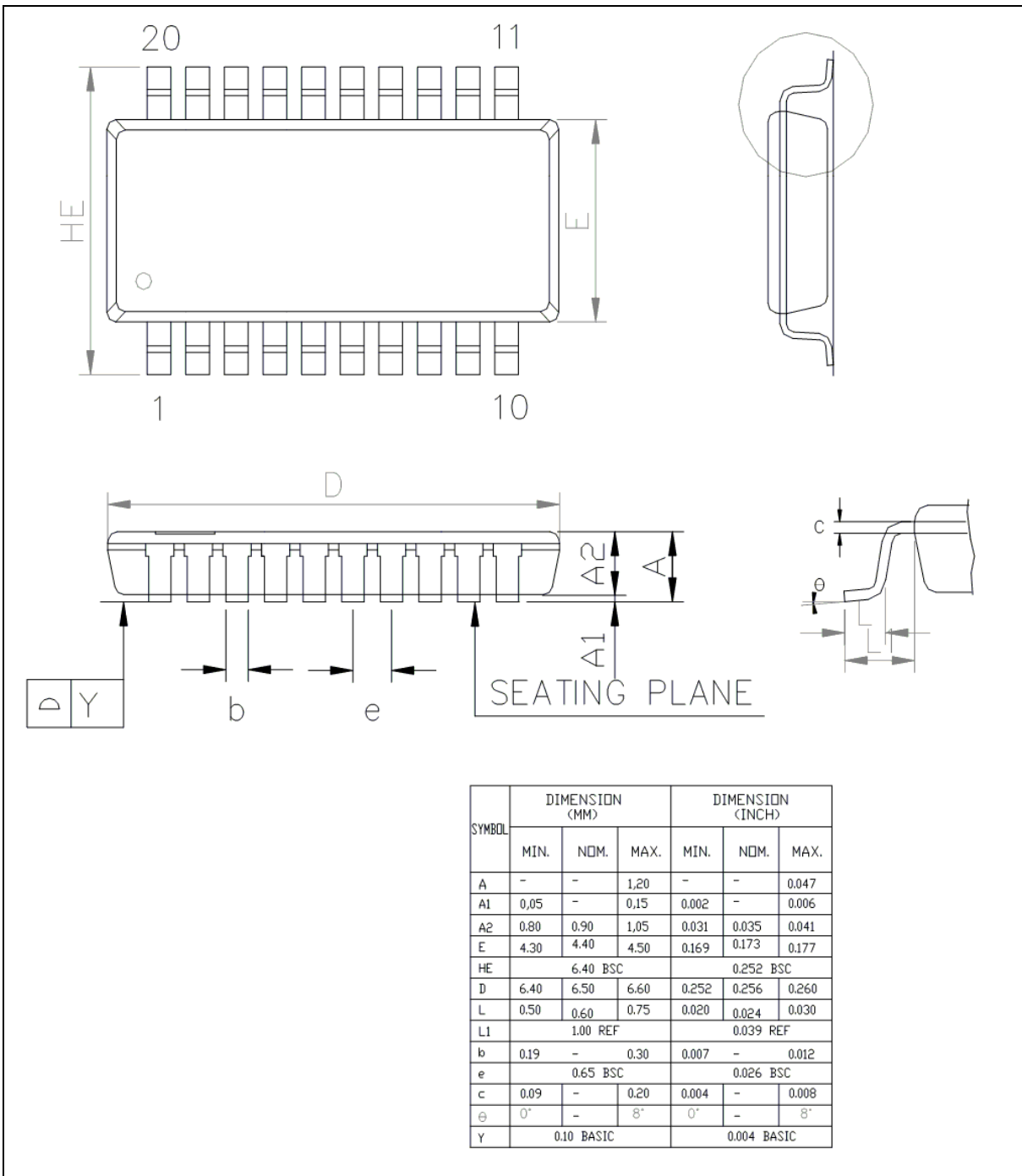

9.2 TSSOP28 (4.4x9.7x1.0 mm<sup>3</sup>)

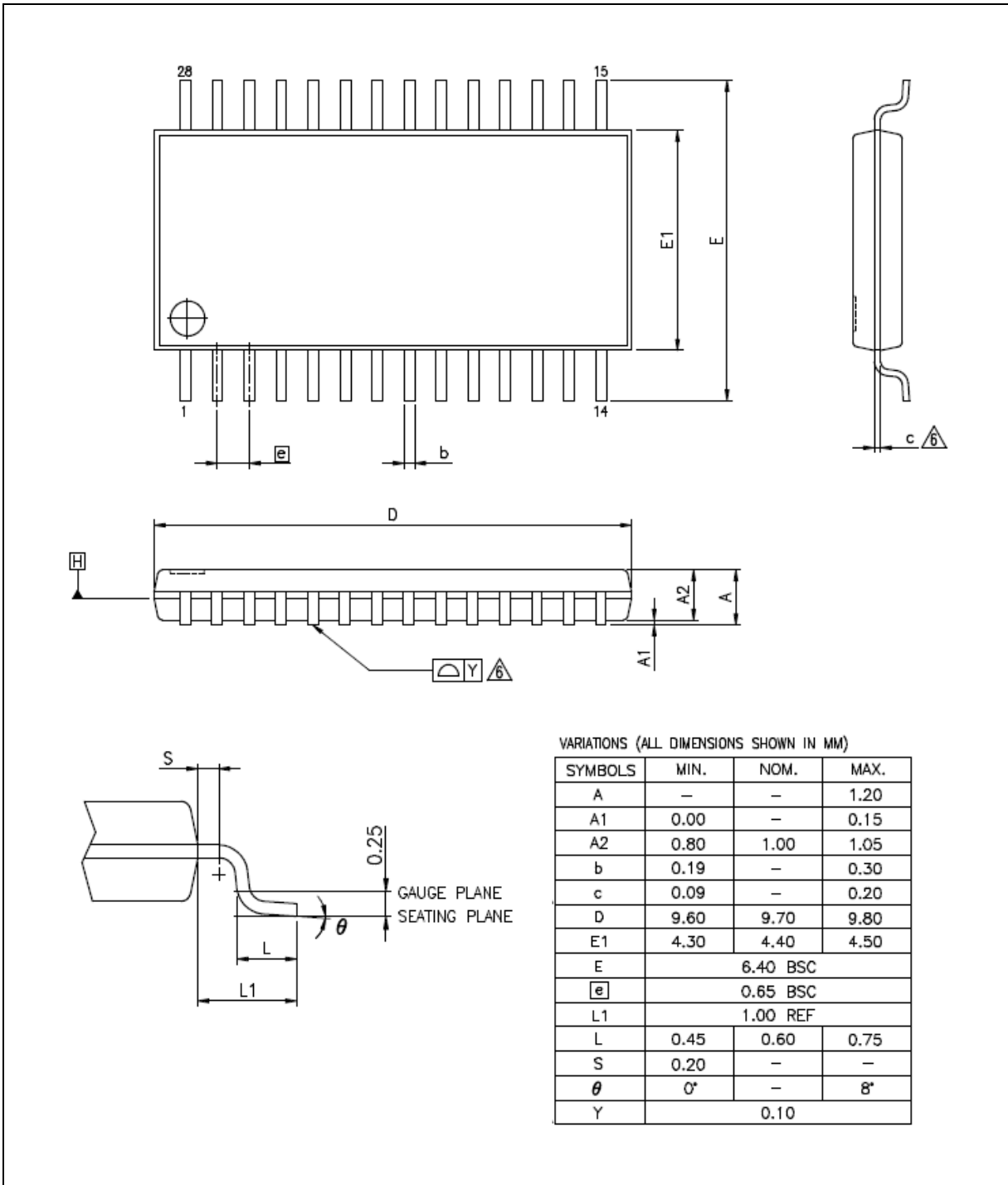



		SYMBOL	MIN	NOM	MAX
TOTAL THICKNESS		A	0.7	0.75	0.8
STAND OFF		A1	0	0.035	0.05
MOLD THICKNESS		A2	---	0.55	0.57
L/F THICKNESS		A3	0.203 REF		
LEAD WIDTH		b	0.2	0.25	0.3
BODY SIZE	X	D	5 BSC		
	Y	E	5 BSC		
LEAD PITCH		e	0.5 BSC		
EP SIZE	X	J	3.4	3.5	3.6
	Y	K	3.4	3.5	3.6
LEAD LENGTH		L	0.35	0.4	0.45
PACKAGE EDGE TOLERANCE		aaa	0.1		
MOLD FLATNESS		bbb	0.1		
COPLANARITY		ccc	0.08		
LEAD OFFSET		ddd	0.1		
EXPOSED PAD OFFSET		eee	0.1		

9.4 LQFP 48L (7x7x1.4 mm<sup>3</sup> Footprint 2.0 mm)

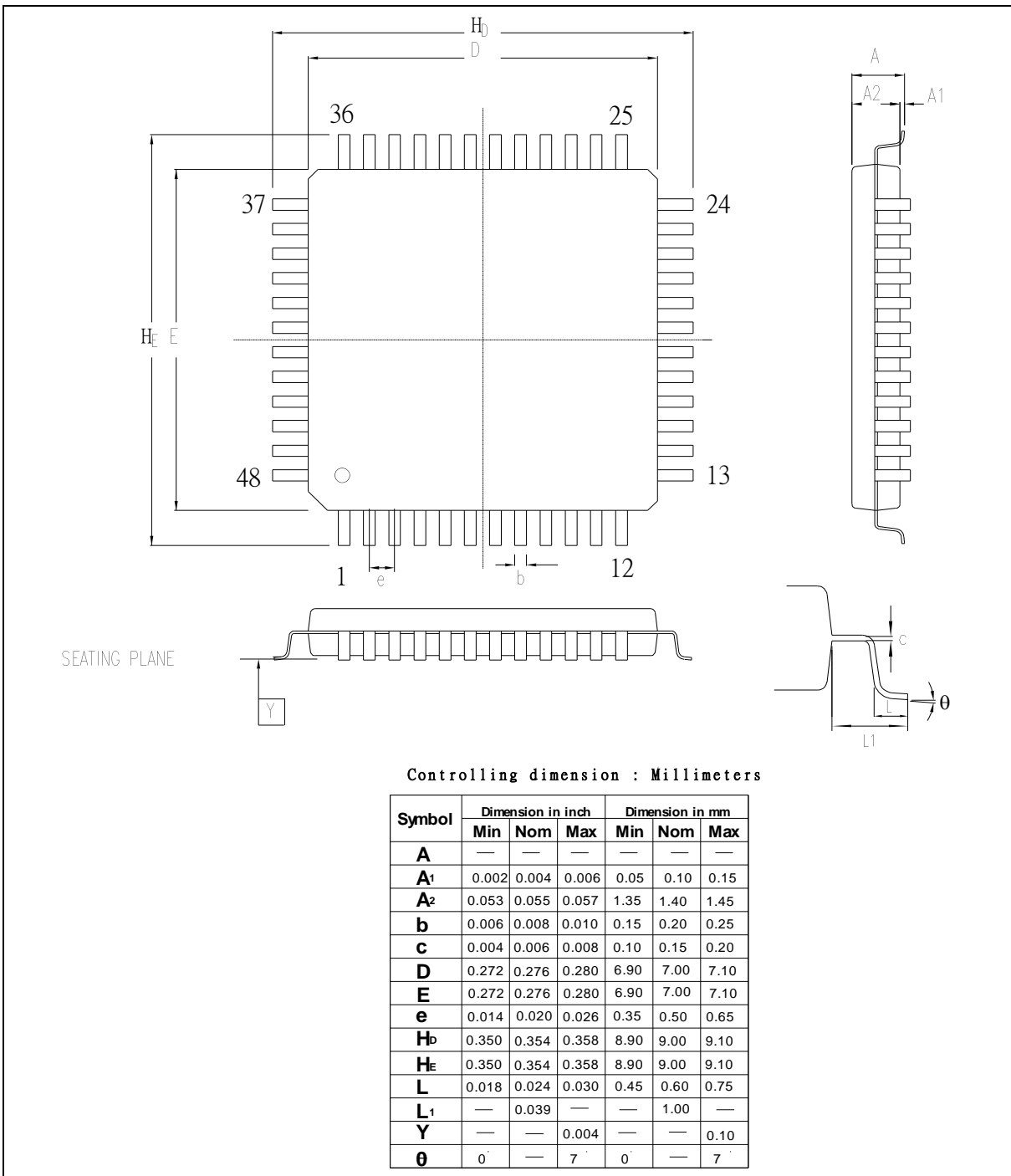

9.5 LQFP 64L (7x7x1.4 mm<sup>3</sup> Footprint 2.0 mm)

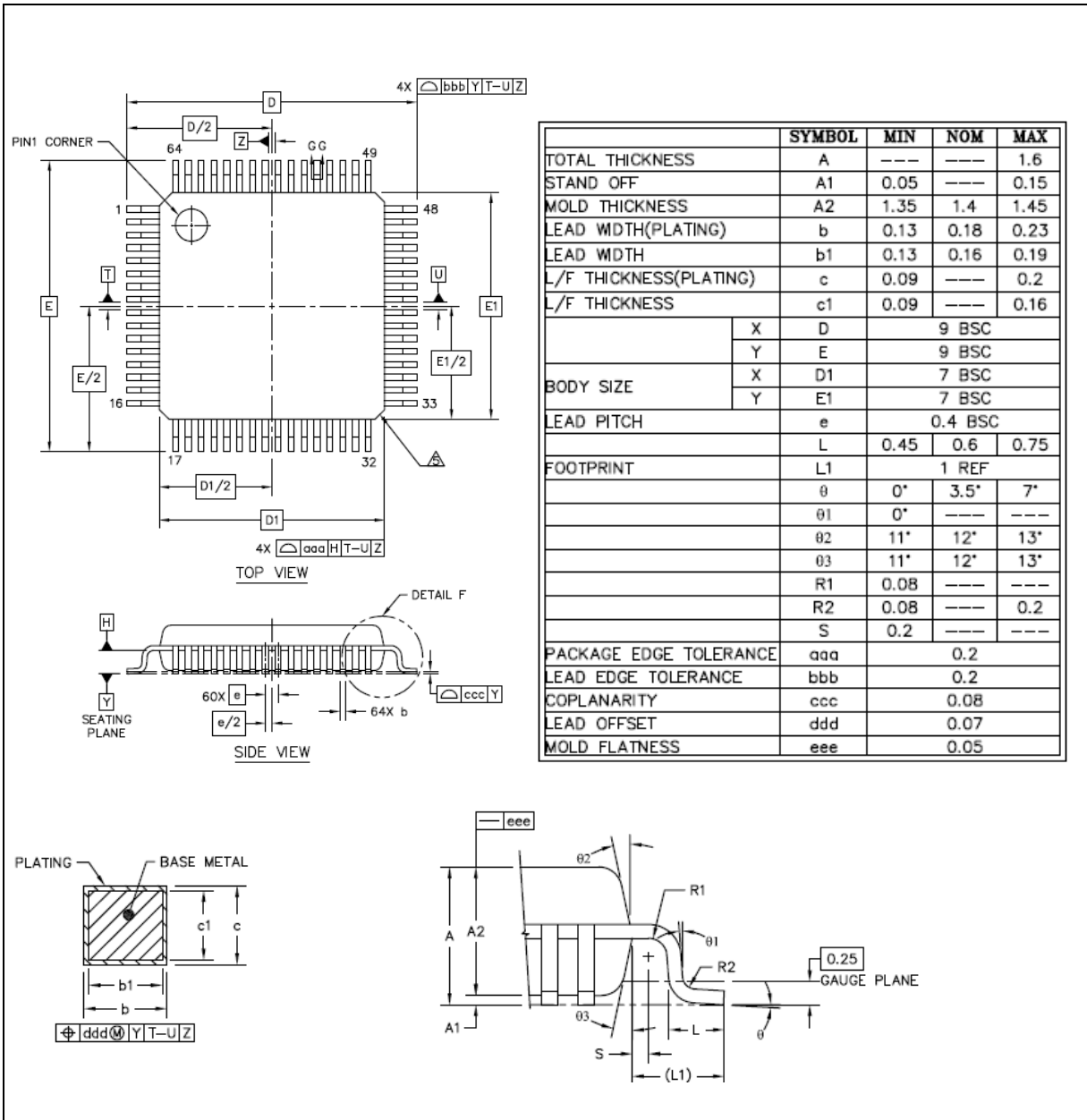

9.6 LQFP 128L (14x14x1.4 mm<sup>3</sup> Footprint 2.0 mm)

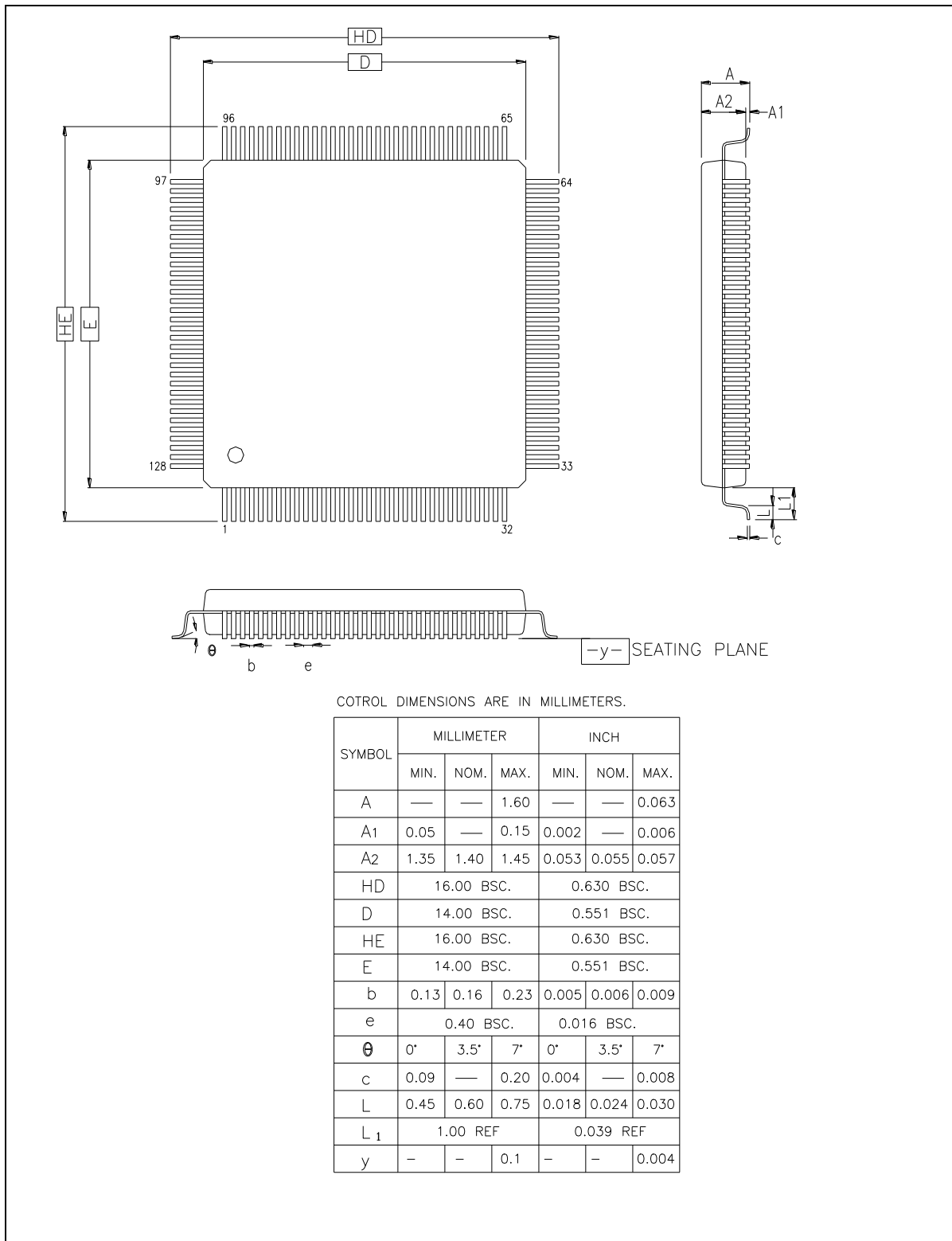

## 10 ABBREVIATIONS

### 10.1 Abbreviations

Acronym	Description
ACMP	Analog Comparator Controller
ADC	Analog-to-Digital Converter
AES	Advanced Encryption Standard
APB	Advanced Peripheral Bus
AHB	Advanced High-Performance Bus
BOD	Brown-out Detection
CAN	Controller Area Network
DAP	Debug Access Port
DES	Data Encryption Standard
EADC	Enhanced Analog-to-Digital Converter
EBI	External Bus Interface
EMAC	Ethernet MAC Controller
EPWM	Enhanced Pulse Width Modulation
FIFO	First In, First Out
FMC	Flash Memory Controller
FPU	Floating-point Unit
GPIO	General-Purpose Input/Output
HCLK	The Clock of Advanced High-Performance Bus
HIRC	12 MHz Internal High Speed RC Oscillator
HXT	4~24 MHz External High Speed Crystal Oscillator
IAP	In Application Programming
ICP	In Circuit Programming
ISP	In System Programming
LDO	Low Dropout Regulator
LIN	Local Interconnect Network
LIRC	10 kHz internal low speed RC oscillator (LIRC)
MPU	Memory Protection Unit
NVIC	Nested Vectored Interrupt Controller
PCLK	The Clock of Advanced Peripheral Bus
PDMA	Peripheral Direct Memory Access
PLL	Phase-Locked Loop
PWM	Pulse Width Modulation

QEI	Quadrature Encoder Interface
SD	Secure Digital
SPI	Serial Peripheral Interface
SPS	Samples per Second
TDES	Triple Data Encryption Standard
TK	Touch Key
TMR	Timer Controller
UART	Universal Asynchronous Receiver/Transmitter
UCID	Unique Customer ID
USB	Universal Serial Bus
WDT	Watchdog Timer
WWDT	Window Watchdog Timer

Table 10.1-1 List of Abbreviations

11 REVISION HISTORY

Date	Revision	Description
2020.04.10	1.00	<ul style="list-style-type: none"> <li>Initial version.</li> </ul>
2020.07.02	1.01	<ul style="list-style-type: none"> <li>Revised stable time test condition of internal reference voltage in section 8.5.7.</li> <li>Revised R<sub>ADD</sub> connection that is closed to XT1_OUT pin in Table 8.4-5.</li> <li>Revised t<sub>WU_DPD</sub> value in Table 8.3-8.</li> <li>Revised application circuit in Chapter 7.</li> <li>Revised I<sub>DD_FWPD</sub> value in Table 8.3-3.</li> <li>Added a 10Ω series resistor on USB_Vbus in section 7.2.</li> <li>Updated OPA characteristics in section 8.5.6.</li> <li>Updated supply current characteristics for M251xE/M251xG/M252xE/M252xG in section 8.3.2.</li> </ul>
2021.07.30	1.02	<ul style="list-style-type: none"> <li>Revised the ADC conversion rate from 880 kSPS to 730 kSPS for continuous mode.</li> <li>Removed the ferrite bead between V<sub>DD</sub> and V<sub>BAT</sub> in section 7.1.</li> <li>Added latch-up class level in Table 8.1-4 and Table 8.1-5.</li> <li>Updated TBD items of deep power-down current in Table 8.3-6.</li> <li>Revised I/O sink current and source current in Table 8.3-11.</li> <li>Revised t<sub>FR</sub> characteristics in Table 8.3-12.</li> <li>Revised f<sub>HRC</sub> characteristics in Table 8.4-1.</li> <li>Revised the max. operation current of LIRC from 1.0 to 1.3 μA in Table 8.4-3.</li> <li>Removed L0 ~ L2 gain level of LXT in Table 8.4-9.</li> <li>Added the BOD test condition in Table 8.5-1.</li> <li>Revised ADC characteristics in Table 8.5-2.</li> <li>Revised Flash characteristics in Table 8.7-1.</li> </ul>
2023.02.08	1.03	<ul style="list-style-type: none"> <li>Added “Package is Halogen-free, RoHS-compliant and TSCA-compliant.” in Chapter 3 and 9.</li> <li>Revised ESD HBM spec to show final test result for M251xE and M252xE in Table 8.1-5</li> </ul>

### Important Notice

Nuvoton Products are neither intended nor warranted for usage in systems or equipment, any malfunction or failure of which may cause loss of human life, bodily injury or severe property damage. Such applications are deemed, "Insecure Usage".

Insecure usage includes, but is not limited to: equipment for surgical implementation, atomic energy control instruments, airplane or spaceship instruments, the control or operation of dynamic, brake or safety systems designed for vehicular use, traffic signal instruments, all types of safety devices, and other applications intended to support or sustain life.

All Insecure Usage shall be made at customer's risk, and in the event that third parties lay claims to Nuvoton as a result of customer's Insecure Usage, customer shall indemnify the damages and liabilities thus incurred by Nuvoton.

---

*Please note that all data and specifications are subject to change without notice.  
All the trademarks of products and companies mentioned in this datasheet belong to their respective owners.*

## Looking for pricing, stock, or lifecycle information?

Click below to explore more details on WIN SOURCE:

- ⊖ [View M251LD2AE on WIN SOURCE](#)
- ⊖ [Nuvoton Technology Corporation of America Information](#)

## Optimize Your Supply Chain with WIN SOURCE Solutions

- ✓ Global Sourcing Solution
- ✓ Obsolete Management
- ✓ Cost Control Management
- ✓ Shortage Management
- ✓ Alternative Solution
- ✓ Excess Inventory Management