



**THE DATASHEET OF  
DLP670SFYR**



## DLP670S 0.67 2716 × 1600 DMD

### 1 Features

- High resolution 2716 × 1600 array
  - >4.3 million micromirrors
  - 0.67-inch micromirror array diagonal
  - 5.4-micron micromirror pitch
  - ±17.5° micromirror tilt angle (relative to flat surface)
  - Designed for bottom illumination
  - Integrated micromirror driver circuitry
- Designed for use with broadband visible light (420 nm–700 nm)
  - Window transmission 97% (single pass, through two window surfaces)
  - Micromirror reflectivity 88%
  - Array diffraction efficiency 84% (@f/2.4)
  - Array fill factor 93%
- Four 16-bit, low voltage differential signaling (LVDS), double data rate (DDR) input-data buses
- Driven by dual DLPC900 digital controllers
  - Up to 9523-Hz 1-bit patterns/second
  - Equivalent to 41.3 gigabits/second pixel data rate in a prestored pattern mode
  - Up to 1190-Hz, 8-bit gray pattern rate (prestored patterns with illumination modulation)
  - Up to 247-Hz, 8-bit pattern rate (external video pattern input)

### 2 Applications

- Industrial**
  - 3D scanners for machine vision
  - 3D touchless metrology and quality control
  - 3D printing
- Medical**
  - Ophthalmology
  - 3D scanners for limb and skin measurement
  - Hyperspectral scanning and imaging
- Displays**
  - 3D imaging microscopes
  - Intelligent and adaptive lighting

### 3 Description

Featuring over 4.3 million micromirrors, the DLP670S digital micromirror device (DMD) is a spatial light modulator (SLM) that modulates the amplitude, direction, and phase of incoming light. This DMD coupled with its four 2xLVDS input data buses enables the display of high-resolution patterns at very fast pattern rates. The high resolution and fast pattern rates offered by the DLP670S make it well-suited to support a wide variety of industrial, medical, and advanced imaging applications. Reliable function and operation of the DLP670S is enabled in conjunction with dual DLPC900 digital controllers. This dedicated chipset provides flexible and easy-to-program patterns at the high pattern rates necessary to meet the requirements of a variety of end-equipment solutions.

The high resolution provides a direct benefit to the scanning of larger objects in 3D machine vision applications.

Get started with [TI DLP® advanced light-control technology page](#) to learn how to get started with the [DLP670S](#). The DLP advanced light control resources on [TI.com](#) accelerate time to market, which include [evaluation modules](#), [reference designs](#), [optical modules manufacturers](#), and [DLP design network partners](#).

**Table 3-1. Device Information**

PART NUMBER	PACKAGE	BODY SIZE (NOM)
DLP670S <sup>(1)</sup>	FYR (350)	35 mm × 32 mm

(1) For all available packages, see the orderable addendum at the end of the data sheet.

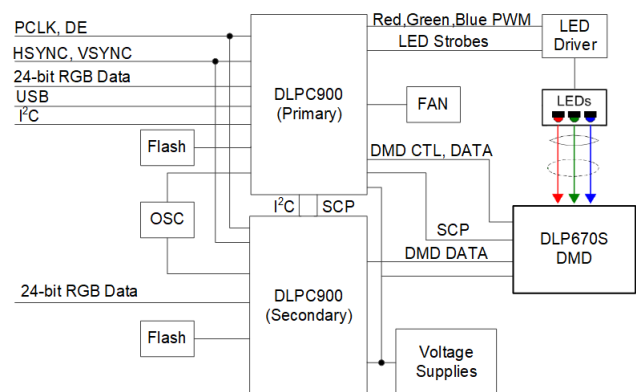

**DLP670S Simplified Schematic**



## Table of Contents

<b>1 Features</b> .....	1	7.5 Optical Interface and System Image Quality.....	27
<b>2 Applications</b> .....	1	7.6 Micromirror Array Temperature Calculation.....	28
<b>3 Description</b> .....	1	7.7 Micromirror Landed-On/Landed-Off Duty Cycle.....	30
<b>4 Revision History</b> .....	2	<b>8 Application and Implementation</b> .....	33
<b>5 Pin Configuration and Functions</b> .....	3	8.1 Application Information.....	33
<b>6 Specifications</b> .....	12	8.2 Typical Application.....	33
6.1 Absolute Maximum Ratings.....	12	8.3 DMD Die Temperature Sensing.....	35
6.2 Storage Conditions.....	13	<b>9 Power Supply Recommendations</b> .....	36
6.3 ESD Ratings.....	13	9.1 DMD Power Supply Power-Up Procedure.....	36
6.4 Recommended Operating Conditions.....	13	9.2 DMD Power Supply Power-Down Procedure.....	36
6.5 Thermal Information.....	16	9.3 Restrictions on Hot Plugging and Hot Swapping.....	38
6.6 Electrical Characteristics.....	16	<b>10 Layout</b> .....	38
6.7 Capacitance at Recommended Operating Conditions.....	16	10.1 Layout Guidelines.....	38
6.8 Timing Requirements.....	17	10.2 Layout Example.....	41
6.9 Typical Characteristics.....	20	<b>11 Device and Documentation Support</b> .....	43
6.10 System Mounting Interface Loads.....	20	11.1 Third-Party Products Disclaimer.....	43
6.11 Micromirror Array Physical Characteristics.....	21	11.2 Device Support.....	43
6.12 Micromirror Array Optical Characteristics.....	23	11.3 Documentation Support.....	44
6.13 Window Characteristics.....	25	11.4 Receiving Notification of Documentation Updates..	44
6.14 Chipset Component Usage Specification.....	25	11.5 Support Resources.....	44
<b>7 Detailed Description</b> .....	26	11.6 Trademarks.....	44
7.1 Overview.....	26	11.7 Electrostatic Discharge Caution.....	44
7.2 Functional Block Diagram.....	26	11.8 Glossary.....	44
7.3 Feature Description.....	27	<b>12 Mechanical, Packaging, and Orderable Information</b> .....	45
7.4 Device Functional Modes.....	27		

## 4 Revision History

Changes from Revision * (November 2020) to Revision A (June 2022)	Page
• This document is updated to the latest Texas Instruments and industry data sheet standards.....	1
• Updated the ESD ratings per the latest standards.....	13
• Corrected Note <sup>(6)</sup> LVCMOS Interface.....	13
• Changed SCP specifications to reflect 'Rise/Fall Time'.....	17
• Corrected figure <a href="#">Figure 6-3</a> .....	17

## 5 Pin Configuration and Functions

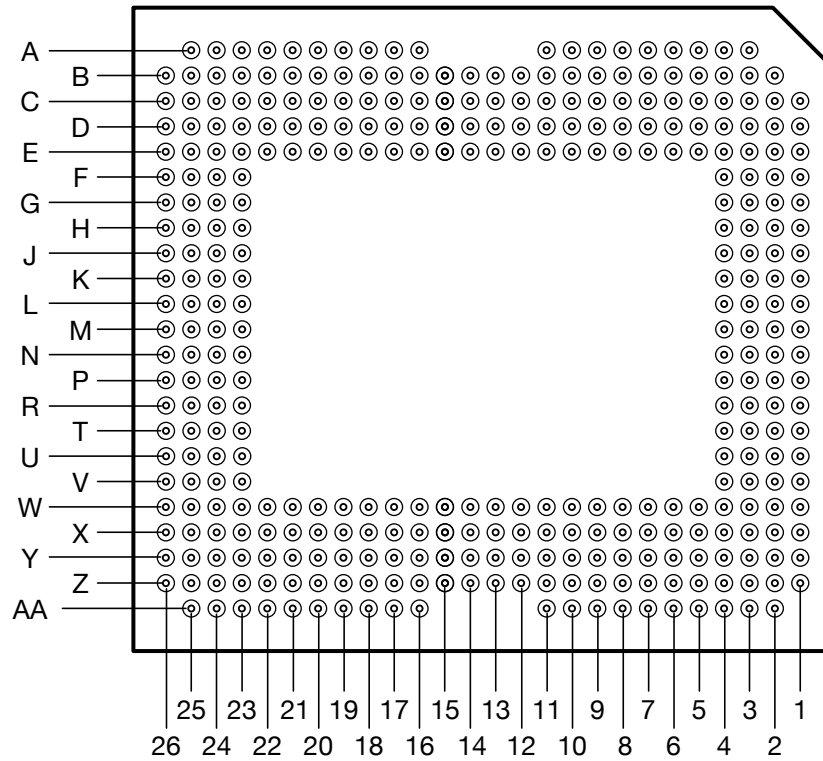

**Figure 5-1. FYR Package 350-Pin CPGA Bottom View**

**CAUTION**

To ensure reliable, long-term operation of the DLP670S DMD, it is critical to properly manage the layout and operation of the signals identified in the table below. For specific details and guidelines, refer to [Section 10.1](#) before designing the board.

Table 5-1. Pin Functions<sup>(1)</sup>

PIN <sup>(2)</sup>		TYPE (I/O/P)	SIGNAL	DATA RATE <sup>(4)</sup>	INTERNAL TERM <sup>(5)</sup>	DESCRIPTION	TRACE (mils) <sup>(6)</sup>
NAME	NO.						
<b>DATA INPUTS</b>							
D_AN(0)	C7	Input	2xLVDS	DDR	Differential	LVDS pair for Data Bus A (15:0)	563
D_AP(0)	C8						
D_AN(1)	D4						
D_AP(1)	E4						
D_AN(2)	C5						
D_AP(2)	C4						
D_AN(3)	D6						
D_AP(3)	C6						
D_AN(4)	D8						
D_AP(4)	D7						
D_AN(5)	D3						
D_AP(5)	E3						
D_AN(6)	B3						
D_AP(6)	C3						
D_AN(7)	E11						
D_AP(7)	E10						
D_AN(8)	E6						
D_AP(8)	E5						
D_AN(9)	B10						
D_AP(9)	C10						
D_AN(10)	B8						
D_AP(10)	B9						
D_AN(11)	C13						
D_AP(11)	C14						
D_AN(12)	D15						
D_AP(12)	E15						
D_AN(13)	B12						
D_AP(13)	B13						
D_AN(14)	B15						
D_AP(14)	B16						
D_AN(15)	C16						
D_AP(15)	C17						

**Table 5-1. Pin Functions<sup>(1)</sup> (continued)**

PIN <sup>(2)</sup>		TYPE (I/O/P)	SIGNAL	DATA RATE <sup>(4)</sup>	INTERNAL TERM <sup>(5)</sup>	DESCRIPTION	TRACE (mils) <sup>(6)</sup>
NAME	NO.						
D_BN(0)	Y8	Input	2xLVDS	DDR	Differential	LVDS pair for Data Bus B (15:0)	563
D_BP(0)	Y7						
D_BN(1)	X4						
D_BP(1)	W4						
D_BN(2)	Z3						
D_BP(2)	Y3						
D_BN(3)	X6						
D_BP(3)	Y6						
D_BN(4)	X8						
D_BP(4)	X7						
D_BN(5)	X3						
D_BP(5)	W3						
D_BN(6)	W15						
D_BP(6)	X15						
D_BN(7)	W11						
D_BP(7)	W10						
D_BN(8)	W6						
D_BP(8)	W5						
D_BN(9)	AA9						
D_BP(9)	AA10						
D_BN(10)	Z8						
D_BP(10)	Z9						
D_BN(11)	Y13						
D_BP(11)	Y14						
D_BN(12)	Z10						
D_BP(12)	Y10						
D_BN(13)	Z12						
D_BP(13)	Z13						
D_BN(14)	Z15						
D_BP(14)	Z16						
D_BN(15)	Y16						
D_BP(15)	Y17						

Table 5-1. Pin Functions<sup>(1)</sup> (continued)

PIN <sup>(2)</sup>		TYPE (I/O/P)	SIGNAL	DATA RATE <sup>(4)</sup>	INTERNAL TERM <sup>(5)</sup>	DESCRIPTION	TRACE (mils) <sup>(6)</sup>
NAME	NO.						
D_CN(0)	C18	Input	2xLVDS	DDR	Differential	LVDS pair for Data Bus C (15:0)	563
D_CP(0)	C19						
D_CN(1)	A20						
D_CP(1)	A19						
D_CN(2)	L23						
D_CP(2)	K23						
D_CN(3)	C23						
D_CP(3)	B23						
D_CN(4)	G23						
D_CP(4)	H23						
D_CN(5)	H24						
D_CP(5)	G24						
D_CN(6)	B18						
D_CP(6)	B19						
D_CN(7)	C21						
D_CP(7)	B21						
D_CN(8)	D23						
D_CP(8)	E23						
D_CN(9)	D25						
D_CP(9)	C25						
D_CN(10)	L24						
D_CP(10)	K24						
D_CN(11)	K25						
D_CP(11)	J25						
D_CN(12)	B24						
D_CP(12)	A24						
D_CN(13)	D26						
D_CP(13)	C26						
D_CN(14)	G25						
D_CP(14)	F25						
D_CN(15)	K26						
D_CP(15)	J26						

**Table 5-1. Pin Functions<sup>(1)</sup> (continued)**

PIN <sup>(2)</sup>		TYPE (I/O/P)	SIGNAL	DATA RATE <sup>(4)</sup>	INTERNAL TERM <sup>(5)</sup>	DESCRIPTION	TRACE (mils) <sup>(6)</sup>
NAME	NO.						
D_DN(0)	Y18	Input	2xLVDS	DDR	Differential	LVDS pair for Data Bus D (15:0)	563
D_DP(0)	Y19						
D_DN(1)	AA20						
D_DP(1)	AA19						
D_DN(2)	N23						
D_DP(2)	P23						
D_DN(3)	Y23						
D_DP(3)	Z23						
D_DN(4)	U23						
D_DP(4)	T23						
D_DN(5)	T24						
D_DP(5)	U24						
D_DN(6)	Z18						
D_DP(6)	Z19						
D_DN(7)	Y21						
D_DP(7)	Z21						
D_DN(8)	X23						
D_DP(8)	W23						
D_DN(9)	X25						
D_DP(9)	Y25						
D_DN(10)	N24						
D_DP(10)	P24						
D_DN(11)	P25						
D_DP(11)	R25						
D_DN(12)	Z24						
D_DP(12)	AA24						
D_DN(13)	X26						
D_DP(13)	Y26						
D_DN(14)	U25						
D_DP(14)	V25						
D_DN(15)	P26						
D_DP(15)	R26						
DCLK_AN	B6	Input	LVDS		Differential	LVDS pair for Data Clock A <sup>(7)</sup>	563
DCLK_AP	B5	Input	LVDS		Differential	LVDS pair for Data Clock B <sup>(7)</sup>	563
DCLK_BN	Z6						
DCLK_BP	Z5	Input	LVDS		Differential	LVDS pair for Data Clock C <sup>(7)</sup>	563
DCLK_CN	G26						
DCLK_CP	F26	Input	LVDS		Differential	LVDS pair for Data Clock D <sup>(7)</sup>	563
DCLK_DN	U26						
DCLK_DP	V26						
<b>DATA CONTROL INPUTS</b>							
SCTRL_AN	A10	Input	LVDS	DDR	Differential	LVDS pair for Serial Control (Sync) A <sup>(7)</sup>	563
SCTRL_AP	A9						

Table 5-1. Pin Functions<sup>(1)</sup> (continued)

PIN <sup>(2)</sup>		TYPE (I/O/P)	SIGNAL	DATA RATE <sup>(4)</sup>	INTERNAL TERM <sup>(5)</sup>	DESCRIPTION	TRACE (mils) <sup>(6)</sup>
NAME	NO.						
SCTRL_BN	Y4	Input	LVDS	DDR	Differential	LVDS pair for Serial Control (Sync) B <sup>(7)</sup>	563
SCTRL_BP	Y5						
SCTRL_CN	E24	Input	LVDS	DDR	Differential	LVDS pair for Serial Control (Sync) C <sup>(7)</sup>	563
SCTRL_CP	D24						
SCTRL_DN	W24	Input	LVDS	DDR	Differential	LVDS pair for Serial Control (Sync) D <sup>(7)</sup>	563
SCTRL_DP	X24						
<b>DAD CONTROL INPUTS</b>							
RESET_ADDR(0)	R3	Input	LVCMOS		Pull-down	Reset Driver Address Select. Bond pad connects to an internal pull-down circuit. <sup>(7)</sup>	
RESET_ADDR(1)	R4						
RESET_ADDR(2)	T3						
RESET_ADDR(3)	U2						
RESET_MODE(0)	P4	Input	LVCMOS		Pull-down	Reset Driver Mode Select. Bond pad connects to an internal pull-down circuit. <sup>(7)</sup>	
RESET_MODE(1)	V3						
RESET_OEZ	R2	Input	LVCMOS		Pull-up	Active Low. Output Enable signal for internal Reset Driver circuitry. Bond Pad connects to an internal pull-up circuit. <sup>(7)</sup>	
RESET_SEL(0)	P3	Input	LVCMOS		Pull-down	Reset Driver Level Select. Bond pad connects to an internal pull-down circuit. <sup>(7)</sup>	
RESET_SEL(1)	V2						
RESET_STROBE	W8	Input	LVCMOS		Pull-down	Rising edge on RESET_STROBE latches in the control signals. Bond pad connects to an internal pull-down circuit. <sup>(7)</sup>	
RESETZ	U4	Input	LVCMOS		Pull-up	Active Low. Places reset circuitry in known VOFFSET state. Bond pad connects to an internal pull-down circuit. <sup>(7)</sup>	
<b>SCP CONTROL</b>							
SCPCLK	W17	Input	LVCMOS		Pull-down	Serial Communications Port Clock. SCPCLK is only active when SCPENZ goes low. Bond pad connects to an internal pull-down circuit. <sup>(7)</sup>	
SCPDI	W18	Input	LVCMOS	SDR	Pull-down	Serial Communications Port Data. Synchronous to the Rising Edge of SCPCLK. Bond pad connects to an internal pull-down circuit. <sup>(7)</sup>	
SCPENZ	X18	Input	LVCMOS		Pull-down	Active Low Serial Communications Port Enable. Bond pad connects to an internal pull-down circuit. <sup>(7)</sup>	
SCPDO	W16	Output	LVCMOS	SDR		Serial Communications Port output	
<b>EXTERNAL REGULATOR SIGNALS</b>							
EN_BIAS	J4	Output	LVCMOS			Active High. Enable signal for external VBIAS regulator	
EN_OFFSET	H3	Output	LVCMOS			Active High. Enable signal for external VOFFSET regulator	

**Table 5-1. Pin Functions<sup>(1)</sup> (continued)**

PIN <sup>(2)</sup>		TYPE (I/O/P)	SIGNAL	DATA RATE <sup>(4)</sup>	INTERNAL TERM <sup>(5)</sup>	DESCRIPTION	TRACE (mils) <sup>(6)</sup>
NAME	NO.						
EN_RESET	J3	Output	LVC MOS			Active High. Enable signal for external VRESET regulator	
PG_BIAS	K3	Input	LVC MOS			Active low fault from external VBIAS regulator <sup>(7)</sup>	
PG_OFFSET	F2	Input	LVC MOS			Active low fault from external VOFFSET regulator <sup>(7)</sup>	
PG_RESET	F3	Input	LVC MOS			Active low fault from external VRESET regulator <sup>(7)</sup>	
<b>OTHER SIGNALS</b>							
RESET_IRQZ	U3	Output	LVC MOS			Active Low. Output Interrupt to DLP controller (ASIC)	
TEMP_PLUS	E16	Input	Analog			Temperature Sensor Diode Anode <sup>(3)</sup>	
TEMP_MINUS	E17	Input	Analog			Temperature Sensor Diode Cathode <sup>(3)</sup>	
<b>POWER</b>							
VBIAS	A5, A6, A7, AA5, AA6, AA7	Power	Analog			Power supply for Positive Bias level of micromirror reset signal	
VCC	A8, B2, C1, D1, D10, D12, D19, E1, E19, E20, E21, F1, K1, L1, M1, N1, P1, V1, W1, W19, W20, W21, X1, X10, X12, X19, Y1, Z1, Z2, AA2, AA8,	Power	Analog			Power supply for low voltage CMOS logic. Power supply for normal high voltage at micromirror address electrodes. Power supply for Offset level during the power-down sequence	
VCCI	A11, A16, A17, A18, A21, A22, A23, AA11, AA16, AA17, AA18, AA21, AA22, AA23,	Power	Analog			Power supply for low voltage CMOS LVDS interface	
VOFFSET	A3, A4, A25, B26, L26, M26, N26, Z26, AA3, AA4, AA25	Power	Analog			Power supply for high voltage CMOS logic. Power supply for stepped high voltage at micromirror address electrodes. Power supply for Offset level of MBRST(15:0)	
VRESET	G1, H1, J1, R1, T1, U1	Power	Analog			Power supply for Negative Reset level of micromirror reset signal	

Table 5-1. Pin Functions<sup>(1)</sup> (continued)

PIN <sup>(2)</sup>		TYPE (I/O/P)	SIGNAL	DATA RATE <sup>(4)</sup>	INTERNAL TERM <sup>(5)</sup>	DESCRIPTION	TRACE (mils) <sup>(6)</sup>
NAME	NO.						
V <sub>SS</sub> (Ground)	B4, B7, B11, B14, B17, B20, B22, B25, C2, C9, C20, C22, C24, D2, D5, D9, D11, D14, D18, D20, D21, D22, E2, E7, E9, E22, E25, E26, F4, F23, F24, H2, H4, H25, H26, J23, J24, K2, L2, L3, L4, L25, M2, M3, M4, M23, M24, M25, N2, N3, N25, P2,R23, R24, T2, T4, T25, T26, V4, V23, V24, W2, W7, W9, W22, W25, W26, X2, X5, X9, X11, X14, X20, X21, X22, Y2, Y9, Y20, Y22, Y24, Z4, Z7, Z11, Z14, Z17, Z20, Z22, Z25	Ground				Common Return for all power	
<b>RESERVED SIGNALS</b>							
RESERVED_PFE	E18	Ground	LVC MOS			Do Not Connect on the printed circuit board (PCB)	
RESERVED_TM	G4	Ground	LVC MOS			Do Not Connect on the printed circuit board (PCB)	
RESERVED_TP0	E8	Input	Analog			Do Not Connect on the printed circuit board (PCB)	
RESERVED_TP1	J2	Input	Analog			Do Not Connect on the printed circuit board (PCB)	
RESERVED_TP2	G2	Input	Analog			Do Not Connect on the printed circuit board (PCB)	
RESERVED_BA	N4	Output	LVC MOS			Do Not Connect on the printed circuit board (PCB)	
RESERVED_BB	K4	Output	LVC MOS			Do Not Connect on the printed circuit board (PCB)	
RESERVED_BC	X17	Output	LVC MOS			Do Not Connect on the printed circuit board (PCB)	
RESERVED_BD	D17	Output	LVC MOS			Do Not Connect on the printed circuit board (PCB)	

**Table 5-1. Pin Functions<sup>(1)</sup> (continued)**

PIN <sup>(2)</sup>		TYPE (I/O/P)	SIGNAL	DATA RATE <sup>(4)</sup>	INTERNAL TERM <sup>(5)</sup>	DESCRIPTION	TRACE (mils) <sup>(6)</sup>
NAME	NO.						
NO CONNECT	C11, C12, C15, D13, D16, E12, E13, E14, W13, W12, W14, X13, X16, Y11, Y12, Y15,	NC				For TI Test Purposes only, Do Not Connect on the printed circuit board (PCB)	

- (1) The DLP670S DMD is a component of a DLP® chipset. Reliable function and operation of the DLP670S DMD requires that it be used in conjunction with the other components of the applicable DLP® chipset, including those components that contain or implement TI DMD control technology. TI DMD control technology is the TI technology and devices for operating or controlling a DLP® DMD.
- (2) The following power supplies are required for all DMD operating modes: VSS, VBIAS, VCC, VCCI, VOFFSET, and VRESET.
- (3) VSS must be connected for proper DMD operation.
- (4) DDR = Double Data Rate, SDR = Single Data Rate. Refer to the [Timing Requirements](#) for specifications and relationships.
- (5) Internal term = CMOS level internal termination. Refer to [Recommended Operating Conditions](#) for differential termination specification.
- (6) Dielectric Constant for the DMD FYR (S610) ceramic package is approximately 9.6. For the package trace lengths shown: Propagation Speed =  $11.8 / \sqrt{9.6} = 3.808$  in/ns. Propagation Delay =  $0.262$  ns/in =  $10.315$  ps/mm.
- (7) These signals are very sensitive to noise or intermittent power connections, which can cause irreversible DMD micromirror array damage or, to a lesser extent, image disruption. Consider this precaution during DMD board design and manufacturer handling of the DMD sub-assemblies.

## 6 Specifications

### 6.1 Absolute Maximum Ratings

over operating free-air temperature range (unless otherwise noted) <sup>(1)</sup>

		MIN	MAX	UNIT
<b>SUPPLY VOLTAGES</b>				
$V_{CC}$	Supply voltage for LVCMOS core logic <sup>(2)</sup>	-0.5	2.3	V
$V_{CCI}$	Supply voltage for LVDS receivers <sup>(2)</sup>	-0.5	2.3	V
$V_{OFFSET}$	Supply voltage for HVCMOS and micromirror electrode <sup>(2) (3)</sup>	-0.5	11	V
$V_{BIAS}$	Supply voltage for micromirror electrode <sup>(2)</sup>	-0.5	19	V
$V_{RESET}$	Supply voltage for micromirror electrode <sup>(2)</sup>	-15	-0.3	V
$ V_{CC} - V_{CCI} $	Supply voltage delta (absolute value) <sup>(4)</sup>		0.3	V
$ V_{BIAS} - V_{OFFSET} $	Supply voltage delta (absolute value) <sup>(5)</sup>		11	V
$ V_{BIAS} - V_{RESET} $	Supply voltage delta (absolute value) <sup>(6)</sup>		34	V
<b>INPUT VOLTAGES</b>				
	Input voltage for all other LVCMOS input pins <sup>(2)</sup>	-0.5	$V_{CC} + 0.5$	V
	Input voltage for all other LVDS input pins <sup>(2) (6)</sup>	-0.5	$V_{CCI} + 0.5$	V
$ V_{ID} $	Input differential voltage (absolute value) <sup>(6)</sup>		500	mV
$I_{ID}$	Input differential current <sup>(7)</sup>		6.25	mA
<b>CLOCKS</b>				
$f_{CLOCK}$	Clock frequency for LVDS interface: DCLK_A, DCLK_B, DCLK_C, DCLK_D		400	MHz
<b>ENVIRONMENTAL</b>				
$T_{ARRAY}$ and $T_{WINDOW}$	Array temperature: operational <sup>(8)</sup>	0	90	°C
	Array temperature: non-operational <sup>(8)</sup>	-40	90	°C
$ T_{DELTA} $	Absolute temperature delta between any point on the window edge and the ceramic test point TP1 <sup>(9)</sup>		30	°C
$T_{DP}$	Dew point temperature, operating and non-operating (noncondensing)		81	°C

- (1) Operation outside the Absolute Maximum Ratings may cause permanent device damage. Absolute Maximum Ratings do not imply functional operation of the device at these or any other conditions beyond those listed under Recommended Operating Conditions. If outside the Recommended Operating Conditions but within the Absolute Maximum Ratings, the device may not be fully functional, and this may affect device reliability, functionality, performance, and shorten the device lifetime.
- (2) All voltages are referenced to common ground  $V_{SS}$ .  $V_{BIAS}$ ,  $V_{CC}$ ,  $V_{CCI}$ ,  $V_{OFFSET}$ , and  $V_{RESET}$  power supplies are all required for proper DMD operation.  $V_{SS}$  must also be connected.
- (3)  $V_{OFFSET}$  supply transients must fall within specified voltages.
- (4) Exceeding the recommended allowable voltage difference between  $V_{CC}$  and  $V_{CCI}$  may result in excessive current draw.
- (5) Exceeding the recommended allowable voltage difference between  $V_{BIAS}$  and  $V_{OFFSET}$  may result in excessive current draw.
- (6) Exceeding the recommended allowable voltage difference between  $V_{BIAS}$  and  $V_{RESET}$  may result in excessive current draw.
- (7) LVDS differential inputs must not exceed the specified limit or damage may result to the internal termination resistors.
- (8) The highest temperature of the active array (as calculated in [Section 7.6](#)) or of any location along the window edge as defined in [Figure 7-1](#). The locations of thermal test points TP2, TP3, TP4, and TP5 in [Figure 7-1](#) are intended to measure the highest window edge temperature. If a particular application causes another location on the window edge to be at a higher temperature, use that location.
- (9) Temperature delta is the highest difference between the ceramic test point 1 (TP1) and anywhere on the window edge as shown in [Figure 7-1](#). The window test points TP2, TP3, TP4, and TP5 shown in [Figure 7-1](#) are intended to result in the worst case delta. If a particular application causes another location on the window edge to result in a larger delta temperature, use that location.

## 6.2 Storage Conditions

Applicable for the DMD as a component or non-operating in a system

		MIN	MAX	UNIT
$T_{DMD}$	DMD storage temperature	-40	80	°C
$T_{DP-AVG}$	Average dew point temperature, (non-condensing) <sup>(1)</sup>		28	°C
$T_{DP-ELR}$	Elevated dew point temperature range, (non-condensing) <sup>(2)</sup>	28	36	°C
$CT_{ELR}$	Cumulative time in elevated dew point temperature range		24	Months

- (1) The average over time (including storage and operating) that the device is not in the elevated dew point temperature range.  
(2) Limit the Exposure to dew point temperatures in the elevated range during storage and operation to less than a total cumulative time of  $CT_{ELR}$ .

## 6.3 ESD Ratings

		VALUE	UNIT
$V_{(ESD)}$	Electrostatic discharge		
	Human-body model (HBM), per ANSI/ESDA/JEDEC JS-001 <sup>(1)</sup>	±2000	V
Charged device model (CDM), per ANSI/ESDA/JEDEC JS-002 <sup>(2)</sup>	±500		

- (1) JEDEC document JEP155 states that 500-V HBM allows safe manufacturing with a standard ESD control process.  
(2) JEDEC document JEP157 states that 250-V CDM allows safe manufacturing with a standard ESD control process.

## 6.4 Recommended Operating Conditions

Over operating free-air temperature range (unless otherwise noted). The functional performance of the device specified in this data sheet is achieved when operating the device within the limits defined by Section 6.4. No level of performance is implied when operating the device above or below Section 6.4 limits.

		MIN	NOM	MAX	UNIT
<b>VOLTAGE SUPPLY</b>					
$V_{CC}$	LVC MOS logic supply voltage <sup>(1)</sup>	1.65	1.8	1.95	V
$V_{CCI}$	LVC MOS LVDS Interface supply voltage <sup>(1)</sup>	1.65	1.8	1.95	V
$V_{OFFSET}$	Mirror electrode and HVCMOS voltage <sup>(1) (2)</sup>	9.5	10	10.5	V
$V_{BIAS}$	Mirror electrode voltage <sup>(1)</sup>	17.5	18	18.5	V
$V_{RESET}$	Mirror electrode voltage <sup>(1)</sup>	-14.5	-14	-13.5	V
$ V_{CC} - V_{CCI} $	Supply voltage delta (absolute value) <sup>(3)</sup>		0	0.3	V
$ V_{BIAS} - V_{OFFSET} $	Supply voltage delta (absolute value) <sup>(4)</sup>			10.5	V
$ V_{BIAS} - V_{RESET} $	Supply voltage delta (absolute value) <sup>(5)</sup>			33	V
<b>LVC MOS INTERFACE</b>					
$V_{IH(DC)}$	DC input high voltage <sup>(6)</sup>	$0.7 \times V_{CC}$		$V_{CC} + 0.3$	V
$V_{IL(DC)}$	DC input low voltage <sup>(6)</sup>	-0.3		$0.3 \times V_{CC}$	V
$V_{IH(AC)}$	AC input high voltage <sup>(6)</sup>	$0.8 \times V_{CC}$		$V_{CC} + 0.3$	V
$V_{IL(AC)}$	AC input low voltage <sup>(6)</sup>	-0.3		$0.2 \times V_{CC}$	V
$t_{PWRDZ}$	PWRDZ pulse width <sup>(7)</sup>	10			ns
<b>SCP INTERFACE</b>					
$f_{SCPCLK}$	SCP clock frequency <sup>(8)</sup>			500	kHz
$t_{SCP\_PD}$	Propagation delay, Clock to Q, from rising-edge of SCPCLK to valid SCPDO <sup>(9)</sup>	0		900	ns
$t_{SCP\_NEG\_ENZ}$	Time between falling-edge of SCPENZ and the first rising edge of SCPCLK	2			µs
$t_{SCP\_POS\_ENZ}$	Time between falling-edge of SCPCLK and the rising edge of SCPENZ	2			µs
$t_{SCP\_DS}$	SCPDI Clock Setup time (before SCPCLK falling edge) <sup>(9)</sup>	800			ns
$t_{SCP\_DH}$	SCPDI Hold time (after SCPCLK falling edge) <sup>(9)</sup>	900			ns
$t_{SCP\_PW\_ENZ}$	SCPENZ inactive pulse width (high level)	2			µs

## 6.4 Recommended Operating Conditions (continued)

Over operating free-air temperature range (unless otherwise noted). The functional performance of the device specified in this data sheet is achieved when operating the device within the limits defined by [Section 6.4](#). No level of performance is implied when operating the device above or below [Section 6.4](#) limits.

		MIN	NOM	MAX	UNIT
<b>LVDS INTERFACE</b>					
$f_{\text{CLOCK}}$	Clock frequency for LVDS interface (all channels), DCLK <sup>(10)</sup>			400	MHz
$ V_{\text{ID}} $	Input differential voltage (absolute value) <sup>(11)</sup>	150	300	440	mV
$V_{\text{CM}}$	Common mode voltage <sup>(11)</sup>	1100	1200	1300	mV
$V_{\text{LVDS}}$	LVDS voltage <sup>(11)</sup>	880		1520	mV
$t_{\text{LVDS\_RSTZ}}$	Time required for LVDS receivers to recover from PWRDNZ			2000	ns
$Z_{\text{IN}}$	Internal differential termination resistance	80	100	120	$\Omega$
$Z_{\text{LINE}}$	Line differential impedance (PWB/trace)	90	100	110	$\Omega$
<b>ENVIRONMENTAL</b>					
$T_{\text{ARRAY}}$	Array temperature, long-term operational <sup>(12) (13) (14) (15)</sup>	10		40 to 70 <sup>(14)</sup>	$^{\circ}\text{C}$
	Array temperature, short-term operational <sup>(13) (16)</sup>	0		10	$^{\circ}\text{C}$
$T_{\text{WINDOW}}$	Window temperature — operational <sup>(17)</sup>			85	$^{\circ}\text{C}$
$ T_{\text{DELTA}} $	Absolute Temperature delta between any point on the window edge and the ceramic test point TP1 <sup>(17) (18)</sup>			14	$^{\circ}\text{C}$
$T_{\text{DP-AVG}}$	Average dew point temperature (non-condensing) <sup>(19)</sup>			28	$^{\circ}\text{C}$
$T_{\text{DP-ELR}}$	Elevated dew point temperature range (non-condensing) <sup>(20)</sup>	28		36	$^{\circ}\text{C}$
$CT_{\text{ELR}}$	Cumulative time in elevated dew point temperature range			24	Months
$ILL_{\theta}$	Illumination marginal ray angle <sup>(21)</sup>			55	deg
<b>For Illumination Source Between 420 nm and 700 nm</b>					
$ILL_{\text{VIS}}$	Illumination power density on array <sup>(22)</sup>			31	$\text{W}/\text{cm}^2$
$ILL_{\text{VISTP}}$	Illumination total power on array			39.3	W
<b>For Illumination Source &lt;420 nm and &gt;700 nm</b>					
$ILL_{\text{IR}}$	Illumination Wavelengths > 700 nm			10	$\text{mW}/\text{cm}^2$
$ILL_{\text{UV}}$	Illumination Wavelengths < 420 nm <sup>(12)</sup>			10	$\text{mW}/\text{cm}^2$

- (1) All voltages are referenced to common ground VSS. VBIAS, VCC, VCCI, VOFFSET, and VRESET power supplies are all required for proper DMD operation. VSS must also be connected.
- (2) VOFFSET supply transients must fall within specified max voltages.
- (3) To prevent excess current, the supply voltage delta  $|V_{\text{CCI}} - V_{\text{CC}}|$  must be less than specified limit. See [Section 9](#), [Figure 9-1](#), and [Table 9-1](#).
- (4) To prevent excess current, the supply voltage delta  $|V_{\text{BIAS}} - V_{\text{OFFSET}}|$  must be less than specified limit. See [Section 9](#), [Figure 9-1](#), and [Table 9-1](#).
- (5) To prevent excess current, the supply voltage delta  $|V_{\text{BIAS}} - V_{\text{RESET}}|$  must be less than specified limit. See [Section 9](#), [Figure 9-1](#), and [Table 9-1](#).
- (6) Tester Conditions for VIH and VIL.
  - Frequency = 60-MHz Maximum Rise Time = 2.5 ns @ (20% – 80%)
  - Frequency = 60-MHz Maximum Fall Time = 2.5 ns @ (80% – 20%)
- (7) PWRDNZ input pin resets the SCP and disables the LVDS receivers. PWRDNZ input pin overrides SCPENZ input pin and tristates the SCPDO output pin.
- (8) The SCP clock is a gated clock. Duty cycle must be  $50\% \pm 10\%$ . The SCP parameter is related to the frequency of DCLK.
- (9) See [Figure 6-2](#).
- (10) See the LVDS Timing Requirements in [Section 6.8](#) and [Figure 6-6](#).
- (11) See [Figure 6-5](#) LVDS Waveform Requirements.
- (12) Simultaneous exposure of the DMD to the maximum [Section 6.4](#) for temperature and UV illumination reduces device lifetime.
- (13) The array temperature cannot be measured directly and must be computed analytically from the temperature measured at test point 1 (TP1) shown in [Figure 7-1](#) and the package thermal resistance [Section 7.6](#).
- (14) Per [Figure 6-1](#), the maximum operational array temperature must be derated based on the micromirror landed duty cycle that the DMD experiences in the end application. See [Section 7.7](#) for a definition of micromirror landed duty cycle.
- (15) Long-term is defined as the usable life of the device.
- (16) Array temperatures beyond those specified as long-term are recommended for short-term conditions only (power-up). Short-term is defined as cumulative time over the usable life of the device and is less than 500 hours.

- (17) Temperature delta is the highest difference between the ceramic test point 1 (TP1) and anywhere on the window edge as shown in Figure 7-1. The window test points TP2, TP3, TP4 and TP5 shown in Figure 7-1 are intended to result in the worst case delta temperature. If a particular application causes another location on the window edge to result in a larger delta temperature, use that location.
- (18) DMD is qualified at the maximum temperature specified. Operation of the DMD outside of these limits has not been tested.
- (19) The average over time (including storage and operating) that the device is not in the elevated dew point temperature range.
- (20) Limit exposure to dew point temperatures in the elevated range during storage and operation to less than a total cumulative time of  $CT_{ELR}$ .
- (21) The maximum marginal ray angle of the incoming illumination light at any point in the micromirror array, including the pond of micromirrors (POM), cannot exceed 55 degrees from the normal to the device array plane. The device window aperture has not necessarily been designed to allow incoming light at higher maximum angles to pass to the micromirrors, and the device performance has not been tested nor qualified at angles exceeding this. Illumination light exceeding this angle outside the micromirror array (including POM) contributes to thermal limitations described in this document, and may negatively affect lifetime.
- (22) The maximum optical power that can be incident on the DMD is limited by the maximum optical power density and the micromirror array temperature.

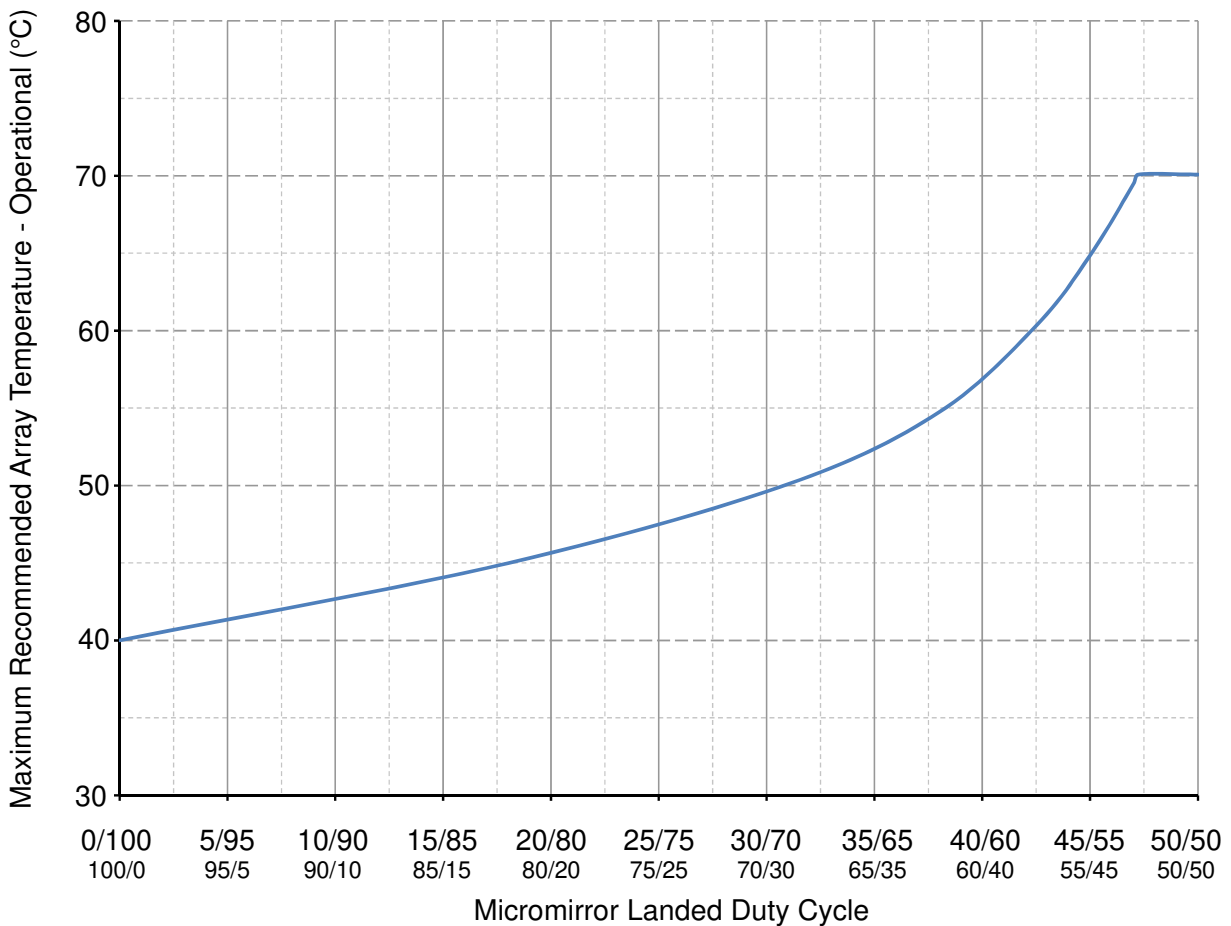

**Figure 6-1. Max Recommended Array Temperature—Derating Curve**

## 6.5 Thermal Information

THERMAL METRIC	DLP670S	UNIT
	FYR Package	
	350 PINS	
Thermal resistance, active area to test point 1 (TP1) <sup>(1)</sup>	0.60	°C/W

- (1) The DMD is designed to conduct absorbed and dissipated heat to the back of the package. The cooling system must be capable of maintaining the package within the temperature range specified in [Section 6.4](#). The total heat load on the DMD is largely driven by the incident light absorbed by the active area; although other contributions include light energy absorbed by the window aperture and electrical power dissipation of the array. Optical systems must be designed to minimize the light energy falling outside the window clear aperture since any additional thermal load in this area can significantly degrade the reliability of the device.

## 6.6 Electrical Characteristics

Over operating free-air temperature range (unless otherwise noted)

PARAMETER	TEST CONDITIONS	MIN	TYP	MAX	UNIT	
<b>OUTPUT VOLTAGES</b>						
V <sub>OH</sub>	High level output voltage	V <sub>CC</sub> = 1.8 V, I <sub>OH</sub> = -2 mA		0.8 × V <sub>CC</sub>	V	
V <sub>OL</sub>	Low level output voltage	V <sub>CC</sub> = 1.95 V, I <sub>OL</sub> = 2 mA		0.2 × V <sub>CC</sub>	V	
<b>CURRENTS</b>						
I <sub>OZ</sub>	High impedance output current	V <sub>CC</sub> = 1.95 V		-40	25	μA
I <sub>IL</sub>	Low level input current	V <sub>CC</sub> = 1.95 V, V <sub>I</sub> = 0		-1		μA
I <sub>IH</sub>	High level input current <sup>(1)</sup>	V <sub>CC</sub> = 1.95 V, V <sub>I</sub> = V <sub>CC</sub>			110	μA
I <sub>CC</sub>	Supply current VCC	V <sub>CC</sub> = 1.95 V			1200	mA
I <sub>CCI</sub>	Supply current VCCI	V <sub>CCI</sub> = 1.95 V			330	mA
I <sub>OFFSET</sub>	Supply current VOFFSET <sup>(2)</sup>	V <sub>OFFSET</sub> = 10.5 V			13	mA
I <sub>BIAS</sub>	Supply current VBIAS <sup>(2) (3)</sup>	V <sub>BIAS</sub> = 18.5 V			-4	mA
I <sub>RESET</sub>	Supply current VRESET <sup>(3)</sup>	V <sub>RESET</sub> = -14.5 V			9	mA
<b>SUPPLY POWER</b>						
P <sub>TOTAL</sub>	Total Supply Power Dissipation				3320	mW

- (1) Applies to LVCMOS pins only. Excludes LVDS pins and test pad pins.  
(2) To prevent excess current, the supply voltage delta |V<sub>BIAS</sub> – V<sub>OFFSET</sub>| must be less than the specified limit in [Section 6.4](#).  
(3) To prevent excess current, the supply voltage delta |V<sub>BIAS</sub> – V<sub>RESET</sub>| must be less than specified limit in [Section 6.4](#).

## 6.7 Capacitance at Recommended Operating Conditions

over operating free-air temperature range (unless otherwise noted)

PARAMETER	TEST CONDITIONS	MIN	TYP	MAX	UNIT
C <sub>I_lvds</sub>	LVDS Input Capacitance 2xLVDS	f = 1 MHz		20	pF
C <sub>I_nonlvds</sub>	Non-LVDS Input capacitance	f = 1 MHz		20	pF
C <sub>I_tdiode</sub>	Temp Diode Input capacitance	f = 1 MHz		30	pF
C <sub>O</sub>	Output Capacitance	f = 1 MHz		20	pF

## 6.8 Timing Requirements

			MIN	NOM	MAX	UNIT
<b>SCP<sup>(1)</sup></b>						
$t_r$	Rise time	20% to 80% reference points			30	ns
$t_f$	Fall time	80% to 20% reference points			30	ns
<b>LVDS<sup>(2)</sup></b>						
$t_r$	Rise slew rate	20% to 80% reference points	0.7	1		V/ns
$t_f$	Fall slew rate	80% to 20% reference points	0.7	1		V/ns
$t_C$	Clock Cycle	DCLK_A, LVDS pair	2.5			ns
$t_C$	Clock Cycle	DCLK_B, LVDS pair	2.5			ns
$t_C$	Clock Cycle	DCLK_C, LVDS pair	2.5			ns
$t_C$	Clock Cycle	DCLK_D, LVDS pair	2.5			ns
$t_W$	Pulse Width	DCLK_A LVDS pair	1.19	1.25		ns
$t_W$	Pulse Width	DCLK_B LVDS pair	1.19	1.25		ns
$t_W$	Pulse Width	DCLK_C LVDS pair	1.19	1.25		ns
$t_W$	Pulse Width	DCLK_D LVDS pair	1.19	1.25		ns
$t_{Su}$	Setup Time	D_A(15:0) before DCLK_A, LVDS pair	0.325			ns
$t_{Su}$	Setup Time	D_B(15:0) before DCLK_B, LVDS pair	0.325			ns
$t_{Su}$	Setup Time	D_C(15:0) before DCLK_C, LVDS pair	0.325			ns
$t_{Su}$	Setup Time	D_D(15:0) before DCLK_D, LVDS pair	0.325			ns
$t_{Su}$	Setup Time	SCTRL_A before DCLK_A, LVDS pair	0.325			ns
$t_{Su}$	Setup Time	SCTRL_B before DCLK_B, LVDS pair	0.325			ns
$t_{Su}$	Setup Time	SCTRL_C before DCLK_C, LVDS pair	0.325			ns
$t_{Su}$	Setup Time	SCTRL_D before DCLK_D, LVDS pair	0.325			ns
$t_h$	Hold Time	D_A(15:0) after DCLK_A, LVDS pair	0.145			ns
$t_h$	Hold Time	D_B(15:0) after DCLK_B, LVDS pair	0.145			ns
$t_h$	Hold Time	D_C(15:0) after DCLK_C, LVDS pair	0.145			ns
$t_h$	Hold Time	D_D(15:0) after DCLK_D, LVDS pair	0.145			ns
$t_h$	Hold Time	SCTRL_A after DCLK_A, LVDS pair	0.145			ns
$t_h$	Hold Time	SCTRL_B after DCLK_B, LVDS pair	0.145			ns
$t_h$	Hold Time	SCTRL_C after DCLK_C, LVDS pair	0.145			ns
$t_h$	Hold Time	SCTRL_D after DCLK_D, LVDS pair	0.145			ns
<b>LVDS<sup>(2)</sup></b>						
$t_{SKEW}$	Skew Time	Channel B relative to Channel A <sup>(3)</sup> <sup>(4)</sup> , LVDS pair	-1.25		+1.25	ns
$t_{SKEW}$	Skew Time	Channel D relative to Channel C <sup>(5)</sup> <sup>(6)</sup> , LVDS pair	-1.25		+1.25	ns

(1) See [Figure 6-3](#) for Rise Time and Fall Time for SCP.

(2) See [Figure 6-5](#) for Timing Requirements for LVDS.

(3) Channel A (Bus A) includes the following LVDS pairs: DCLK\_AN and DCLK\_AP, SCTRL\_AN and SCTRL\_AP, D\_AN(15:0) and D\_AP(15:0).

(4) Channel B (Bus B) includes the following LVDS pairs: DCLK\_BN and DCLK\_BP, SCTRL\_BN and SCTRL\_BP, D\_BN(15:0) and D\_BP(15:0).

(5) Channel C (Bus C) includes the following LVDS pairs: DCLK\_CN and DCLK\_CP, SCTRL\_CN and SCTRL\_CP, D\_CN(15:0) and D\_CP(15:0).

(6) Channel D (Bus D) includes the following LVDS pairs: DCLK\_DN and DCLK\_DP, SCTRL\_DN and SCTRL\_DP, D\_DN(15:0) and D\_DP(15:0).

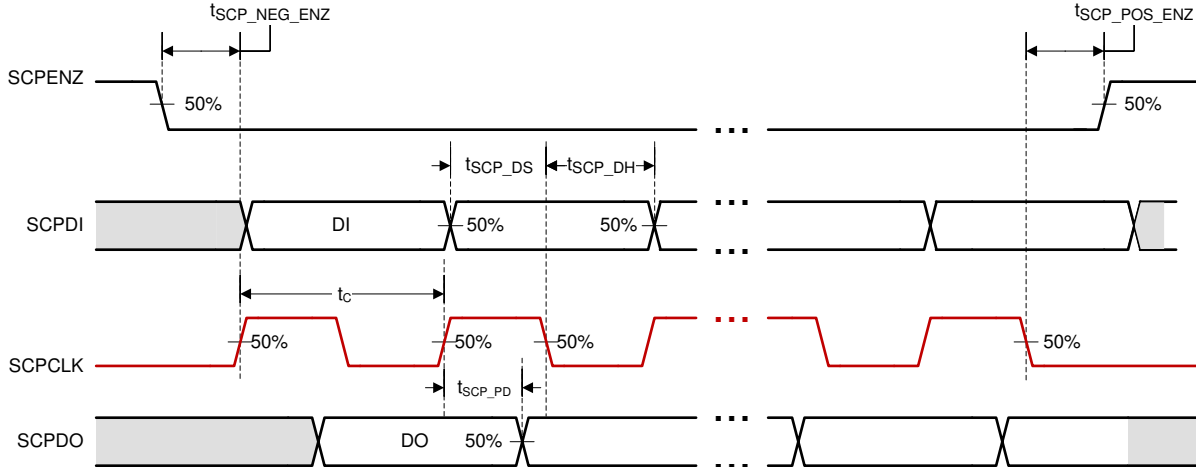
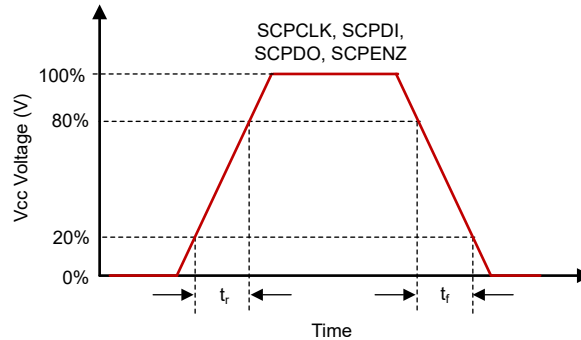

**Figure 6-2. SCP Timing Requirements**

- A. See [Section 6.4](#) for f<sub>SCPCLK</sub>, t<sub>SCP\_DS</sub>, t<sub>SCP\_DH</sub> and t<sub>SCP\_PD</sub> specifications.
- B. SCPCLK falling-edge capture for SCPDI.
- C. SCPCLK rising-edge launch for SCPDO.
- D. See [Equation 1](#).

$$f_{SCPCLK} = \frac{1}{t_C}$$

(1)



**Figure 6-3. SCP Requirements for Rise and Fall**

See [Section 6.8](#) for t<sub>r</sub> and t<sub>f</sub> specifications and conditions.

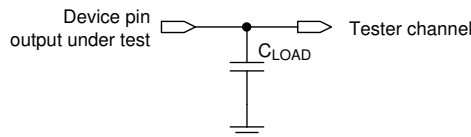

**Figure 6-4. Test Load Circuit for Output Propagation Measurement**

For output timing analysis, the tester pin electronics and its transmission line effects must be taken into account. System designers must use IBIS or other simulation tools to correlate the timing reference load to a system environment.

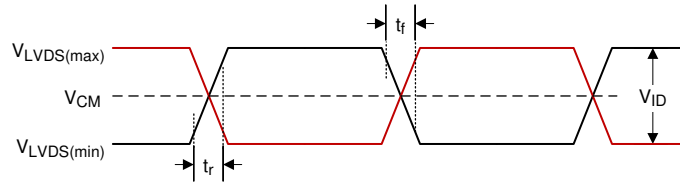

A. See [Equation 2](#) and [Equation 3](#).

**Figure 6-5. LVDS Waveform Requirements**

$$V_{LVDS(max)} = V_{CM(max)} + \left| \frac{1}{2} \times V_{ID(max)} \right| \quad (2)$$

$$V_{LVDS(min)} = V_{CM(min)} - \left| \frac{1}{2} \times V_{ID(max)} \right| \quad (3)$$

See [Section 6.4](#) for  $V_{CM}$ ,  $V_{ID}$ , and  $V_{LVDS}$  specifications and conditions.

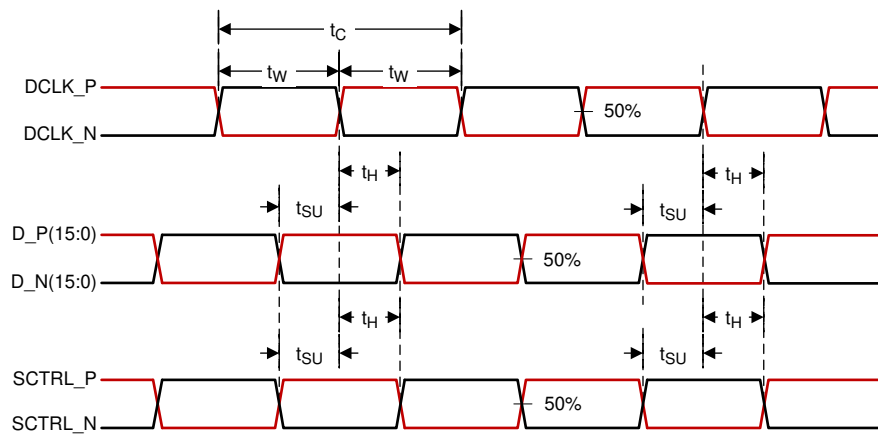

**Figure 6-6. Timing Requirements**

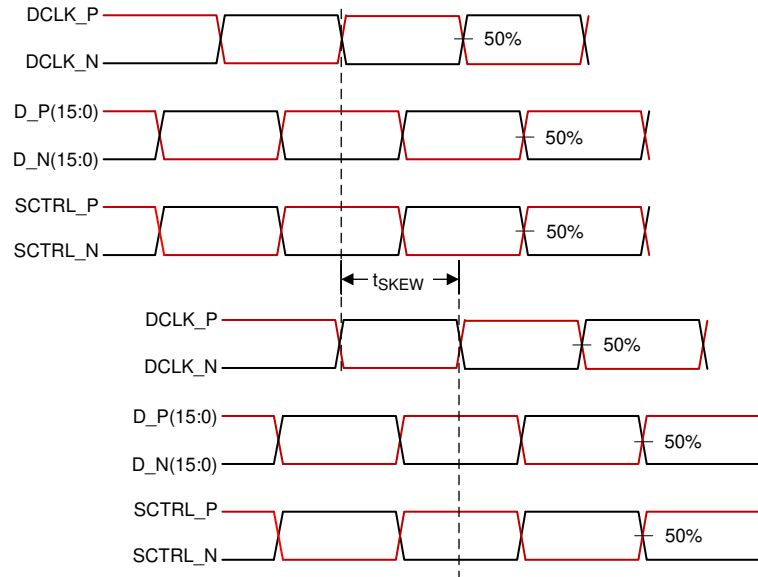

**Figure 6-7. LVDS Interface Channel Skew Definition**

See [Section 6.8](#) for timing requirements and LVDS pairs per channel (bus) defining D\_P(15:0) and D\_N(15:0).

### 6.9 Typical Characteristics

When the DMD is controlled by the DLPC900, the digital controller has four modes of operation:

- A. Video mode
- B. Video pattern mode
- C. Pre-stored pattern mode
- D. Pattern on-the-fly mode

In video mode (A), the 24-bit frames displayed on the DMD are the same as the 24-bit video input source and frame rates. In video pattern mode (B), the  $V_{SYNC}$  rates displayed on the DMD are linked to the incoming video source  $V_{SYNC}$  rates but the overall pattern rates depend upon the configured bit depth. In modes B, C, and D, the pattern rates depend on the bit depth as shown in [Table 6-1](#).

**Table 6-1. DLP670S Pattern Rate versus Bit Depth using DLPC900**

BIT DEPTH	VIDEO PATTERN MODE (Hz)	PRE-STORED or PATTERN ON-THE-FLY MODE (Hz)
1	2880	9523
2	1440	2915
3	960	2283
4	720	1302
5	480	769
6	480	672
7	360	500
8	247	247

### 6.10 System Mounting Interface Loads

**Table 6-2. System Mounting Interface Loads**

PARAMETER	MIN	NOM	MAX	UNIT
<b>When loads are applied to the electrical and thermal interface area</b>				
Maximum load to be applied to the electrical interface area <sup>(1)</sup>			111	N

**Table 6-2. System Mounting Interface Loads (continued)**

PARAMETER	MIN	NOM	MAX	UNIT
Maximum load to be applied to the thermal interface area <sup>(1)</sup>			111	N
<b>When a load is applied to only the electrical interface area</b>				
Maximum load to be applied to the electrical interface area <sup>(1)</sup>			222	N
Maximum load to be applied to the thermal interface area <sup>(1)</sup>			0	N

(1) Apply the load uniformly in the corresponding areas shown in Figure 6-8.

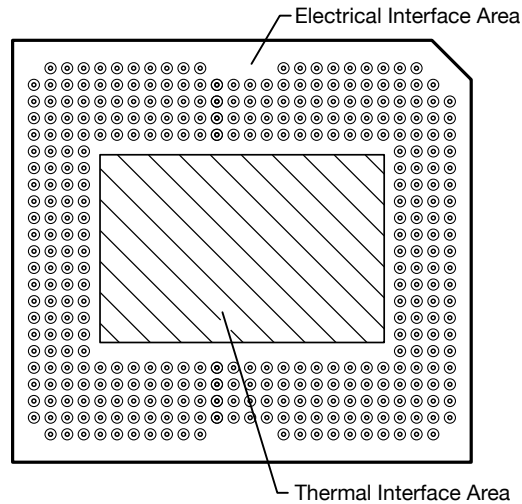

**Figure 6-8. System Mounting Interface Loads**

## 6.11 Micromirror Array Physical Characteristics

**Table 6-3. Micromirror Array Physical Characteristics**

PARAMETER DESCRIPTION	VALUE	UNIT
Number of active columns <sup>(1)</sup>	M	2716 micromirrors
Number of active rows <sup>(1)</sup>	N	1600 micromirrors
Micromirror (pixel) pitch <sup>(1)</sup>	P	5.4 μm
Micromirror active array width <sup>(1)</sup>	Micromirror pitch × number of active columns	14.6664 mm
Micromirror active array height <sup>(1)</sup>	Micromirror pitch × number of active rows	8.6400 mm
Micromirror active border (All four sides) <sup>(2)</sup>	Pond of micromirrors (POM)	20 micromirrors / side

(1) See Figure 6-9.

(2) The structure and qualities of the border around the active array includes a band of partially functional micromirrors referred to as the pond of mirrors (POM). These micromirrors are structurally and electrically prevented from tilting toward the bright or ON state but still require an electrical bias to tilt toward the OFF state.

Off-State  
Light Path

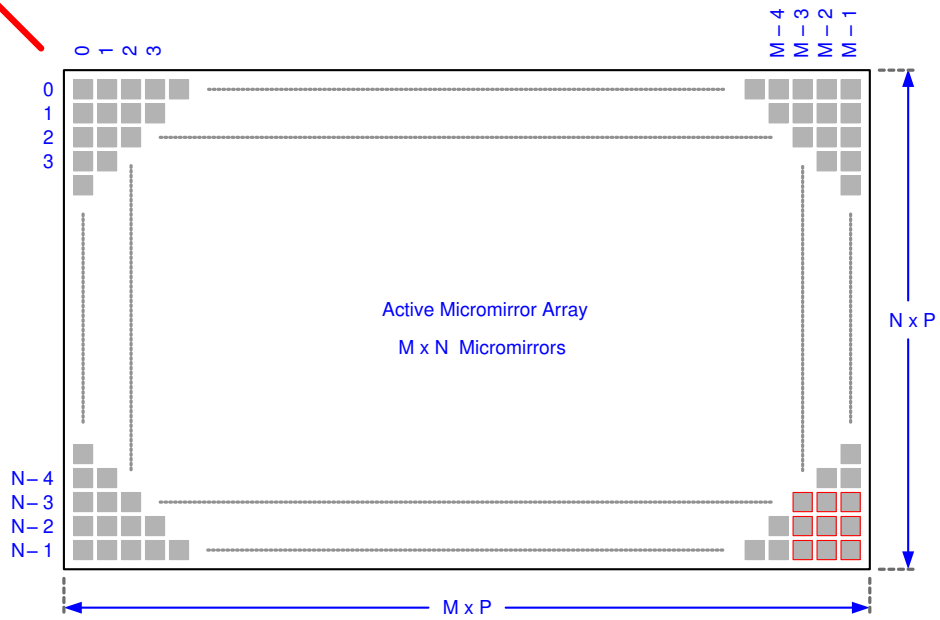

Incident  
Illumination  
Light Path

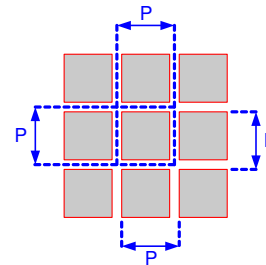

Pond Of Micromirrors (POM) omitted for clarity.  
Details omitted for clarity. Not to scale.

**Figure 6-9. Micromirror Array Physical Characteristics**

Refer to [Section 6.11](#) table for M, N, and P specifications.

## 6.12 Micromirror Array Optical Characteristics

**Table 6-4. Micromirror Array Optical Characteristics**

PARAMETER	TEST CONDITION	MIN	NOM	MAX	UNIT
Mirror tilt angle <sup>(1) (2) (3) (4)</sup>	Landed State	15.6	17.5	18.4	degrees
Micromirror crossover time <sup>(5)</sup>	Typical Performance		1	3	μS
Micromirror switching time <sup>(6)</sup>	Typical Performance	10			
Number of out-of-specification micromirrors <sup>(7)</sup>	Adjacent micromirrors			0	micromirrors
	Non-Adjacent micromirrors			10	
DMD Photopic Efficiency <sup>(8)</sup>	420 nm – 700 nm		65%		

- (1) Measured relative to the plane formed by the overall micromirror array
- (2) Represents the variation that can occur between any two individual micromirrors, located on the same device or located on different devices.
- (3) For some applications, it is critical to account for the micromirror tilt angle variation in the overall system optical design. With some system optical designs, the micromirror tilt angle variation within a device may result in perceivable nonuniformities in the light field reflected from the micromirror array. With some system optical designs, the micromirror tilt angle variation between devices may result in colorimetry variations, system efficiency variations, system contrast variations, and optical power variations.
- (4) When the micromirror array is landed (not parked), the tilt direction of each individual micromirror is dictated by the binary contents of the CMOS memory cell associated with each individual micromirror. A binary value of 1 results in a micromirror landing in the ON State direction. A binary value of 0 results in a micromirror landing in the OFF State direction. See [Figure 6-10](#).
- (5) The time required for a micromirror to nominally transition from one landed state to the opposite landed state.
- (6) The minimum time between successive transitions of a micromirror.
- (7) An out-of-specification micromirror is defined as a micromirror that is unable to transition between the two landed states within the specified micromirror switching time.
- (8) Efficiency numbers assume 35-degree illumination angle, F/2.4 illumination and collection cones, uniform source spectrum, and uniform pupil illumination.
  - Window Transmission 94% (double Pass, Through Two Window Surfaces)
  - Micromirror Reflectivity 88%
  - Array Diffraction Efficiency 84% (@f/2.4)
  - Array Fill Factor 93%

Efficiency numbers assume 100% electronic mirror duty cycle and do not include optical overfill loss. Note that this number is specified under conditions described above and deviations from the specified conditions result in decreased efficiency.

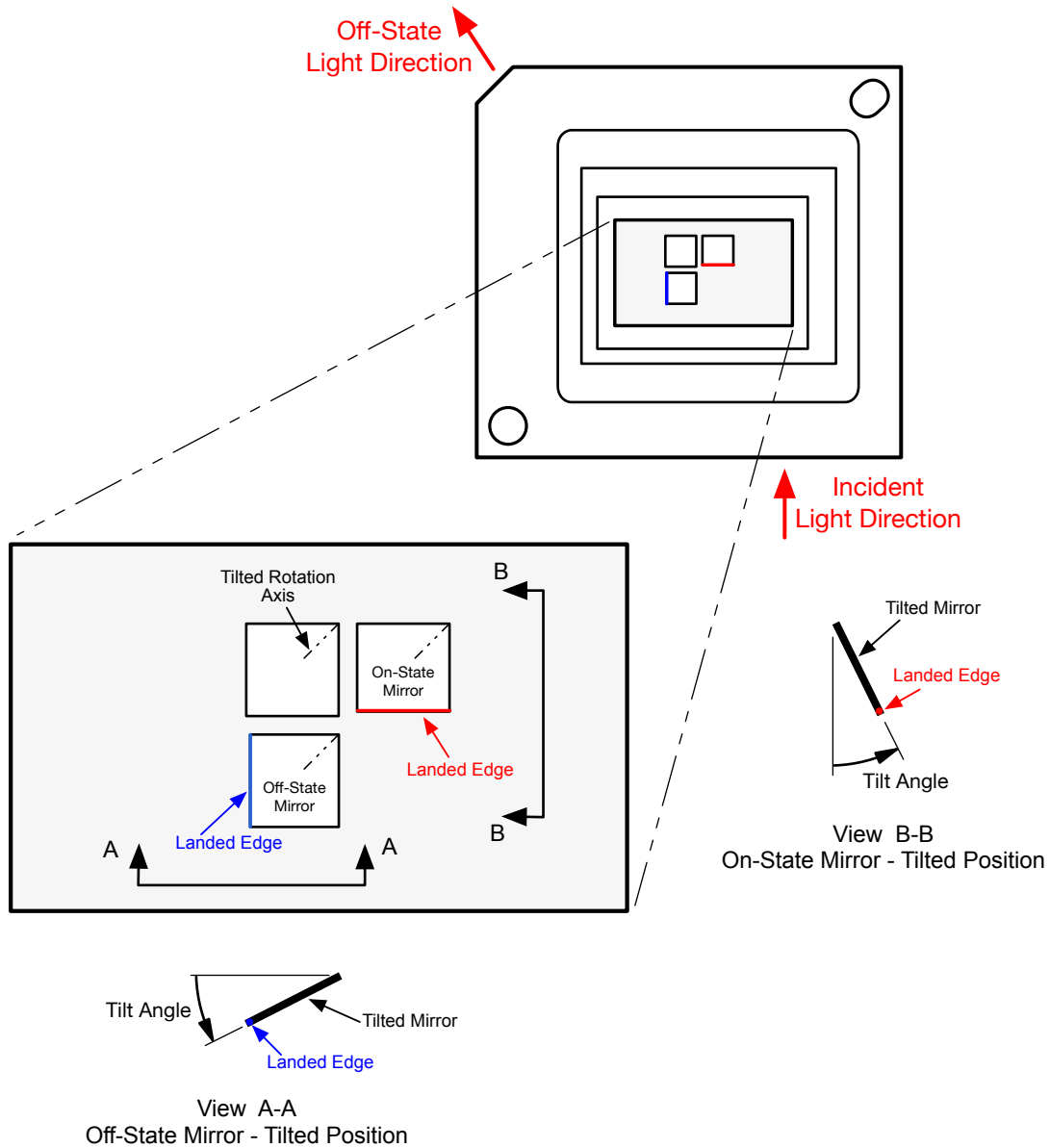

**Figure 6-10. Micromirror Landed Orientation and Tilt**

## 6.13 Window Characteristics

**Table 6-5. DMD Window Characteristics**

PARAMETER <sup>(1)</sup>	CONDITIONS	MIN	NOM	MAX	UNIT
Window material	Corning Eagle XG				
Window refractive index	at wavelength 546.1 nm		1.5119		
Window aperture	See Note <sup>(2)</sup>				
Illumination overfill	Refer to <a href="#">Section 7.5.3</a>				
Window transmittance, single-pass through both surfaces and glass <sup>(3)</sup>	Minimum within the wavelength range 420 nm to 680 nm. Applies to all angles 0° to 30° AOI.	97%			
	Average over the wavelength range 420 nm to 680 nm. Applies to all angles 30° to 45° AOI.	97%			

- (1) See [Section 7.5](#) for more information.  
(2) For details on the size and location of the window aperture, see the Mechanical ICD in the Mechanical, Packaging, and Orderable Information section of this data sheet.  
(3) See the TI [Wavelength Transmittance Considerations for DLP® DMD Window Application Note](#).

## 6.14 Chipset Component Usage Specification

Reliable function and operation of the DLP670S DMD requires that it be used in conjunction with the other components of the applicable DLP chipset, including those components that contain or implement TI DMD control technology. TI DMD control technology is the TI technology and devices for operating or controlling a DLP DMD.

## 7 Detailed Description

### 7.1 Overview

The DLP670S DMD is a 0.67-inch diagonal spatial light modulator which consists of an array of highly reflective aluminum micromirrors. The DMD is an electrical input, optical output micro-electrical-mechanical system (MEMS). The input data electrical interface is Low Voltage Differential Signaling (LVDS). The DMD consists of a two-dimensional array of 1-bit CMOS memory cells. The array is organized in a grid of M memory cell columns by N memory cell rows. Refer to the [Section 7.2](#). The positive or negative deflection angle of the micromirrors can be individually controlled by changing the address voltage of underlying CMOS addressing circuitry and micromirror reset signals (MBRST).

The DMD is one part of a chipset comprising of the DLP670S DMD and the DLPC900 Controller. To ensure reliable operation, the DLPC900 Controller must always be used to control the DLP670S DMD.

### 7.2 Functional Block Diagram

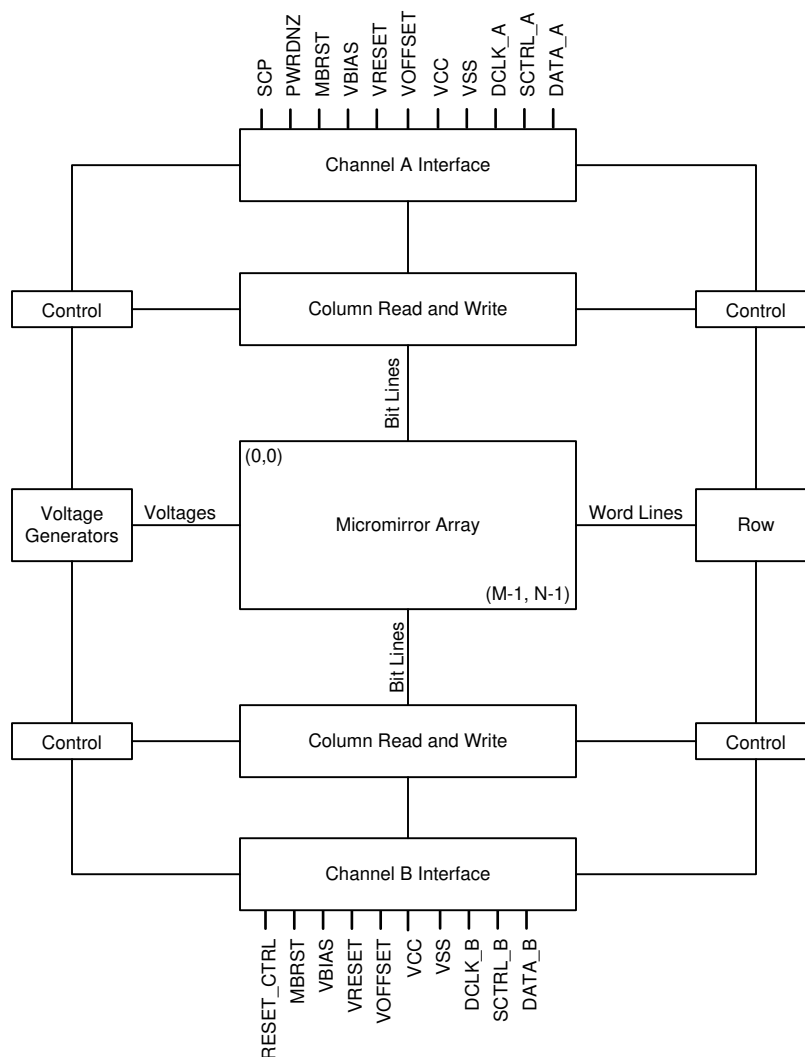

Channels C and D not shown. For pin details on Channels A, B, C, and D, refer to [Section 5](#) and LVDS Interface section of [Section 6.8](#). RESET\_CTRL is used in applications when an external reset signal is required.

## 7.3 Feature Description

### 7.3.1 Power Interface

The DMD requires five DC voltages: DMD\_P3P3V, DMD\_P1P8V, VOFFSET, VRESET, and VBIAS. DMD\_P3P3V is a filtered version of the 3.3-V (P3P3V) supply received over the cables from the DLPC900 Controller Board. DMD\_P3P3V is used on the DMD Board to create the other DMD voltages (DMD\_P1P8V, VOFFSET, VRESET, and VBIAS) required for proper DMD operation. TI provides a DMD board reference design on TI.com to enable customers to see how these voltages are created as well and how the DMD board design is accomplished.

### 7.3.2 Timing

The data sheet provides timing at the device pin. For output timing analysis, the tester pin electronics and its transmission line effects must be considered. [Figure 6-4](#) shows an equivalent test load circuit for the output under test. Timing reference loads are not intended as a precise representation of any particular system environment or depiction of the actual load presented by a production test. System designers must use IBIS or other simulation tools to correlate the timing reference load to a system environment. The load capacitance value stated is only for characterization and measurement of AC timing signals. This load capacitance value does not indicate the maximum load the device is capable of driving.

## 7.4 Device Functional Modes

DMD functional modes are controlled by the DLPC900 Controller. See the DLPC900 Controller data sheet or contact a TI applications engineer.

## 7.5 Optical Interface and System Image Quality

---

### Note

TI assumes no responsibility for image quality artifacts or DMD failures caused by optical system operating conditions exceeding limits described previously.

---

TI assumes no responsibility for end-equipment optical performance. Achieving the desired end-equipment optical performance involves making trade-offs between numerous component and system design parameters. Optimizing system optical performance and image quality strongly relate to optical system design parameter trades. Although it is not possible to anticipate every conceivable application, the projected image quality and the optical performance are contingent on compliance to the optical system operating conditions described in the following sections.

### 7.5.1 Numerical Aperture and Stray Light Control

The angle defined by the numerical aperture of the illumination and projection optics at the DMD optical area needs to be the same. This angle cannot exceed the nominal device micromirror tilt angle unless appropriate apertures are added in the illumination and projection pupils to block out flat-state and stray light from the projection lens. The micromirror tilt angle defines DMD capability to separate the "ON" optical path from any other light path, including undesirable flat-state specular reflections from the DMD window, DMD border structures, or other system surfaces near the DMD such as prism or lens surfaces. If the numerical aperture exceeds the micromirror tilt angle, or if the projection numerical aperture angle is more than two degrees larger than the illumination numerical aperture angle, objectionable artifacts may occur in the projected image border region or active area.

### 7.5.2 Pupil Match

TI's optical and image quality specifications assume that the exit pupil of the illumination optics is nominally centered within 2° of the entrance pupil of the projection optics. Misalignment of pupils can create objectionable artifacts in the projected image's border region and active area, which may require additional system apertures to control, especially if the numerical aperture of the system exceeds the pixel tilt angle.

### 7.5.3 Illumination Overfill

The active area of the device is surrounded by an aperture on the inside DMD window surface that masks structures of the DMD chip assembly from normal view, and is sized to anticipate several optical operating conditions. Overfill light illuminating the window aperture can create reflections from the edge of the window aperture opening that may corrupt the intended projected image. Design the illumination optical system to limit light flux incident anywhere on the window aperture from exceeding approximately 10% of the average flux level in the active area. Depending on the particular system optical architecture, overfill light may have to be further reduced below the suggested 10% level in order for the projected image to be acceptable.

### 7.6 Micromirror Array Temperature Calculation

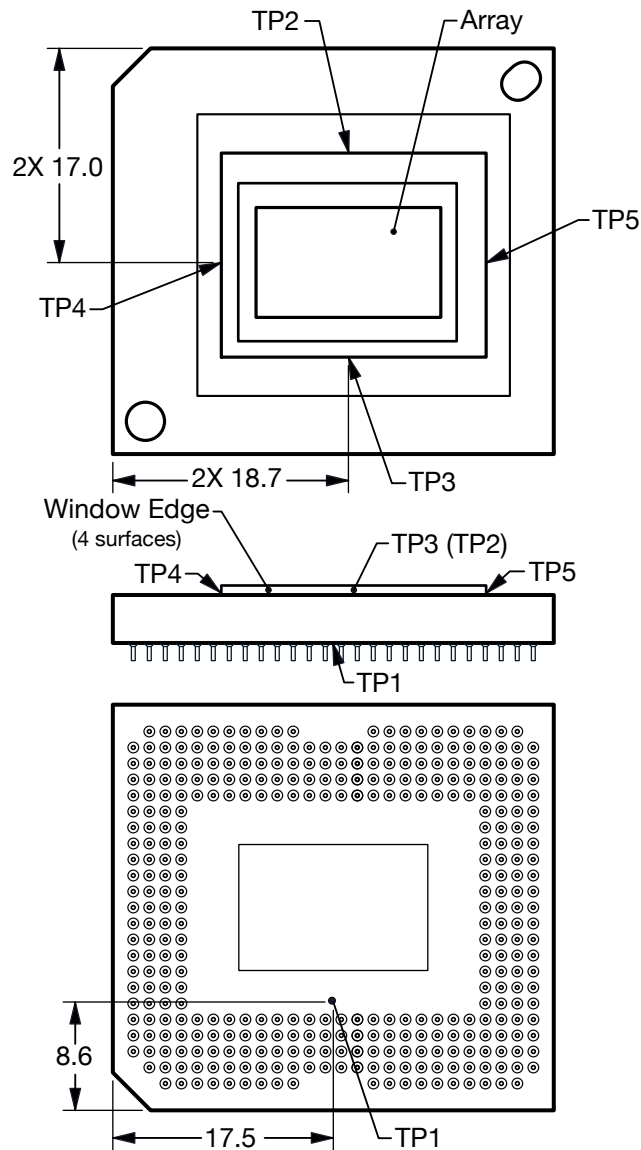

Figure 7-1. DMD Thermal Test Points

Micromirror array temperature can be computed analytically from measurement points on the outside of the package, the package thermal resistance, the electrical power, and the illumination heat load. The relationship between micromirror array temperature and the reference ceramic temperature is provided by the following equations:

$$T_{\text{ARRAY}} = T_{\text{CERAMIC}} + (Q_{\text{ARRAY}} \times R_{\text{ARRAY-TO-CERAMIC}})$$

$$Q_{\text{ARRAY}} = Q_{\text{ELECTRICAL}} + Q_{\text{ILLUMINATION}}$$

where

- $T_{\text{ARRAY}}$  = Computed array temperature (°C)
- $T_{\text{CERAMIC}}$  = Measured ceramic temperature (°C) (measured at TP1 location)
- $R_{\text{ARRAY-TO-CERAMIC}}$  = Thermal resistance of package specified in [Thermal Information](#) from array to ceramic TP1 (°C/Watt)
- $Q_{\text{ARRAY}}$  = Total DMD power on the array (W) (electrical + absorbed)
- $Q_{\text{ELECTRICAL}}$  = Nominal electrical power (W)
- $Q_{\text{ILLUMINATION}}$  = Illumination power absorbed (W)

The electrical power dissipation of the DMD is variable and depends on the voltages, data rates, and operating frequencies. A nominal electrical power dissipation to use when calculating array temperature is 3.32 W. The absorbed power from the illumination source is variable and depends on the operating state of the micromirrors and the intensity of the light source. The factors used in determining the illumination power absorbed is shown in each of the examples below. Examples are included where the optical power has been determined by measuring the illumination power density, total illumination power, and screen lumens. The examples assume illumination distribution is 83.7% on the active array and 16.3% on the area outside the array.

### 7.6.1 Micromirror Array Temperature Calculation using Illumination Power Density

The equations below are valid for each DMD in a single chip or multi-chip DMD system.

- $Q_{\text{ILLUMINATION}} = (Q_{\text{INCIDENT}} \times \text{DMD average thermal absorptivity})$  (W)
- $Q_{\text{INCIDENT}} = \text{ILL}_{\text{DENSITY}} \times \text{ILL}_{\text{AREA}}$  (W)
- $\text{ILL}_{\text{DENSITY}}$  = measured illumination optical power density at DMD (W/cm<sup>2</sup>)
- $\text{ILL}_{\text{AREA}}$  = illumination area on DMD (cm<sup>2</sup>)
- DMD average thermal absorptivity = 0.40

$$Q_{\text{ELECTRICAL}} = 3.32 \text{ W}$$

$$\text{Array size} = 14.6664 \text{ mm} \times 8.6400 \text{ mm} = 1.267 \text{ cm}^2$$

$$\text{ILL}_{\text{DENSITY}} = 31 \text{ W/cm}^2 \text{ (measured)}$$

$$T_{\text{CERAMIC}} = 50.0 \text{ }^\circ\text{C} \text{ (measured)}$$

$$\text{ILL}_{\text{AREA}} = 1.267 \text{ cm}^2 / (83.7\%) = 1.512 \text{ cm}^2$$

$$Q_{\text{INCIDENT}} = 31 \text{ W/cm}^2 \times 1.512 \text{ cm}^2 = 46.9 \text{ W}$$

$$Q_{\text{ARRAY}} = 3.32 \text{ W} + (46.9 \text{ W} \times 0.40) = 22.1 \text{ W}$$

$$T_{\text{ARRAY}} = 50.0 \text{ }^\circ\text{C} + (22.1 \text{ W} \times 0.60 \text{ }^\circ\text{C/W}) = 63.3 \text{ }^\circ\text{C}$$

### 7.6.2 Micromirror Array Temperature Calculation using Total Illumination Power

The equations below are valid for each DMD in a single chip or multi-chip DMD system.

- $Q_{\text{ILLUMINATION}} = (Q_{\text{INCIDENT}} \times \text{DMD average thermal absorptivity})$  (W)
- $Q_{\text{INCIDENT}}$  = measured total illumination optical power at DMD (W)
- DMD average thermal absorptivity = 0.40

$$Q_{\text{ELECTRICAL}} = 3.32 \text{ W}$$

$$Q_{\text{INCIDENT}} = 46.9 \text{ W (measured)}$$

$$T_{\text{CERAMIC}} = 50.0 \text{ }^{\circ}\text{C (measured)}$$

$$Q_{\text{ARRAY}} = 3.32 \text{ W} + (46.9 \text{ W} \times 0.40) = 22.1 \text{ W}$$

$$T_{\text{ARRAY}} = 50.0 \text{ }^{\circ}\text{C} + (22.1 \text{ W} \times 0.60 \text{ }^{\circ}\text{C/W}) = 63.3 \text{ }^{\circ}\text{C}$$

### 7.6.3 Micromirror Array Temperature Calculation using Screen Lumens

The equations below are valid for a single chip DMD system with spectral efficiency of 300 lumens/Watt.

- $Q_{\text{ILLUMINATION}} = \text{SL} \times C_{\text{L2W}}$  (W)
- SL = measured ANSI screen lumens (lm)
- $C_{\text{L2W}}$  = Conversion constant for screen lumens to power absorbed on DMD (Watts/Lumen)

$$Q_{\text{ELECTRICAL}} = 3.32 \text{ W}$$

$$C_{\text{L2W}} = 0.00266 \text{ W/lm}$$

$$\text{SL} = 7000 \text{ lm (measured)}$$

$$T_{\text{CERAMIC}} = 50.0 \text{ }^{\circ}\text{C (measured)}$$

$$Q_{\text{ARRAY}} = 3.32 \text{ W} + (0.00266 \text{ W/lm} \times 7000 \text{ lm}) = 21.94 \text{ W}$$

$$T_{\text{ARRAY}} = 50.0 \text{ }^{\circ}\text{C} + (21.94 \text{ W} \times 0.60 \text{ }^{\circ}\text{C/W}) = 63.2 \text{ }^{\circ}\text{C}$$

## 7.7 Micromirror Landed-On/Landed-Off Duty Cycle

### 7.7.1 Definition of Micromirror Landed-On/Landed-Off Duty Cycle

The micromirror landed-on/landed-off duty cycle (landed duty cycle) denotes the amount of time (as a percentage) that an individual micromirror is landed in the On state versus the amount of time the same micromirror is landed in the Off state.

As an example, a landed duty cycle of 100/0 indicates that the referenced pixel is in the On state 100% of the time and in the Off state 0% of the time. Additionally, a landed duty cycle of 0/100 indicates that the pixel is in the Off state 100% of the time and in the On state 0% of the time. Likewise, 50/50 indicates that the pixel is On 50% of the time and Off 50% of the time.

---

#### Note

When assessing landed duty cycle, the time spent switching from one state (ON or OFF) to the other state (OFF or ON) is considered negligible and is thus ignored.

---

Since a micromirror can only be landed in one state or the other (On or Off), the two numbers (percentages) always add to 100.

### 7.7.2 Landed Duty Cycle and Useful Life of the DMD

Knowing the long-term average landed duty cycle (of the end product or application) is important because subjecting all (or a portion) of the DMD micromirror array (also called the active array) to an asymmetric landed duty cycle for a prolonged period of time can reduce the DMD usable life.

Note that it is the symmetry or asymmetry of the landed duty cycle that is of relevance. The symmetry of the landed duty cycle is determined by how close the two numbers (percentages) are to being equal. For example, a landed duty cycle of 50/50 is perfectly symmetrical whereas a landed duty cycle of 100/0 or 0/100 is perfectly asymmetrical.

### 7.7.3 Landed Duty Cycle and Operational DMD Temperature

Operational DMD temperature and landed duty cycle interact to affect the DMD usable life, and this interaction can be exploited to reduce the impact that an asymmetrical landed duty cycle has on the DMD usable life. This is quantified in the derating curve shown in [Figure 6-1](#). The importance of this curve is that:

- All points along this curve represent the same usable life.
- All points above this curve represent lower usable life (and the further away from the curve, the lower the usable life).
- All points below this curve represent higher usable life (and the further away from the curve, the higher the usable life).

In practice, this curve specifies the maximum operating DMD temperature that the DMD operates at for a given long-term average landed duty cycle.

### 7.7.4 Estimating the Long-Term Average Landed Duty Cycle of a Product or Application

During a given period of time, the Landed Duty Cycle of a given pixel follows from the input image content being displayed by that specific pixel regardless if the illumination is turned on or off.

For example, in the simplest case, when displaying pure-white on a given pixel for a given time period, that pixel experiences a 100/0 Landed Duty Cycle during that time period. Likewise, when displaying pure-black, the pixel experiences a 0/100 Landed Duty Cycle.

If the use case involves inputting grayscale (8-bit) input images, between the two extremes (ignoring for the moment color and any image processing that may be applied to an incoming image), the Landed Duty Cycle tracks one-to-one with the grayscale value, as shown in [Table 7-1](#).

**Table 7-1. Grayscale Value and Landed Duty Cycle**

Grayscale Value	Landed Duty Cycle
0%	0/100
10%	10/90
20%	20/80
30%	30/70
40%	40/60
50%	50/50
60%	60/40
70%	70/30
80%	80/20
90%	90/10
100%	100/0

Accounting for color rendition (but still ignoring image processing) requires knowing both the color intensity (from 0% to 100%) for each constituent primary color (red, green, and blue) for the given pixel as well as the color cycle time for each primary color, where “color cycle time” is the total percentage of the frame time that a given primary must be displayed in order to achieve the desired white point.

During a given period of time, the landed duty cycle of a given pixel can be calculated as follows:

- Landed Duty Cycle = (Red\_Cycle\_% × Red\_Scale\_Value) + (Green\_Cycle\_% × Green\_Scale\_Value) + (Blue\_Cycle\_% × Blue\_Scale\_Value)

Where

- Red\_Cycle\_%, Green\_Cycle\_%, and Blue\_Cycle\_%, represent the percentage of the frame time that Red, Green, and Blue are displayed (respectively) to achieve the desired white point. (1)

For example, assume that the red, green, and blue color cycle times are 50%, 20%, and 30% respectively (in order to achieve the desired white point), then the Landed Duty Cycle for various combinations of red, green, blue color intensities are as shown in [Table 7-2](#) and [Table 7-3](#).

**Table 7-2. Example Landed Duty Cycle for Full-Color, Color Percentage**

Red Cycle Percentage	Green Cycle Percentage	Blue Cycle Percentage
50%	20%	30%

**Table 7-3. Example Landed Duty Cycle for Full-Color**

Red Scale Value	Green Scale Value	Blue Scale Value	Landed Duty Cycle
0%	0%	0%	0/100
100%	0%	0%	50/50
0%	100%	0%	20/80
0%	0%	100%	30/70
12%	0%	0%	6/94
0%	35%	0%	7/93
0%	0%	60%	18/82
100%	100%	0%	70/30
0%	100%	100%	50/50
100%	0%	100%	80/20
12%	35%	0%	13/87
0%	35%	60%	25/75
12%	0%	60%	24/76
100%	100%	100%	100/0

## 8 Application and Implementation

---

### Note

Information in the following applications sections is not part of the TI component specification, and TI does not warrant its accuracy or completeness. TI's customers are responsible for determining suitability of components for their purposes, as well as validating and testing their design implementation to confirm system functionality.

---

### 8.1 Application Information

The DMD is a spatial light modulator, which reflects incoming light from an illumination source to one of two directions, with the primary direction being into a projection or collection optic. Each application is derived primarily from the optical architecture of the system and the format of the data being used.

The DLP670S DMD is controlled by two DLPC900 controllers. The DMD itself receives bit planes through a 2xLVDS input data bus and, when input control commands dictate, activates the controls which update the mechanical state of the DMD mirrors. In combination with the DLPC900 Controllers, the chipset enables four unique modes of system level operation:

- Video Mode - 24 bit video signals presented to inputs of the DLPC900 Controllers appear on the DMD. The DMD mirrors are updated in a PWM fashion to construct the 24 bit video data. This mode is similar to standard DLP Display projector use cases.
- Video Pattern Mode - the user can define periods of time for specific patterns to be displayed on the DMD. Those patterns are provided via the input video interface and are constrained to input video timing parameters. This mode is optimal for when the data to be presented is not known in advance of operation, or input data needs to be streamed or updated based on real-time processing conditions.
- Pre-stored Pattern Mode - the user can define the patterns in advance and build the pattern data into an on-board flash memory. Upon power up, the DLPC900 controllers immediately start reading and displaying those patterns. This mode is typically used in applications where the patterns to be used are known in advance and the patterns can all fit in the external flash memory. This mode typically provides the fastest pattern update rates.
- Pattern-on-the-Fly Pattern Mode - the user can download and update pattern data over the DLPC900 input USB data interface. This allows an external processor to modify and update patterns based on external processing decisions. This mode also provides streaming capability similar to the Video Pattern Mode except that the user will need to take into account delays involved with USB transmission of pattern data and control information.

The DLP670S provides solutions for many varied applications including structured light (3-D machine vision), 3-D printing, information projection, and lithography.

The DLP670S contains the most recent breakthrough micromirror technology called the TRP pixel. With a smaller pixel pitch of 5.4  $\mu\text{m}$  and increased tilt angle of 17.5 degrees nominal, TRP chipsets enable higher resolution in a smaller form factor while maintaining high optical efficiency. DLP chipsets are a great fit for any system that requires high resolution and high output projection imaging.

### 8.2 Typical Application

3D machine vision is a typical embedded system applications for the DLP670S DMD. In this application, two DLPC900 devices control the pattern data being imaged from a DLP670S DMD onto the object being measured while an external camera system monitors the projected patterns as they appear on the object. An external microprocessor can then geometrically determine all 3D points of the object using the knowledge of the projected pattern provided to the object, the actual distorted pattern as captured by the camera, and the angle between the projector line-of-sight and the camera line-of-sight. This type of application diagram is shown in [Figure 8-1](#). In this configuration, the DLPC900 controller supports a 24-bit parallel RGB video input from an external source computer or processor. The video input FPGA splits each 2716 x 1600 image frame into a left half and a right half with the left half feeding the primary DLPC900 and the right half feeding the secondary DLPC900. Each half consists of 1358 columns x 1600 rows plus any horizontal and vertical blanking at half the pixel clock rate. This system configuration supports still and motion video as well as sequential pattern modes.

For more information, refer to the DLPC900 digital controller data sheet found on the DLPC900 Product Folder listed under [Section 11.3.1](#).

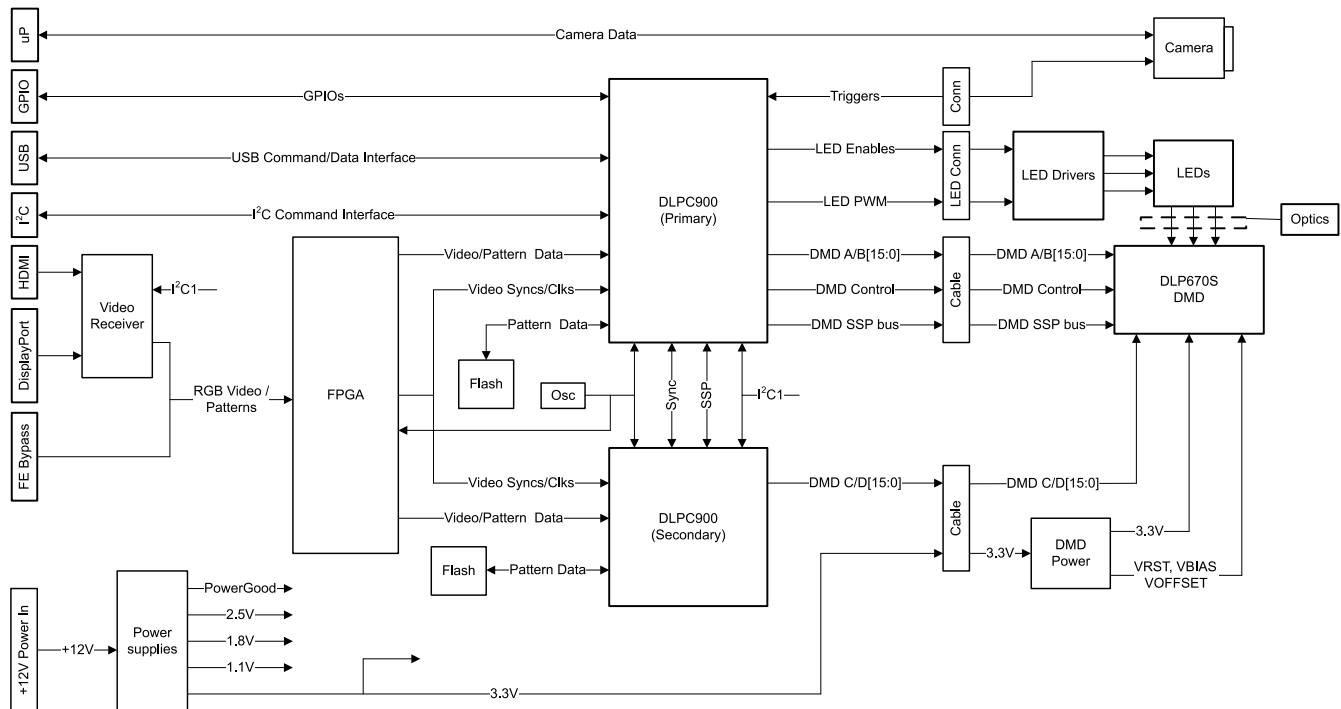

**Figure 8-1. Typical DLP670S Application Diagram**

### 8.2.1 Design Requirements

At the high level, typical DLP670S DMD systems include an illumination source (Lamp, LED, or Laser), an optical light engine containing both illumination and projection optics, mechanics, electronic components, power supplies, cooling systems, and software. The designer must first choose an illumination source and design the optical engine taking into consideration the optical relationship from the illumination source to the DMD, and from the DMD to the location of the projected image. The designer must then understand the electronic components of a DLP670S DMD system, part of which includes one or more PCBs which contain the DMD and Controllers. In the TI DLP670S based evaluation module design, the DLPC900 Controller board provides power, bit plane data, and control information to the DMD mounted on the DLP670S DMD board. The DLPC900 Controller board also interfaces to the user system, accepting image data based on user provided timing (software or hardware triggered) and providing that data in bit plane format to the DMD to be projected on the imaging target.

### 8.2.2 Detailed Design Procedure

A TI evaluation module design exists which shows how to connect the DLPC900 controller to the DMD. In creating a new board specific to a customer application, layout guidelines need to be followed to achieve a functional and reliable projection system. To complete the system, an optical module or light engine is required that contains the DLP670S DMD, associated illumination sources, optical elements, and necessary mechanical components. Care must be taken to understand and implement wise design decisions regarding the engineering aspects of illumination and projection optics, digital and analog electronics, software, and mechanical and thermal design principles.

### 8.3 DMD Die Temperature Sensing

The DMD features a built-in thermal diode that measures the temperature at one corner of the die outside the micromirror array. The DMD thermal diode pins E16 and E17 can be connected to the TMP411 temperature sensor as shown in Figure 8-2, and an external processor can interface with the TMP411 temperature sensor over I<sup>2</sup>C bus to allow monitoring of the DMD temperature. This temperature data can be leveraged to incorporate additional functionality in the overall system design such as adjusting illumination power, cooling fan speeds, TEC current inputs, and so forth, all with the idea of maintaining appropriate temperature control of the DMD.

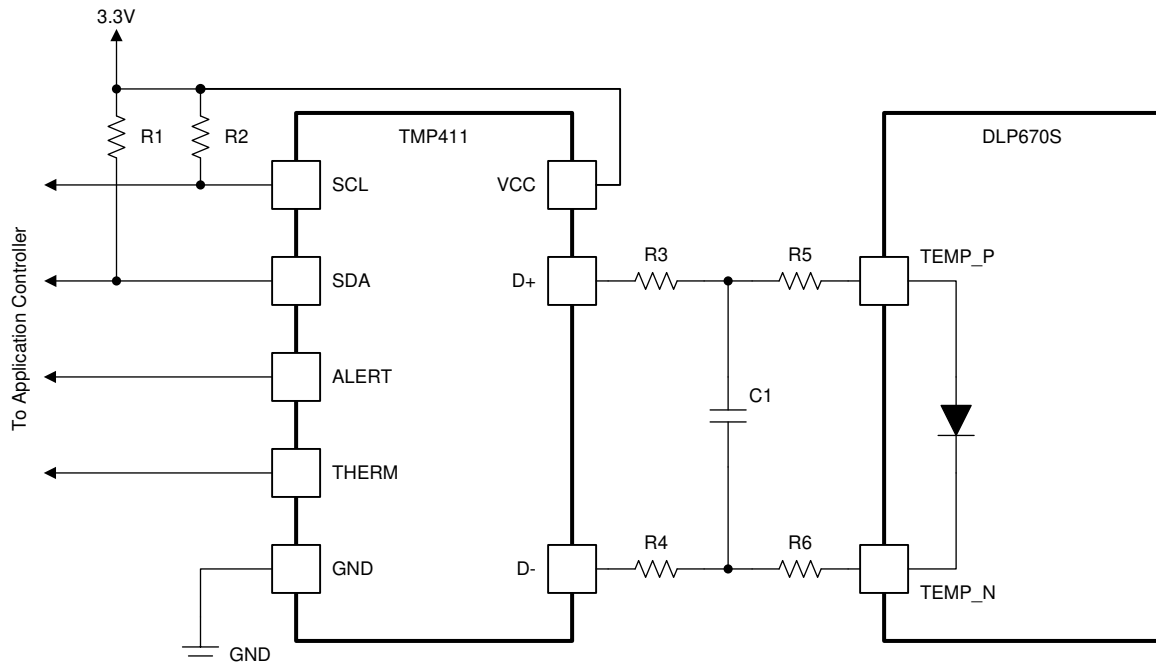

- A. Details omitted for clarity, see the DLPLCR67EVM evaluation module design for connections.
- B. See the [TMP411](#) datasheet for system board layout recommendation.
- C. See the [TMP411](#) datasheet and the DLPLCR67EVM design for suggested component values for R1, R2, R3, R4, and C1.
- D. R5 = 0 Ω. R6 = 0 Ω. 0-Ω resistors need to be located close to the DMD package pins.

**Figure 8-2. TMP411 Sample Schematic**

## 9 Power Supply Recommendations

The following power supplies are all required to operate the DMD:

- VSS
- VCC
- VCCI
- VBIAS
- VOFFSET
- VRESET

DMD power-up and power-down sequencing is very important. Sequencing is controlled by the DLPC900 Controller and through the DMD power supply design.

### CAUTION

For reliable operation of the DMD, the following power supply sequencing requirements must be followed. Failure to adhere to any of the prescribed power-up and power-down requirements may affect device reliability. See [Figure 9-1](#) in [Section 9.2](#).

VBIAS, VCC, VCCI, VOFFSET, and VRESET power supplies must be coordinated during power-up and power-down operations. Failure to meet any of the below requirements results in a significant reduction in the DMD reliability and lifetime. Common ground VSS must also be connected.

### 9.1 DMD Power Supply Power-Up Procedure

- During power-up, VCC and VCCI must always start and settle before VOFFSET plus Delay1 specified in [Table 9-1](#), VBIAS, and VRESET voltages are applied to the DMD.
- During power-up, it is a strict requirement that the voltage delta between VBIAS and VOFFSET must be within the specified limit shown in [Section 6.4](#).
- During power-up, there is no requirement for the relative timing of VRESET with respect to VBIAS.
- Power supply slew rates during power-up are flexible, provided that the transient voltage levels follow the requirements specified in [Section 6.1](#), in [Section 6.4](#), and in [Figure 9-1](#).
- During power-up, LVCMOS input pins must not be driven high until after VCC and VCCI have settled at operating voltages listed in [Section 6.4](#).

### 9.2 DMD Power Supply Power-Down Procedure

- During power-down, VCC and VCCI must be supplied until after VBIAS, VRESET, and VOFFSET are discharged to within the specified limit of ground. See [Table 9-1](#).
- During power-down, it is a strict requirement that the voltage delta between VBIAS and VOFFSET must be within the specified limit shown in [Section 6.4](#).
- During power-down, there is no requirement for the relative timing of VRESET with respect to VBIAS.
- Power supply slew rates during power-down are flexible, provided that the transient voltage levels follow the requirements specified in [Section 6.1](#), in [Section 6.4](#), and in [Figure 9-1](#).
- During power-down, LVCMOS input pins must be less than specified in [Section 6.4](#).

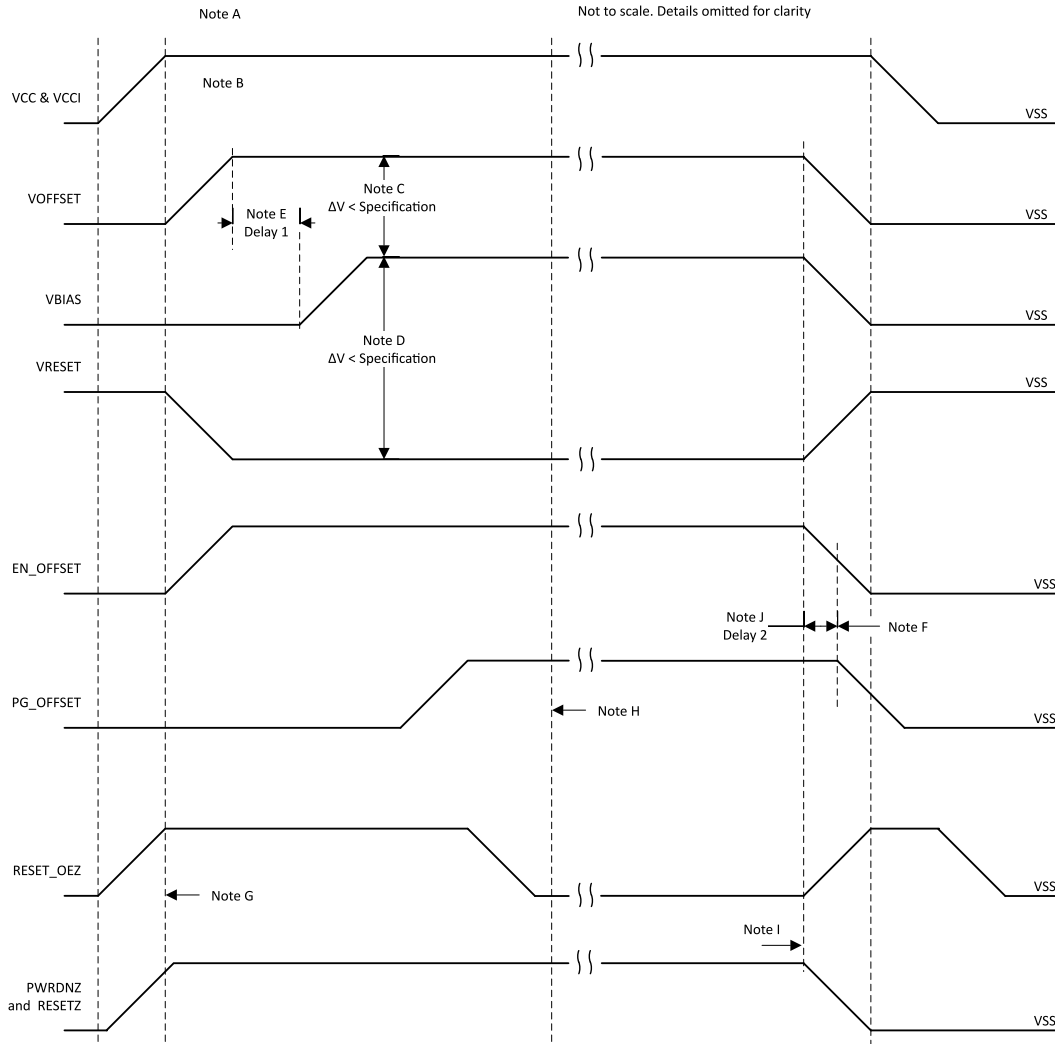

**Figure 9-1. DMD Power Supply Requirements**

- A. See [Section 6.4](#) , and the Pin Functions [Table 5-1](#).
- B. To prevent excess current, the supply voltage delta  $|VCCI - VCC|$  must be less than specified limit in [Section 6.4](#).
- C. To prevent excess current, the supply voltage delta  $|VBIAS - VOFFSET|$  must be less than specified in [Section 6.4](#).
- D. To prevent excess current, the supply voltage delta  $|VBIAS - VRESET|$  must be less than specified limit in [Section 6.4](#).
- E. VBIAS must power up after VOFFSET has powered up, per the Delay1 specification in [Table 9-1](#).
- F. PG\_OFFSET must turn off after EN\_OFFSET has turned off, per the Delay2 specification in [Table 9-1](#).
- G. DLP controller software enables the DMD power supplies to turn on after RESET\_OEZ is at logic high.
- H. DLP controller software initiates the global VBIAS command.
- I. After the DMD micromirror park sequence is complete, the DLP controller software initiates a hardware power-down that activates PWRDNZ and disables VBIAS, VRESET and VOFFSET.
- J. Under power-loss conditions where emergency DMD micromirror park procedures are being enacted by the DLP controller hardware, EN\_OFFSET may turn off after PG\_OFFSET has turned off. The RESET\_OEZ signal goes high prior to PG\_OFFSET turning off to indicate the DMD micromirror has completed the emergency park procedures.

**Table 9-1. DMD Power-Supply Requirements**

Parameter	Description	Min	NOM	Max	Unit
Delay1	Delay from VOFFSET settled at recommended operating voltage to VBIAS power up	1	2		ms
Delay2	PG_OFFSET hold time after EN_OFFSET goes low	100			ns

### 9.3 Restrictions on Hot Plugging and Hot Swapping

The DLP670S uses a state-of-the-art pixel node which enables smaller optics, higher resolution, and overall great performance and reliability as long as certain design-for-assembly methods are used. To maximize DMD reliability, Hot plugging or hot swapping DMDs **voids the DMD warranty conditions and must be avoided at all times.**

#### 9.3.1 No Hot Plugging

Avoid hot plugging, the act of connecting the DMD to power supplies or data inputs that are already energized, to ensure maximum reliability of the DMD. Do not add or remove the DMD from a DMD socket unless all input power supplies of the DMD are at a potential equal to the local ground potential (VSS). This applies to a DMD incoming test station, a partially assembled product, a completed product under test, and a product in the field. This also applies to any cables, flex cables, or PCB connections which provide power to the DMD. Provide power as defined in the power-up scenario detailed in [Section 9.1](#). Perform power down as defined in [Section 9.2](#).

#### 9.3.2 No Hot Swapping

To ensure maximum reliability of the DMD, avoid hot swapping, which is removing and replacing the DMD with DMD power supplies or data inputs that are already energized. Never add or remove the DMD from a DMD socket unless all input power supplies of the DMD are at a potential equal to the local ground potential (VSS). This applies to a DMD incoming test station, a partially assembled product, a completed product under test, and a product in the field. This also applies to any cables, flex cables, or PCB connections that provide power to the DMD. Provide power as defined in the power-up scenario detailed in [Section 9.1](#). Perform power-down as defined in [Section 9.2](#).

#### 9.3.3 Intermittent or Voltage Power Spike Avoidance

When DMD power or data and clock inputs are energized, twisting of the DMD, DMD socket, or DMD board must be avoided when trying to align the DMD within an optical engine. This twisting motion can create power intermittences or voltage spikes exceeding input power and data specifications of the DMD which may ultimately affect the DMD reliability. PCB power, data, clock, and control circuits must be de-energized before making or removing connections, including cables, connectors, probes, and bed-of-nails connections.

PCB and system design considerations must take into account ways to prevent external influence of DMD input power clock, data and control signals. Robust connectors must be used which are resistant to intermittent connections or noise spikes if jostled or vibrated. Connectors must be used which are rated to exceed the number of insertion or removal cycles expected in the application. External electromagnetic emitters must not be placed nearby these sensitive circuits unless adequate EMI shielding is properly used. Sufficient bulk decoupling and component decoupling capacitance as well as appropriate PCB layout techniques must be available for all electrical components within the DMD based "system" such that ground bounce does not occur. See the section on [Section 10.1](#) for more layout information.

## 10 Layout

### 10.1 Layout Guidelines

#### 10.1.1 Critical Signal Guidelines

The DLP670S DMD is one device in a chipset controlled by the DLPC900 controller. The following guidelines are targeted at designing a functioning PCB using this DLP670S DMD chipset. The DLP670S DMD board must be a high-speed multilayer PCB containing high-speed digital logic utilizing dual edge (DDR) LVDS signals at 400-MHz clock rates. [Figure 10-1](#) shows the DLP670S signals and the recommendations needed from and to the DLPC900 controller devices. The DLPC900 device provides the data and control to the DMD. The TPS65145, LP38513 or equivalent devices supply power to the DMD.

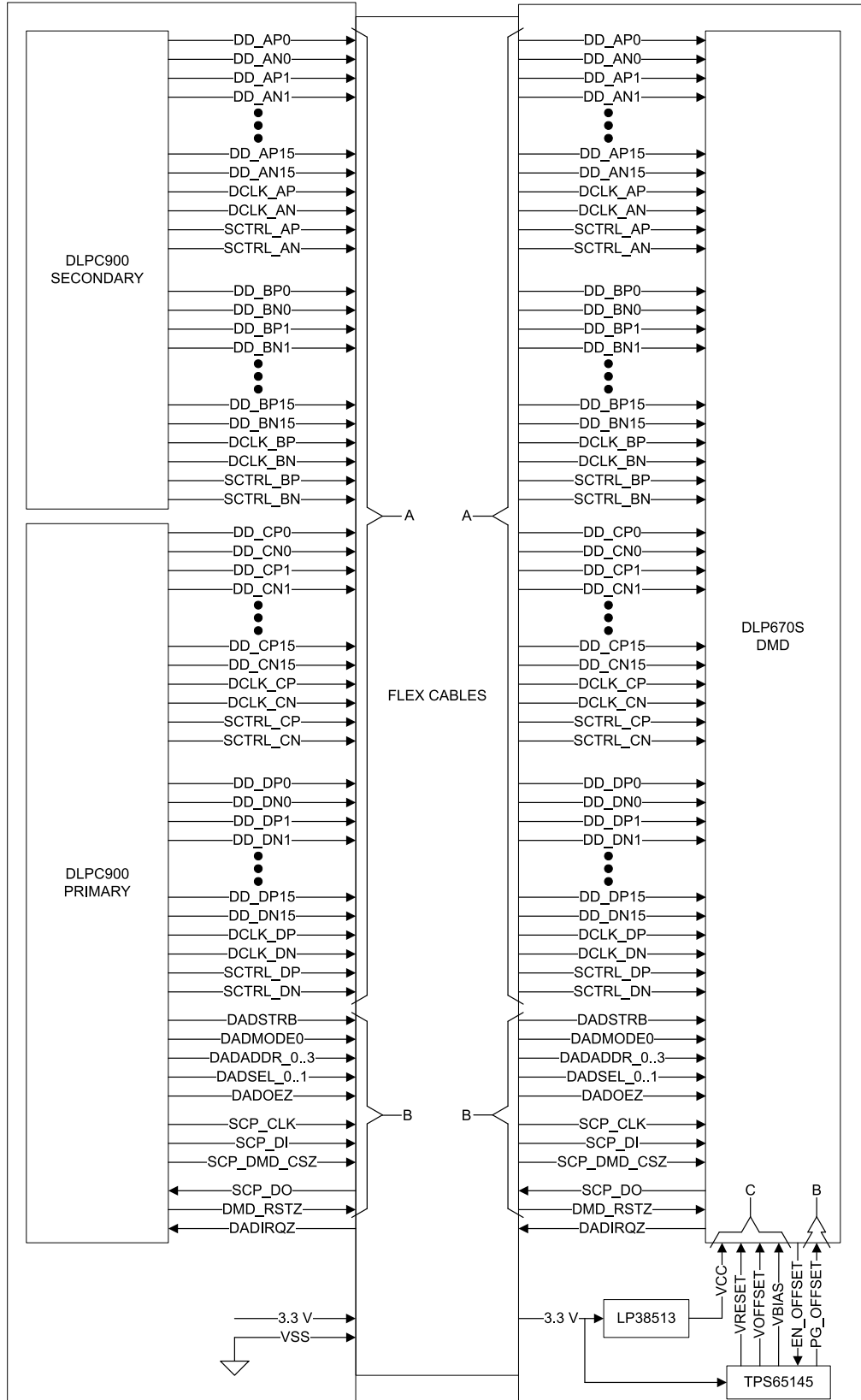

**Figure 10-1. DLP670S DMD System Connections**

**Table 10-1. Layout Restrictions for Figure 10-1**

Note	Signal Type	Guideline
A	Differential	Prevent signal noise
		Route 100 $\pm$ 10- $\Omega$ resistor
		Intra-pair (P-to-N) length tolerance is $\pm$ 12-mils.
		DD and SCTRL must be matched to the DCLK within $\pm$ 150-mils.
		DCLK_C must be matched to DCLK_D within $\pm$ 1.25-ns.
		DCLK_A must be matched to DCLK_B within $\pm$ 1.25-ns.
		Do not switch routing layers except at the beginning and end of trace.
B	Single-ended	Prevent signal noise
		Route single-ended signals 50 $\pm$ 5- $\Omega$
		No length match requirement
C	Power	VRESET, VOFFSET, VBIAS, and VCC at the DMD must be kept within the operating limits specified in the data sheet.
		Provide proper amount of decoupling capacitance for each voltage at the DMD

### 10.1.2 Power Connection Guidelines

The following are recommendations for the power connections to the DMD or DMD PCB:

- Solid planes are **required** for DMD\_P3P3V(3.3V), DMD\_P1P8V and Ground.
- TI strongly recommends partial power planes are used for VOFFSET, VRESET, and VBIAS.
- VOFFSET, VBIAS, VRESET, VCC, and VCCI power rails must be kept within the specified operating range. *This includes effects from ripple and DC error.*
- To accommodate power supply transient current requirements, adequate decoupling capacitance must be placed as near the DMD VOFFSET, VBIAS, VRESET, VCC, and VCCI pins as possible.
- Do not swap DMDs while the DMD is still powered on (this is called hot swapping). All DMD power supply rails and signals must be 0 volts (not driven) before connecting or disconnecting the DMD physical interface.
- Do not allow power to be applied to the DMD when one or more signal pins are not being driven.
- Decoupling capacitor locations for the DMD must be as close as possible to the DMD. The pads of the capacitors must be connected to at least two or three vias to get a very low impedance to ground as shown in [Figure 10-3](#). Furthermore, the capacitor must be in the flow of the power trace as it goes to the input of the DMD.
- It is extremely important to adhere to the [Section 9.1](#) and [Section 9.2](#) and do not allow the DMD power-supply levels to be outside of the recommended operating conditions specified in the DMD data sheet.

These figures show examples of bypass decoupling capacitor layout.

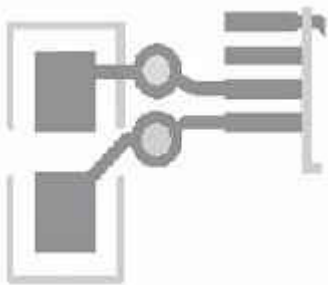
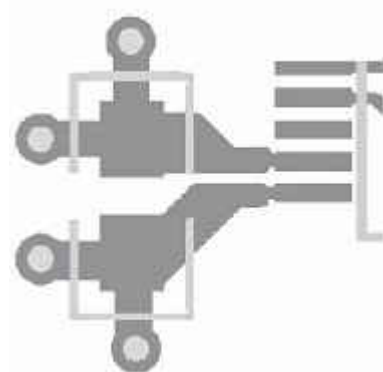
**Figure 10-2. Poor Layout****Figure 10-3. Good Layout**

### 10.1.3 Noise Coupling Avoidance

During operation, it is critical to prevent the coupling of noise or intermittent power connections onto the following signals because irreversible DMD micromirror array damage or lesser effects of image disruption can occur:

- SCTRL\_DN, SCTRL\_DP
- DCLK\_DN, DCLK\_DP
- SCPCLK
- SCPDI
- RESET\_SEL(0), RESET\_SEL(1)
- PG\_OFFSET

In this context, the following conditions are considered noise:

- Shorting to another signal
- Shorting to power
- Shorting to ground
- Intermittent connection (includes hot swapping)
- An electrical open condition
- An electrical floating condition
- Inducing electromagnetic interference that is strong enough to affect the integrity of the signals
- Unstable inputs (conditions outside of the specified operating range) to any of the device power rails
- Voltage fluctuations on the device ground pins

## 10.2 Layout Example

### 10.2.1 Layers

The layer stack-up and copper weight for each layer is shown in [Table 10-2](#). Small subplanes are allowed on signal routing layers to connect components to major sub-planes on top or bottom layers if necessary.

**Table 10-2. Layer Stack-Up**

LAYER NO.	LAYER NAME	COPPER WT. (oz.)	COMMENTS
1	Side A — DMD only	1.5	DMD, escapes, low frequency signals, power subplanes
2	Ground	1	Solid ground plane (net GND)
3	Signal	0.5	50-Ω and 100-Ω differential signals
4	Ground	1	Solid ground plane (net GND)
5	DMD_P3P3V	1	+3.3-V power plane (net DMD_P3P3V)
6	Signal	0.5	50-Ω and 100-Ω differential signals
7	Ground	1	Solid ground plane (net GND)
8	Side B - All other Components	1.5	Discrete components, low frequency signals, power subplanes

### 10.2.2 Impedance Requirements

TI recommends that the board has matched impedance of 50 Ω ±10% for all signals. The exceptions are listed in [Figure 10-1](#) and repeated for convenience in [Table 10-3](#).

**Table 10-3. Special Impedance Requirements**

Signal Type	Signal Name	Impedance (ohms)
A channel LVDS differential pairs	D_AP(0:15), D_AN(0:15)	100 ±10% differential across each pair
	DCLK_AP, DCLK_AN	
	SCTRL_AP, SCTRL_AN	
B channel LVDS differential pairs	D_BP(0:15), D_BN(0:15)	100 ±10% differential across each pair
	DCLK_BP, DCLK_BN	
	SCTRL_BP, SCTRL_BN	

**Table 10-3. Special Impedance Requirements (continued)**

Signal Type	Signal Name	Impedance (ohms)
C channel LVDS differential pairs	D_CP(0:15), D_CN(0:15)	100 ±10% differential across each pair
	DCLK_CP, DCLK_CN	
	SCTRL_CP, SCTRL_CN	
D channel LVDS differential pairs	D_DP(0:15), D_DN(0:15)	100 ±10% differential across each pair
	DCLK_DP, DCLK_DN	
	SCTRL_DP, SCTRL_DN	

### 10.2.3 Trace Width, Spacing

Unless otherwise specified, TI recommends that all signals follow the 0.005 in./0.005 in. design rule. Minimum trace clearance from the ground ring around the PWB has a 0.1-in. minimum. An analysis of impedance and stack-up requirements determine the actual trace widths and clearances.

#### 10.2.3.1 Voltage Signals

Below are additional voltage supply layout examples from the power planes to the individual DMD pins. In general, power supply trace widths must be as wide as possible to reduce impedances.

**Table 10-4. Special Trace Widths, Spacing Requirements**

SIGNAL NAME	MINIMUM TRACE WIDTH TO PINS (MIL)	LAYOUT REQUIREMENT
GND	15	Maximize trace width to connecting pin
DMD_P3P3V	15	Maximize trace width to connecting pin
DMD_P1P8V	15	Maximize trace width to connecting pin
VOFFSET	15	Create mini plane from the power generation to the DMD input
VRESET	15	Create mini plane from the power generation to the DMD input
VBIAS	15	Create mini plane from the power generation to the DMD input
All DMD control input/output connections	10	Use 10 mil etch to connect all signals/voltages to DMD pads

## 11 Device and Documentation Support

### 11.1 Third-Party Products Disclaimer

TI'S PUBLICATION OF INFORMATION REGARDING THIRD-PARTY PRODUCTS OR SERVICES DOES NOT CONSTITUTE AN ENDORSEMENT REGARDING THE SUITABILITY OF SUCH PRODUCTS OR SERVICES OR A WARRANTY, REPRESENTATION OR ENDORSEMENT OF SUCH PRODUCTS OR SERVICES, EITHER ALONE OR IN COMBINATION WITH ANY TI PRODUCT OR SERVICE.

### 11.2 Device Support

#### 11.2.1 Device Nomenclature

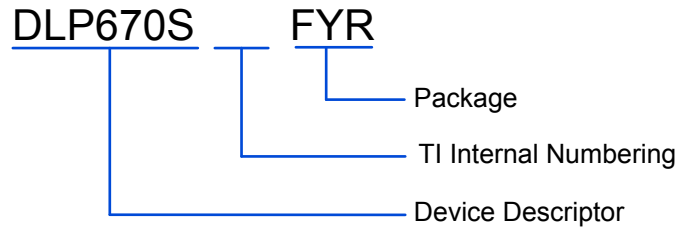
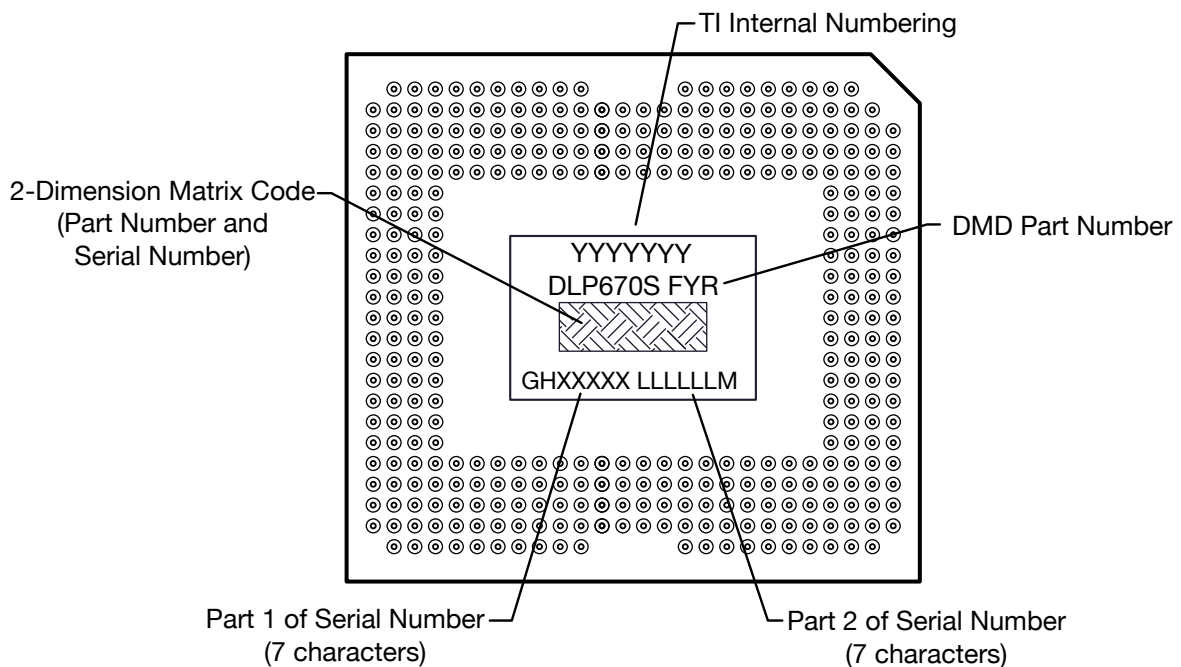

**Figure 11-1. Part Number Description**

#### 11.2.2 Device Markings

The device markings include both human-readable information and a 2-dimensional matrix code. The human-readable information is described in Figure 11-2. The 2-dimensional matrix code is an alpha-numeric character string that contains the DMD part number, Part 1 of Serial Number, and Part 2 of Serial Number. The first character of the DMD Serial Number (part 1) is the manufacturing year. The second character of the DMD Serial Number (part 1) is the manufacturing month.

Example: DLP670SFYR GHXXXXX LLLLLLM



**Figure 11-2. DMD Marking Locations**

## 11.3 Documentation Support

### 11.3.1 Related Documentation

The following documents contain additional information related to the chipset components used with the DLP670S DMD:

- [DLP670S Product Folder](#)
- [DLPC900 Product Folder](#)
- [DLPC900 Programmers Guide](#)
- [DMD Optical Efficiency for Visible Wavelengths](#)
- [DMD 101: Introduction to Digital Micromirror Device \(DMD\) Technology](#)

### 11.4 Receiving Notification of Documentation Updates

To receive notification of documentation updates, navigate to the device product folder on [ti.com](#). Click on *Subscribe to updates* to register and receive a weekly digest of any product information that has changed. For change details, review the revision history included in any revised document.

### 11.5 Support Resources

[TI E2E™ support forums](#) are an engineer's go-to source for fast, verified answers and design help — straight from the experts. Search existing answers or ask your own question to get the quick design help you need.

Linked content is provided "AS IS" by the respective contributors. They do not constitute TI specifications and do not necessarily reflect TI's views; see TI's [Terms of Use](#).

### 11.6 Trademarks

TI E2E™ is a trademark of Texas Instruments.

DLP® is a registered trademark of Texas Instruments.

is a registered trademark of Texas Instruments.

All trademarks are the property of their respective owners.

### 11.7 Electrostatic Discharge Caution



This integrated circuit can be damaged by ESD. Texas Instruments recommends that all integrated circuits be handled with appropriate precautions. Failure to observe proper handling and installation procedures can cause damage.

ESD damage can range from subtle performance degradation to complete device failure. Precision integrated circuits may be more susceptible to damage because very small parametric changes could cause the device not to meet its published specifications.

### 11.8 Glossary

[TI Glossary](#) This glossary lists and explains terms, acronyms, and definitions.

## 12 Mechanical, Packaging, and Orderable Information

The following pages include mechanical, packaging, and orderable information. This information is the most current data available for the designated devices. This data is subject to change without notice and revision of this document. For browser-based versions of this data sheet, refer to the left-hand navigation.

**PACKAGING INFORMATION**

Orderable Device	Status (1)	Package Type	Package Drawing	Pins	Package Qty	Eco Plan (2)	Lead finish/ Ball material (6)	MSL Peak Temp (3)	Op Temp (°C)	Device Marking (4/5)	Samples
DLP670SFYR	ACTIVE	CPGA	FYR	350	21	RoHS & Green	NI-PD-AU	N / A for Pkg Type	0 to 70		Samples

(1) The marketing status values are defined as follows:

**ACTIVE:** Product device recommended for new designs.

**LIFEBUY:** TI has announced that the device will be discontinued, and a lifetime-buy period is in effect.

**NRND:** Not recommended for new designs. Device is in production to support existing customers, but TI does not recommend using this part in a new design.

**PREVIEW:** Device has been announced but is not in production. Samples may or may not be available.

**OBSOLETE:** TI has discontinued the production of the device.

(2) **RoHS:** TI defines "RoHS" to mean semiconductor products that are compliant with the current EU RoHS requirements for all 10 RoHS substances, including the requirement that RoHS substance do not exceed 0.1% by weight in homogeneous materials. Where designed to be soldered at high temperatures, "RoHS" products are suitable for use in specified lead-free processes. TI may reference these types of products as "Pb-Free".

**RoHS Exempt:** TI defines "RoHS Exempt" to mean products that contain lead but are compliant with EU RoHS pursuant to a specific EU RoHS exemption.

**Green:** TI defines "Green" to mean the content of Chlorine (Cl) and Bromine (Br) based flame retardants meet JS709B low halogen requirements of <=1000ppm threshold. Antimony trioxide based flame retardants must also meet the <=1000ppm threshold requirement.

(3) MSL, Peak Temp. - The Moisture Sensitivity Level rating according to the JEDEC industry standard classifications, and peak solder temperature.

(4) There may be additional marking, which relates to the logo, the lot trace code information, or the environmental category on the device.

(5) Multiple Device Markings will be inside parentheses. Only one Device Marking contained in parentheses and separated by a "-" will appear on a device. If a line is indented then it is a continuation of the previous line and the two combined represent the entire Device Marking for that device.

(6) Lead finish/Ball material - Orderable Devices may have multiple material finish options. Finish options are separated by a vertical ruled line. Lead finish/Ball material values may wrap to two lines if the finish value exceeds the maximum column width.

**Important Information and Disclaimer:**The information provided on this page represents TI's knowledge and belief as of the date that it is provided. TI bases its knowledge and belief on information provided by third parties, and makes no representation or warranty as to the accuracy of such information. Efforts are underway to better integrate information from third parties. TI has taken and continues to take reasonable steps to provide representative and accurate information but may not have conducted destructive testing or chemical analysis on incoming materials and chemicals. TI and TI suppliers consider certain information to be proprietary, and thus CAS numbers and other limited information may not be available for release.

In no event shall TI's liability arising out of such information exceed the total purchase price of the TI part(s) at issue in this document sold by TI to Customer on an annual basis.

© COPYRIGHT 2019 TEXAS INSTRUMENTS UN-  
PUBLISHED. ALL RIGHTS RESERVED.

REV	DESCRIPTION	DATE	APPROVED
A	ECO 2181188, INITIAL RELEASE	05/07/2019	F. ARMSTRONG

DWG NO 2516660 SH 1

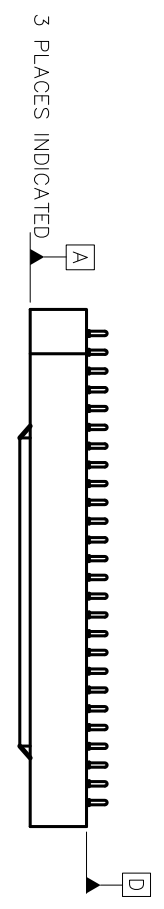

3 PLACES INDICATED

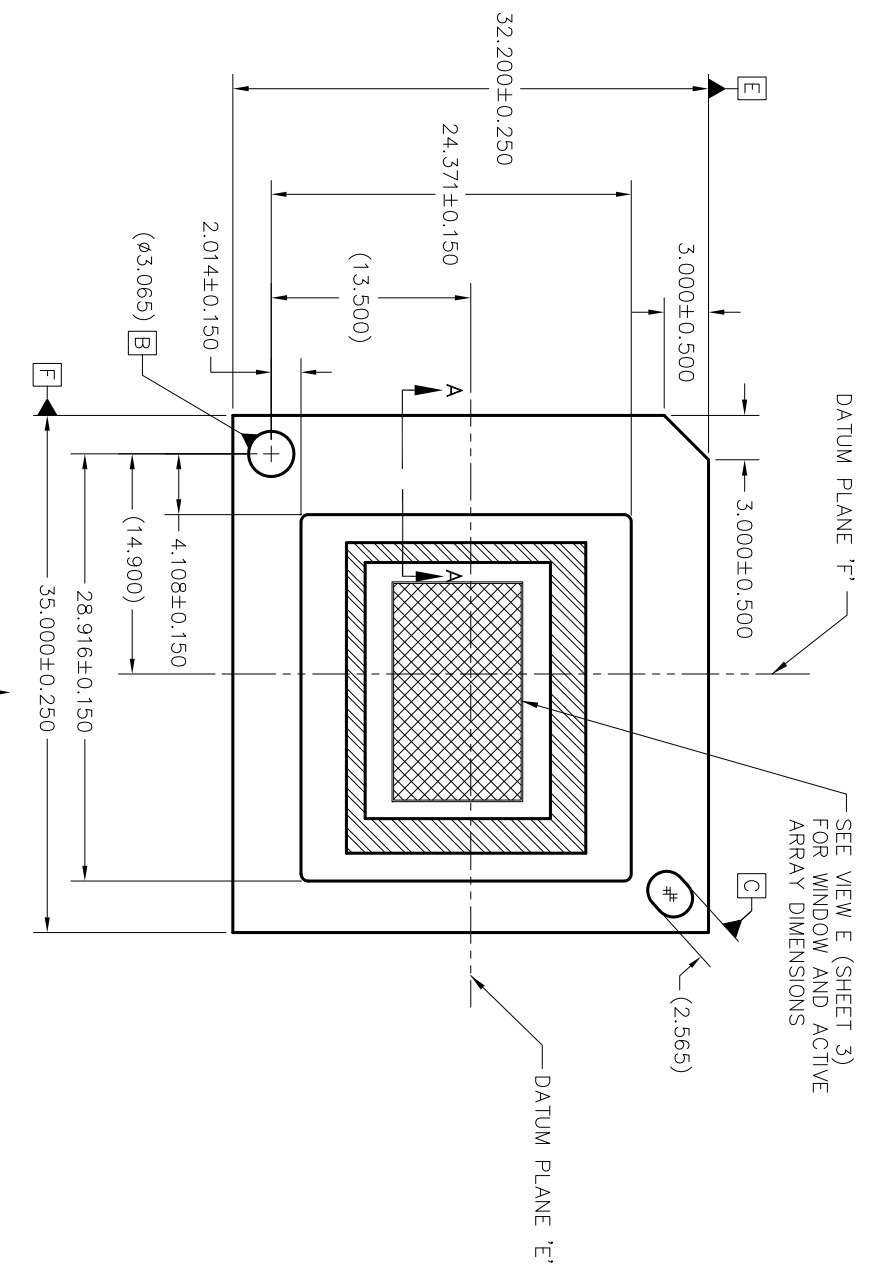

SHT. 4

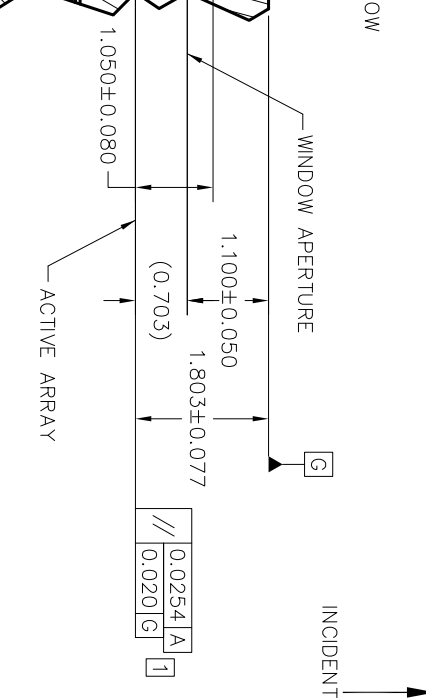

SHT. 4

QTY	ITEM NO	PART OR IDENTIFYING NUMBER	PARTS LIST	DATE	DESCRIPTION	NOTES
-1			ARMSTRONG	05/07/2019		

UNLESS OTHERWISE SPECIFIED  
DIMENSIONS ARE IN MILLIMETERS  
TOLERANCES:  
1 PLACE DECIMALS ±0.25  
2 PLACE DECIMALS ±0.50  
3 PLACE DECIMALS ±0.50  
REMOVE ALL BIRDS AND SHARP EDGES  
INTERPRET DIMENSIONS IN ACCORDANCE WITH ASME Y14.5-1994  
PARENT/CHILD INFO FOR REF ONLY

THIRD ANGLE PRACTICE	QTY	ITEM NO	PART OR IDENTIFYING NUMBER	DATE	DESCRIPTION	NOTES
☐	NONE	0314DA		05/14/2019		
☐	NONE	USED ON		05/14/2019		

SIZE	DRAWING NO	REV
D	2516660	A

TEXAS INSTRUMENTS  
ICD, MECHANICAL, DMD  
.67 HB MTRP 2XLVDS  
SERIES 610 (FYR PACKAGE)

N A-A  
20/1

5 4 3 2 1

A

B

C

D

5

4

3

DWG NO

2516660

SHEET 2

1

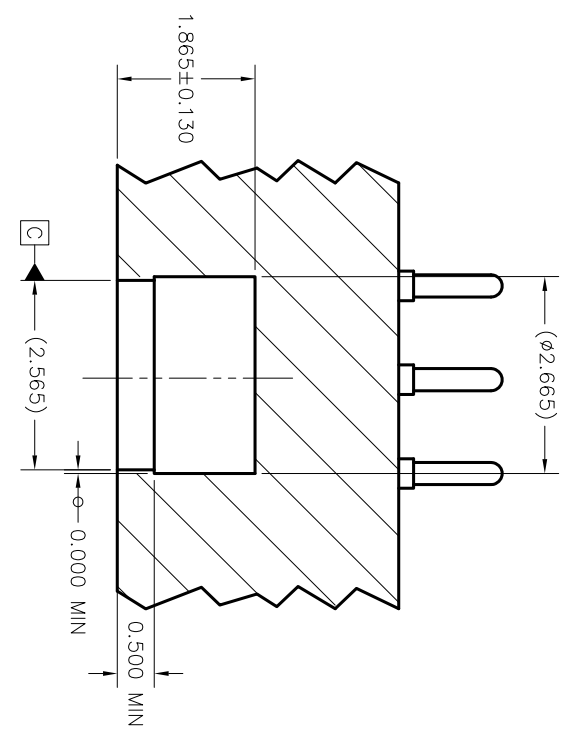
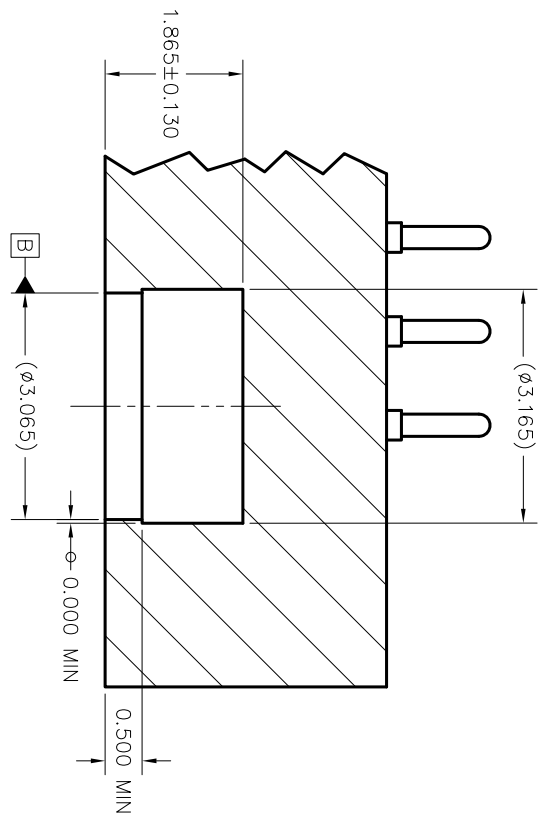
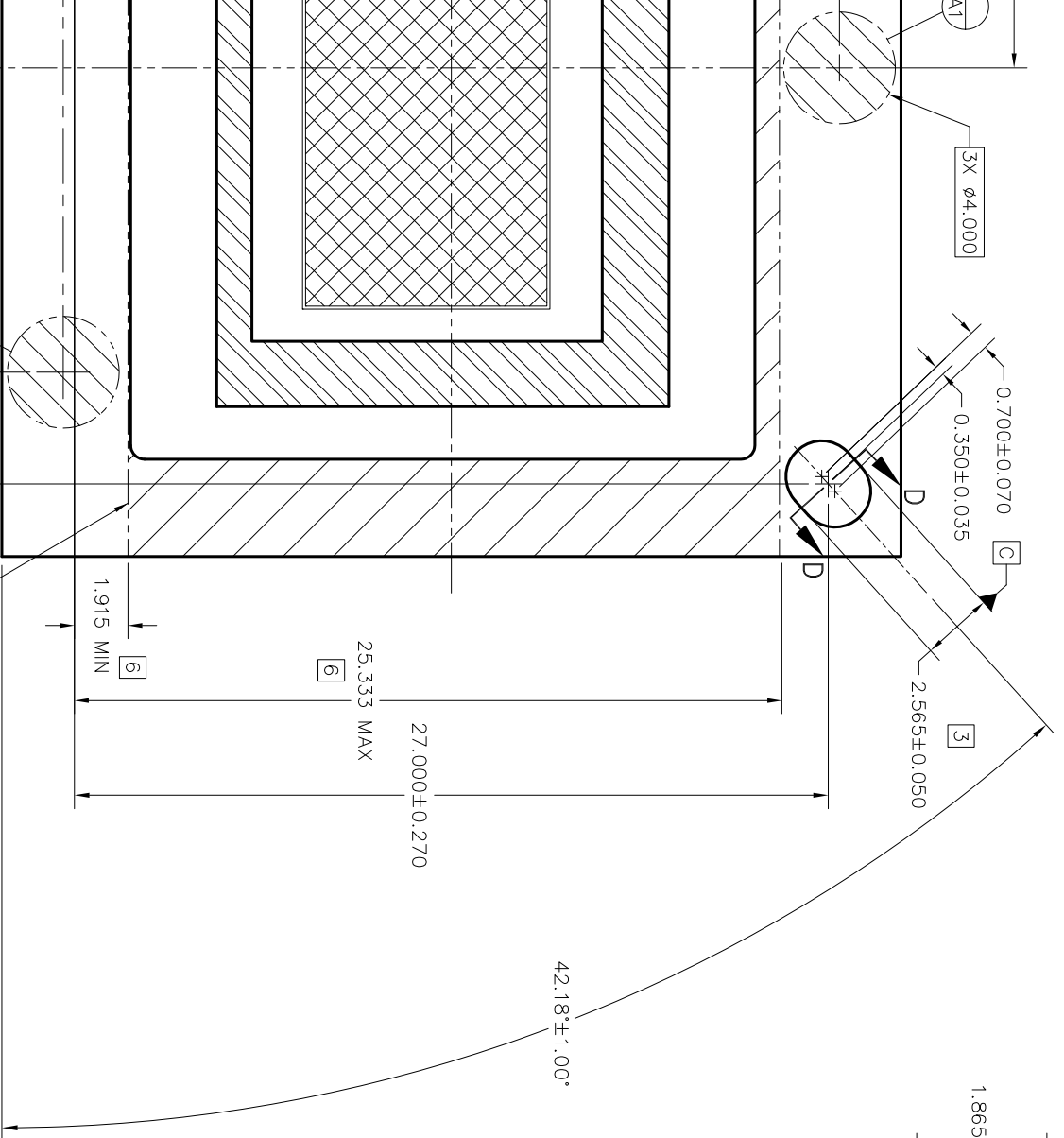
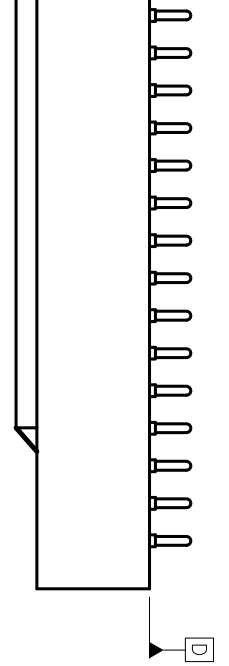

ENCAPSULANT ALLOWED ON CERAMIC AREA

VIEW B  
ENCAPSULANT ALLOWABLE AREA  
SCALE 8/1

TEXAS INSTRUMENTS  
Dallas, Texas

DWG

ISSUE DATE

DATE

SIZE

SCALE 4/1

DRAWING NO

2516660

SHEET 2

5

4

3

2

1

A

B

C

D

5 4 3 1

DWG NO 2516660

SHEET 3

1

2 (14.6664)  
ACTIVE ARRAY

4 2X 0.108

C (2.565)

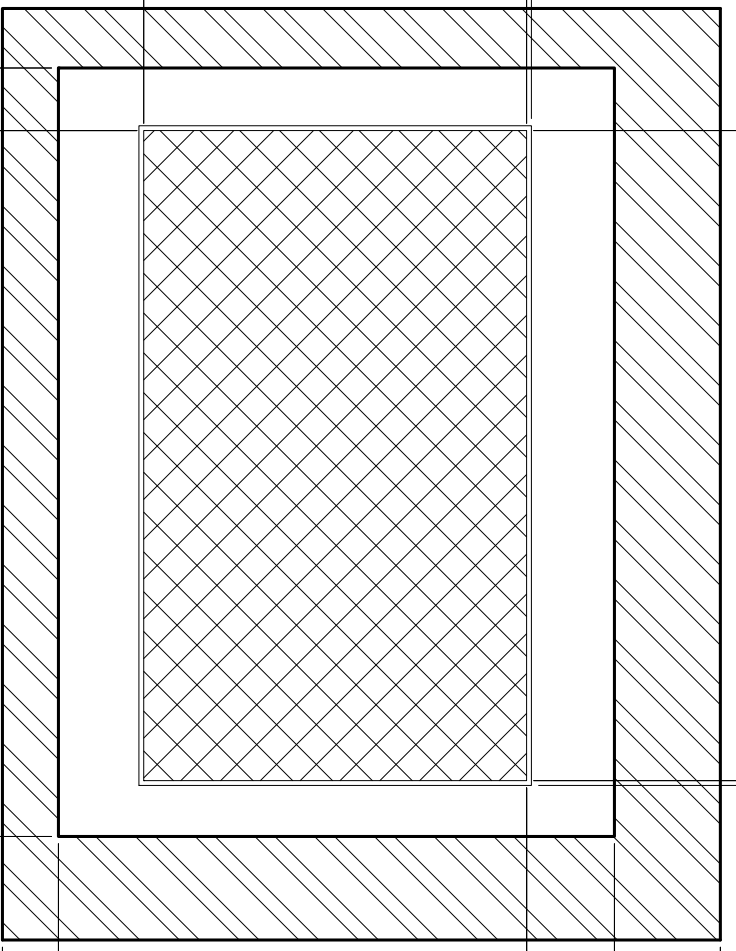

1.980±0.0885

4.37±0.050

(12.543)  
WINDOW  
APERTURE

11.826±0.050

(16.196)  
WINDOW

10.563±0.0885

500  
885

15.926±0.0885

(17.338)  
WINDOW APERTURE

18.264<sup>+0.0500</sup><sub>-0.0885</sub>

(21.02)  
WINDOW

VIEW E (SHEET 1)  
DMD WINDOW AND ACTIVE ARRAY  
SCALE 12/1

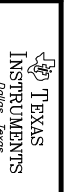

DWG

DATE

SIZE D

SCALE 4/1

DRAWING NO

2516660

SHEET 3

REV A

A

B

C

D

5 4 3 2 1

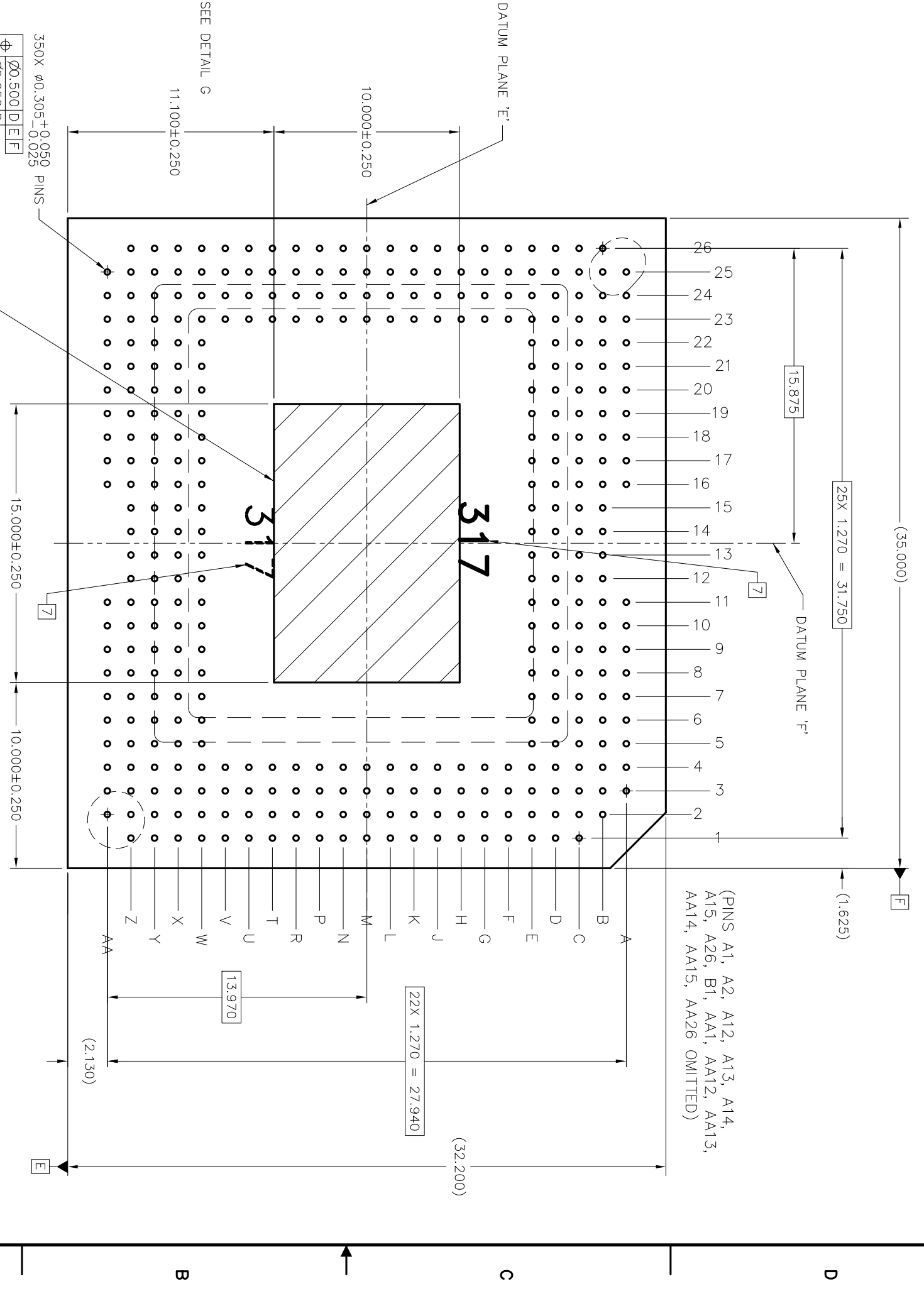

VIEW F--F (SHEET 1)  
PINS AND SYMBOLIZATION PAD  
SCALE 8/1

## IMPORTANT NOTICE AND DISCLAIMER

TI PROVIDES TECHNICAL AND RELIABILITY DATA (INCLUDING DATA SHEETS), DESIGN RESOURCES (INCLUDING REFERENCE DESIGNS), APPLICATION OR OTHER DESIGN ADVICE, WEB TOOLS, SAFETY INFORMATION, AND OTHER RESOURCES "AS IS" AND WITH ALL FAULTS, AND DISCLAIMS ALL WARRANTIES, EXPRESS AND IMPLIED, INCLUDING WITHOUT LIMITATION ANY IMPLIED WARRANTIES OF MERCHANTABILITY, FITNESS FOR A PARTICULAR PURPOSE OR NON-INFRINGEMENT OF THIRD PARTY INTELLECTUAL PROPERTY RIGHTS.

These resources are intended for skilled developers designing with TI products. You are solely responsible for (1) selecting the appropriate TI products for your application, (2) designing, validating and testing your application, and (3) ensuring your application meets applicable standards, and any other safety, security, regulatory or other requirements.

These resources are subject to change without notice. TI grants you permission to use these resources only for development of an application that uses the TI products described in the resource. Other reproduction and display of these resources is prohibited. No license is granted to any other TI intellectual property right or to any third party intellectual property right. TI disclaims responsibility for, and you will fully indemnify TI and its representatives against, any claims, damages, costs, losses, and liabilities arising out of your use of these resources.

TI's products are provided subject to [TI's Terms of Sale](#) or other applicable terms available either on [ti.com](#) or provided in conjunction with such TI products. TI's provision of these resources does not expand or otherwise alter TI's applicable warranties or warranty disclaimers for TI products.

TI objects to and rejects any additional or different terms you may have proposed.

Mailing Address: Texas Instruments, Post Office Box 655303, Dallas, Texas 75265  
Copyright © 2022, Texas Instruments Incorporated

## Looking for pricing, stock, or lifecycle information?

Click below to explore more details on WIN SOURCE:

 [View DLP670SFYR on WIN SOURCE](#)

 [Texas Instruments](#) Information

## Optimize Your Supply Chain with WIN SOURCE Solutions

-  Global Sourcing Solution
-  Obsolete Management
-  Cost Control Management
-  Shortage Management
-  Alternative Solution
-  Excess Inventory Management