



**THE DATASHEET OF  
G2RL-1A-E2-CV-HA DC24**



# G2RL-1A-E2-CV-HA

PCB Power Relay

## Compact single pole Relay for High Current Load Switching & High Ambient Temperature

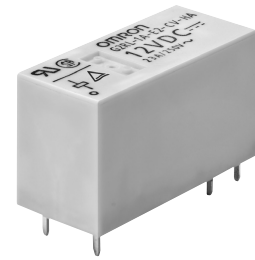

- High current 23 A switching surpassing standard G2RL models.
- Meets ambient operating temperature requirements of 105°C
- Low profile; 16.7 mm max. in height.
- Reinforced insulation between coil and contact with 10 kV Impulse voltage.
- Conforms to EN60335-1 of Safety of Household appliances.
- Clearance and creepage distances: 8 mm / 8 mm min.
- Coil insulation system: Class F (UL1446)

RoHS Compliant

### Model Number Legend

G2RL-□□□-□□□□  
1 2 3 4 5 6

- |   |  |
|---|--|
| <b>1. Number of pole</b><br>1: 1 Pole               | <b>4. Classification</b><br>E2: High-capacity at 23 A                    |
| <b>2. Contact Form</b><br>A: SPST-NO (1a)           | <b>5. Special Requirement</b><br>CV: Ambient operating temperature 105°C |
| <b>3. Enclosure Rating</b><br>None: Flux protection | <b>6. Market Code</b><br>HA: Home Appliance according to IEC/EN60335-1   |

### Application Examples

- Home appliances
- Cooking top, Microwave Oven
- Industrial use
- HVAC

### Ordering Information

Classification	Contact form	Enclosure rating	Model	Rated coil voltage	Minimum packing unit
High-capacity & High-temperature	SPST-NO (1a)	Flux protection	G2RL-1A-E2-CV-HA	5 VDC 12 VDC 24 VDC	100 pcs. / tray

**Note: 1.** When ordering, add the rated coil voltage to the model number.

Example: G2RL-1A-E2-CV-HA DC5

Rated coil voltage

However, the notation of the coil voltage on the product case will be marked as □□VDC.

**Note: 2.** Place your order in tray (100 pcs./tray) units.

### Ratings

#### Coil Ratings

Rated voltage	Item Rated current (mA)	Coil resistance (Ω)	Must-operate voltage (V)	Must-release voltage (V)	Max. voltage (V)	Power consumption (mW)
5 VDC	80.0	62.5	75% max.	10% min.	130% (at 23°C)	Approx. 400
12 VDC	33.3	360				
24 VDC	16.7	1,440				

**Note: 1.** The rated current and coil resistance are measured at a coil temperature of 23°C with a tolerance of ±10%.

**Note: 2.** The operating characteristics are measured at a coil temperature of 23°C.

**Note: 3.** The "Max. voltage" is the maximum voltage that can be applied to the relay coil.

#### Contact

Classification	High-capacity & High-temperature type (resistive load)
Item	Model
	G2RL-1A-E2-CV-HA
Contact type	Single
Contact material	Ag-Alloy (Cd free)
Rated load	23 A at 250 VAC
Rated carry current	23 A
Max. switching voltage	250 VAC
Max. switching current	23 A

## Characteristics

Item	Classification	High-capacity & High-temperature type
	Model	G2RL-1A-E2-CV-HA
Contact resistance *1		100 mΩ max.
Operate time		15 ms max.
Release time		5 ms max.
Insulation resistance *2		1,000 MΩ min.
Dielectric strength	Between coil and contacts	5,000 VAC, 50/60 Hz for 1 min
	Between contacts of the same polarity	1,000 VAC, 50/60 Hz for 1 min
Impulse withstand voltage		10 kV (1.2 × 50 μs)
Vibration resistance	Destruction	10 to 55 to 10 Hz, 0.75 mm single amplitude (1.5 mm double amplitude)
	Malfunction	10 to 55 to 10 Hz, 0.75 mm single amplitude (1.5 mm double amplitude)
Shock resistance	Destruction	1,000 m/s <sup>2</sup>
	Malfunction	Energized: 100 m/s <sup>2</sup> , De-energized: 100 m/s <sup>2</sup>
Durability	Mechanical	20,000,000 operations (18,000 operation per hour)
	Electrical *3 (resistive load)	100,000 operations at 250 VAC, 23 A, at 105°C (1s ON / 9s OFF)
Ambient operating temperature		-40°C to 105°C (with no icing or condensation)
Ambient operating humidity		5% to 85% (with no icing or condensation)
Weight		Approx. 12 g

Note: Values in the above table are the initial values at 23°C.

\*1. Measurement conditions: 5 VDC, 1 A, voltage drop method

\*2. Measurement conditions: Measured at the same points as the dielectric strength using a 500 VDC ohmmeter.

\*3. 360 operations per hour.

## Engineering Data

### ● Maximum Switching Capacity

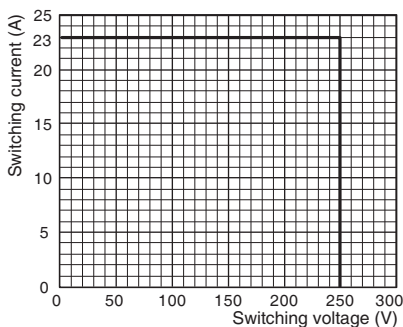

### ● Ambient Temperature vs. Maximum Coil Voltage

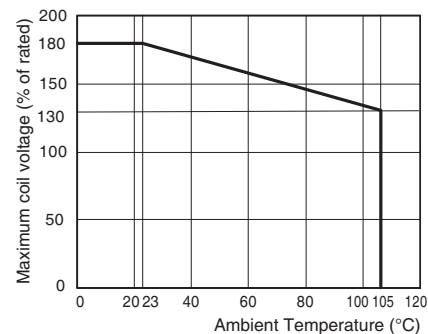

Note: The maximum coil voltage refers to the maximum value in a varying range of operating power voltage, not a continuous voltage.

### ● Shock Malfunction

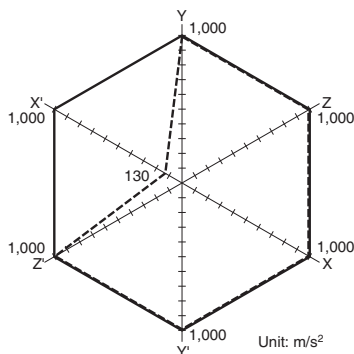

Test conditions: Shock is applied in  $\pm X$ ,  $\pm Y$ , and  $\pm Z$  directions three times each with without energizing the Relays to check the number of malfunctions.

Requirement: None malfunction  
100 m/s<sup>2</sup>

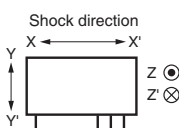

### ● Ambient Temperature vs. Must Operate and Must Release Voltage

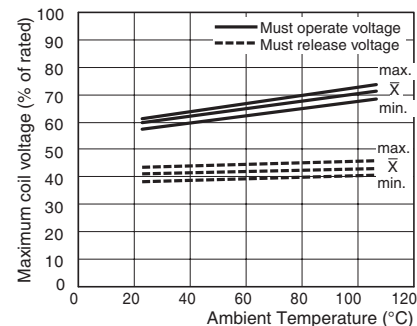

## Dimensions

(Unit: mm)

### G2RL-1A-E2-CV-HA

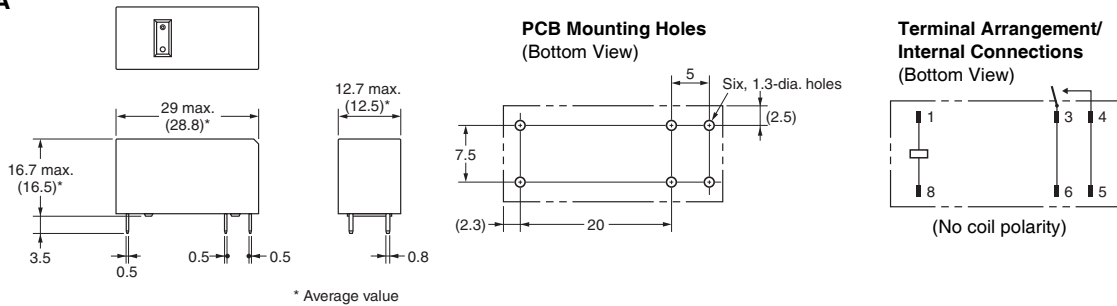

## Approved Standards

UL Recognized: (File No. E41643)

CSA Certified: (File No. LR31928)

Model	Contact form	Coil ratings	Contact ratings	Number of test operations
G2RL-1A-E2-CV-HA	SPST-NO (1a)	5 to 24 V	23 A, 250 VAC (Resistive) 105°C	100,000

EN/IEC, TÜV: (Certified/No.\*\*\*\*\*)

Model	Contact form	Coil ratings	Contact ratings	Number of test operations
G2RL-1A-E2-CV-HA	SPST-NO (1a)	5 to 24 V	23 A, 250 VAC (cosφ=1) 105°C	100,000

Creepage distance	8 mm min.
Clearance distance	8 mm min.
Insulation material group	IIIa
Type of insulation coil-contact open contact circuit	Reinforced Micro disconnection
Rated insulation voltage	250 V
Pollution degree	3
Rated voltage system	250 V
Over voltage category	III
Category of protection according to IEC61810-1	RTII (flux protection)
Glow wire according to IEC 60335-1	GWT 750°C min. (IEC 60695-2-11/GWFI 850°C min (IEC 60695-2-12)
Tracking Index of relay base	PTI 250 V min. (housing parts)
Flammability class according to UL94	V-0
Coil Insulation system	F Class (UL 1446)

## Precautions

●Please refer to *PCB Relays Common Precautions* for correct use.

### Electrical Appliance and Material Safety Law (Japan)

The G2RL-1A-E2 series is not compliant with the Electrical Appliance and Material Safety Law of Japan. Please pay careful attention to select a suitable relay for the application.

- Application examples provided in this document are for reference only. In actual applications, confirm equipment functions and safety before using the product.
- Consult your OMRON representative before using the product under conditions which are not described in the manual or applying the product to nuclear control systems, railroad systems, aviation systems, vehicles, combustion systems, medical equipment, amusement machines, safety equipment, and other systems or equipment that may have a serious influence on lives and property if used improperly. Make sure that the ratings and performance characteristics of the product provide a margin of safety for the system or equipment, and be sure to provide the system or equipment with double safety mechanisms.

## OMRON Corporation

Electronic and Mechanical Components Company

### Regional Contact

#### Americas

<https://www.components.omron.com/>

#### Asia-Pacific

<https://ecb.omron.com.sg/>

#### Korea

<https://www.omron-ecb.co.kr/>

#### Europe

<http://components.omron.eu/>

#### China

<https://www.ecb.omron.com.cn/>

#### Japan

<https://www.omron.co.jp/ecb/>

## Looking for pricing, stock, or lifecycle information?

Click below to explore more details on WIN SOURCE:

- ⊖ [View G2RL-1A-E2-CV-HA DC24 on WIN SOURCE](#)
- ⊖ [Omron Information](#)

## Optimize Your Supply Chain with WIN SOURCE Solutions

- ✓ Global Sourcing Solution
- ✓ Obsolete Management
- ✓ Cost Control Management
- ✓ Shortage Management
- ✓ Alternative Solution
- ✓ Excess Inventory Management