



**THE DATASHEET OF
10155447-113LF**



MicroSpaceXS™ 1.27mm Unsealed Crimp-to-Wire Connector Platform

COMPACT, ROBUST AND VERSATILE CONNECTOR SYSTEM

MicroSpaceXS™ Crimp-to-Wire connector platform's unique design meets LV214 up to Severity-3 and USCAR-T2V2 specifications. These 1.27mm pitch connectors come with a current rating up to 4A per contact making them ideal for higher power applications. MicroSpaceXS™ connectors are available in staggered pin configuration in vertical and horizontal orientations and in Wire-to-Board and Wire-to-Wire configurations. These connectors are offered in tin or gold plating.

- LV214 Up to Severity-3 USCAR-T2V2 compatible
- Terminal Positioning Assurance (TPA)
- Primary and secondary contact retention
- Connector Positioning Assurance (CPA)



TARGET MARKETS



FEATURES

- Mechanical Connector Position Assurance (CPA)
- Terminal Position Assurance (TPA)
- Poka-Yoke polarization and color coding
- Current rating up to 4A per contact
- 4N normal force for vibration > 75N connector locking strength

BENEFITS

- Ensures proper mating of header and receptacle and avoids unintentional trigger of the latch
- Ensures proper terminal insertion position and retention
- Prevents visual mismatch
- Meets higher power performance requirements
- High vibration and locking resistance

TECHNICAL INFORMATION

MATERIAL

- Contact: High current alloy with optional Tin and Gold/GXT® plating
- Housing: High temperature thermoplastic, UL94V-0
- Platings:
 - Tin (Sn): 3μ
 - Gold (Au): 0.76μ

ELECTRICAL PERFORMANCE

- Current Rating: 4A
- Voltage Rating: 48V
- Low Level Contact Resistance: <30mΩ
- Insulation Resistance: >100mΩ
- Dielectric Withstanding Voltage: 500VAC
- Temperature Rise: 30°C max.

MECHANICAL PERFORMANCE

- Terminal Insertion Force/Terminal: <3N
- Low Insertion Force Terminal:(<2N) available upon request
- Terminal Retention into Housing: >40N
- Durability:
 - 20 mating cycles for Sn
 - 100 mating cycles for Au/GXT®

ENVIRONMENTAL

- Operating Temperature Range:
 - -40°C to +105°C for Sn
 - -40°C to +150°C for Au
- UL94V-0

APPROVALS AND CERTIFICATIONS

- LV214 Severity-2 for Tin plating
- LV214 Severity-3 for Gold plating
- USCAR-T2V2
- VW75174 – Slow Motion Bending Test
- VW60330 – Crimp specification

SPECIFICATIONS

- Product Specification: GS-12-1634
- Packaging Specification: GS-14-2777

PACKAGING

- PCB Header: Tube
- Receptacle Housing: Bag
- Terminal: Reel

TARGET MARKETS/APPLICATIONS



Lighting
Camera / Sensor
Infotainment
HVAC
Battery Management



Automotive Lighting

PART NUMBERS

Description	Part Numbers
MicroSpaceXS™ Header Horizontal Top Latch	10155500
MicroSpaceXS™ Header Horizontal Side Latch W/O CPA	10155510
MicroSpaceXS™ Header Horizontal Side Latch W/ CPA	10155550
MicroSpaceXS™ Header Vertical Top Latch	10155502
MicroSpaceXS™ Header Vertical Side Latch W/O CPA	10155512
MicroSpaceXS™ Header Vertical Side Latch W/ CPA	10155552
MicroSpaceXS™ Receptacle Top Latch	10155504
MicroSpaceXS™ Receptacle Side Latch W/O CPA	10155514
MicroSpaceXS™ Receptacle Side Latch W/ CPA	10155516
MicroSpaceXS™ Terminals	10155447

PART NUMBER SELECTOR – HEADER

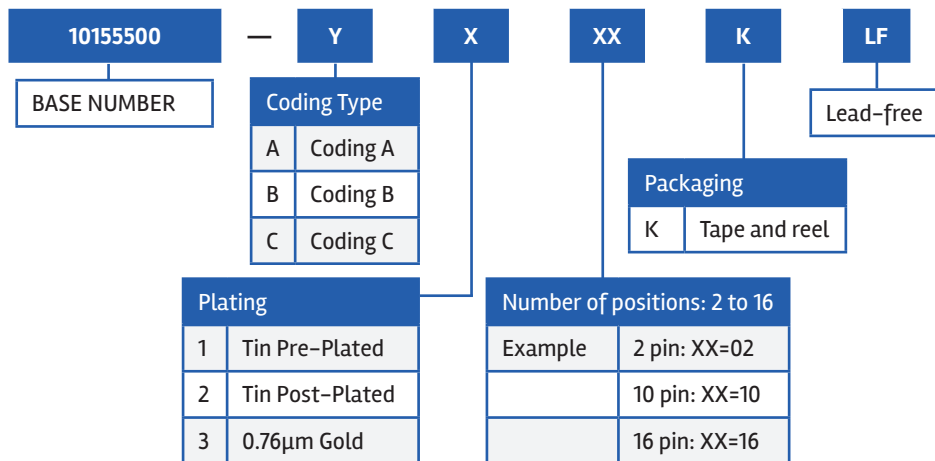

PART NUMBER SELECTOR – RECEPTACLE

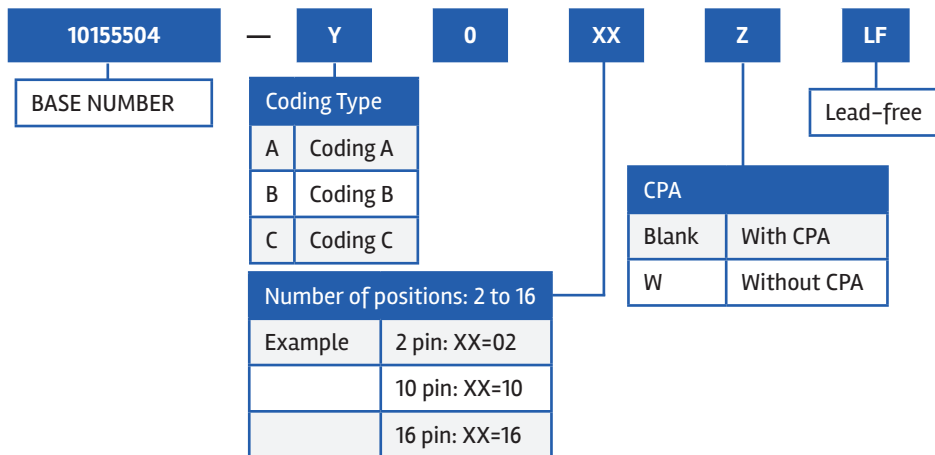

PART NUMBER SELECTOR – TERMINALS

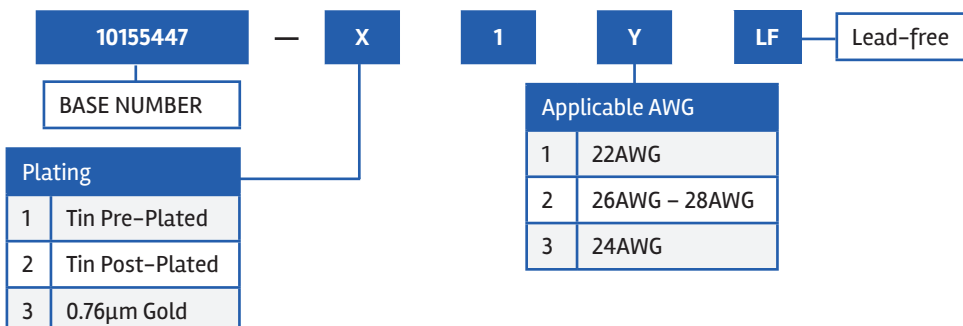

TECHNICAL INFORMATION

MATERIAL

- Contact: High current alloy with optional Tin and Gold/GXT® plating
- Housing: High temperature thermoplastic, UL94V-0
- Platings:
 - Tin (Sn): 3μ
 - Gold (Au): 0.76μ

ELECTRICAL PERFORMANCE

- Current Rating: 4A
- Voltage Rating: 48V
- Low Level Contact Resistance: <30mΩ
- Insulation Resistance: >100mΩ
- Dielectric Withstanding Voltage: 500VAC
- Temperature Rise: 30°C max.

MECHANICAL PERFORMANCE

- Terminal Insertion Force/Terminal: <3N
- Low Insertion Force Terminal:(<2N) available upon request
- Terminal Retention into Housing: >40N
- Durability:
 - 20 mating cycles for Sn
 - 100 mating cycles for Au/GXT®

ENVIRONMENTAL

- Operating Temperature Range:
 - -40°C to +105°C for Sn
 - -40°C to +150°C for Au
- UL94V-0

APPROVALS AND CERTIFICATIONS

- LV214 Severity-2 for Tin plating
- LV214 Severity-3 for Gold plating
- USCAR-T2V2
- VW75174 – Slow Motion Bending Test
- VW60330 – Crimp specification

SPECIFICATIONS

- Product Specification: GS-12-1634
- Packaging Specification: GS-14-2777

PACKAGING

- WTW Header: Bag
- Receptacle Housing: Bag
- Terminal: Reel

TARGET MARKETS/APPLICATIONS



Lighting
Camera / Sensor
Infotainment
HVAC
Battery Management



Automotive Lighting

PART NUMBERS

Description	Part Numbers
MicroSpaceXS™ Receptacle Unsealed Top latch	10155504
MicroSpaceXS™ WTW Unsealed header	10155520
MicroSpaceXS™ Terminals Female	10155447
MicroSpaceXS™ Terminals Male	10155449

PART NUMBER SELECTOR – HEADER

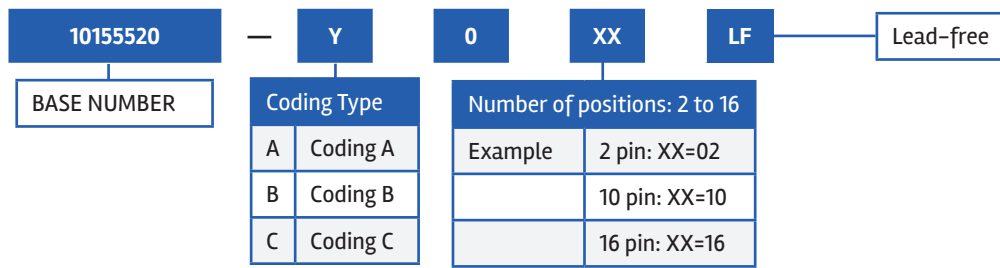

PART NUMBER SELECTOR – RECEPTACLE

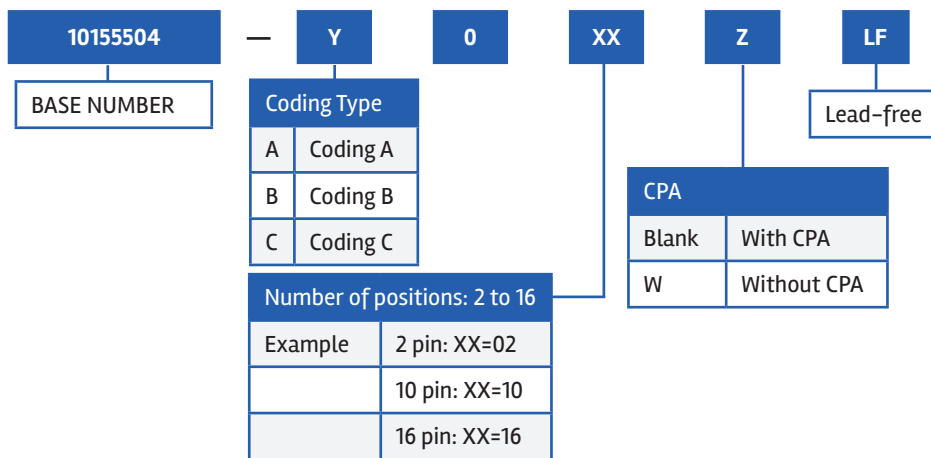

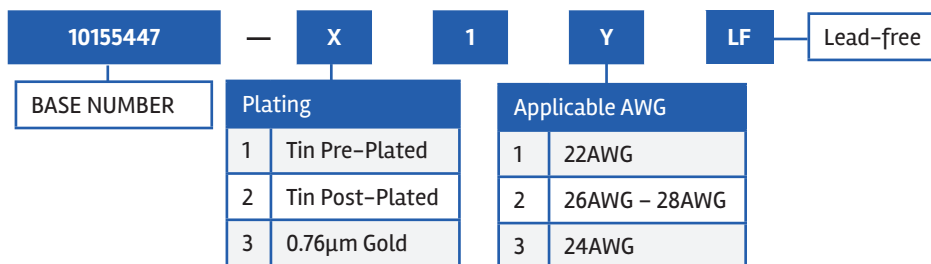

PART NUMBER SELECTOR – TERMINALS



Looking for pricing, stock, or lifecycle information?

Click below to explore more details on WIN SOURCE:

-  [View 10155447-113LF on WIN SOURCE](#)
-  [Amphenol FCI Information](#)

Optimize Your Supply Chain with WIN SOURCE Solutions

-  Global Sourcing Solution
-  Obsolete Management
-  Cost Control Management
-  Shortage Management
-  Alternative Solution
-  Excess Inventory Management