



**THE DATASHEET OF
QPQ3500TR7**



General Description

The QPQ3500 is an exceptionally high-performance BAW Filter for sub-Band 42. This filter is housed in a compact 2.0 x 1.6 mm package for base station applications.

Low insertion loss coupled with high attenuation makes this filter an ideal choice for TDD Macro Cells and Small Cells.

The QPQ3500 is part of Qorvo's extensive portfolio of RF BAW and SAW filters.

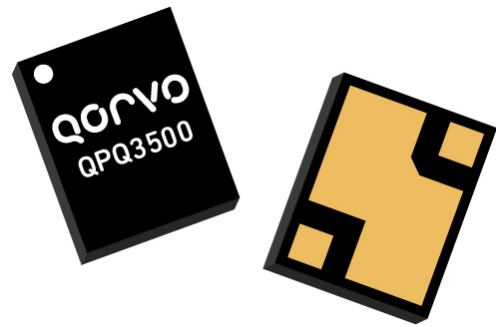

3 Pin 2.0 x 1.6 mm leadless SMT Package

Functional Block Diagram

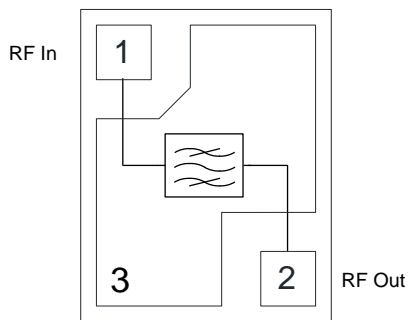

Top View

Pin Configuration

Pin No.	Label
1	RF In
2	RF Out
3	GND Back Side Paddle

Product Features

- 200 MHz Bandwidth – Band 42
- High Attenuation
- Low Loss
- No External Matching Required
- Excellent Wi-Fi Rejection
- Single Input, Single Output Operation
- Small Size: 2.00 x 1.60 x 0.89 mm
- Surface Mount Device
- RoHS Compliant, Pb-Free

Performance is typical across frequency. Please reference electrical specification table and data plots for more details.

Applications

- Band 42
- Base Station Infrastructure
- Small Cells
- Repeaters
- Routers
- LTE Dongles
- General Purpose Wireless

Ordering Information

Part	Description
QPQ3500TR7	2500 pieces on a 7" Reel.
QPQ3500EVB	Evaluation Board – QPQ3500

Absolute Maximum Ratings

Parameter	Rating
Storage Temperature	-40 to 125 °C
Operation Temperature	-40 to +95 °C
RF Input Power - Test conditions: PW = 500ms; DC = 50% @ +25 °C	37 dBm

Exceeding any one or a combination of the Absolute Maximum Rating conditions may cause permanent damage to the device. Extended application of Absolute Maximum Rating conditions to the device may reduce device reliability.

Minimum Lifetime Ratings

Conditions	Rating
29 dBm at Pin 1, FD-LTE, 5 MHz, 16 QAM, PAR 8 dB, +95°C	>10 years

Electrical Specifications ⁽¹⁾ ⁽²⁾ ⁽³⁾

Test Conditions unless otherwise noted= -40°C to +95°C

Parameter	Conditions	Min	Typ. ⁽⁴⁾	Max	Unit
Frequency Range		3400		3600	MHz
Integrated Insertion Loss ⁽⁵⁾	3400 – 3600 MHz	-	2.25	3.2	dB
Amplitude Variation ⁽⁶⁾	3400 – 3600 MHz	-	0.16	1.0	dB
Error Vector Magnitude ⁽⁷⁾	3400 – 3600 MHz	-	0.58	3	%
Group Delay Variation ⁽⁷⁾	3400 – 3600 MHz	-	2.26	10	ns
Input Return Loss	3400 – 3600 MHz	9.5	15.6	-	dB
Input VSWR	3400 – 3600 MHz	-	1.4:1	2.0:1	-
Output Return Loss	3400 – 3600 MHz	9.5	11.5		dB
Output VSWR	3400 – 3600 MHz	-	1.7:1	2.0:1	-
Integrated Rejection ⁽⁸⁾	3200 – 3305 MHz	30	43	-	dB
Integrated Rejection ⁽⁸⁾	3680 – 4180 MHz	30	37	-	dB
Attenuation ⁽⁹⁾	10 – 960 MHz	30	44	-	dB
	960 – 1440 MHz	25	40	-	dB
	1440 – 1490 MHz	21	37	-	dB
	1490 – 1880 MHz	30	40	-	dB
	1880 – 2170 MHz	30	40	-	dB
	2170 – 2473 MHz	30	40	-	dB
	2473 – 2483 MHz	30	42	-	dB
	3200 – 3305 MHz	30	43	-	dB
	3680 – 4180 MHz	30	38	-	dB
	4180 – 4480 MHz	25	32	-	dB
	4480 – 5365 MHz	26	39	-	dB
	5365 – 5925 MHz	30	44	-	dB
	6800 – 7200 MHz	24	38	-	dB

Notes:

1. All specifications are based on the Qorvo schematic shown on page 3.
2. In production, devices will be tested at room temperature to a guard banded specification to ensure compliance over temperature.
3. Electrical margin has been built into the design to account for variations due to temperature drift and manufacturing tolerances.
4. Typical values are based on average measurements at room temperature.
5. Insertion Loss is Integrated over any 5MHz bandwidth within defined frequency band.
6. Maximum Insertion Loss Variation between specified frequencies over any 5 MHz bandwidth
7. Across the band between specified frequencies in 5 MHz sliding window
8. Integrated Rejection over 5 MHz BW within specified frequencies
9. Attenuation is referenced to ZERO dB

QPQ3500EVB Evaluation Board

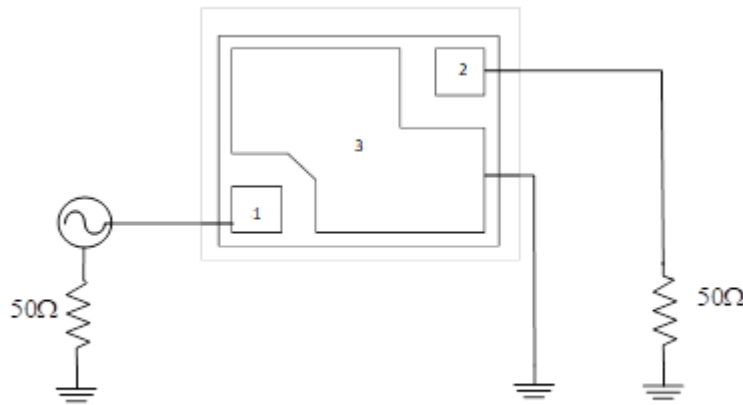
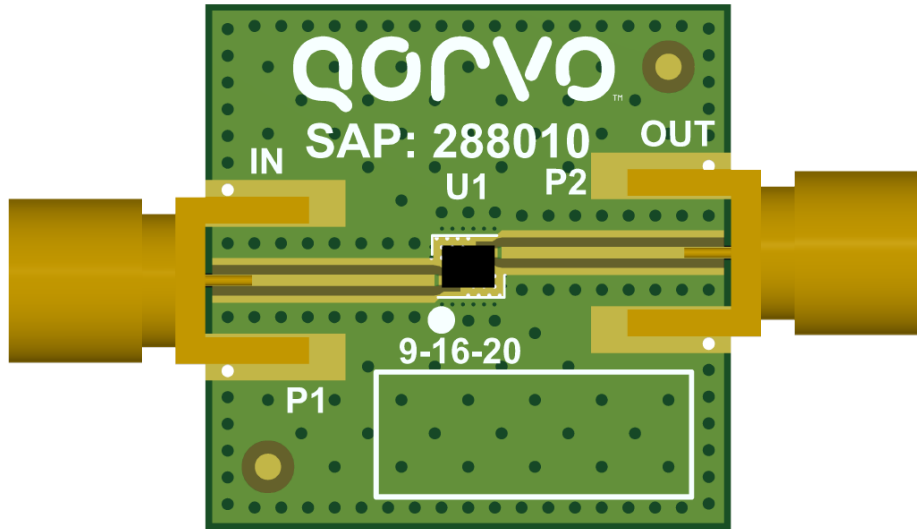

Bill of Material – QPQ3500EVB

Reference Des.	Value	Description	Manuf.	Part Number
U1	n/a	B42 200 MHz BAW Filter	Qorvo	QPQ3500
SMA	n/a	SMA Edge Connector	Various	
PCB	n/a	Printed Circuit Board	Various	

Performance Plots – Small Signal

Test conditions unless otherwise noted: Temp = +25 °C, 50 Ω system

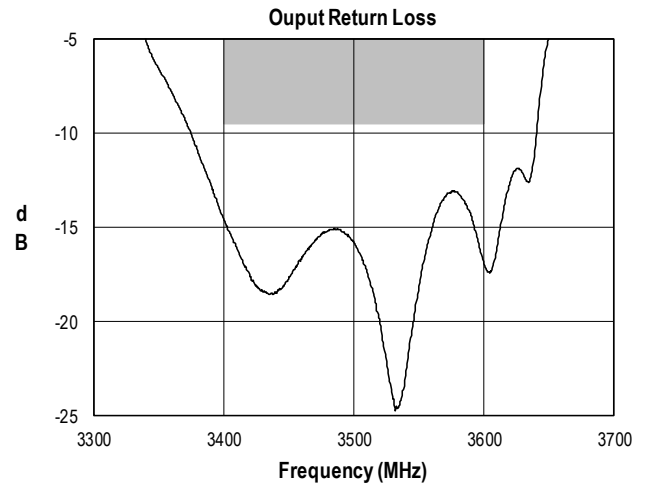
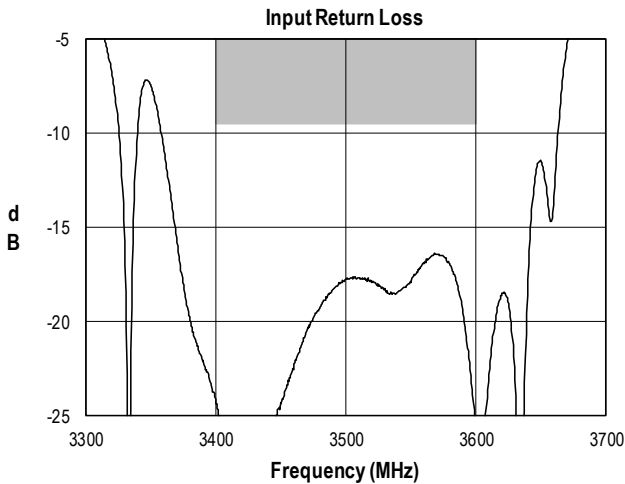
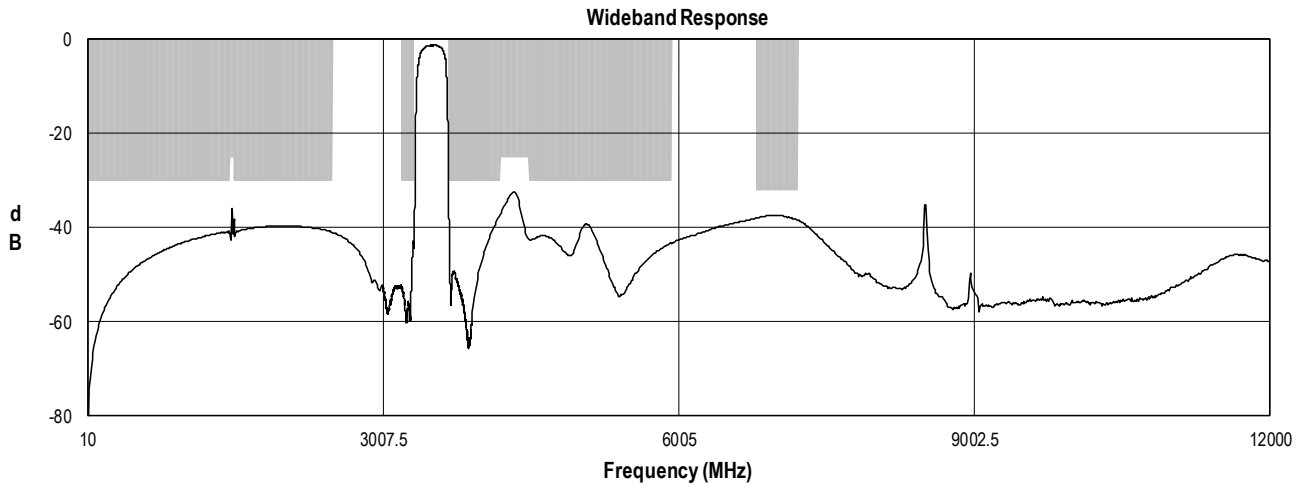
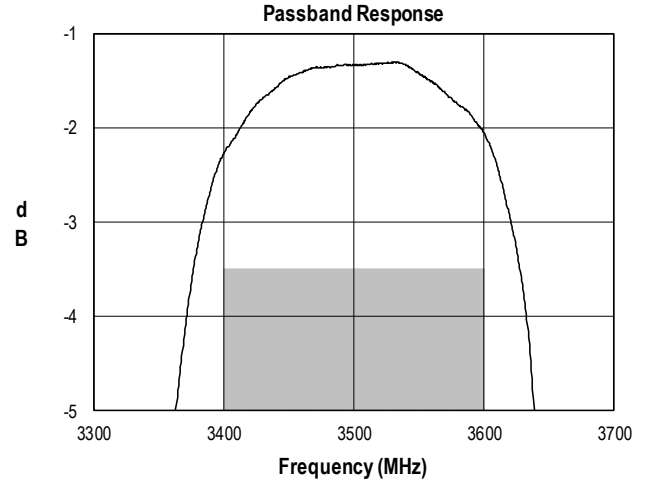
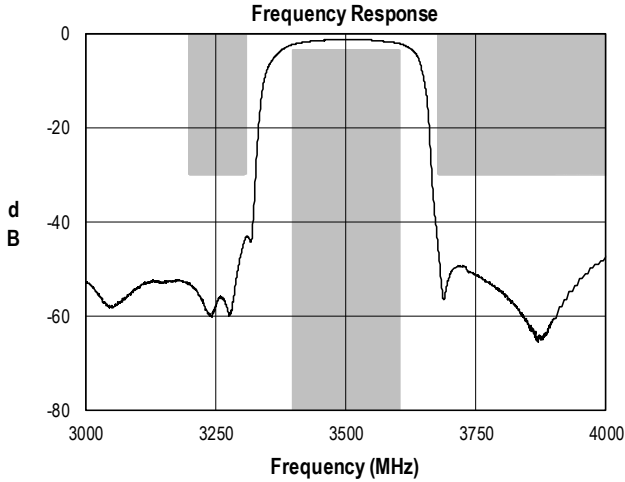

Performance Plots – Small Signal

Test conditions unless otherwise noted: Temp = +25 °C, 50 Ω system

Input Smith Chart

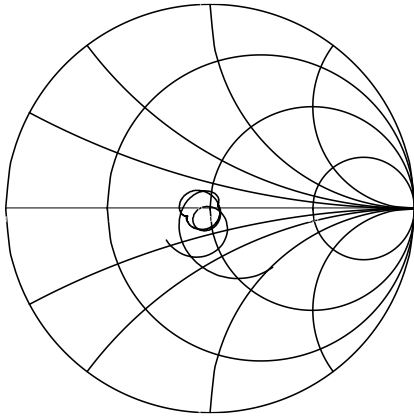

Output Smith Chart

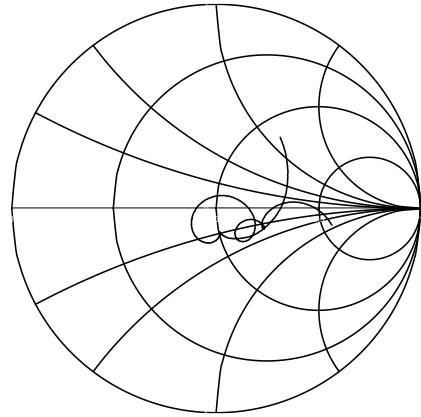

Package Marking and Dimensions

- Marking:**
- - Pin 1 Indicator
 - 3500 - Last 4-digits of part number
 - 2DID - Trace information

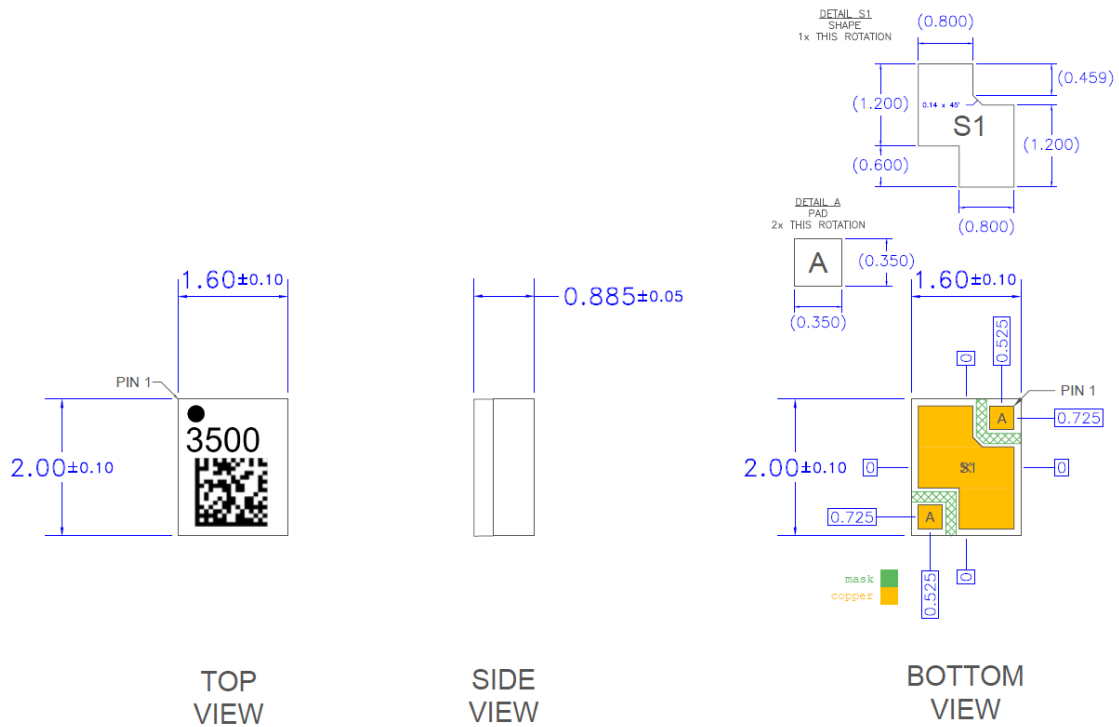

Notes:

1. All dimensions are in millimeters. Angles are in degrees.
2. Dimension and tolerance formats conform to ASME Y14.4M-1994.
3. The terminal #1 identifier and terminal numbering conform to JESD 95-1 SPP-012.

PCB Mounting Pattern

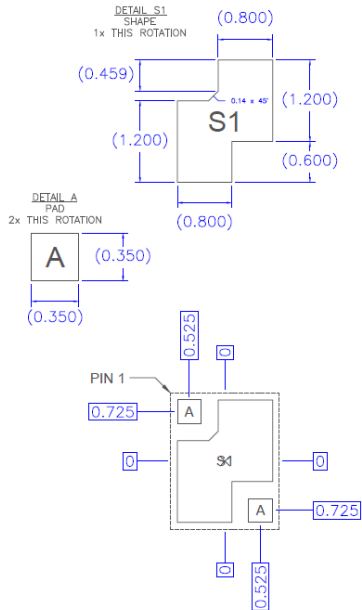

**RECOMMENDED
LAND PATTERN**

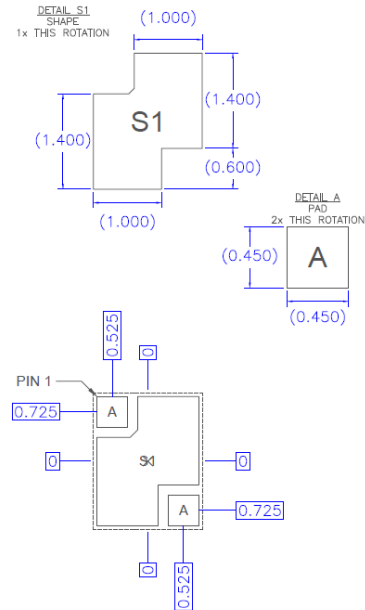

**RECOMMENDED
LAND PATTERN MASK**

Notes:

1. All dimensions are in millimeters.
2. This drawing specifies the mounting pattern used on the Qorvo evaluation board for this product. Some modification may be necessary to suit end user assembly materials and processes.

Tape and Reel Information – Carrier and Cover Tape Dimensions

Tape and reel specifications for this part are also available on the Qorvo website.
 Standard T/R size = 2500 pieces on a 7" reel.

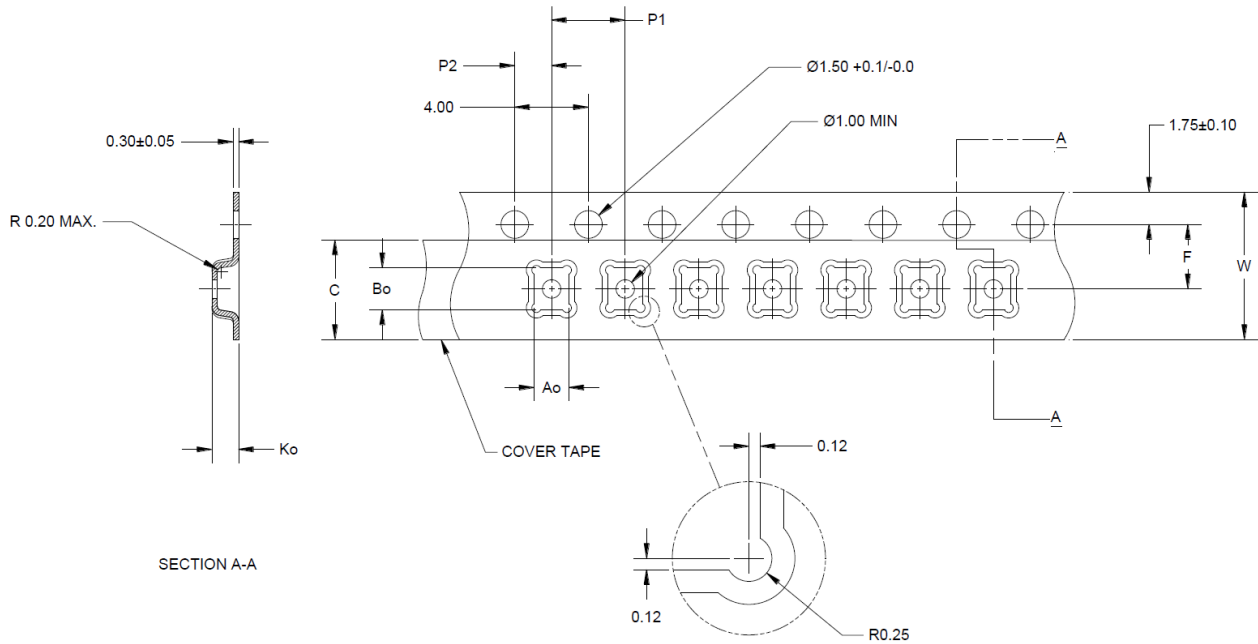

Feature	Measure	Symbol	Size (in)	Size (mm)
Cavity	Length	A0	0.077	1.95
	Width	B0	0.093	2.35
	Depth	K0	0.045	1.15
	Pitch	P1	0.157	4.00
Centerline Distance	Cavity to Perforation - Length Direction	P2	0.079	2.00
	Cavity to Perforation - Width Direction	F	0.138	3.50
Cover Tape	Width (Reference Only)	C	0.213	5.40
Carrier Tape	Width	W	0.315	8.00

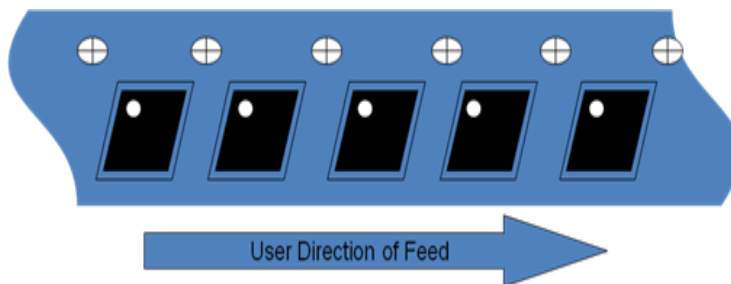

Tape and Reel Information – Reel Dimensions

Tape and reel specifications for this part are also available on the Qorvo website.
 Standard T/R size = 2500 pieces on a 7” reel.

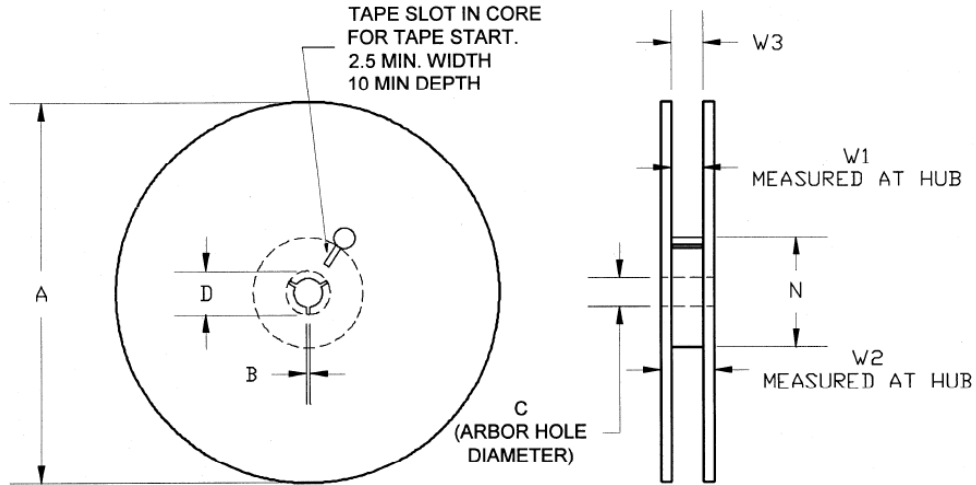

Feature	Measure	Symbol	Size (in)	Size (mm)
Flange	Diameter	A	6.969	177.0
	Thickness	W2	0.559	14.2
	Space Between Flange	W1	0.346	8.8
Hub	Outer Diameter	N	2.283	58.0
	Arbor Hole Diameter	C	0.512	13.0
	Key Slit Width	B	0.079	2.0
	Key Slit Diameter	D	0.787	20.0

Tape and Reel Information – Tape Length and Label Placement

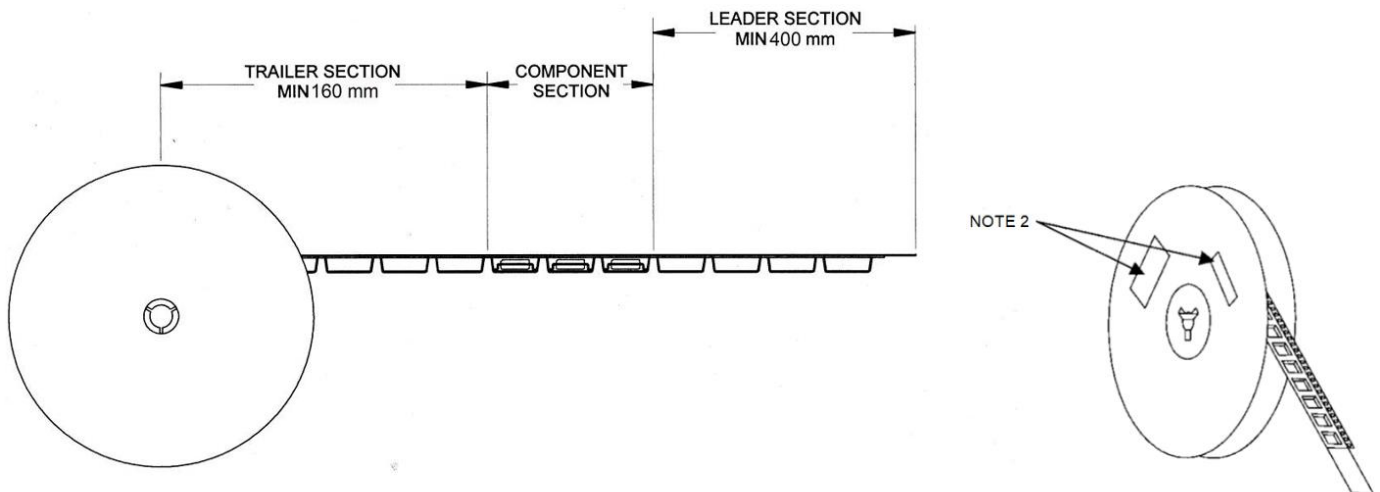

- Notes:
1. Empty part cavities at the trailing and leading ends are sealed with cover tape. See EIA 481-1-A.
 2. Labels are placed on the flange opposite the sprockets in the carrier tape.

Assembly Notes

Compatible with both lead-free (260°C peak reflow temperature) and tin/lead (245°C peak reflow temperature) soldering processes.

Contact plating: ENEPIG.

Recommended Soldering Profile

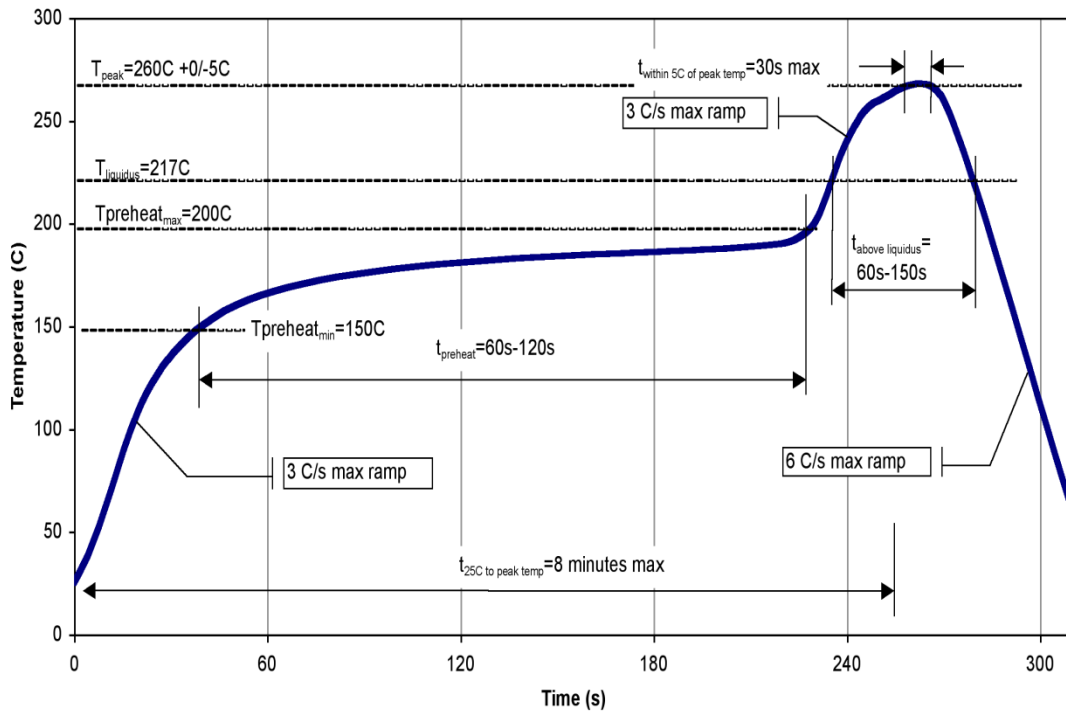

Handling Precautions

Parameter	Rating	Standard
ESD – Human Body Model (HBM)	Class 1C	ANSI / ESD / JEDEC JS-001
ESD – Charged Device Model (CDM)	Class C3	ANSI / ESD / JEDEC JS-002
MSL – Moisture Sensitivity Level	Level 3	IPC/JEDEC J-STD-020



Caution!
ESD-Sensitive Device

RoHS Compliance

This product is compliant with the 2011/65/EU RoHS directive (Restrictions on the Use of Certain Hazardous Substances in Electrical and Electronic Equipment), as amended by Directive 2015/863/EU. This product also has the following attributes:

- Lead Free
- Halogen Free (Chlorine, Bromine)
- Antimony Free
- TBBP-A (C₁₅H₁₂Br₄O₂) Free
- PFOS Free
- SVHC Free

Contact Information

For the latest specifications, additional product information, worldwide sales and distribution locations:

Web: www.qorvo.com

Tel: 1-844-890-8163

Email: customer.support@qorvo.com

Important Notice

The information contained herein is believed to be reliable; however, Qorvo makes no warranties regarding the information contained herein and assumes no responsibility or liability whatsoever for the use of the information contained herein. All information contained herein is subject to change without notice. Customers should obtain and verify the latest relevant information before placing orders for Qorvo products. The information contained herein, or any use of such information does not grant, explicitly or implicitly, to any party any patent rights, licenses, or any other intellectual property rights, whether with regard to such information itself or anything described by such information. **THIS INFORMATION DOES NOT CONSTITUTE A WARRANTY WITH RESPECT TO THE PRODUCTS DESCRIBED HEREIN, AND QORVO HEREBY DISCLAIMS ANY AND ALL WARRANTIES WITH RESPECT TO SUCH PRODUCTS WHETHER EXPRESS OR IMPLIED BY LAW, COURSE OF DEALING, COURSE OF PERFORMANCE, USAGE OF TRADE OR OTHERWISE, INCLUDING THE IMPLIED WARRANTIES OF MERCHANTABILITY AND FITNESS FOR A PARTICULAR PURPOSE.**

Without limiting the generality of the foregoing, Qorvo products are not warranted or authorized for use as critical components in medical, lifesaving, or life-sustaining applications, or other applications where a failure would reasonably be expected to cause severe personal injury or death.

Copyright 2022 © Qorvo, Inc. | Qorvo is a registered trademark of Qorvo, Inc.

Looking for pricing, stock, or lifecycle information?

Click below to explore more details on WIN SOURCE:

 [View QPQ3500TR7 on WIN SOURCE](#)

 [Qorvo US Inc. Information](#)

Optimize Your Supply Chain with WIN SOURCE Solutions

-  Global Sourcing Solution
-  Obsolete Management
-  Cost Control Management
-  Shortage Management
-  Alternative Solution
-  Excess Inventory Management