



# THE DATASHEET OF E-TDA7385

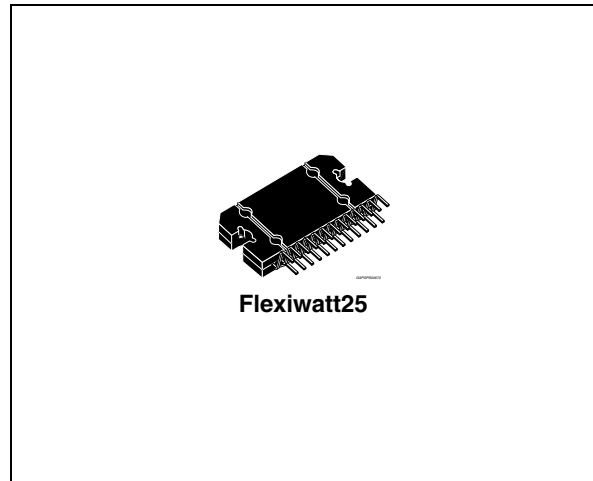


## 4 x 42 W quad bridge car radio amplifier

Datasheet – production data

### Features

- High output power capability:
  - 4 x 42 W / 4 Ω max.
  - 4 x 23 W / 4 Ω @ 14.4 V, 1 kHz, 10 %
- Clipping detector
- Low distortion
- Low output noise
- Standby function
- Mute function
- Automute at min. supply voltage detection
- Diagnostics facility for:
  - Clipping
  - Out to GND short
  - Out to  $V_S$  short
  - Thermal shutdown
- Low external component count:
  - Internally fixed gain (26 dB)
  - No external compensation
  - No bootstrap capacitors
- Protections:
  - Output short circuit to GND, to  $V_S$ , across the load
  - Very inductive loads
  - Overrating chip temperature with soft thermal limiter
  - Load dump voltage
  - Fortuitous open GND



- Reversed battery
- ESD

### Description

The TDA7385 is an AB class audio power amplifier, packaged in Flexiwatt 25 and designed for high end car radio applications.

Based on a fully complementary PNP/NPN configuration, the TDA7385 allows a rail to rail output voltage swing with no need of bootstrap capacitors. The extremely reduced boundary components count allows very compact sets.

The on-board clipping detector simplifies gain compression operations. The fault diagnostics makes it possible to detect mistakes during car-radio assembly and wiring in the car.

**Table 1. Device summary**

Order code	Package	Packing
TDA7385	Flexiwatt25	Tube
E-TDA7385 <sup>(1)</sup>	Flexiwatt25	Tube

1. Device in ECOPACK® package (see [Section 4: Package information on page 15](#)).

# Contents

- 1      Block and pin connection diagrams ..... 5**
  
- 2      Electrical specifications ..... 6**
  - 2.1 Absolute maximum ratings ..... 6
  - 2.2 Thermal data ..... 6
  - 2.3 Electrical characteristics ..... 6
  - 2.4 PCB and component layout ..... 8
  - 2.5 Electrical characteristic curves ..... 9
  
- 3      Application hints ..... 11**
  - 3.1 Biasing and SVR ..... 11
  - 3.2 Input stage ..... 11
  - 3.3 Standby and muting ..... 12
  - 3.4 Diagnostics facility ..... 12
  - 3.5 Stability and layout considerations ..... 13
  
- 4      Package information ..... 15**
  
- 5      Revision history ..... 16**

## List of tables

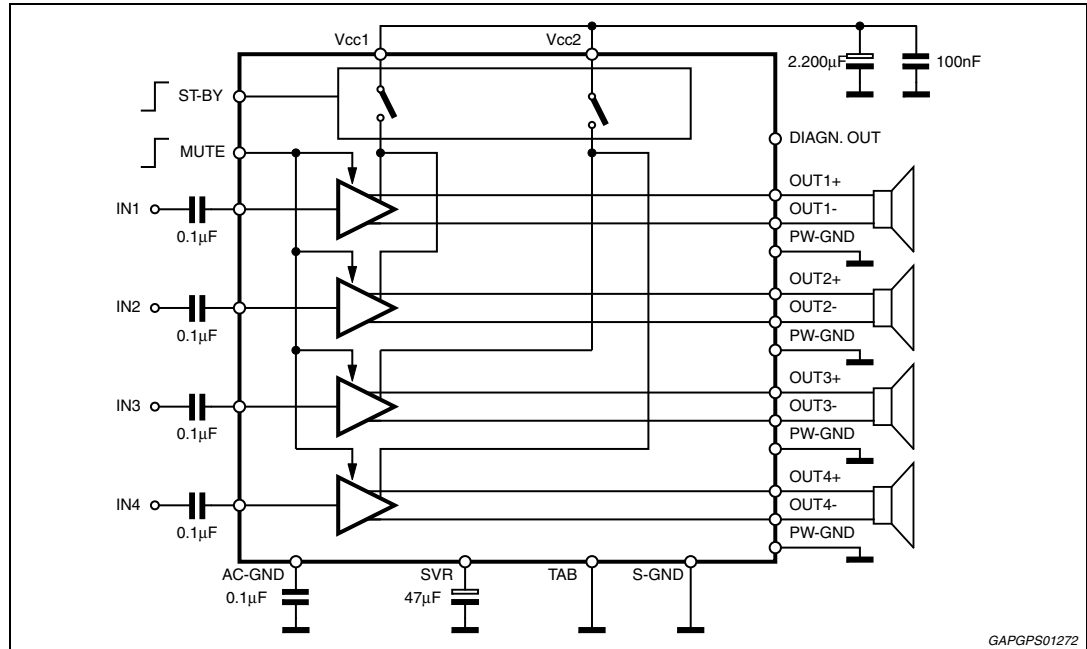
Table 1.	Device summary . . . . .	1
Table 2.	Absolute maximum ratings . . . . .	6
Table 3.	Thermal data . . . . .	6
Table 4.	Electrical characteristics . . . . .	6
Table 5.	Document revision history . . . . .	16

## List of figures

Figure 1.	Block diagram . . . . .	5
Figure 2.	Pin connection (top view) . . . . .	5
Figure 3.	Standard test and application circuit . . . . .	7
Figure 4.	Components and top copper layer . . . . .	8
Figure 5.	Bottom copper layer . . . . .	8
Figure 6.	Quiescent current vs. supply voltage . . . . .	9
Figure 7.	Quiescent output voltage vs. supply voltage . . . . .	9
Figure 8.	Output power vs. supply voltage ( $4\Omega$ ) . . . . .	9
Figure 9.	Distortion vs. output power . . . . .	9
Figure 10.	Distortion vs. frequency . . . . .	9
Figure 11.	Supply voltage rejection vs. frequency by varying C6 . . . . .	9
Figure 12.	Output noise vs. source resistance . . . . .	10
Figure 13.	Power dissipation and efficiency vs. output power . . . . .	10
Figure 14.	Input/output biasing . . . . .	11
Figure 15.	Diagnostics circuit . . . . .	12
Figure 16.	Clipping detection waveforms . . . . .	13
Figure 17.	Diagnostics waveforms . . . . .	14
Figure 18.	Fault detection circuit . . . . .	14
Figure 19.	Flexiwatt25 mechanical data and package dimensions . . . . .	15

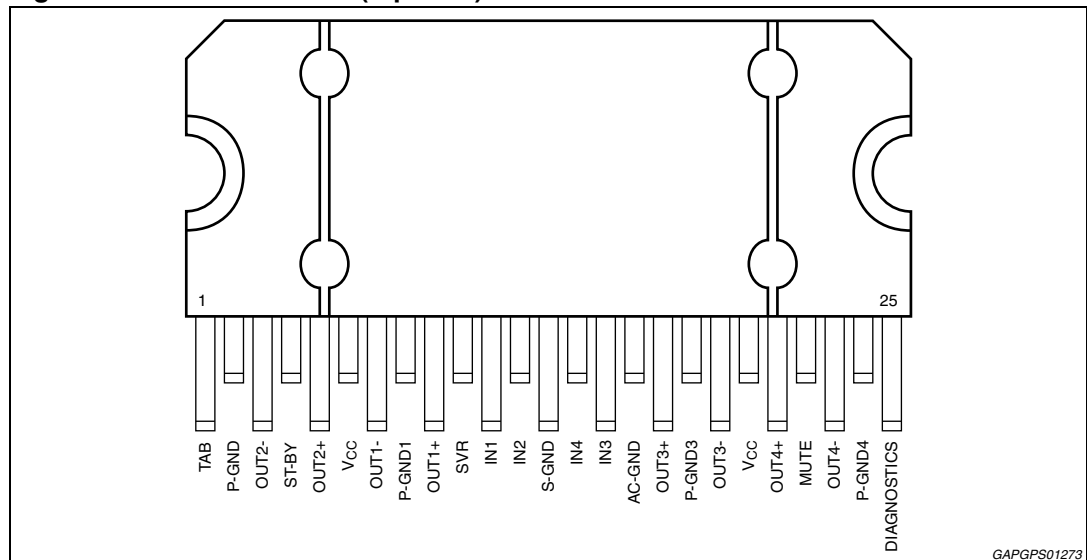
# 1 Block and pin connection diagrams

Figure 1. Block diagram



GAPGPS01272

Figure 2. Pin connection (top view)



GAPGPS01273

## 2 Electrical specifications

### 2.1 Absolute maximum ratings

Table 2. Absolute maximum ratings

Symbol	Parameter	Value	Unit
$V_S$	Operating supply voltage	18	V
$V_{S(DC)}$	DC supply voltage	28	V
$V_{S(pk)}$	Peak supply voltage (t = 50 ms)	50	V
$I_O$	Output peak current: Repetitive (duty cycle 10 % at f = 10 Hz)	4.5	A
	Non repetitive (t = 100 $\mu$ s)	5.5	A
$P_{tot}$	Power dissipation, ( $T_{case} = 70\text{ }^\circ\text{C}$ )	80	W
$T_j$	Junction temperature	150	$^\circ\text{C}$
$T_{stg}$	Storage temperature	- 55 to 150	$^\circ\text{C}$

### 2.2 Thermal data

Table 3. Thermal data

Symbol	Parameter	Value	Unit
$R_{th\ j-case}$	Thermal resistance junction-to-case max.	1	$^\circ\text{C/W}$

### 2.3 Electrical characteristics

$V_S = 14.4\text{ V}$ ; f = 1 kHz;  $R_g = 600\ \Omega$ ;  $R_L = 4\ \Omega$ ;  $T_{amb} = 25\text{ }^\circ\text{C}$ ; Refer to the test and application diagram ([Figure 3](#)), unless otherwise specified.

Table 4. Electrical characteristics

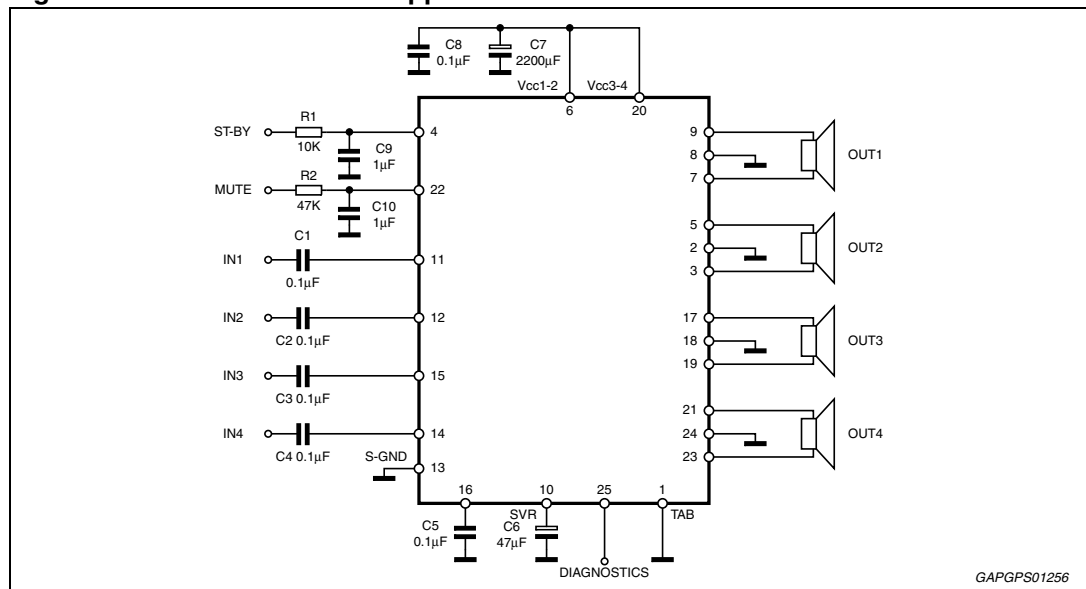
Symbol	Parameter	Test condition	Min.	Typ.	Max.	Unit
$I_{q1}$	Quiescent current	-	-	180	300	mA
$V_{OS}$	Output offset voltage	-	-	-	100	mV
$G_v$	Voltage gain	-	25	26	27	dB
$P_o$	Output power	THD = 10%	21	23	-	W
		THD = 1%	16.5	19	-	
		THD = 10%; $V_S = 13.2\text{ V}$	17	20	-	
		THD = 1%; $V_S = 13.2\text{ V}$	14	16	-	
$P_{o\ max.}$	Max. output power <sup>(1)</sup>	$V_S = 14.4\text{ V}$	33	35	-	W
		$V_S = 15.2\text{ V}$	-	42	-	W
THD	Distortion	$P_o = 4\text{ W}$	-	0.04	0.3	%

Table 4. Electrical characteristics (continued)

Symbol	Parameter	Test condition	Min.	Typ.	Max.	Unit
$e_{No}$	Output noise	"A" Weighted	-	50	-	$\mu V$
		Bw = 20 Hz to 20 kHz	-	65	150	$\mu V$
SVR	Supply voltage rejection	f = 100 Hz	50	65	-	dB
$f_{cl}$	Low cut-off frequency	-	-	20	-	Hz
$f_{ch}$	High cut-off frequency	-	75	-	-	kHz
$R_i$	Input impedance	-	70	100	-	k $\Omega$
$C_T$	Cross talk	f = 1 kHz	50	70	-	dB
$I_{SB}$	Standby current consumption	$V_{standby} = 0 V$	-	-	15	$\mu A$
$V_{SB out}$	Standby out threshold voltage	(Amp: on)	3.5	-	-	V
$V_{SB in}$	Standby in threshold voltage	(Amp: off)	-	-	1.5	V
$A_M$	Mute attenuation	$V_O = 1V_{rms}$	80	90	-	dB
$V_{M out}$	Mute out threshold voltage	(Amp: play)	3.5	-	-	V
$V_{M in}$	Mute in threshold voltage	(Amp: mute)	-	-	1.5	V
$I_m (L)$	Muting pin current	$V_{MUTE} = 1.5V$ (source current)	5	10	16	$\mu A$
$I_{CDOFF}$	Clipping detector "off" output average current	THD = 1% (1)	-	100	-	$\mu A$
$I_{CDON}$	Clipping detector "on" output average current	THD = 10% (1)	100	240	350	$\mu A$

1. Diagnostics output pulled-up to 5 V with 10 k $\Omega$  series resistor.

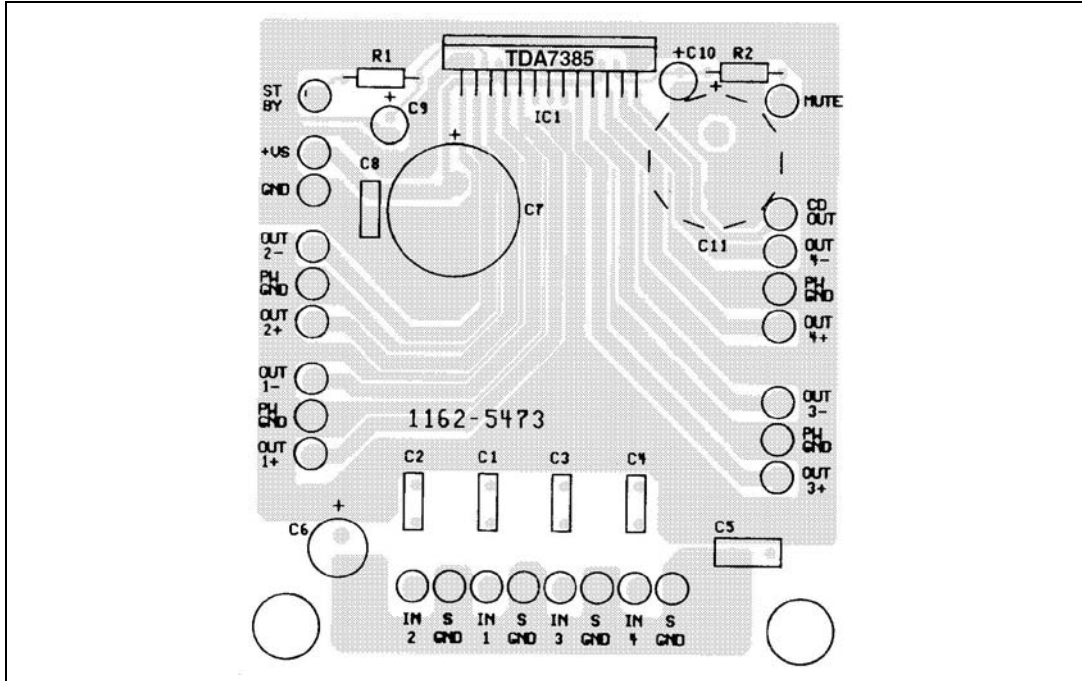
Figure 3. Standard test and application circuit



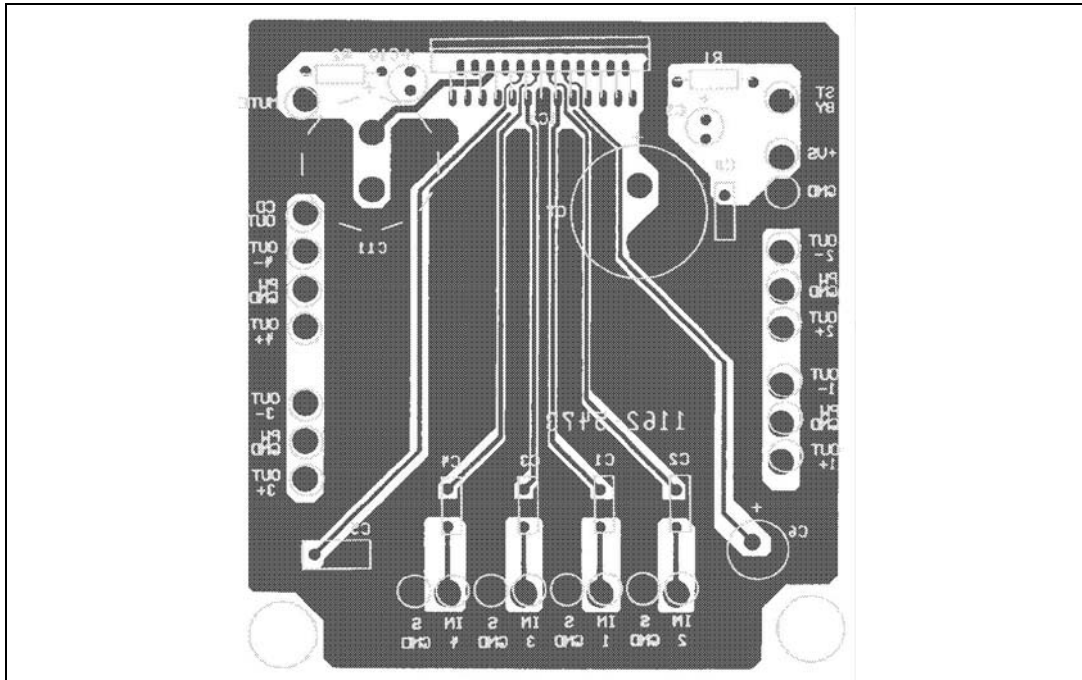
## 2.4 PCB and component layout

Referred to [Figure 3: Standard test and application circuit](#).

**Figure 4. Components and top copper layer**

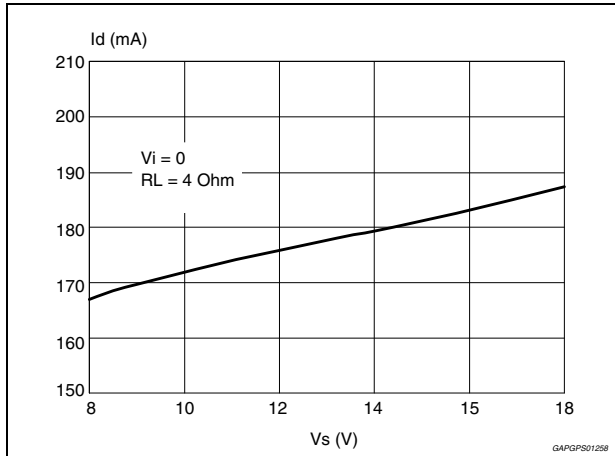


**Figure 5. Bottom copper layer**

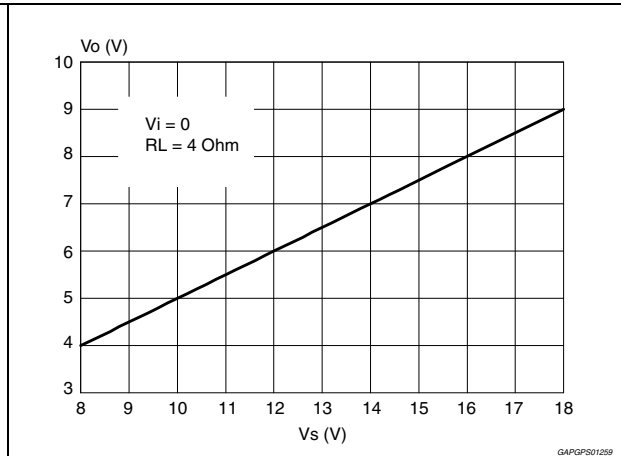


## 2.5 Electrical characteristic curves

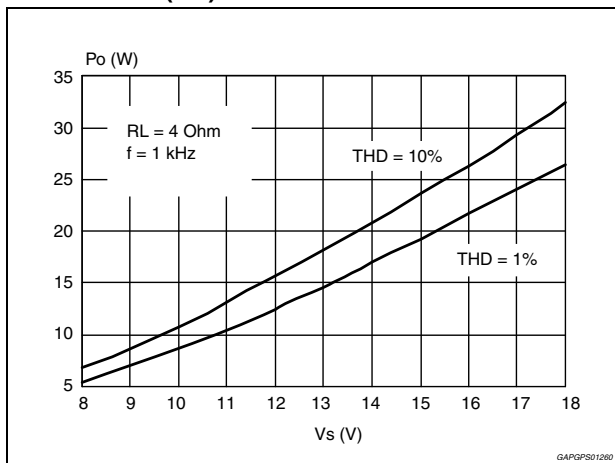
**Figure 6. Quiescent current vs. supply voltage**



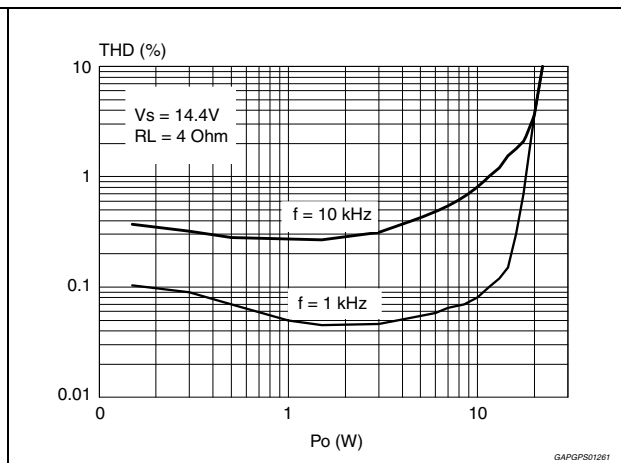
**Figure 7. Quiescent output voltage vs. supply voltage**



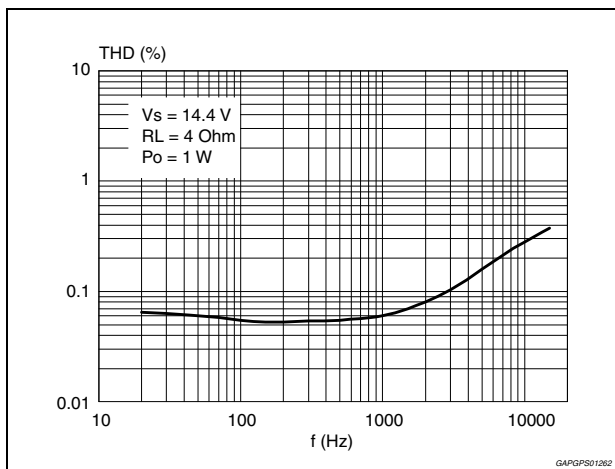
**Figure 8. Output power vs. supply voltage (4Ω)**



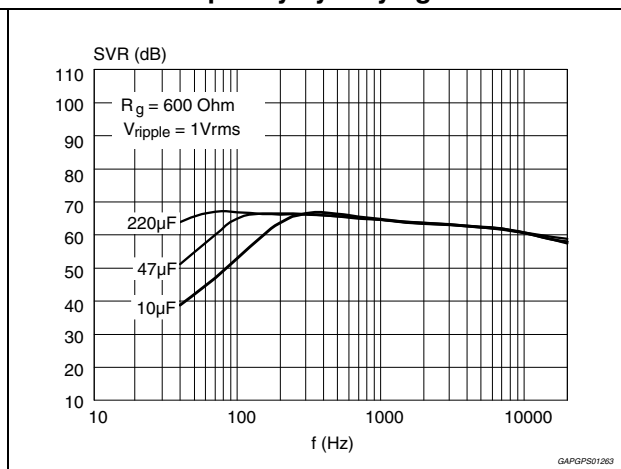
**Figure 9. Distortion vs. output power**



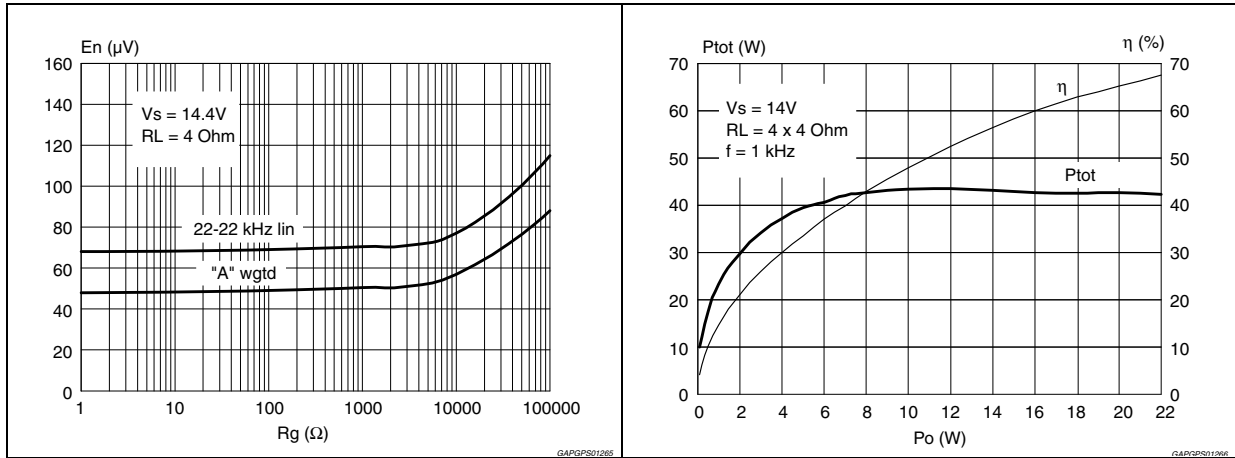
**Figure 10. Distortion vs. frequency**



**Figure 11. Supply voltage rejection vs. frequency by varying C6**



**Figure 12. Output noise vs. source resistance**    **Figure 13. Power dissipation and efficiency vs. output power**



### 3 Application hints

Referred to the circuit of [Figure 3](#).

#### 3.1 Biasing and SVR

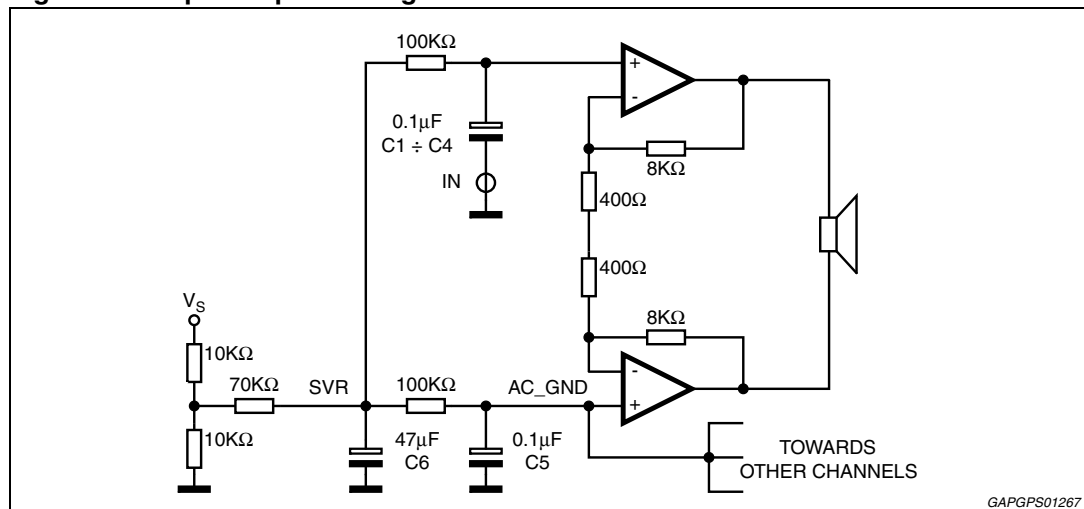
As shown by [Figure 14](#), all the TDA7385's main sections, such as Inputs, Outputs AND AC-GND (pin 16) are internally biased at half supply voltage level ( $V_s/2$ ), which is derived from the Supply Voltage Rejection (SVR) block. In this way no current flows through the internal feedback network. The AC-GND is common to all the 4 amplifiers and represents the connection point of all the inverting inputs.

Both individual inputs and AC-GND are connected to  $V_s/2$  (SVR) by means of 100 k $\Omega$  resistors.

To ensure proper operation and high supply voltage rejection, it is of fundamental importance to provide a good impedance matching between Inputs and AC-GROUND terminations. This implies that **C<sub>1</sub>, C<sub>2</sub>, C<sub>3</sub>, C<sub>4</sub>, C<sub>5</sub> capacitors have to carry the same nominal value and their tolerance should never exceed  $\pm 10\%$** .

Besides its contribution to the ripple rejection, the SVR capacitor governs the turn ON/OFF time sequence and, consequently, plays an essential role in the pop optimization during ON/OFF transients. To conveniently serve both needs, **its minimum recommended value is 10 $\mu$ F**.

**Figure 14. Input/output biasing**



#### 3.2 Input stage

The TDA7385's inputs are ground-compatible and can stand very high input signals ( $\pm 8$  Vpk) without any performances degradation.

If the standard value for the input capacitors (0.1  $\mu$ F) is adopted, the low frequency cut-off will amount to 16 Hz.

### 3.3 Standby and muting

Standby and muting facilities are both CMOS-compatible. If unused, a straight connection to  $V_s$  of their respective pins would be admissible. Conventional low-power transistors can be employed to drive muting and stand-by pins in absence of true CMOS ports or microprocessors. R-C cells have always to be used in order to smooth down the transitions for preventing any audible transient noises.

Since a DC current of about  $10\ \mu\text{A}$  normally flows out of pin 22, the maximum allowable muting-series resistance ( $R_2$ ) is  $70\ \text{k}\Omega$ , which is sufficiently high to permit a muting capacitor reasonably small (about  $1\ \mu\text{F}$ ).

If  $R_2$  is higher than recommended, the involved risk will be that the voltage at pin 22 may rise to above the  $1.5\ \text{V}$  threshold voltage and the device will consequently fail to turn OFF when the mute line is brought down.

About the stand-by, the time constant to be assigned in order to obtain a virtually pop-free transition has to be slower than  $2.5\ \text{V/ms}$ .

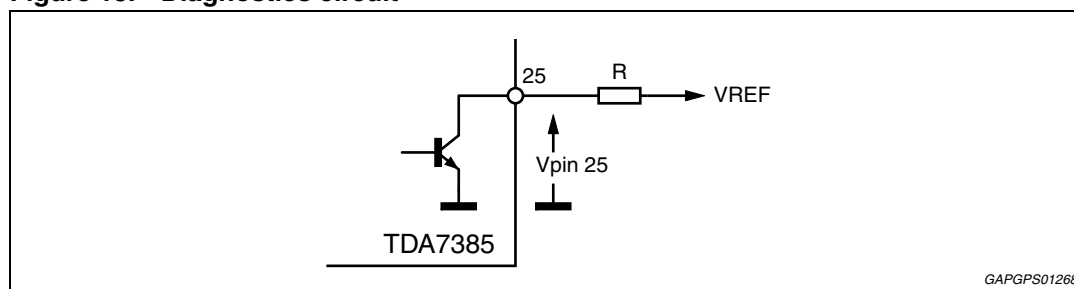
### 3.4 Diagnostics facility

The TDA7385 is equipped with a diagnostics circuitry able to detect the following events:

- Clipping in the output stage
- overheating (thermal shut-down proximity)
- Output misconnections (OUT-GND and OUT- $V_s$  shorts)

Diagnostics information is available across an open collector output located at pin 25 ([Figure 15](#)) through a current sinking whenever at least one of the above events is recognized.

**Figure 15. Diagnostics circuit**



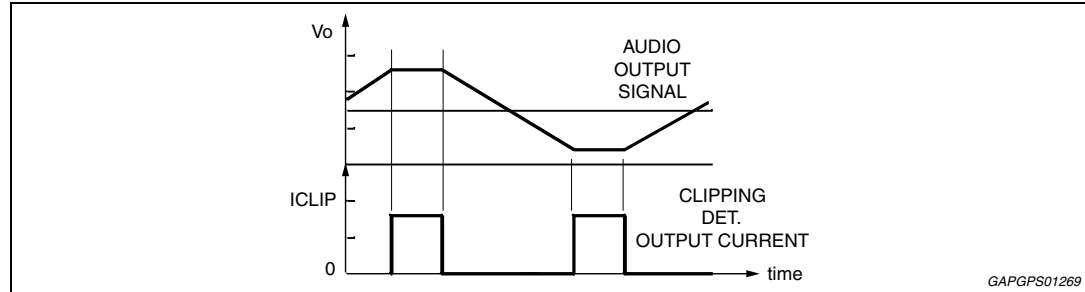
Among them, the **Clipping Detector** acts in a way to output a signal as soon as one or more power transistors start being saturated.

As a result, the clipping-related signal at pin 25 takes the form of pulses, which are perfectly synchronized with each single clipping event in the music program and reflect the same duration time ([Figure 16](#)). Applications making use of this facility usually operate a filtering/integration of the pulses train through passive R-C networks and realize a volume (or tone bass) stepping down in association with microprocessor-driven audioprocessors. The maximum load that pin 25 can sustain is  $1\ \text{k}\Omega$ .

Due to its operating principles, the clipping detector has to be viewed mainly as a power-dependent feature rather than frequency-dependent. This means that clipping state will be immediately signaled out whenever a fixed power level is reached, regardless of the audio

frequency. In other words, this feature offers the means to counteract the extremely sound-damaging effects of clipping, caused by a sudden increase of odd order harmonics and appearance of serious inter-modulation phenomena.

**Figure 16. Clipping detection waveforms**



Another possible kind of distortion control could be the setting of a maximum allowable THD limit (e.g. 0.5%) over the entire audio frequency range. Besides offering no practical advantages, this procedure cannot be much accurate, as the non-clipping distortion is likely to vary over frequency.

In case of **Overheating**, pin 25 will signal out the junction temperature proximity to the thermal shut-down threshold. This will typically start about 2°C before the thermal shut-down threshold is reached.

As various kind of diagnostics information is available at pin 25 (clipping, shorts and overheating), it may be necessary to operate some distinctions in order to treat each event separately. This could be achieved by taking into account the intrinsically different timing of the diagnostics output under each circumstance.

In fact, clipping will produce pulses normally much shorter than those present under faulty conditions. An example of circuit able to distinguish between the two occurrences is shown by [Figure 18](#).

### 3.5 Stability and layout considerations

If properly layouted and hooked to standard car-radio speakers, the TDA7385 will be intrinsically stable with no need of external compensations such as output R-C cells. Due to the high number of channels involved, this translates into a very remarkable components saving if compared to similar devices on the market.

To simplify pc-board layout designs, each amplifier stage has its own power ground externally accessible (pins 2,8,18,24) and one supply voltage pin for each couple of them. Even more important, this makes it possible to achieve the highest possible degree of separation among the channels, with remarkable benefits in terms of cross-talk and distortion features.

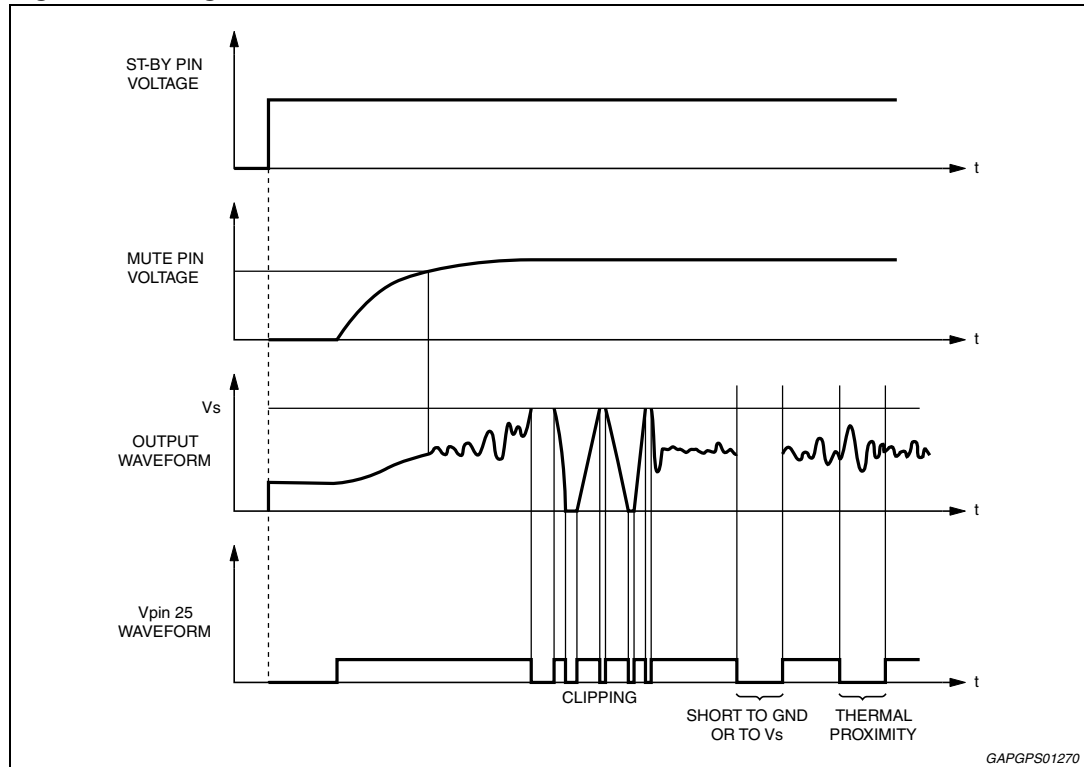
About the layout grounding, it is particularly important to connect the AC-GND capacitor ( $C_5$ ) to the signal GND, as close as possible to the audio inputs ground: this will guarantee high rejection of any common mode spurious signals.

The SVR capacitor ( $C_6$ ) has also to be connected to the signal GND.

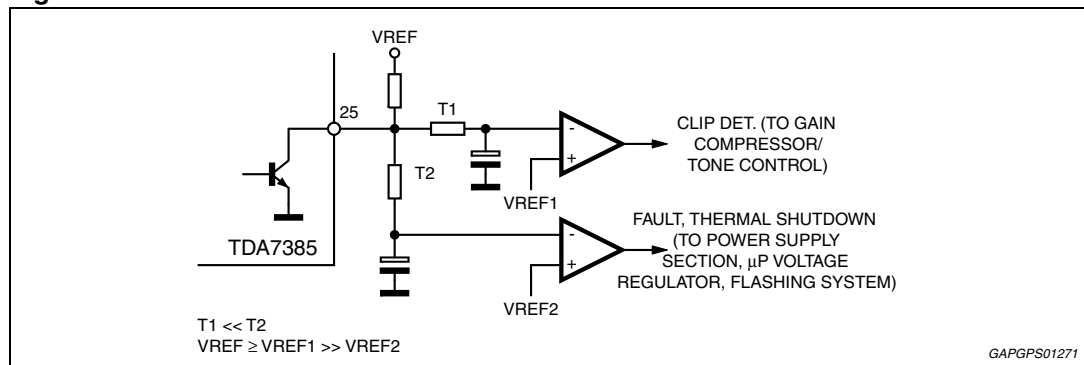
Supply filtering elements ( $C_7$ ,  $C_8$ ) have naturally to be connected to the power-ground and located as close as possible to the Vs pins.

Pin 1, which is mechanically attached to the device's tab, needs to be tied to the cleanest power ground point in the pc-board, which is generally near the supply filtering capacitors.

**Figure 17. Diagnostics waveforms**



**Figure 18. Fault detection circuit**

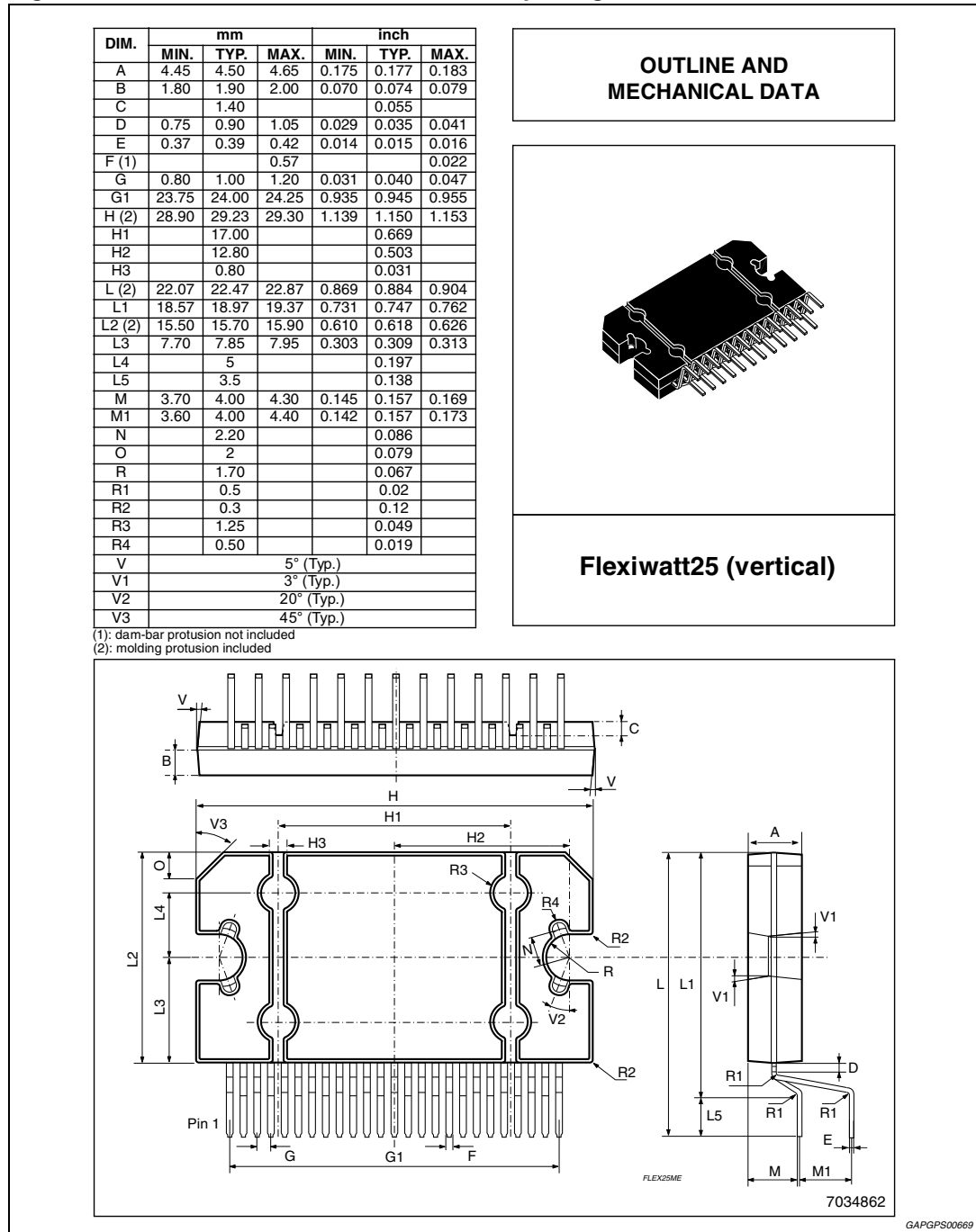


# 4 Package information

In order to meet environmental requirements, ST offers these devices in different grades of ECOPACK® packages, depending on their level of environmental compliance. ECOPACK® specifications, grade definitions and product status are available at: [www.st.com](http://www.st.com).

ECOPACK® is an ST trademark.

**Figure 19. Flexiwatt25 mechanical data and package dimensions**



## 5 Revision history

**Table 5. Document revision history**

Date	Revision	Changes
10-Mar-2001	1	Initial release.
13-Nov-2008	2	Document reformatted. Added <a href="#">Features on page 1</a> . Updated <a href="#">Table 4: Electrical characteristics on page 6</a> . Updated <a href="#">Section 4: Package information on page 15</a> .
09-Jan-2012	3	Modified <a href="#">Features on page 1</a> ; Updated <a href="#">Table 4: Electrical characteristics</a> .
14-Jun-2012	4	Updated <a href="#">Features on page 1</a> ; Updated <a href="#">Table 4: Electrical characteristics</a> .
26-Jul-2012	5	Updated <a href="#">Figure 17: Diagnostics waveforms on page 14</a> .
16-Sep-2013	6	Updated Disclaimer.

**Please Read Carefully:**

Information in this document is provided solely in connection with ST products. STMicroelectronics NV and its subsidiaries ("ST") reserve the right to make changes, corrections, modifications or improvements, to this document, and the products and services described herein at any time, without notice.

All ST products are sold pursuant to ST's terms and conditions of sale.

Purchasers are solely responsible for the choice, selection and use of the ST products and services described herein, and ST assumes no liability whatsoever relating to the choice, selection or use of the ST products and services described herein.

No license, express or implied, by estoppel or otherwise, to any intellectual property rights is granted under this document. If any part of this document refers to any third party products or services it shall not be deemed a license grant by ST for the use of such third party products or services, or any intellectual property contained therein or considered as a warranty covering the use in any manner whatsoever of such third party products or services or any intellectual property contained therein.

**UNLESS OTHERWISE SET FORTH IN ST'S TERMS AND CONDITIONS OF SALE ST DISCLAIMS ANY EXPRESS OR IMPLIED WARRANTY WITH RESPECT TO THE USE AND/OR SALE OF ST PRODUCTS INCLUDING WITHOUT LIMITATION IMPLIED WARRANTIES OF MERCHANTABILITY, FITNESS FOR A PARTICULAR PURPOSE (AND THEIR EQUIVALENTS UNDER THE LAWS OF ANY JURISDICTION), OR INFRINGEMENT OF ANY PATENT, COPYRIGHT OR OTHER INTELLECTUAL PROPERTY RIGHT.**

**ST PRODUCTS ARE NOT DESIGNED OR AUTHORIZED FOR USE IN: (A) SAFETY CRITICAL APPLICATIONS SUCH AS LIFE SUPPORTING, ACTIVE IMPLANTED DEVICES OR SYSTEMS WITH PRODUCT FUNCTIONAL SAFETY REQUIREMENTS; (B) AERONAUTIC APPLICATIONS; (C) AUTOMOTIVE APPLICATIONS OR ENVIRONMENTS, AND/OR (D) AEROSPACE APPLICATIONS OR ENVIRONMENTS. WHERE ST PRODUCTS ARE NOT DESIGNED FOR SUCH USE, THE PURCHASER SHALL USE PRODUCTS AT PURCHASER'S SOLE RISK, EVEN IF ST HAS BEEN INFORMED IN WRITING OF SUCH USAGE, UNLESS A PRODUCT IS EXPRESSLY DESIGNATED BY ST AS BEING INTENDED FOR "AUTOMOTIVE, AUTOMOTIVE SAFETY OR MEDICAL" INDUSTRY DOMAINS ACCORDING TO ST PRODUCT DESIGN SPECIFICATIONS. PRODUCTS FORMALLY ESCC, QML OR JAN QUALIFIED ARE DEEMED SUITABLE FOR USE IN AEROSPACE BY THE CORRESPONDING GOVERNMENTAL AGENCY.**

Resale of ST products with provisions different from the statements and/or technical features set forth in this document shall immediately void any warranty granted by ST for the ST product or service described herein and shall not create or extend in any manner whatsoever, any liability of ST.

ST and the ST logo are trademarks or registered trademarks of ST in various countries.

Information in this document supersedes and replaces all information previously supplied.

The ST logo is a registered trademark of STMicroelectronics. All other names are the property of their respective owners.

© 2013 STMicroelectronics - All rights reserved



STMicroelectronics group of companies

Australia - Belgium - Brazil - Canada - China - Czech Republic - Finland - France - Germany - Hong Kong - India - Israel - Italy - Japan - Malaysia - Malta - Morocco - Philippines - Singapore - Spain - Sweden - Switzerland - United Kingdom - United States of America

[www.st.com](http://www.st.com)

## Looking for pricing, stock, or lifecycle information?

Click below to explore more details on WIN SOURCE:

-  [View E-TDA7385](#) on WIN SOURCE
-  [STMicroelectronics](#) Information

## Optimize Your Supply Chain with WIN SOURCE Solutions

-  Global Sourcing Solution
-  Obsolete Management
-  Cost Control Management
-  Shortage Management
-  Alternative Solution
-  Excess Inventory Management