



**THE DATASHEET OF
ETC1-1-13TR**



Features

- Surface Mount
- 1:1 impedance ratio
- Available on Tape and Reel
- RoHS Compliant and Pb Free
- 260°C Reflow Compatible
- Available on Tape and Reel

Description

The ETC1-1-13 is a 1:1 transmission line transformer in a low cost surface mount package.

Ideally suited for high volume cellular and wireless applications.

Functional Schematic

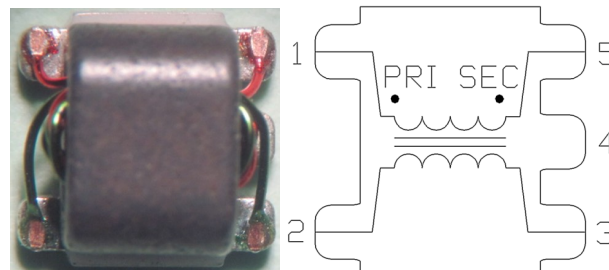

Pin Configuration

Pin No.	Function
1	Primary Dot
2	Primary
3	Secondary
4	Not Connected (ground)
5	Secondary Dot

Electrical Specifications: Freq. = 4.5 - 3000 MHz, T_A = 25°C, Z₀ = 50 Ω, P_{IN} = 0 dBm

Parameter	Conditions	Units	Min.	Typ.	Max.
Insertion Loss (Ref. level -3 dB)	4.5 - 1000 MHz	dB	-	0.32	1.0
	1000 - 2000 MHz			-	2.0
	2000 - 3000 MHz			-	3.5
Amplitude Balance	-	dB	-	-	±1.0
Phase Balance (Ref. value 0°)	-	degree	-	-	±20

Ordering Information

Part Number	Description
ETC1-1-13TR	2000 piece reel

Recommended Maximum Ratings

Parameter	Units
Input RF Power	250 mW
DC Current	30 mA
Operating Temperature	-55°C to +85°C

E-Series Transformer, RF 1:1 Transmission Line 4.5 - 3000 MHz

Rev. V12

Typical Performance Curves: $T_A = 25^\circ\text{C}$, $Z_0 = 50 \Omega$, $P_{IN} = 0 \text{ dBm}$

Insertion Loss

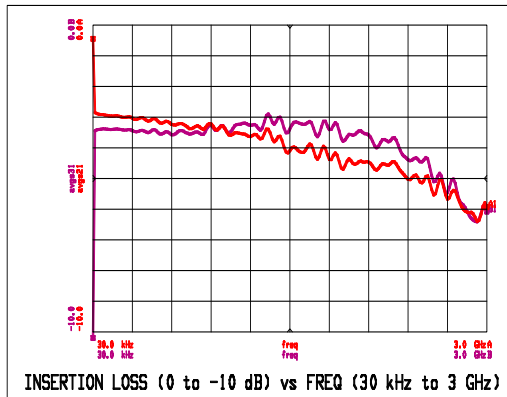

Input Impedance

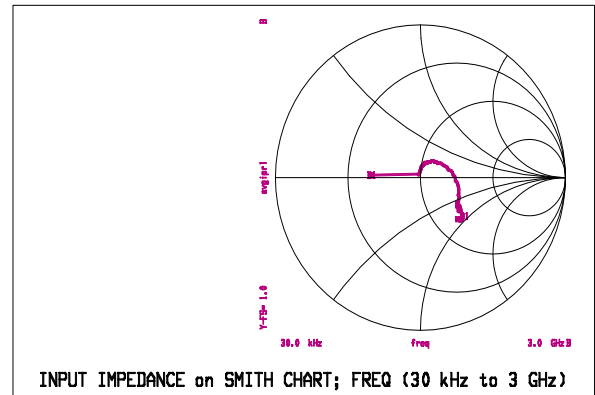

Phase Unbalance

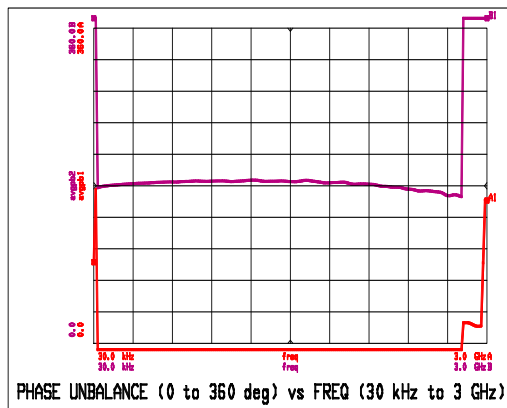

Amplitude Unbalance

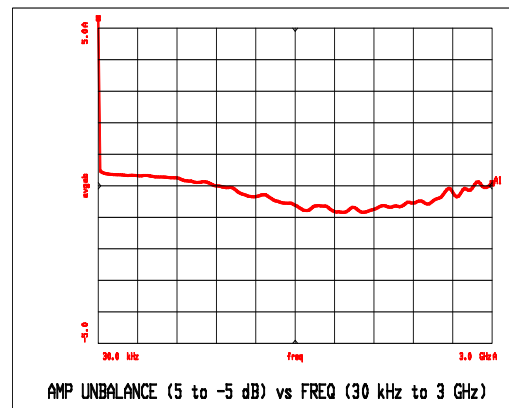

Full temperature plots available on request

Recommended Board Layout / Footprint²

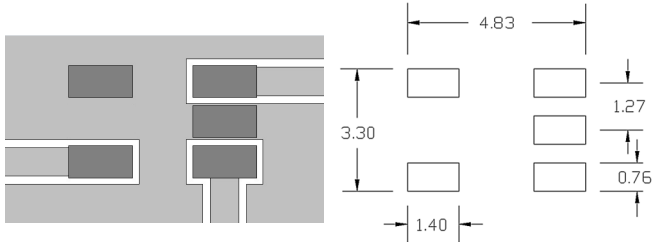

2. Recommended PCB layout shown uses 0.8 mm FR4, grounded coplanar wave guide, transmission line width 0.90 mm and gap 0.25 mm.

Outline Drawing^{3,4,5,6}

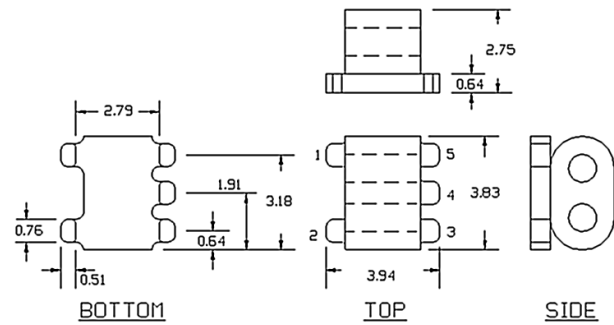

- 3. Dimensions in mm.
- 4. Tolerance: ± 0.2 mm unless otherwise noted.
- 5. Model number and lot code are printed on the reel.
- 6. Lead finish: Sn.

Application Circuit

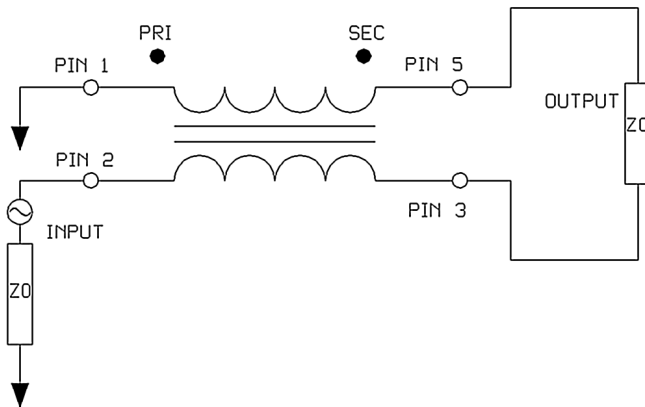

Carrier Tape Orientation

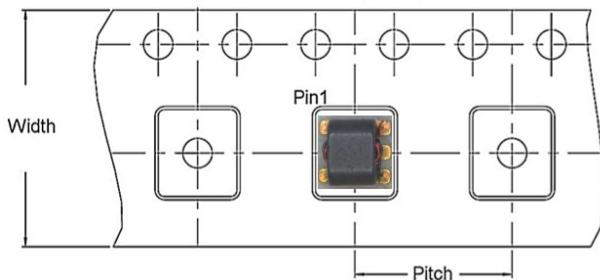

Tape & Reel Information

Parameter	Units	Value
Qty per reel	-	2000
Reel Size	mm	330
Width	mm	12.0
Pitch	mm	8.0
Orientation	-	F5
Reference Application Note ANI-019 for orientation		

MACOM Technology Solutions Inc. All rights reserved.

Information in this document is provided in connection with MACOM Technology Solutions Inc ("MACOM") products. These materials are provided by MACOM as a service to its customers and may be used for informational purposes only. Except as provided in MACOM's Terms and Conditions of Sale for such products or in any separate agreement related to this document, MACOM assumes no liability whatsoever. MACOM assumes no responsibility for errors or omissions in these materials. MACOM may make changes to specifications and product descriptions at any time, without notice. MACOM makes no commitment to update the information and shall have no responsibility whatsoever for conflicts or incompatibilities arising from future changes to its specifications and product descriptions. No license, express or implied, by estoppel or otherwise, to any intellectual property rights is granted by this document.

THESE MATERIALS ARE PROVIDED "AS IS" WITHOUT WARRANTY OF ANY KIND, EITHER EXPRESS OR IMPLIED, RELATING TO SALE AND/OR USE OF MACOM PRODUCTS INCLUDING LIABILITY OR WARRANTIES RELATING TO FITNESS FOR A PARTICULAR PURPOSE, CONSEQUENTIAL OR INCIDENTAL DAMAGES, MERCHANTABILITY, OR INFRINGEMENT OF ANY PATENT, COPYRIGHT OR OTHER INTELLECTUAL PROPERTY RIGHT. MACOM FURTHER DOES NOT WARRANT THE ACCURACY OR COMPLETENESS OF THE INFORMATION, TEXT, GRAPHICS OR OTHER ITEMS CONTAINED WITHIN THESE MATERIALS. MACOM SHALL NOT BE LIABLE FOR ANY SPECIAL, INDIRECT, INCIDENTAL, OR CONSEQUENTIAL DAMAGES, INCLUDING WITHOUT LIMITATION, LOST REVENUES OR LOST PROFITS, WHICH MAY RESULT FROM THE USE OF THESE MATERIALS.

MACOM products are not intended for use in medical, lifesaving or life sustaining applications. MACOM customers using or selling MACOM products for use in such applications do so at their own risk and agree to fully indemnify MACOM for any damages resulting from such improper use or sale.

Looking for pricing, stock, or lifecycle information?

Click below to explore more details on WIN SOURCE:

- ⊖ [View ETC1-1-13TR on WIN SOURCE](#)
- ⊖ [M/A-Com Technology Solutions Information](#)

Optimize Your Supply Chain with WIN SOURCE Solutions

- ✓ Global Sourcing Solution
- ✓ Obsolete Management
- ✓ Cost Control Management
- ✓ Shortage Management
- ✓ Alternative Solution
- ✓ Excess Inventory Management