



**THE DATASHEET OF
ESDA14V2-4BF2**



Quad bidirectional Transil™ array for ESD protection

Features

- 4 Bidirectional Transil functions
- ESD Protection: IEC 61000-4-2 level 4
- Stand off voltage: 12 V Min.
- Low leakage current < 1 μ A
- 50 W Peak pulse power (8/20 μ s)

Benefits

- High ESD protection level
- High integration
- Suitable for high density boards

Complies with the following standards

- IEC 61000-4-2
 - 15 kV (air discharge)
 - 8 kV (contact discharge)
- MIL STD 883F- Method 3015-7: class3
 - 25 kV (human body model)

Applications

Where transient overvoltage protection in ESD sensitive equipment is required, such as :

- Computers
- Printers
- Communication systems and cellular phones
- Video equipment

Description

The ESDA14V2-4BF2 is a monolithic array designed to protect up to 4 lines (bidirectional) against ESD transients.

This device is particularly adapted to the protection of symmetrical signals.

The device is ideal for situations where board space saving is requested.

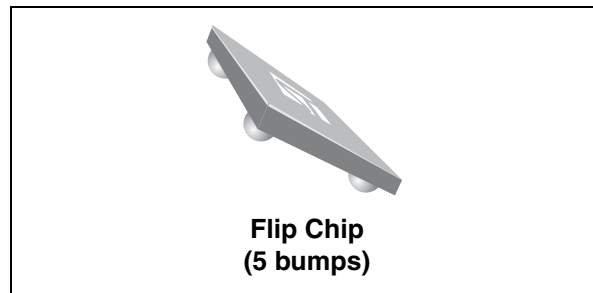

Figure 1. Device configuration

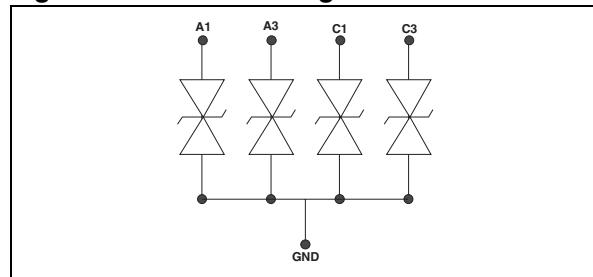
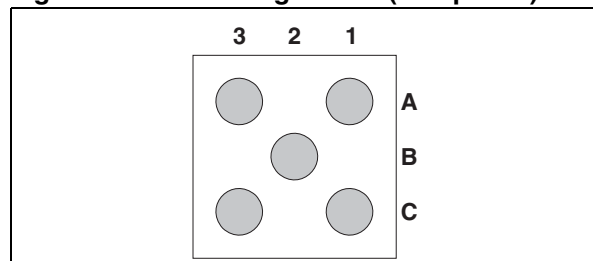

Figure 2. Pin configuration (bump side)



™: Transil is a trademark of STMicroelectronics.

1 Characteristics

Table 1. Absolute ratings (limiting values)

Symbol	Parameter		Value	Unit
V _{PP}	ESD discharge	MIL STD 883E - Method 3015-7 IEC61000-4-2 air discharge IEC61000-4-2 contact discharge	± 25 ± 15 ± 8	kV
P _{PP}	Peak pulse power (8/20 μs)		50	W
T _j	Junction temperature		125	°C
T _{stg}	Storage temperature range		-55 to +150	°C
T _L	Lead solder temperature (10 seconds duration)		260	°C
T _{op}	Operating temperature range		-40 to +125	°C

Table 2. Electrical characteristics (T_{amb} = 25 °C)

Symbol	Parameter							
V _{RM}	Stand-off voltage							
V _{BR}	Breakdown voltage							
V _{CL}	Clamping voltage							
I _{RM}	Leakage current @ V _{RM}							
I _{PP}	Peak pulse current							
C	Capacitance							
R _d	Dynamic resistance							
Types	V _{BR} @ I _R			I _{RM} @ V _{RM}		R _d	αT	C
	min.	max.		max.		typ. ⁽¹⁾	max. ⁽²⁾	typ. 0 V bias
	V	V	mA	μA	V	Ω	10 ⁻⁴ /C	pF
ESDA6V1SC5	14.2	18	1	1 0.1	12 3	3.2	10	15

1. Square pulse, I_{pp} = 3 A, tp = 2.5 μs.

2. ΔV_{BR} = αT * (T_{amb} - 25 °C) * V_{BR} (25 °C)

Figure 3. Clamping voltage versus peak pulse current (T_j initial = 25 °C) (Rectangular waveform, $t_p = 2.5 \mu s$)

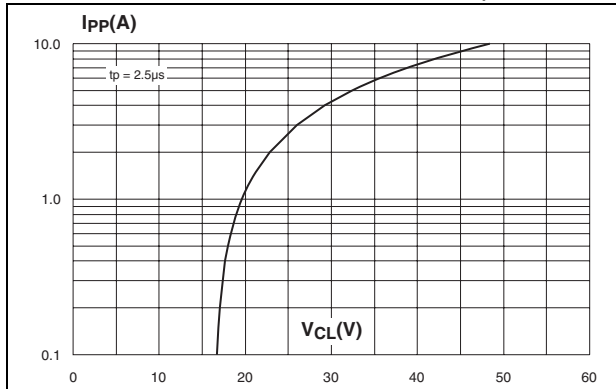

Figure 4. Capacitance versus reverse applied voltage (typical values)

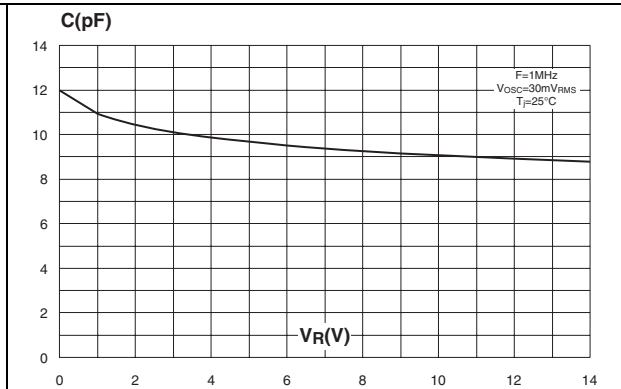

Figure 5. Relative variation of leakage current versus junction temperature (typical values)

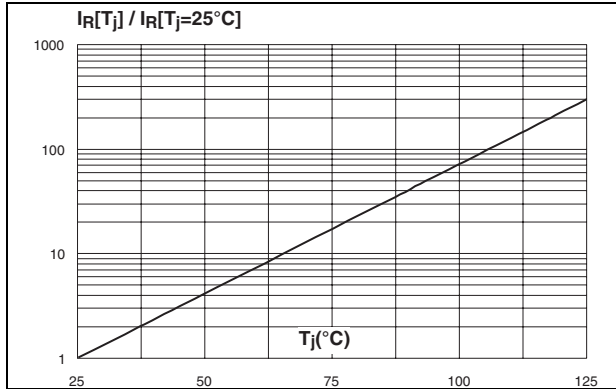

Figure 6. ESD response to IEC 61000-4-2 (+15 kV air discharge)

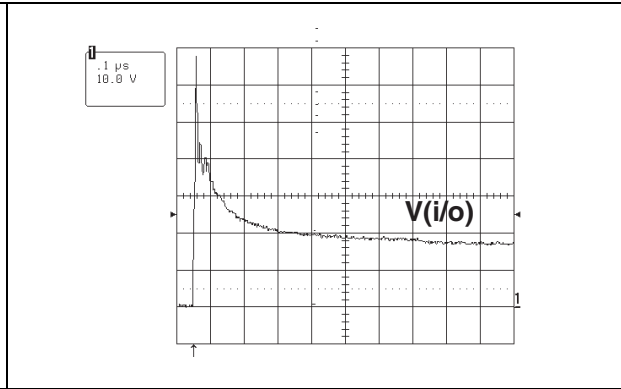

Figure 7. ESD response to IEC 61000-4-2 (-15 kV air discharge)

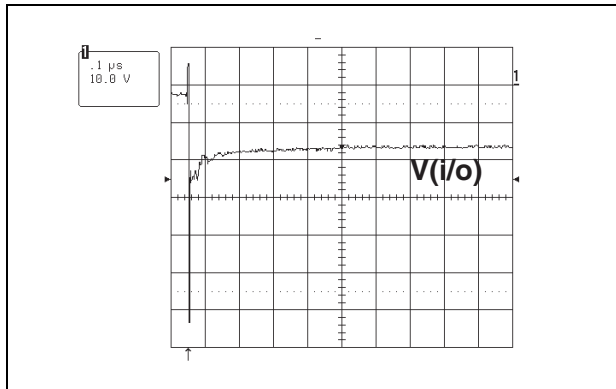

Figure 8. Analog crosstalk

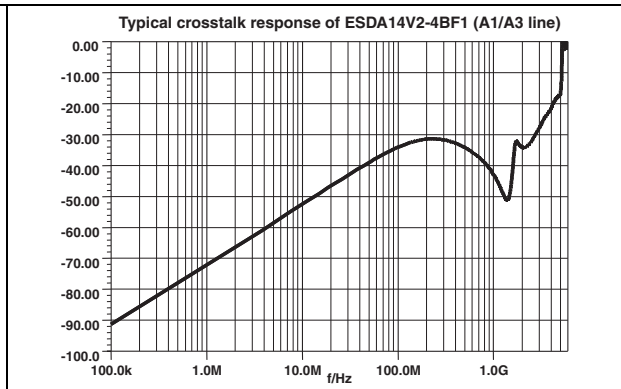
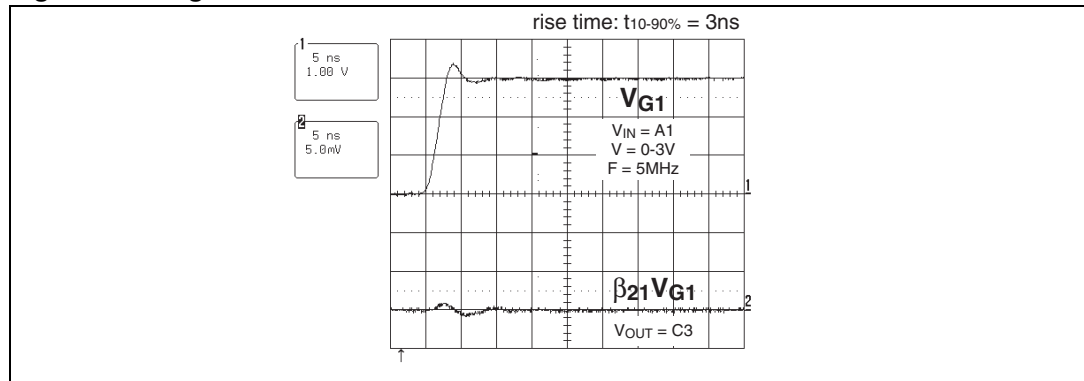

Figure 9. Digital crosstalk



2 Application information

Figure 10. Application example

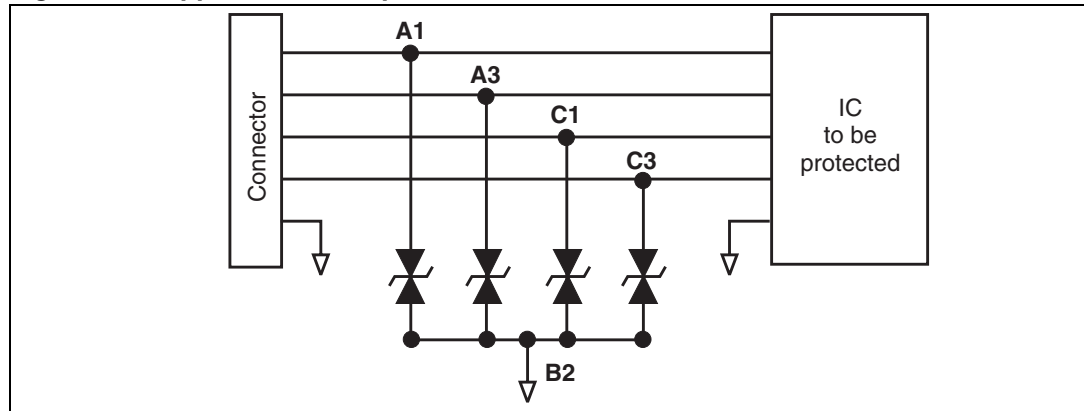
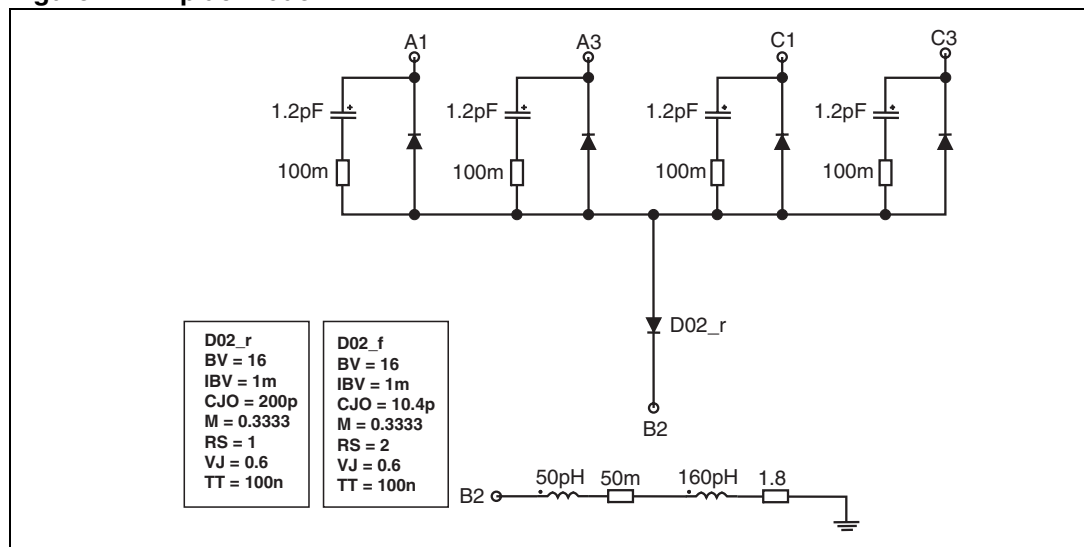
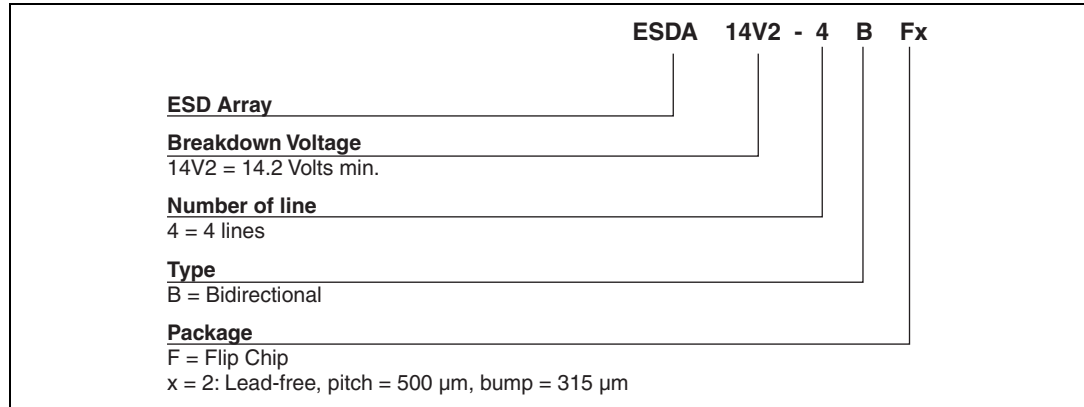

Figure 11. Aplac model



3 Ordering information scheme

Figure 12. Ordering information scheme



4 Package information

In order to meet environmental requirements, ST offers these devices in ECOPACK® packages. These packages have a lead-free second level interconnect. The category of second level interconnect is marked on the inner box label, in compliance with JEDEC Standard JESD97. The maximum ratings related to soldering conditions are also marked on the inner box label. ECOPACK is an ST trademark. ECOPACK specifications are available at www.st.com.

Figure 13. Flip Chip package mechanical data

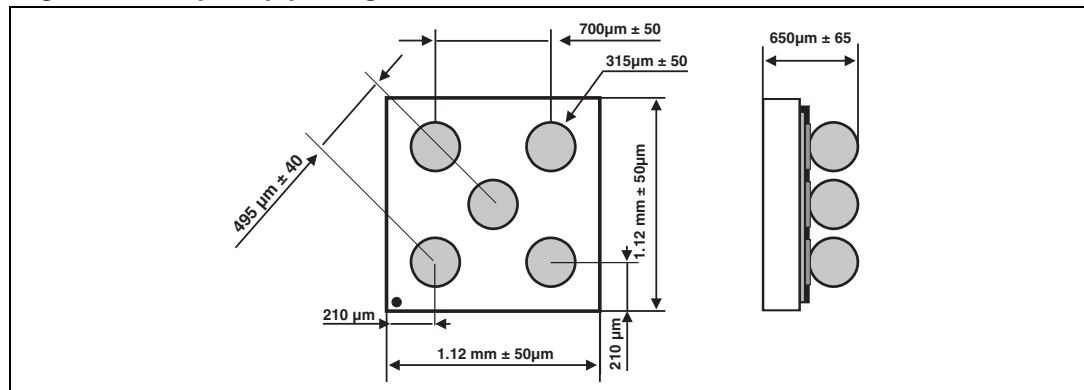

Figure 14. Foot print recommendations Figure 15. Marking

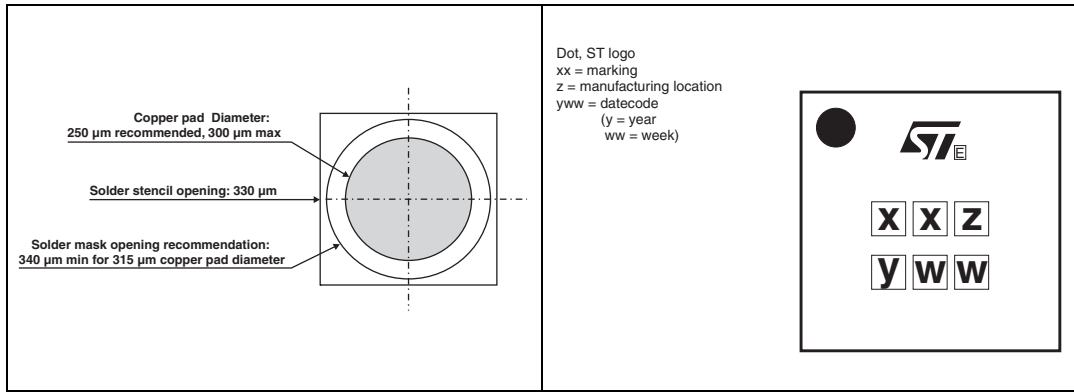
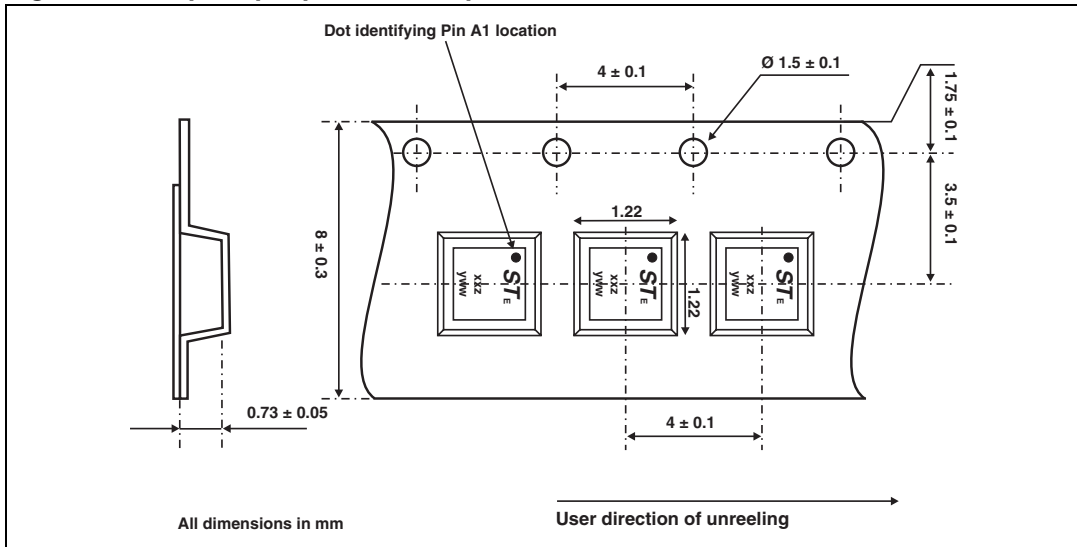

Figure 16. Flip Chip tape and reel specification



5 Ordering information

Table 3. Ordering information

Order code	Marking	Package	Weight	Base qty	Delivery mode
ESDA14V2-4BF2	EA	Flip Chip	2.1 mg	5000	Tape and reel 7"

Note:

More information is available in the application notes:

AN1235: "Flip Chip: Package description and recommendations for use"

AN1751: "EMI filters: Recommendations and measurements"

6 Revision history

Table 4. Document revision history

Date	Revision	Description of changes
14-Mar-2005	1	First issue.
18-Oct-2005	2	Dimension from center bump to corner bump changed in Figure 16 . to indicate diagonal instead of perpendicular measurement. No values changed. ECOPACK statement added.
04-Jun-2007	3	Reformatted to current standard.
16-Apr-2008	4	Updated ECOPACK statement. Updated Figure 12 , Figure 13 and Figure 16 . Reformatted to current standards.

Please Read Carefully:

Information in this document is provided solely in connection with ST products. STMicroelectronics NV and its subsidiaries ("ST") reserve the right to make changes, corrections, modifications or improvements, to this document, and the products and services described herein at any time, without notice.

All ST products are sold pursuant to ST's terms and conditions of sale.

Purchasers are solely responsible for the choice, selection and use of the ST products and services described herein, and ST assumes no liability whatsoever relating to the choice, selection or use of the ST products and services described herein.

No license, express or implied, by estoppel or otherwise, to any intellectual property rights is granted under this document. If any part of this document refers to any third party products or services it shall not be deemed a license grant by ST for the use of such third party products or services, or any intellectual property contained therein or considered as a warranty covering the use in any manner whatsoever of such third party products or services or any intellectual property contained therein.

UNLESS OTHERWISE SET FORTH IN ST'S TERMS AND CONDITIONS OF SALE ST DISCLAIMS ANY EXPRESS OR IMPLIED WARRANTY WITH RESPECT TO THE USE AND/OR SALE OF ST PRODUCTS INCLUDING WITHOUT LIMITATION IMPLIED WARRANTIES OF MERCHANTABILITY, FITNESS FOR A PARTICULAR PURPOSE (AND THEIR EQUIVALENTS UNDER THE LAWS OF ANY JURISDICTION), OR INFRINGEMENT OF ANY PATENT, COPYRIGHT OR OTHER INTELLECTUAL PROPERTY RIGHT.

UNLESS EXPRESSLY APPROVED IN WRITING BY AN AUTHORIZED ST REPRESENTATIVE, ST PRODUCTS ARE NOT RECOMMENDED, AUTHORIZED OR WARRANTED FOR USE IN MILITARY, AIR CRAFT, SPACE, LIFE SAVING, OR LIFE SUSTAINING APPLICATIONS, NOR IN PRODUCTS OR SYSTEMS WHERE FAILURE OR MALFUNCTION MAY RESULT IN PERSONAL INJURY, DEATH, OR SEVERE PROPERTY OR ENVIRONMENTAL DAMAGE. ST PRODUCTS WHICH ARE NOT SPECIFIED AS "AUTOMOTIVE GRADE" MAY ONLY BE USED IN AUTOMOTIVE APPLICATIONS AT USER'S OWN RISK.

Resale of ST products with provisions different from the statements and/or technical features set forth in this document shall immediately void any warranty granted by ST for the ST product or service described herein and shall not create or extend in any manner whatsoever, any liability of ST.

ST and the ST logo are trademarks or registered trademarks of ST in various countries.

Information in this document supersedes and replaces all information previously supplied.

The ST logo is a registered trademark of STMicroelectronics. All other names are the property of their respective owners.

© 2008 STMicroelectronics - All rights reserved

STMicroelectronics group of companies

Australia - Belgium - Brazil - Canada - China - Czech Republic - Finland - France - Germany - Hong Kong - India - Israel - Italy - Japan - Malaysia - Malta - Morocco - Singapore - Spain - Sweden - Switzerland - United Kingdom - United States of America

www.st.com

Looking for pricing, stock, or lifecycle information?

Click below to explore more details on WIN SOURCE:

- ⊖ [View ESDA14V2-4BF2](#) on WIN SOURCE
- ⊖ [STMicroelectronics](#) Information

Optimize Your Supply Chain with WIN SOURCE Solutions

- ✓ Global Sourcing Solution
- ✓ Obsolete Management
- ✓ Cost Control Management
- ✓ Shortage Management
- ✓ Alternative Solution
- ✓ Excess Inventory Management