



**THE DATASHEET OF**  
**10005639-11107LF**



A

B

C

D

PRODUCT NO.  
10005639-XXXX

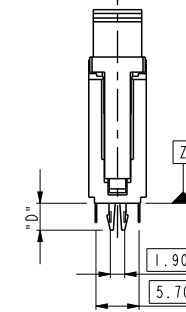
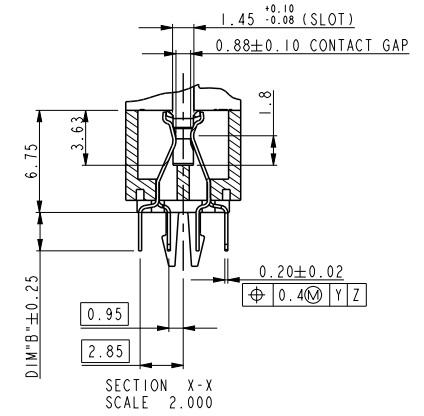
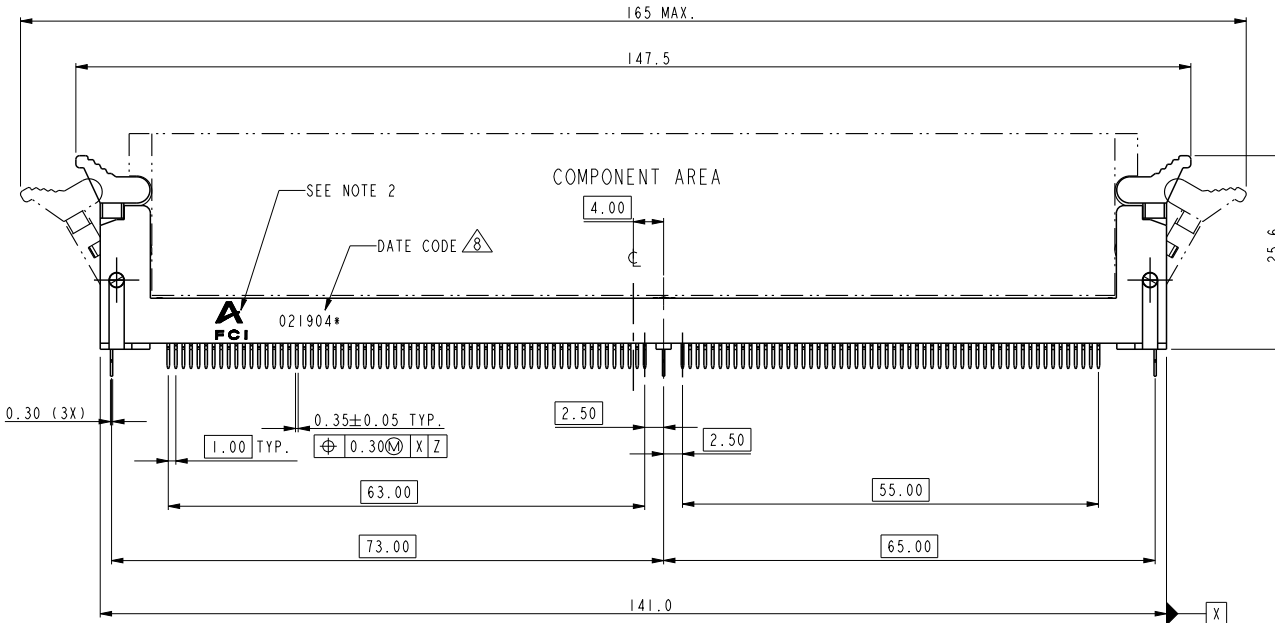
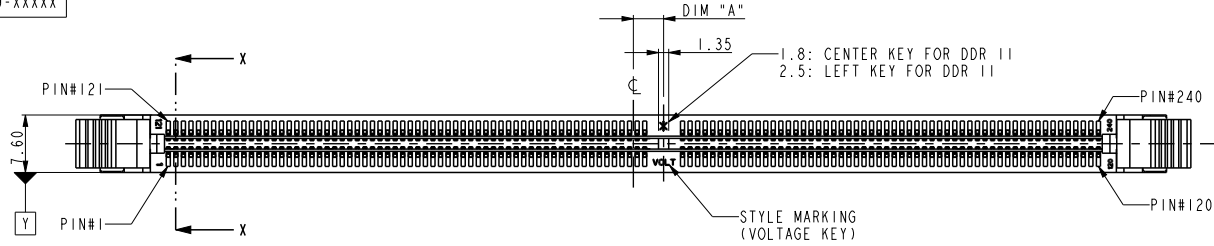

PART NO.	DIM "A"	DESCRIPTION
10005639-1****	4.00	1.8V
10005639-2****	3.00	2.5V
10005639-3****	5.00	X.XV

spec ref	*	dr	Rick Bian	2010/07/08	projection	mm	size	A4	scale	0.500		
tolerance std	TOLERANCES UNLESS OTHERWISE SPECIFIED	eng	Jeny Ren	2018/01/26			ecn no	ELX-DG-28708-1				
ISO 406		chr	-	-				rel level	Released			
ISO 1101		appr	Nickor Zuo	2018/01/29	product family		rev	10005639				
surface	linear	Amphenol FCI www.fci.com			title DDR II 240P V/T DDR II 240P METAL CLIP ASS'Y cat. no.		dwg no		Product - Customer Drw		rev Y	
	0.X											±0.38
	0.XX											±0.25
	0.XXX	±0.13	sheet 1 of 4									
ISO 1302	angular	0°	±2°									

TYPE "R"	X.X VOLTAGE
TYPE "L"	2.5 VOLTAGE
TYPE "C"	1.8 VOLTAGE
SUB KEY POS #1	DESCRIPTION

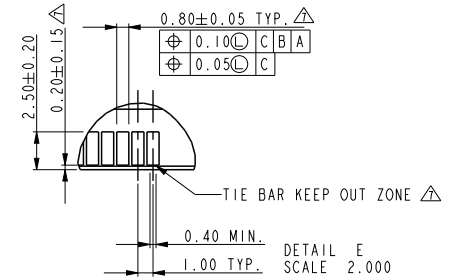
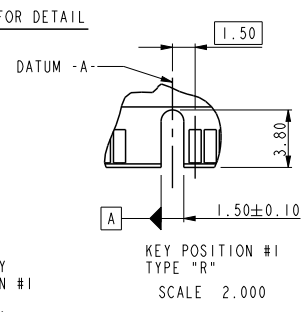
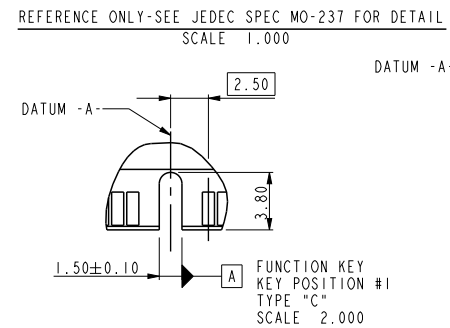
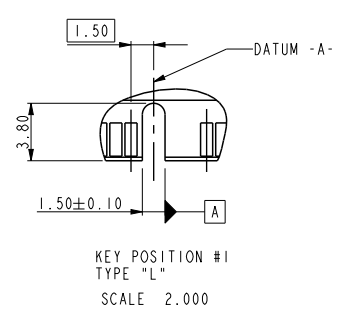
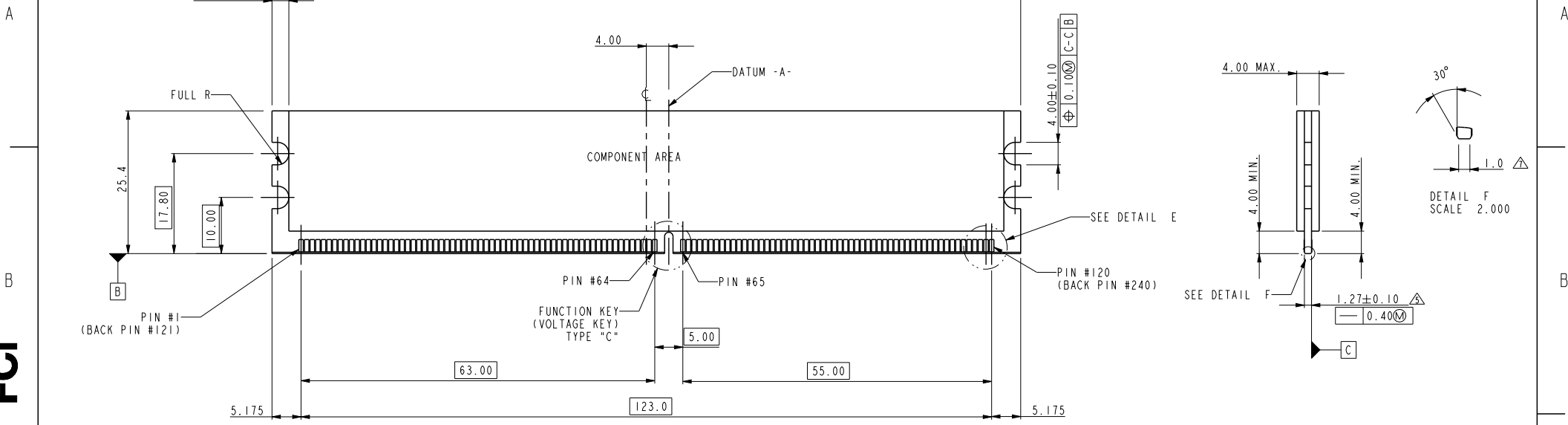

spec ref	*	dr	Rick Bian	2010/07/08	projection	mm	size	A4	scale	0.500										
tolerance std	ISO 406 ISO 1101	eng	Jeny Ren	2018/01/26			ecn no	ELX-DG-28708-1												
surface	<table border="1"> <tr> <td>linear</td> <td>0.X</td> <td>±0.38</td> </tr> <tr> <td></td> <td>0.XX</td> <td>±0.25</td> </tr> <tr> <td></td> <td>0.XXX</td> <td>±0.13</td> </tr> <tr> <td>angular</td> <td>0°</td> <td>±2°</td> </tr> </table>	linear	0.X	±0.38				0.XX	±0.25		0.XXX	±0.13	angular	0°	±2°	chr	-	product family	rel level	Released
linear	0.X	±0.38																		
	0.XX	±0.25																		
	0.XXX	±0.13																		
angular	0°	±2°																		
	ISO 1302	appr	Nickor Zuo	2018/01/29	product family		rev	Y												
		Amphenol FCI	www.fci.com	cat. no.	*	Product - Customer Drw	10005639	sheet 2 of 4												

Creo Title REV E - 2016-02-12

A

B

C

D

A

B

C

D

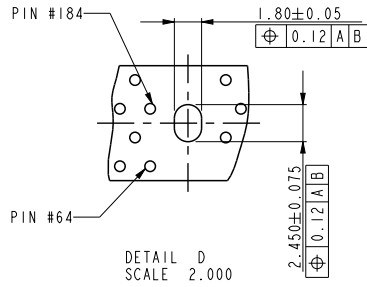
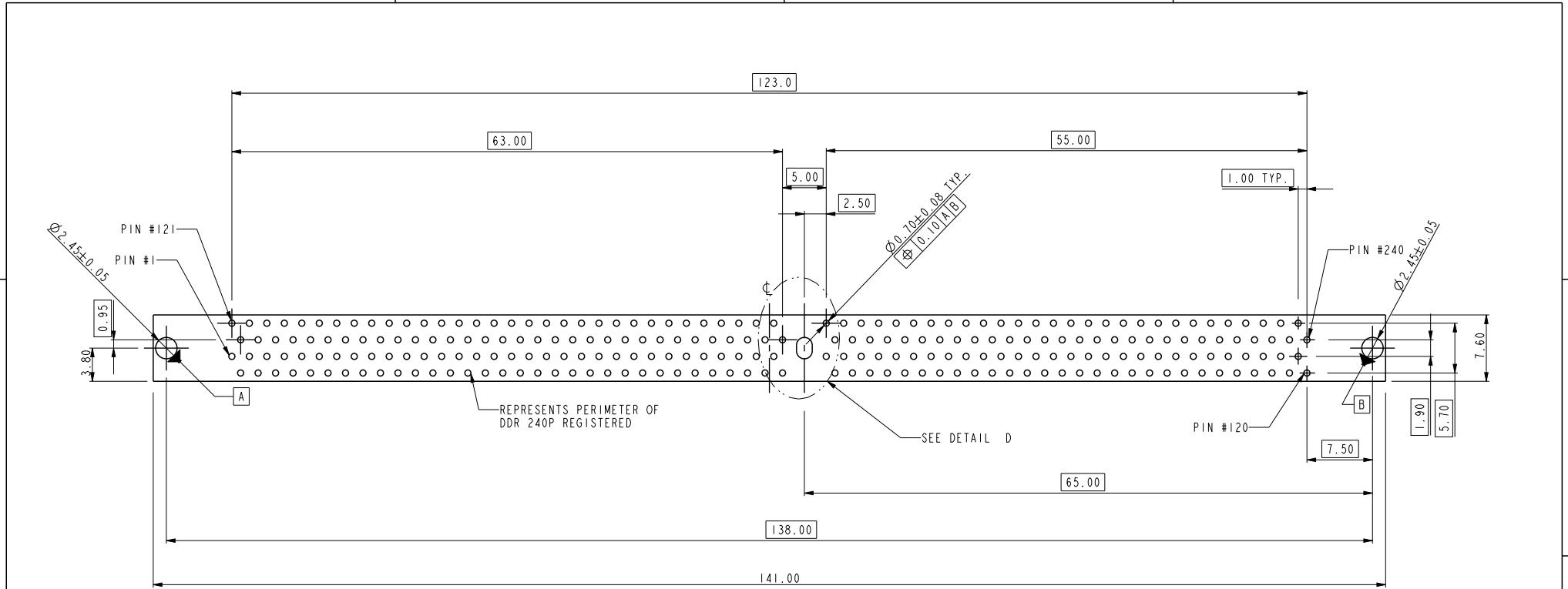

RECOMMENDED CIRCUIT BOARD HOLE LAYOUT

spec ref	*	dr	Rick Bian	2010/07/08	projection 	mm 	size	A4	scale	0.500	
tolerance std	TOLERANCES UNLESS OTHERWISE SPECIFIED	eng	Jeny Ren	2018/01/26			ecn no	ELX-DG-28708-1			
ISO 406 ISO 1101		chr	-	-			rel level	Released			
surface	 linear 0.X ±0.38 0.XX ±0.25 0.XXX ±0.13 angular 0° ±2°	appr	Nickor Zuo	2018/01/29	product family		rev				
ISO 1302		www.fci.com	title		DDR11 240P V/T DDR11 240P METAL CLIP ASS'Y		dwg no		10005639		
		cat. no.		*	Product - Customer Drw			sheet 3 of 4			

10005639 - □ □ □ □ □

STYLE : MECHANICAL KEYING

- 1 : 1.8 VOLT. W/ CENTER KEY#1
- 2 : 2.5 VOLT. W/ LEFT KEY#1
- 3 : X.X VOLT. W/ RIGHT KEY#1

METAL CLIP

- 1 : WITH METAL CLIP + DIM "D"=3.05
- 2 : WITH METAL CLIP + DIM "D"=3.56
- 3 : WITH METAL CLIP + DIM "D"=3.43

TAIL LENGTH

CODE	DIM "B"
0	2.54
1	2.67
2	3.18
3	4.00

PLATING

CODE	CONTACT	SOLDERTAIL	UNDERPLATE
1	10u" (0.25um) MIN. GOLD	100u" (2.54um) MIN. TIN/LEAD	50u" (1.27um) MIN. NICKEL OVERALL
2	15u" (0.38um) MIN. GOLD		
3	30u" (0.76um) MIN. GOLD		
4	3u" (0.076um) MIN. GOLD	100u" (2.54um) MIN. 100% TIN	50u" (1.27um) MIN. NICKEL OVERALL
6LF	10u" (0.25um) MIN. GOLD		
7LF	15u" (0.38um) MIN. GOLD		
8LF	30u" (0.76um) MIN. GOLD	GOLD FLASH	
9LF	3u" (0.076um) MIN. GOLD		
8HLF	30u" (0.76um) MIN. GOLD		

COLOR OF HOUSING AND EJECTOR

- 0 : BLACK HOUSING + IVORY EJECTOR
- 1 : BLUE HOUSING + IVORY EJECTOR
- 2 : BLACK HOUSING + BLACK EJECTOR
- 3 : PURPLE HOUSING + IVORY EJECTOR
- 4 : ORANGE HOUSING + IVORY EJECTOR
- 5 : GREEN HOUSING + IVORY EJECTOR
- 6 : RED HOUSING + IVORY EJECTOR
- 7 : IVORY HOUSING + IVORY EJECTOR
- 8 : YELLOW HOUSING + IVORY EJECTOR
- 9 : IVORY HOUSING + BLACK EJECTOR

NOTES:

1. MATERIAL:
  - HOUSING: HIGH PERFORMANCE RESINS, GLASS FILLED UL94V-0 RATED.
  - EJECTOR: HIGH PERFORMANCE RESINS, GLASS FILLED UL94V-0 RATED.
  - TERMINAL: PHOSPHOR BRONZE.
  - METAL CLIP: COPPER ALLOY.
2. FCI LOGO TO BE APPROXIMATELY LOCATED AS SHOWN ON PRINT.
3. PRODUCT SPECIFICATION: GS-12-251.
4. PACKAGING SPECIFICATION: GS-14-899.
5. CARD THICKNESS APPLIES ACROSS TABS AND INCLUDES PLATING AND/OR METALIZATION.
6. 3.00 mm MINIMUM APPLIES TO BOTH 4.00 mm WIDE NOTCH LENGTH AND COMPONENT KEEP-OUT AREA.
7. LEADING EDGE OF CONTACT PADS SPECIFIED BY THE KEEP OUT ZONE SHALL BE FREE OF BURRS AND EXTERNAL TIE BARS. FOR OPTIMUM PERFORMANCE, THE TIE BAR IS TO BE ON AN INTERNAL LAYER SO THAT THE REMNANT CANNOT CAUSE CONTACT DAMAGE.
8. THE DATE CODE IS SHOWN "MM-DD-YY\*" "\*" MEANS PRODUCTION LINE CODE.
9. THIS PRODUCT MEETS EUROPEAN UNION DIRECTIVES AND OTHER COUNTRY REGULATIONS AS DESCRIBED IN GS-22-008.
10. THE HOUSING WILL WITH STAND EXPOSURE TO 260°C PEAK TEMPERATURE FOR 10 SECONDS IN A WAVE SOLDER APPLICATION.

spec ref *		dr <b>Rick Bian</b>		2010/07/08		projection		size A4		scale 0.500	
tolerance std		eng <b>Jeny Ren</b>		2018/01/26						ecn no <b>ELX-DG-28708-1</b>	
ISO 406 ISO 1101		chr -		-						rel level <b>Released</b>	
surface		appr <b>Nickor Zuo</b>		2018/01/29		product family		rev		10005639	
linear <ul style="list-style-type: none"> <li>0.X ±0.38</li> <li>0.XX ±0.25</li> <li>0.XXX ±0.13</li> </ul> angular 0° ±2°				title DDRII 240P V/T DDRII 240P METAL CLIP ASS'Y		dwg no		Y			
ISO 1302		www.fci.com		cat. no. *		Product - Customer Drw		sheet 4 of 4			

## Looking for pricing, stock, or lifecycle information?

Click below to explore more details on WIN SOURCE:

 [View 10005639-11107LF on WIN SOURCE](#)

 [Amphenol Information](#)

## Optimize Your Supply Chain with WIN SOURCE Solutions

-  Global Sourcing Solution
-  Obsolete Management
-  Cost Control Management
-  Shortage Management
-  Alternative Solution
-  Excess Inventory Management