



**THE DATASHEET OF  
119987-E**



# iBridge Ultra

2 mm Cable-to-Board Connectors

---

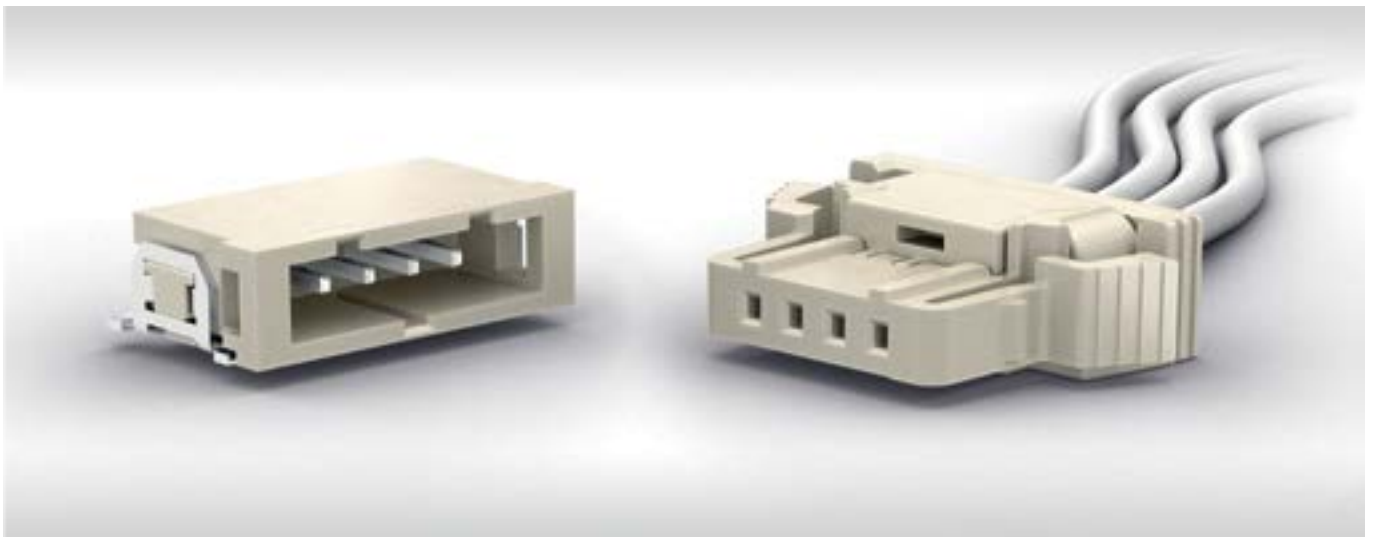

# IBRIDGE ULTRA - CABLE-TO-BOARD CONNECTORS

The iBridge Ultra connector family offers extensive Cable-to-Board solutions. It is designed for applications which need reliable and robust connection systems. A Terminal Position Assurance (TPA) retainer serves as a secondary lock for the female contact in the housing. The secondary lock makes the connections particularly resistant against strong vibrations, such as those that occur in an automotive application. The iBridge Ultra connector is not limited to automotive and is a great choice for applications in industrial automation, telecommunications and healthcare.

The iBridge Ultra connector's compact design supports a wide range of applications between control units and local components such as sensors, motors, switches, fans, heating elements, fuses or LEDs.

- current rating up to 8 A per contact
- compact due to a pitch of 2 mm
- different numbers of pins available
- crimp contacts for American Wire Gauge (AWG) 22 and AWG 24
- secondary locking of the crimp contacts in the housing (TPA)
- polarity reversal protection design
- double-sided interlocking
- specifications are tested according to requirements of USCAR-2 and USCAR-21



## FEATURES

Pitch	2 mm
No. of Pins	2, 3, 4, 5, 6, 8, 10, 12 possible
Current rating per contact	up to 8 A (depends on cable)
Termination technology	male connector with Surface Mount Technology (SMT) or DIP solder termination female connector with crimp termination
Cables	discrete wire AWG 22 and AWG 24
Variants	vertical male connector right angle male connector female connector with 180° cable outlet



## FEATURES

### Double Locking System

- Includes TPA (a retainer) feature which serves as a secondary lock to increase reliability by safe-guarding against accidental wire pulling and limits female contact movement in housing cavity, ultimately enhancing performance in high vibration and mechanical shock environments



### Polarization and Locking Feature

- Polarization feature for more error reduced mating
- Latches on both sides of female connectors help provide positive locking and easy handling

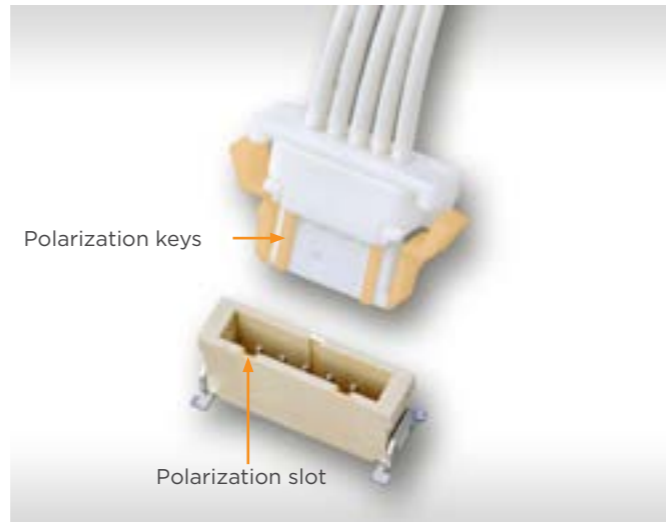

### Close Box and Dual Beam Female Contact

- Close box female contact design make sure male contact in secure position
- Dual contact beam compensates misalignment mating tolerance



## FEATURES

### Stamped Male Contacts

- Stamped contacts without post bending help ensure robustness, coplanarity and current carrying efficiency

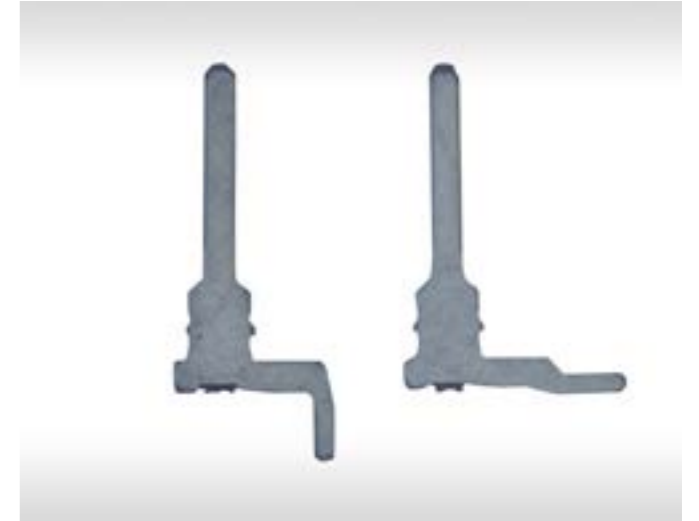

### PCB Retention and Error Proof

- 2 location pegs round and oval - for accurate placement on Printed Circuit Board (PCB)
- Long locating pegs for vertical male - enhance retention force

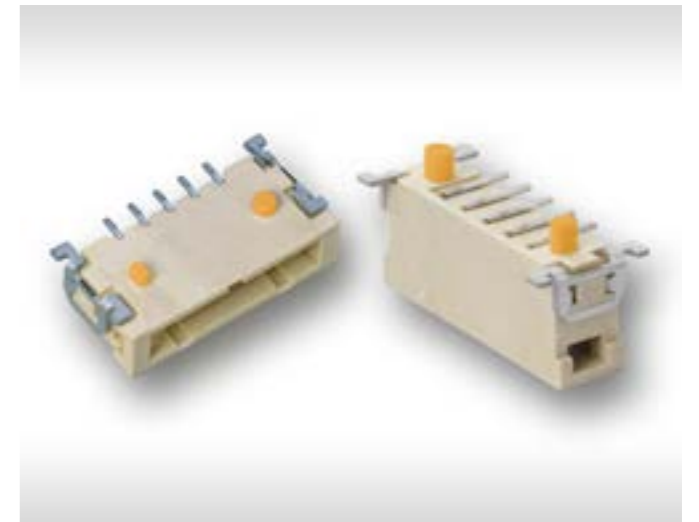

- Metal soldering clip for SMT - helps provide PCB retention and strain relief for contacts

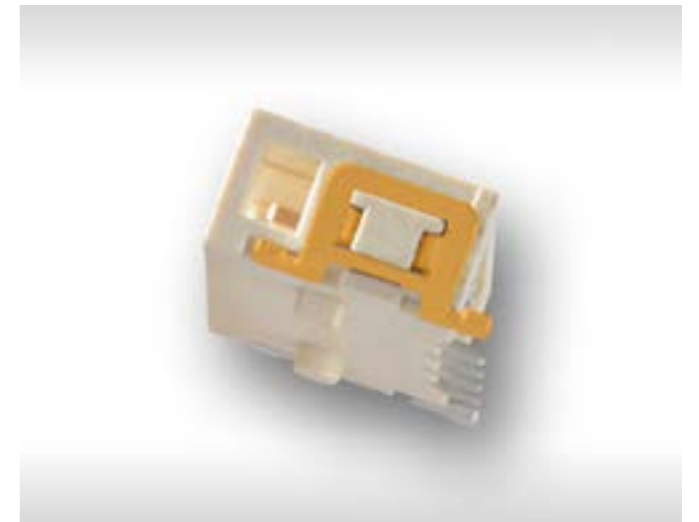

# ELECTRICAL AND MECHANICAL CHARACTERISTICS

## Technical Data

Description	Standard	Male Connector (DIP, SMT)	Female Connector (Crimp)
Temperature range (USCAR)	USCAR-2	-40 – +100 °C, 1008hrs at 100 °C (USCAR-2 T2)	
Current rating per contact	IEC60512 test 5b	up to 8 A (depends on cable)	
Air and creepage distance		0.7 mm	
Operating voltage	IEC 60664	300 V <sub>rms</sub> (pollution degree 1), 95 V <sub>rms</sub> (pollution degree 2)	
Mechanical operation	IEC 60512 test 9a	> 20 mating cycles	
<b>Process Conditions</b>			
Hand soldering temperature max.	IEC 60068-2-20	3,5 s at 350 °C	
DIP soldering temperature max.	JEDEC J-STD-002	10 s at 260 °C	
Reflow soldering temperature max.	JEDEC J-STD-002	20 - 40 s at 260 °C	
Coplanarity		< 0.1 mm	
<b>Housing Material</b>			
Plastic material		LCP natural	PA natural
Tracking resistance (CTI)	IEC 60112	175 V	600 V
UL flame rating	UL	94 V-0	
<b>Contact Material</b>			
Base material		Cu alloy	
Mating area		Sn	
Termination area		Sn	
<b>Soldering Bracket Material</b>			
Base material		Cu alloy	
Plating		Sn	
<b>Product Approval</b>			
Validation testing		USCAR-2, USCAR-21	
UL		E472031	

# VERTICAL MALE CONNECTOR, SMT

## Product Specification

- SMT termination
- 2, 3, 4, 5, 6, 8, 10, 12 pins possible
- tape and reel packaging for automated assembly process
- for available part numbers please refer to our website



## Dimensional Drawings

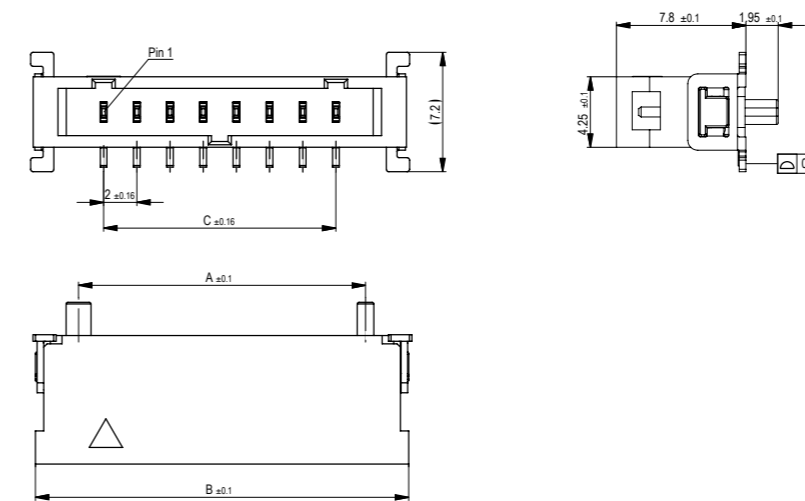

No. of Contacts	A	B	C
2	5.3	10.5	2.0
3	7.3	12.5	4.0
4	9.3	14.5	6.0
5	11.3	16.5	8.0
6	13.3	18.5	10.0
8	17.3	22.5	14.0
10	21.3	26.5	18.0
12	25.3	30.5	22.0

All dimensions in mm

## Recommended Layout

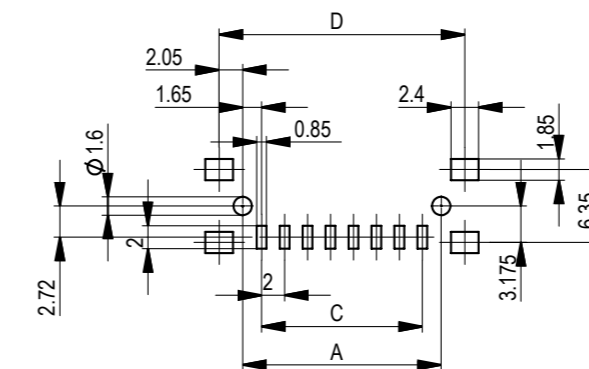

# VERTICAL MALE CONNECTOR, DIP

## Product Specification

- DIP solder termination
- 2, 3, 4, 5, 6, 8, 10, 12 pins possible
- tube packaging
- for available part numbers please refer to our website



## Dimensional Drawings

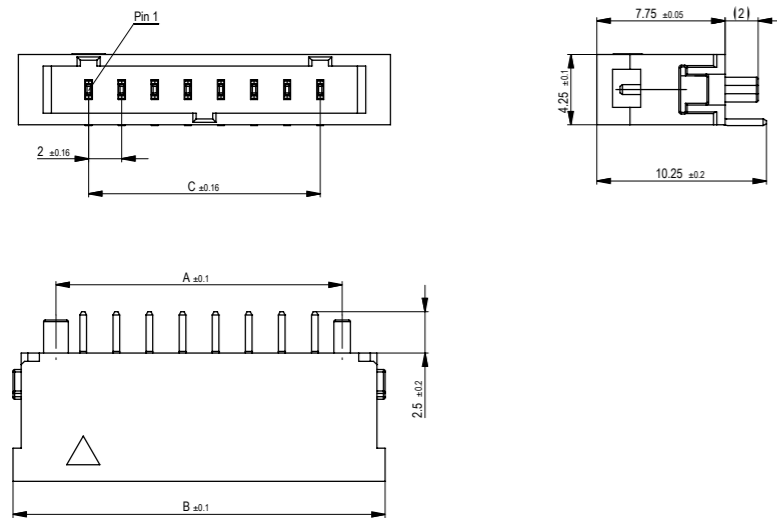

No. of Contacts	A	B	C
2	5.3	10.5	2.0
3	7.3	12.5	4.0
4	9.3	14.5	6.0
5	11.3	16.5	8.0
6	13.3	18.5	10.0
8	17.3	22.5	14.0
10	21.3	26.5	18.0
12	25.3	30.5	22.0

All dimensions in mm

## Recommended Layout

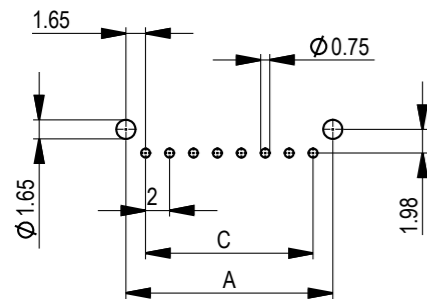

# RIGHT ANGLE MALE CONNECTOR, SMT

## Product Specification

- SMT termination
- 2, 3, 4, 5, 6, 8, 10, 12 pins possible
- tape and reel packaging for automated assembly process
- for available part numbers please refer to our website



## Dimensional Drawings

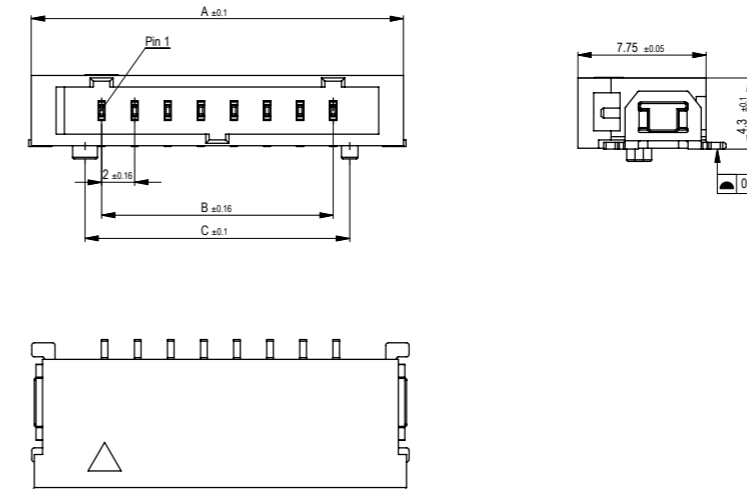

No. of Contacts	A	B	C
2	10.5	2.0	4.0
3	12.5	4.0	6.0
4	14.5	6.0	8.0
5	16.5	8.0	10.0
6	18.5	10.0	12.0
8	22.5	14.0	16.0
10	26.5	18.0	20.0
12	30.5	22.0	24.0

All dimensions in mm

## Recommended Layout

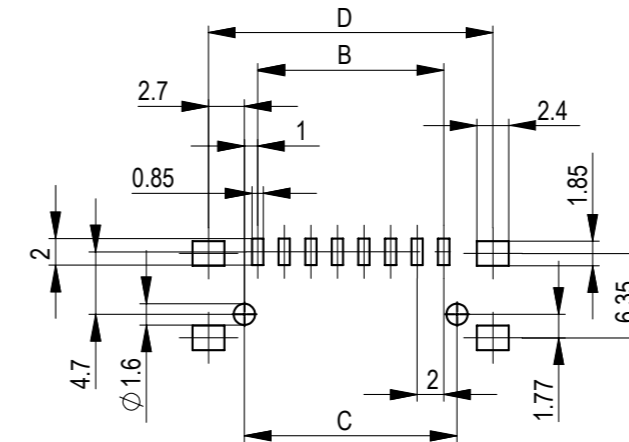

# RIGHT ANGLE MALE CONNECTORS, DIP

## Product Specification

- DIP solder termination
- 2, 3, 4, 5, 6, 8, 10, 12 pins possible
- tube packaging
- for available part numbers please refer to our website



## Dimensional Drawings

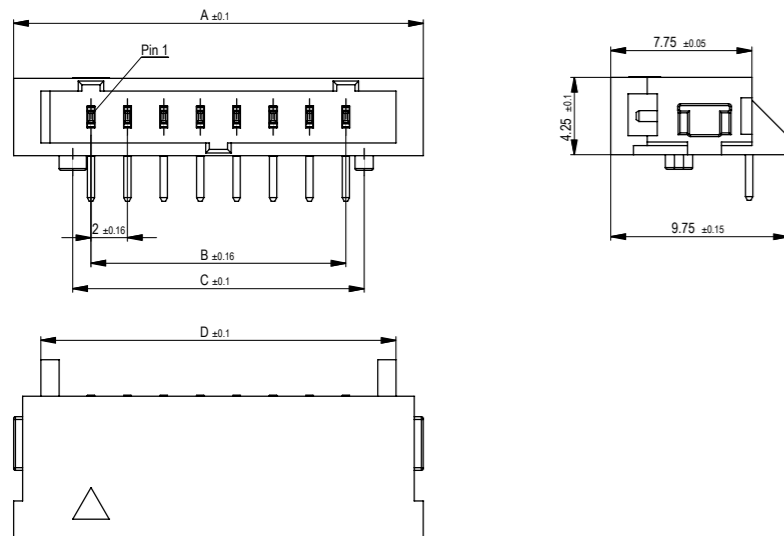

No. of Contacts	A	B	C	D
2	10.5	2.0	4.0	7.5
3	12.5	4.0	6.0	9.5
4	14.5	6.0	8.0	11.5
5	16.5	8.0	10.0	13.5
6	18.5	10.0	12.0	15.5
8	22.5	14.0	16.0	19.5
10	26.5	18.0	20.0	23.5
12	30.5	22.0	24.0	27.5

All dimensions in mm

## Recommended Layout

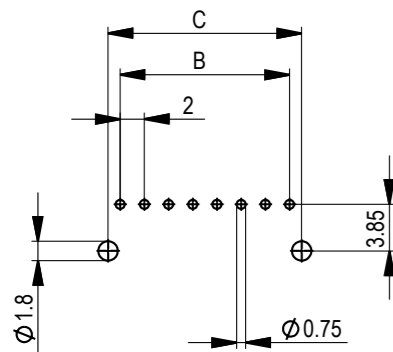

# FEMALE CABLE CONNECTOR

## Product Specification

- cable connector housing and retainer
- 2, 3, 4, 5, 6, 8, 10, 12 pins possible
- 180° cable outlet
- for female crimp contacts
- AWG 22 and AWG 24
- for available part numbers please refer to our website



## Dimensional Drawings

Cable Connector Housing

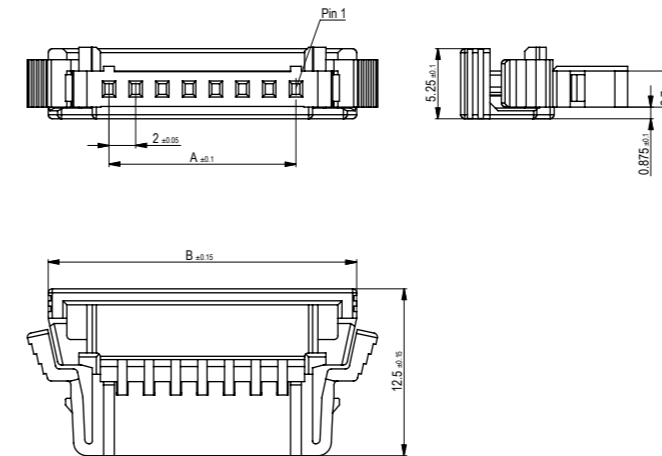

No. of Contacts	A	B
2	2.0	11.1
3	4.0	13.1
4	6.0	15.1
5	8.0	17.1
6	10.0	19.1
8	14.0	23.1
10	18.0	27.1
12	22.0	31.1

All dimensions in mm

Retainer

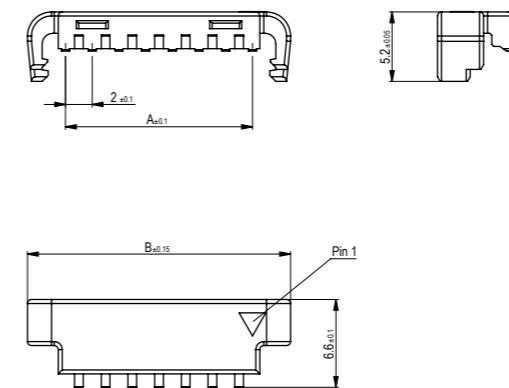

No. of Contacts	A	B
2	2.0	7.7
3	4.0	9.7
4	6.0	11.7
5	8.0	13.7
6	10.0	15.7
8	14.0	19.7
10	18.0	23.7
12	22.0	27.7

All dimensions in mm

# FEMALE CRIMP CONTACT

## Product Specification

- female crimp contact
- AWG 22 and AWG 24
- Reel packaging
- for available part numbers please refer to our website



## Ordering Information

Contacts	Cable Type	Termination	Packaging
Female Contact	AWG 22, 24	Crimp	Reel / 10000 pcs

# CABLE ASSEMBLIES

## Product Specification

- standard cable assemblies
- 2, 3, 4, 5, 6, 8, 10, 12 pins possible
- 180° cable outlet
- female connectors
- cable length 100 mm (200 mm and 300 mm on request)
- AWG 22 and AWG 24
- single- and dual-ended
- for available part numbers please refer to our website

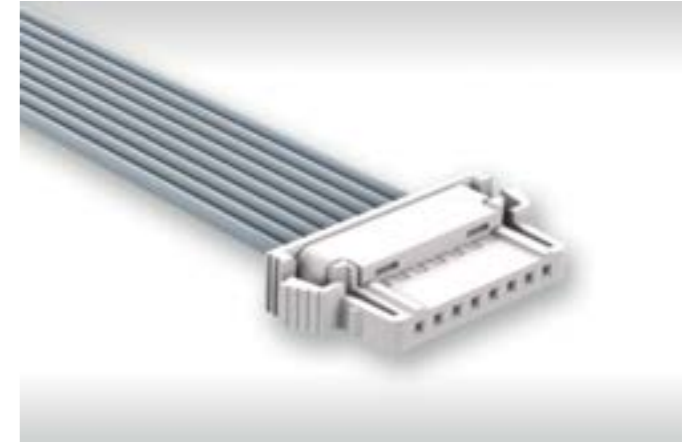

## Dimensional Drawings

Single-Ended

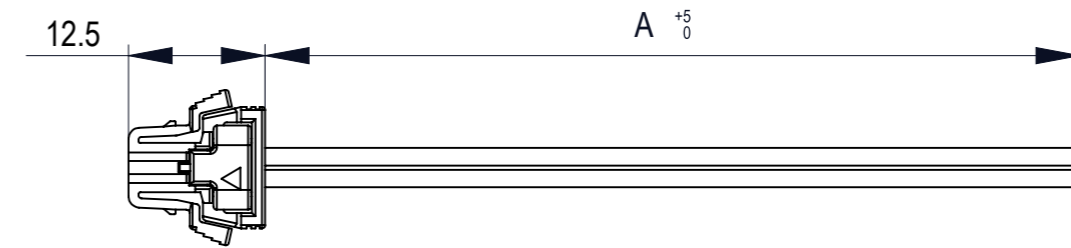

Dual-Ended

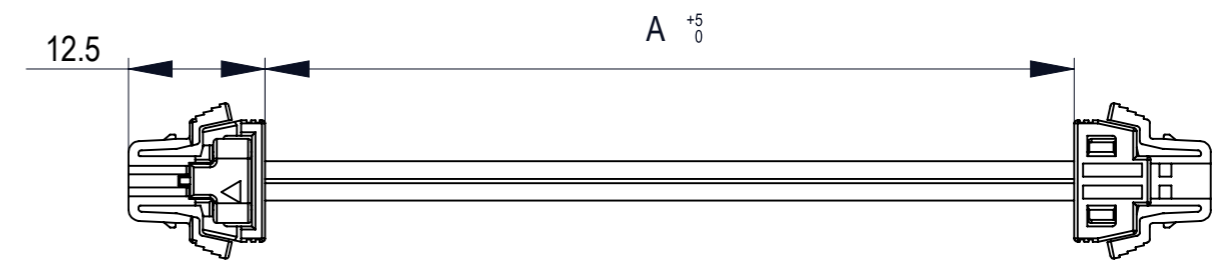

All dimensions in mm

---

## Connect With Us

We make it easy to connect with our experts and are ready to provide the support you need. Visit [www.te.com/support](http://www.te.com/support) to chat with a Product Information Specialist.

---

### te.com

2022 TE Connectivity. All Rights Reserved.

TE Connectivity, TE connectivity (logo) ERNI, iBridge Ultra and Every Connection Counts are trademarks owned or licensed by the TE Connectivity family of companies. All other logos, products and/or company names referred to herein might be trademarks of their respective owners.

The information given herein, including drawings, illustrations and schematics which are intended for illustration purposes only, is believed to be reliable. However, TE Connectivity makes no warranties as to its accuracy or completeness and disclaims any liability in connection with its use. TE Connectivity's obligations shall only be as set forth in TE Connectivity's Standard Terms and Conditions of Sale for this product and in no case will TE Connectivity be liable for any incidental, indirect or consequential damages arising out of the sale, resale, use or misuse of the product. Users of TE Connectivity products should make their own evaluation to determine the suitability of each such product for the specific application.

074683 03/22 Original

### CATALOG



TE Connectivity

ERNI Electronics GmbH & Co. KG  
a TE Connectivity Ltd. company  
Seestraße 9  
73099 Adelberg  
Germany

Tel +49 7166 50-0  
[www.te.com](http://www.te.com)  
[www.erni.com](http://www.erni.com)

## Looking for pricing, stock, or lifecycle information?

Click below to explore more details on WIN SOURCE:

-  [View 119987-E on WIN SOURCE](#)
-  [TE Connectivity Information](#)

## Optimize Your Supply Chain with WIN SOURCE Solutions

-  Global Sourcing Solution
-  Obsolete Management
-  Cost Control Management
-  Shortage Management
-  Alternative Solution
-  Excess Inventory Management