



**THE DATASHEET OF**  
**11828-2CA**



PART NUMBER

SEE TABLE

REVISIONS

REV.	DESCRIPTION	EC #	DATE	DRAWN
J	ADDED SHEET W/O ALIGNMENT POSTS	N/A	07/05/2022	GQUIGLEY

NOTES:

- 1 MATERIAL  
HOUSING: HIGH TEMPERATURE THERMOPLASTIC  
CONTACT: COPPER ALLOY  
CONTACT PLATING: UNDERPLATE WITH NICKEL,  
HARD GOLD IN MATING AREA  
PURE MATTE TIN ON CONTACT TAIL
- 2. PLEASE REFER TO PRODUCT SPECIFICATION FOR MECHANICAL AND ELECTRICAL SPECIFICATION.
- 3 DATUM B IS DEFINED AS THE PLANE INTERSECTING THE  $\varnothing 0.700\text{mm}$  POST AND PARALLEL TO DATUM D
- 4 DATUM C IS DEFINED AS THE PLANE INTERSECTING THE  $\varnothing 0.700\text{mm}$  POST AND PERPENDICULAR TO DATUM B.
- 5 THIS DIMENSION IS MEASURED (FOR EACH SOLDER LEAD) AS THE DEVIATION FROM A BEST-FIT PLANE CREATED FROM THE SURFACES REFERENCED AT THE ENDS OF THE PART.
- 6 THIS DIMENSION IS MEASURED (FOR EACH SOLDER LEAD) AS THE DEVIATION FROM A BEST-FIT PLANE CREATED FROM ALL THE SOLDER LEADS.
- 7. REGULATIONS  
A. THIS PRODUCT MEETS THE RESTRICTION OF HAZARDOUS SUBSTANCES DIRECTIVE (RoHS) 2011 65 EU.

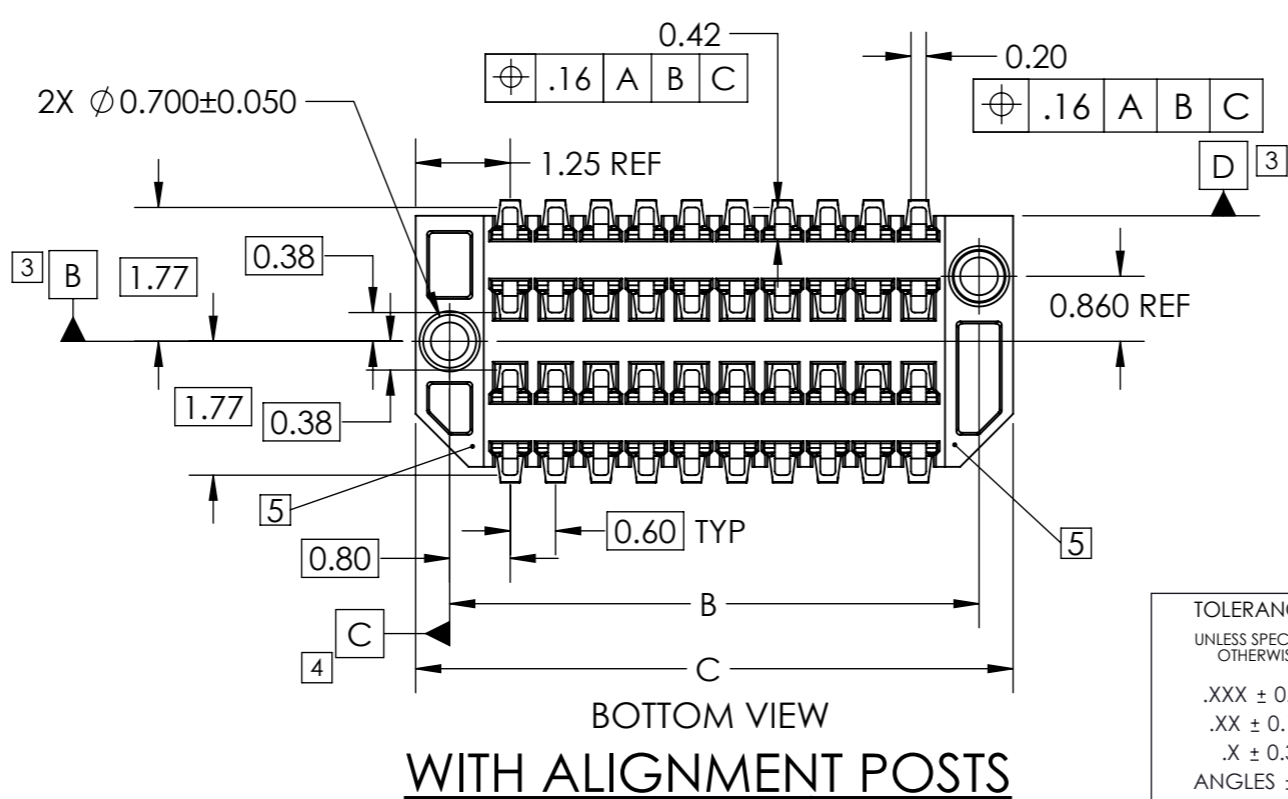
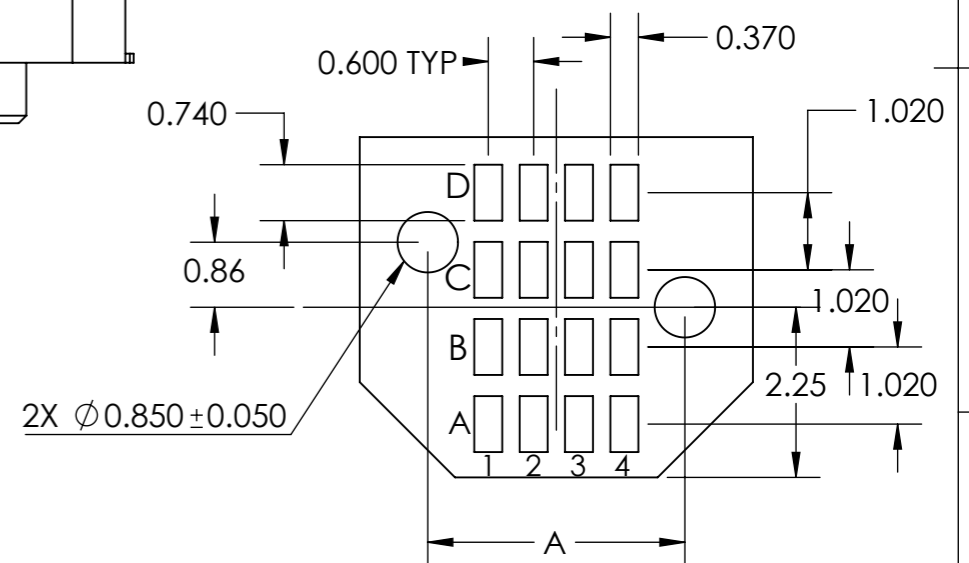
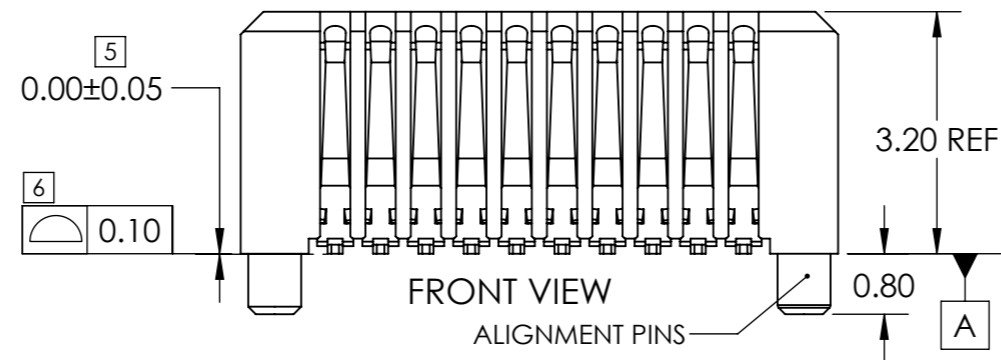
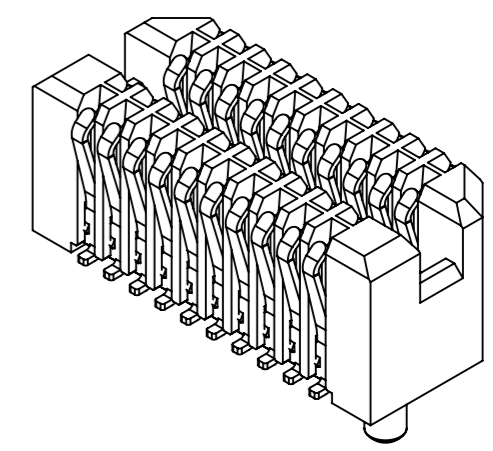
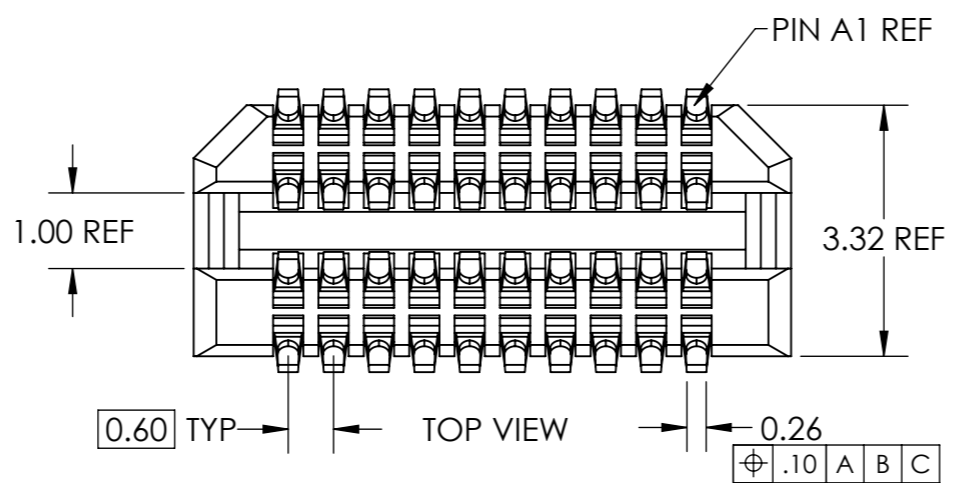

TOLERANCES  
UNLESS SPECIFIED  
OTHERWISE  
.XXX ± 0.05  
.XX ± 0.13  
.X ± 0.3  
ANGLES ± 1°

ALL DIMENSIONS AND TOLERANCES  
PER ASME Y14.5M  
ALL DIMENSIONS ARE IN  
MILLIMETERS UNLESS OTHERWISE  
SPECIFIED

<b>Amphenol</b>		825 OLD TRAIL ROAD ETTERS, PA 17319 717-915-1400	
AMPHENOL INTERCON SYSTEMS INC.		PART <b>LYNX RECEPTACLE ASSEMBLY</b> 0.6mm PITCH	DRAWING <b>11828C</b> CUSTOMER
DRAWN	DATE 10/28/2020	DEPT NO 45	REV J
ENGR/APV	DATE	SCALE 10:1	SHEET 1 OF 5

F  
E  
D  
C  
B  
A

F  
E  
D  
C  
B  
A

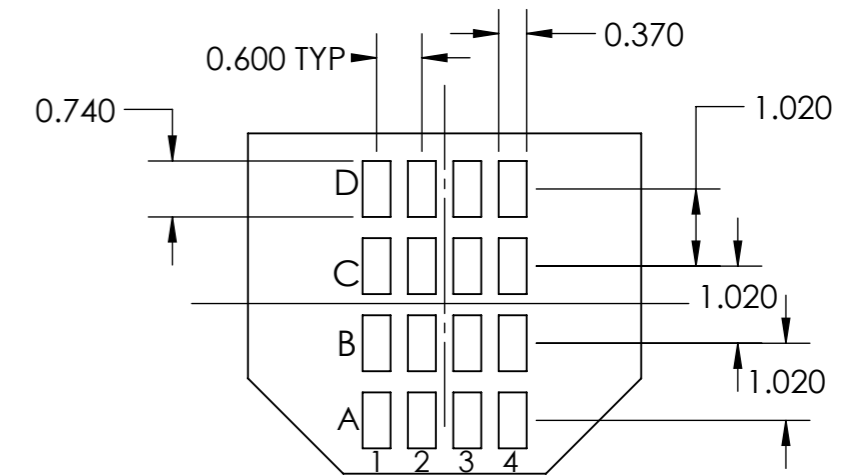
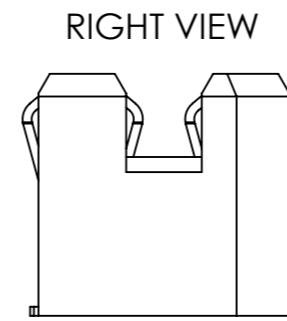
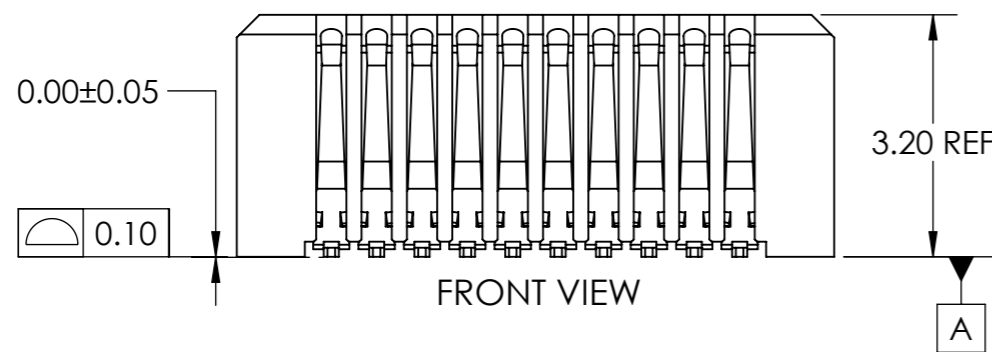
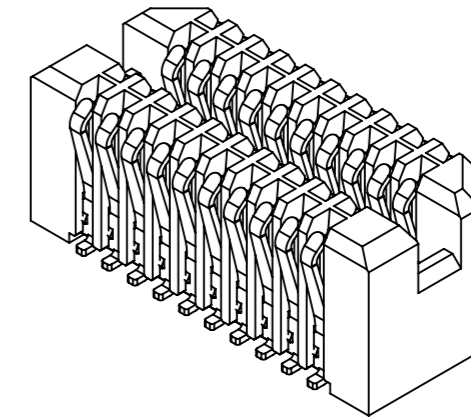
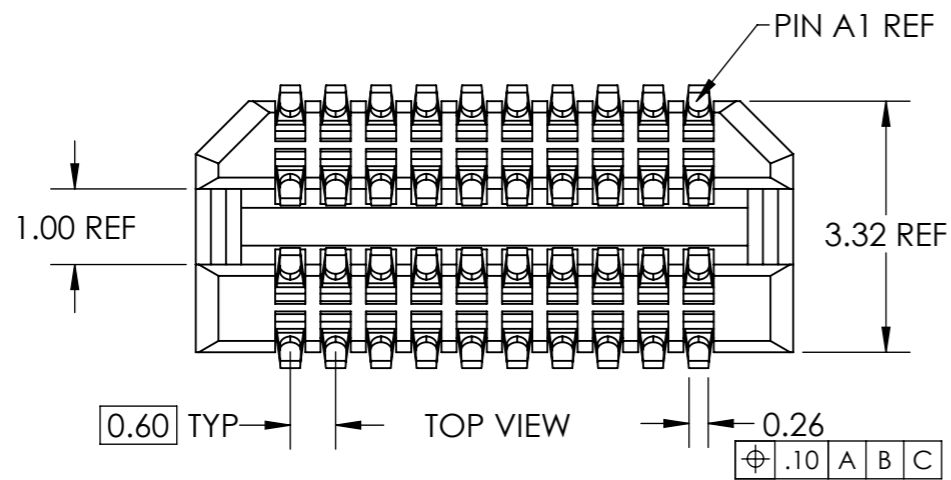

RECOMMENDED PCB PAD LAYOUT  
(PARTIAL VIEW SHOWN FOR CLARITY)

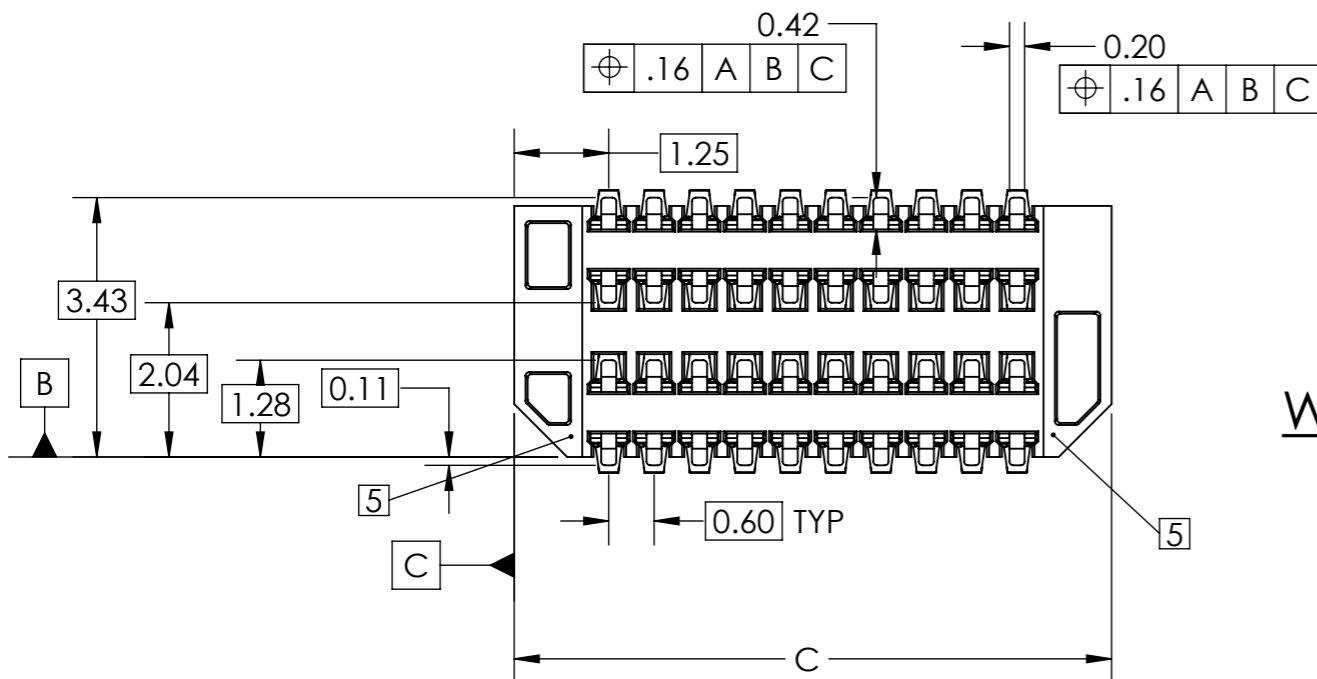

WITHOUT ALIGNMENT POSTS

TOLERANCES  
UNLESS SPECIFIED  
OTHERWISE  
.XXX ± 0.05  
.XX ± 0.13  
.X ± 0.3  
ANGLES ± 1°

ALL DIMENSIONS AND TOLERANCES  
PER ASME Y14.5M  
ALL DIMENSIONS ARE IN  
**MILLIMETERS** UNLESS OTHERWISE  
SPECIFIED

THIRD ANGLE  
PROJECTION

INSPECTION  
◇ FIRST PIECE  
○ IN-PROCESS  
△ SPC

DRAWN		DATE		DEPT NO		REV	
ENGR/APV		10/28/2020		45		J	
SCALE		DATE		SCALE		SHEET	
10:1				10:1		2 OF 5	

**Amphenol** 825 OLD TRAIL ROAD  
ETTERS, PA 17319  
AMPHENOL INTERCON SYSTEMS INC. 717-915-1400

PART  
**LYNX RECEPTACLE ASSEMBLY**  
0.6mm PITCH

DRAWING  
**11828C**  
CUSTOMER

TABLE 1 - WITH ALIGNMENT PINS AND PROTECTIVE CAP					
PART NUMBER	PART DESCRIPTION	NO. OF POSITIONS	DIM B	DIM C	
11828-1AA	RECEPTACLE ASSEMBLY, 10 POSITION, W/ ALIGNMENT PINS & CAP	10	7.00	7.9	
11828-1BA	RECEPTACLE ASSEMBLY, 20 POSITION, W/ ALIGNMENT PINS & CAP	20	13.00	13.9	
11828-1CA	RECEPTACLE ASSEMBLY, 30 POSITION, W/ ALIGNMENT PINS & CAP	30	19.00	19.9	
11828-1DA	RECEPTACLE ASSEMBLY, 40 POSITION, W/ ALIGNMENT PINS & CAP	40	25.00	25.9	
11828-1EA	RECEPTACLE ASSEMBLY, 50 POSITION, W/ ALIGNMENT PINS & CAP	50	31.00	31.9	
11828-1FA	RECEPTACLE ASSEMBLY, 60 POSITION, W/ ALIGNMENT PINS & CAP	60	37.00	37.9	
11828-1GA	RECEPTACLE ASSEMBLY, 70 POSITION, W/ ALIGNMENT PINS & CAP	70	43.00	43.9	
11828-1HA	RECEPTACLE ASSEMBLY, 15 POSITION, W/ ALIGNMENT PINS & CAP	15	10.00	10.9	
11828-1JA	RECEPTACLE ASSEMBLY, 3 POSITION, W/ ALIGNMENT PINS & CAP	3	2.80	3.7	

TABLE 2 - WITHOUT ALIGNMENT PINS AND WITH PROTECTIVE CAP					
PART NUMBER	PART DESCRIPTION	NO. OF POSITIONS	DIM B	DIM C	
11828-1AB	RECEPTACLE ASSEMBLY, 10 POSITION, W/O ALIGNMENT PINS & WITH CAP	10	7.00	7.9	
11828-1BB	RECEPTACLE ASSEMBLY, 20 POSITION, W/O ALIGNMENT PINS & WITH CAP	20	13.00	13.9	
11828-1CB	RECEPTACLE ASSEMBLY, 30 POSITION, W/O ALIGNMENT PINS & WITH CAP	30	19.00	19.9	
11828-1DB	RECEPTACLE ASSEMBLY, 40 POSITION, W/O ALIGNMENT PINS & WITH CAP	40	25.00	25.9	
11828-1EB	RECEPTACLE ASSEMBLY, 50 POSITION, W/O ALIGNMENT PINS & WITH CAP	50	31.00	31.9	
11828-1FB	RECEPTACLE ASSEMBLY, 60 POSITION, W/O ALIGNMENT PINS & WITH CAP	60	37.00	37.9	
11828-1GB	RECEPTACLE ASSEMBLY, 70 POSITION, W/O ALIGNMENT PINS & WITH CAP	70	43.00	43.9	
11828-1HB	RECEPTACLE ASSEMBLY, 15 POSITION, W/O ALIGNMENT PINS & WITH CAP	15	10.00	10.9	
11828-1JB	RECEPTACLE ASSEMBLY, 3 POSITION, W/O ALIGNMENT PINS & WITH CAP	3	2.80	3.7	

TABLE 3 - WITH ALIGNMENT PINS AND KAPTON TAPE					
PART NUMBER	PART DESCRIPTION	NO. OF POSITIONS	DIM B	DIM C	
11828-2AA	RECEPTACLE ASSEMBLY, 10 POSITION, W/ ALIGNMENT PINS & TAPE	10	7.00	7.9	
11828-2BA	RECEPTACLE ASSEMBLY, 20 POSITION, W/ ALIGNMENT PINS & TAPE	20	13.00	13.9	
11828-2CA	RECEPTACLE ASSEMBLY, 30 POSITION, W/ ALIGNMENT PINS & TAPE	30	19.00	19.9	
11828-2DA	RECEPTACLE ASSEMBLY, 40 POSITION, W/ ALIGNMENT PINS & TAPE	40	25.00	25.9	
11828-2EA	RECEPTACLE ASSEMBLY, 50 POSITION, W/ ALIGNMENT PINS & TAPE	50	31.00	31.9	
11828-2FA	RECEPTACLE ASSEMBLY, 60 POSITION, W/ ALIGNMENT PINS & TAPE	60	37.00	37.9	
11828-2GA	RECEPTACLE ASSEMBLY, 70 POSITION, W/ ALIGNMENT PINS & TAPE	70	43.00	43.9	
11828-2HA	RECEPTACLE ASSEMBLY, 15 POSITION, W/ ALIGNMENT PINS & TAPE	15	10.00	10.9	
11828-2JA	RECEPTACLE ASSEMBLY, 3 POSITION, W/ ALIGNMENT PINS & TAPE	3	2.80	3.7	

TABLE 4 - WITHOUT ALIGNMENT PINS AND WITH KAPTON TAPE					
PART NUMBER	PART DESCRIPTION	NO. OF POSITIONS	DIM B	DIM C	
11828-2AB	RECEPTACLE ASSEMBLY, 10 POSITION, W/O ALIGNMENT PINS WITH TAPE	10	7.00	7.9	
11828-2BB	RECEPTACLE ASSEMBLY, 20 POSITION, W/O ALIGNMENT PINS WITH TAPE	20	13.00	13.9	
11828-2CB	RECEPTACLE ASSEMBLY, 30 POSITION, W/O ALIGNMENT PINS WITH TAPE	30	19.00	19.9	
11828-2DB	RECEPTACLE ASSEMBLY, 40 POSITION, W/O ALIGNMENT PINS WITH TAPE	40	25.00	25.9	
11828-2EB	RECEPTACLE ASSEMBLY, 50 POSITION, W/O ALIGNMENT PINS WITH TAPE	50	31.00	31.9	
11828-2FB	RECEPTACLE ASSEMBLY, 60 POSITION, W/O ALIGNMENT PINS WITH TAPE	60	37.00	37.9	
11828-2GB	RECEPTACLE ASSEMBLY, 70 POSITION, W/O ALIGNMENT PINS WITH TAPE	70	43.00	43.9	
11828-2HB	RECEPTACLE ASSEMBLY, 15 POSITION, W/O ALIGNMENT PINS WITH TAPE	15	10.00	10.9	
11828-2JB	RECEPTACLE ASSEMBLY, 3 POSITION, W/O ALIGNMENT PINS WITH TAPE	3	2.80	3.7	

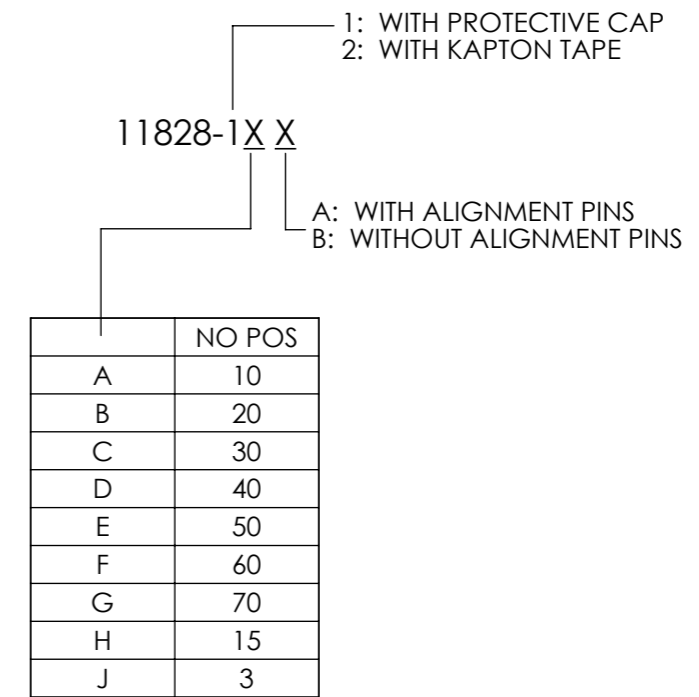

EXAMPLE SHOWN: 10 POSITION, WITH ALIGNMENT PINS = 11828-1AA

**Amphenol** 825 OLD TRAIL ROAD  
 ETTERS, PA 17319  
 AMPHENOL INTERCON SYSTEMS INC. 717-915-1400

TOLERANCES UNLESS SPECIFIED OTHERWISE  .XXX ± 0.05 .XX ± 0.13 .X ± 0.3 ANGLES ± 1°	ALL DIMENSIONS AND TOLERANCES PER ASME Y14.5M  ALL DIMENSIONS ARE IN <b>MILLIMETERS</b> UNLESS OTHERWISE SPECIFIED	PART LYNX RECEPTACLE ASSEMBLY 0.6mm PITCH		DRAWING <b>11828C</b> CUSTOMER	
	THIRD ANGLE PROJECTION 	INSPECTION ◇ FIRST PIECE ○ IN-PROCESS △ SPC	DRAWN	DATE 10/28/2020	DEPT NO 45
		ENGR/APV	DATE	SCALE 10:1	SHEET 3 OF 5

THIS DOCUMENT CONTAINS CONFIDENTIAL AND PROPRIETARY INFORMATION OF AMPHENOL INTERCON SYSTEMS AND MAY NOT BE DISCLOSED, REPRODUCED OR OTHERWISE USED WITHOUT WRITTEN PERMISSION

# RECEPTACLE CONNECTOR W/KAPTON TAPE

## TAPE AND REEL PACKAGING

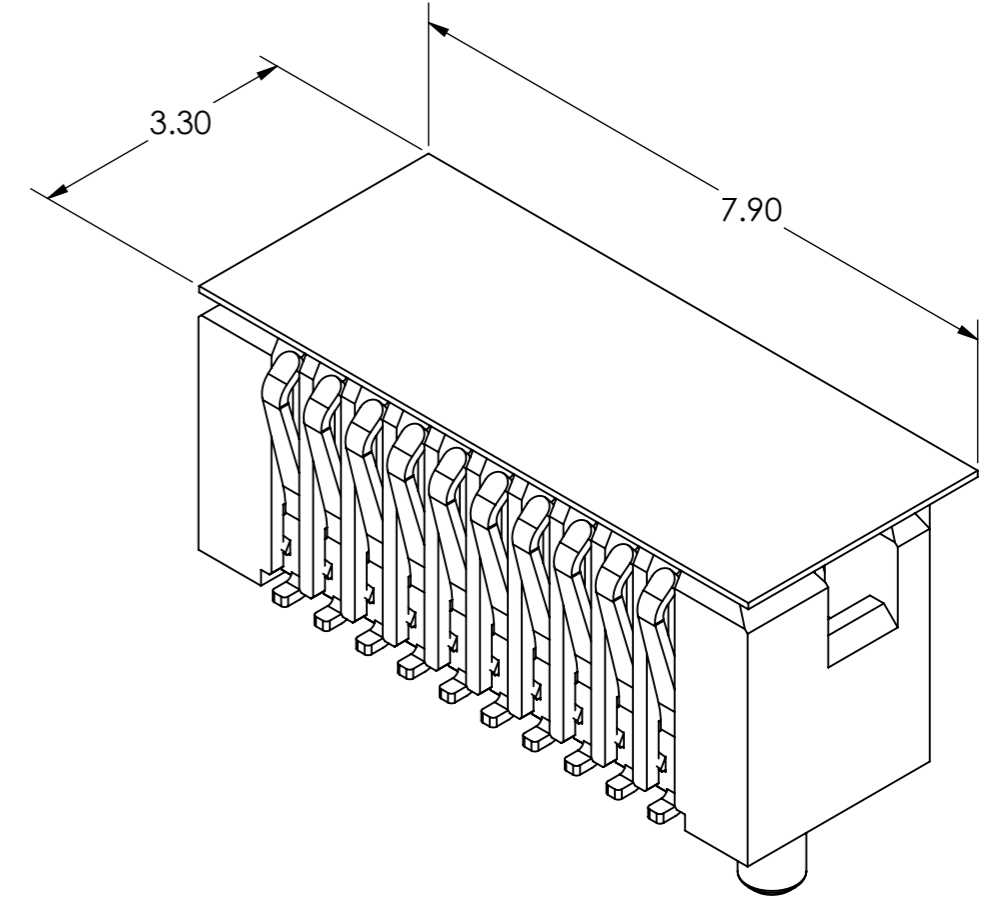
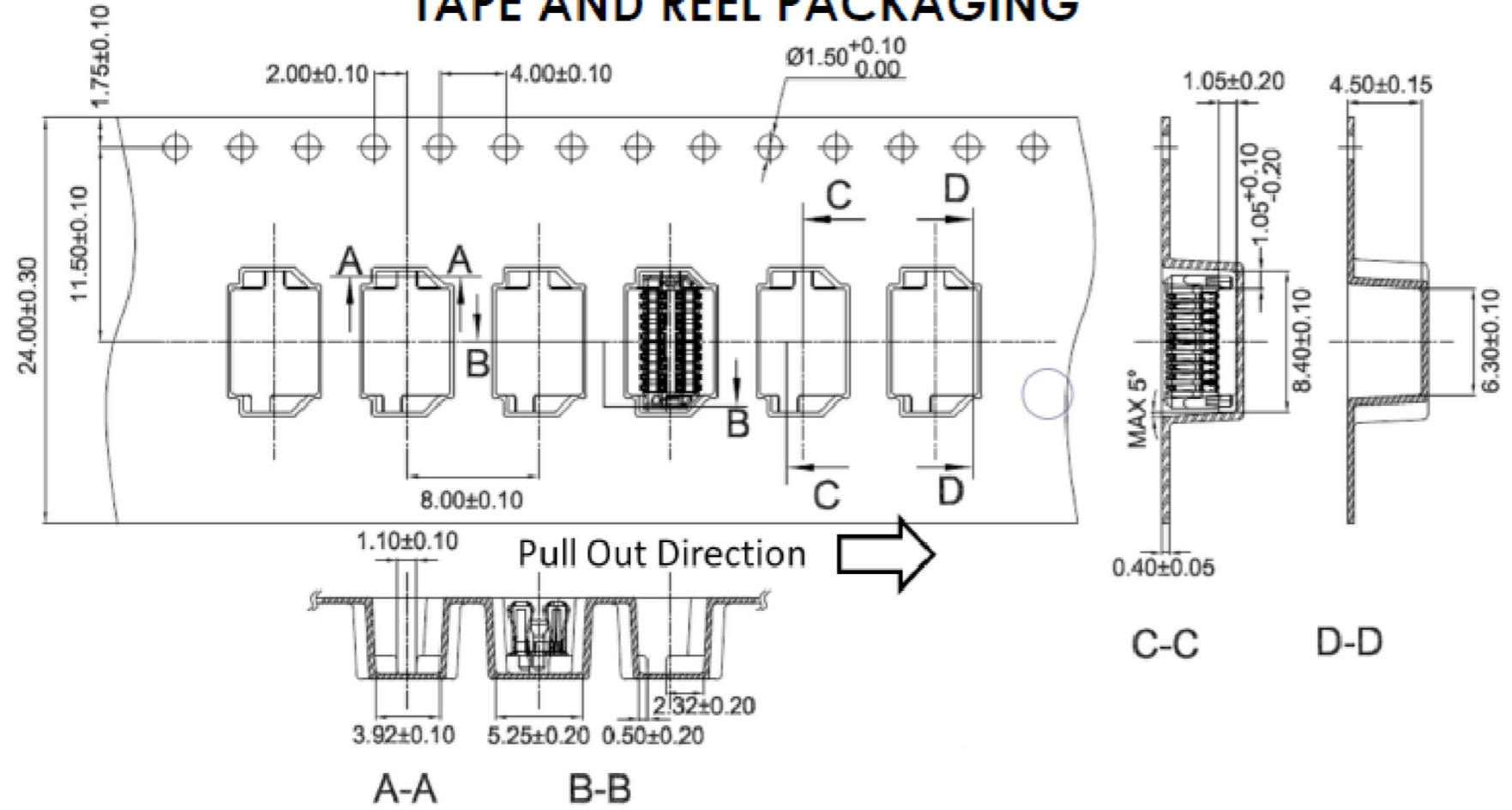

\*5MM RECEPTACLE 10 POSITION TAPE AND REEL SHOWN

POS	TAPE WIDTH
3	24.00 +/- 0.30 MM
10	24.00 +/- 0.30 MM
15	32.00 +/- 0.30 MM
20	32.00 +/- 0.30 MM
30	32.00 +/- 0.30 MM
40	44.00 +/- 0.30 MM
50	56.00 +/- 0.30 MM
60	56.00 +/- 0.30 MM
70	56.00 +/- 0.30 MM

KAPTON TAPE			
POS	LENGTH	WIDTH	THICKNESS
3	3.70 MM	3.3 MM	0.08 MM
10	7.90 MM	3.3 MM	0.08 MM
15	10.90MM	3.3 MM	0.08 MM
20	13.90 MM	3.3 MM	0.08 MM
30	19.90 MM	3.3 MM	0.08 MM
40	25.90 MM	3.3 MM	0.08 MM
50	31.90 MM	3.3 MM	0.08 MM
60	37.90 MM	3.3 MM	0.08 MM
70	43.90 MM	3.3 MM	0.08 MM

## WITH ALIGNMENT POSTS

<b>TOLERANCES</b> UNLESS SPECIFIED OTHERWISE .XXX ± 0.05 .XX ± 0.13 X ± 0.3 ANGLES ± 1°	ALL DIMENSIONS AND TOLERANCES PER ASME Y14.5M ALL DIMENSIONS ARE IN <b>MILLIMETERS</b> UNLESS OTHERWISE SPECIFIED	PART <b>LYNX RECEPTACLE ASSEMBLY</b> 0.6mm PITCH		DRAWING <b>11828C</b> CUSTOMER	
	THIRD ANGLE PROJECTION 	INSPECTION ◇ FIRST PIECE ○ IN-PROCESS △ SPC	DRAWN ENGR/APV	DATE 10/28/2020	DEPT NO 45
				SCALE 10:1	SHEET 4 OF 5

**Amphenol** 825 OLD TRAIL ROAD  
 ETTERS, PA 17319  
 AMPHENOL INTERCON SYSTEMS INC. 717-915-1400

8 7 6 5 4 3 2 1

F

F

# RECEPTACLE CONNECTOR W/PROTECTIVE CAP

E

E

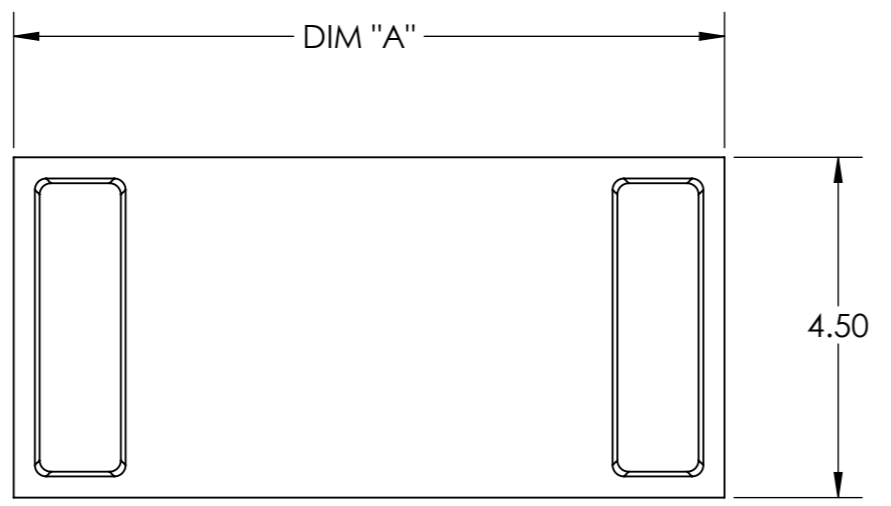

D

D

C

C

POS	DIM A
3	5.20
10	9.40
15	12.40
20	15.40
30	21.40
40	27.40
50	33.40
60	39.40
70	45.40

B

B

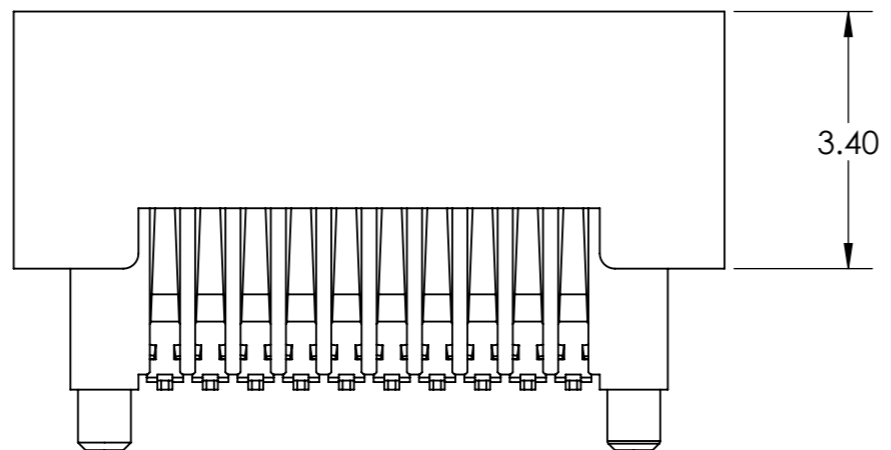

A

A

WITH ALIGNMENT POSTS

**Amphenol** 825 OLD TRAIL ROAD  
 ETTERS, PA 17319  
 AMPHENOL INTERCON SYSTEMS INC. 717-915-1400

TOLERANCES UNLESS SPECIFIED OTHERWISE .XXX ± 0.05 .XX ± 0.13 .X ± 0.3 ANGLES ± 1°	ALL DIMENSIONS AND TOLERANCES PER ASME Y14.5M ALL DIMENSIONS ARE IN <b>MILLIMETERS</b> UNLESS OTHERWISE SPECIFIED		PART LYNX RECEPTACLE ASSEMBLY 0.6mm PITCH		DRAWING <b>11828C</b> CUSTOMER	
	THIRD ANGLE PROJECTION 	INSPECTION ◇ FIRST PIECE ○ IN-PROCESS △ SPC	DRAWN ENGR/APV	DATE 10/28/2020	DEPT NO 45	REV J

THIS DOCUMENT CONTAINS CONFIDENTIAL AND PROPRIETARY INFORMATION OF AMPHENOL INTERCON SYSTEMS AND MAY NOT BE DISCLOSED, REPRODUCED OR OTHERWISE USED WITHOUT WRITTEN PERMISSION

6 5 4

## Looking for pricing, stock, or lifecycle information?

Click below to explore more details on WIN SOURCE:

 [View 11828-2CA on WIN SOURCE](#)

 [Amphenol Information](#)

## Optimize Your Supply Chain with WIN SOURCE Solutions

-  Global Sourcing Solution
-  Obsolete Management
-  Cost Control Management
-  Shortage Management
-  Alternative Solution
-  Excess Inventory Management