

LOC	DIST	REV	DATE	BY	CHK	APPV
AA	22	K1	18MAY2011	RK	HMR	
		L	27APR2015	LL	SH	

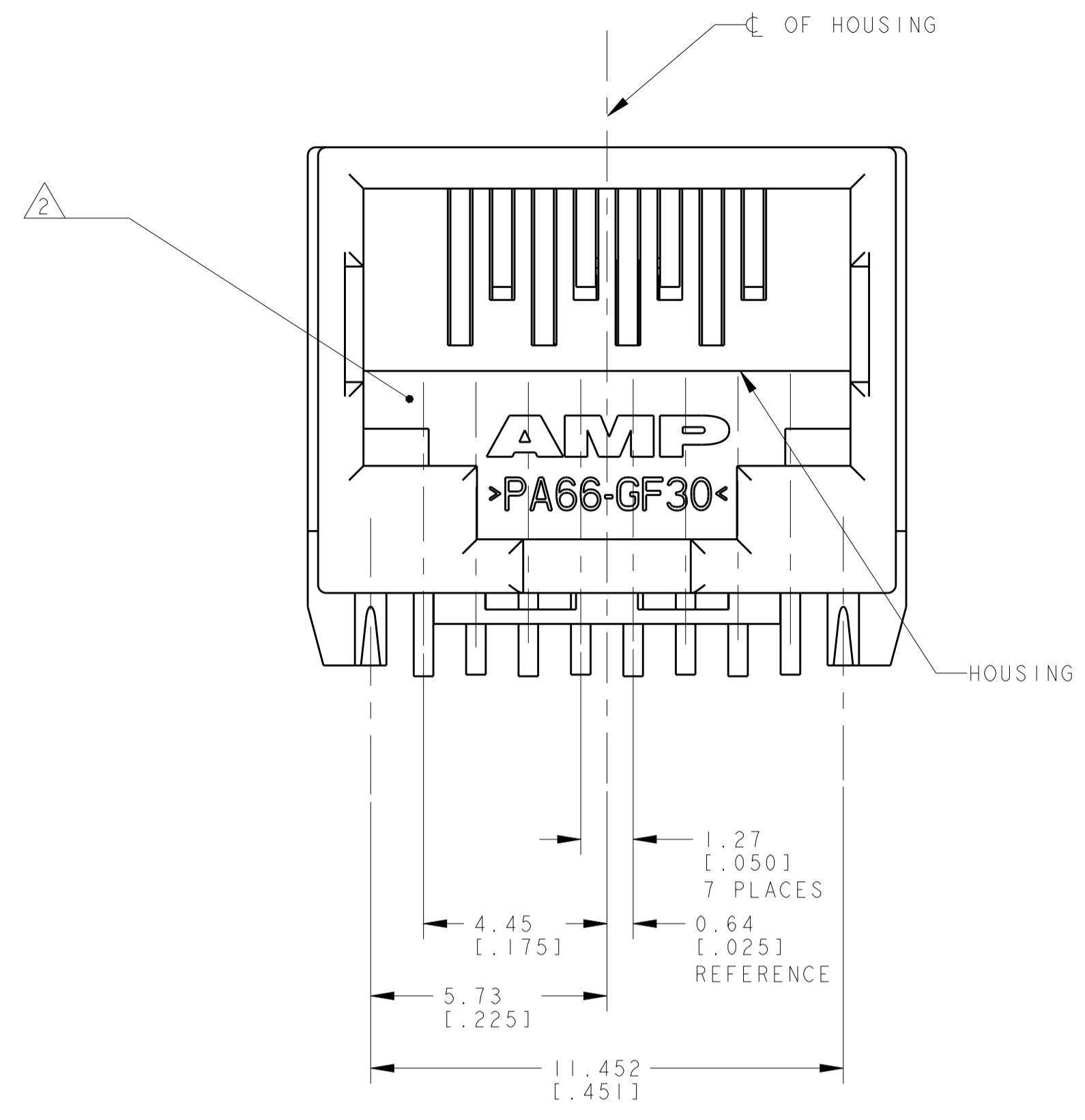

- 1. MATERIAL: HOUSING - HIGH TEMPERATURE NYLON, BLACK, UL 94V-0, IR REFLOW SOLDERING PROCESS COMPATIBLE. TERMINALS - 0.25[.010] THICK PHOSPHOR BRONZE PLATED WITH 3.81µm[.000150] MINIMUM THICK BRIGHT TIN-LEAD IN SOLDER AREA, 1.27µm[.000050] MINIMUM GOLD IN LOCALIZED PLATE AREA. ENTIRE TERMINAL PLATED WITH 1.27µm[.000050] MINIMUM THICK NICKEL.
- 2. JACK CAVITY CONFORMS TO FCC RULES AND REGULATIONS PART 68, SUBPART F.
- 3. THIS DIMENSION REPRESENTS THE TOTAL HEIGHT OF THE CONNECTOR FROM THE TOP OF THE PC BOARD.
- 4. PACKAGED 66 ASSEMBLIES PER PVC TRAY, 396 PER BOX.
- 5. MANUFACTURING DATE CODE: ORIENTED AND LOCATED APPROXIMATELY AS SHOWN. LASER PRINTING. TEXT HEIGHT APPROXIMATELY 2MM. FIRST 2 DIGITS = LAST 2 DIGITS OF YEAR. NEXT 2 DIGITS = MANUFACTURING WORK WEEK. LAST DIGIT = DAY OF WEEK WITH SUNDAY = 1.
- 6. MATERIAL: HOUSING - HIGH TEMPERATURE NYLON, BLACK, UL 94V-0, IR REFLOW SOLDERING PROCESS COMPATIBLE. TERMINALS - 0.25[.010] THICK PHOSPHOR BRONZE PLATED WITH 3.81µm[.000150] MINIMUM THICK MATTE TIN IN SOLDER AREA, 1.27µm[.000050] MINIMUM GOLD IN LOCALIZED PLATE AREA. ENTIRE TERMINAL PLATED WITH 1.27µm[.000050] MINIMUM THICK NICKEL.

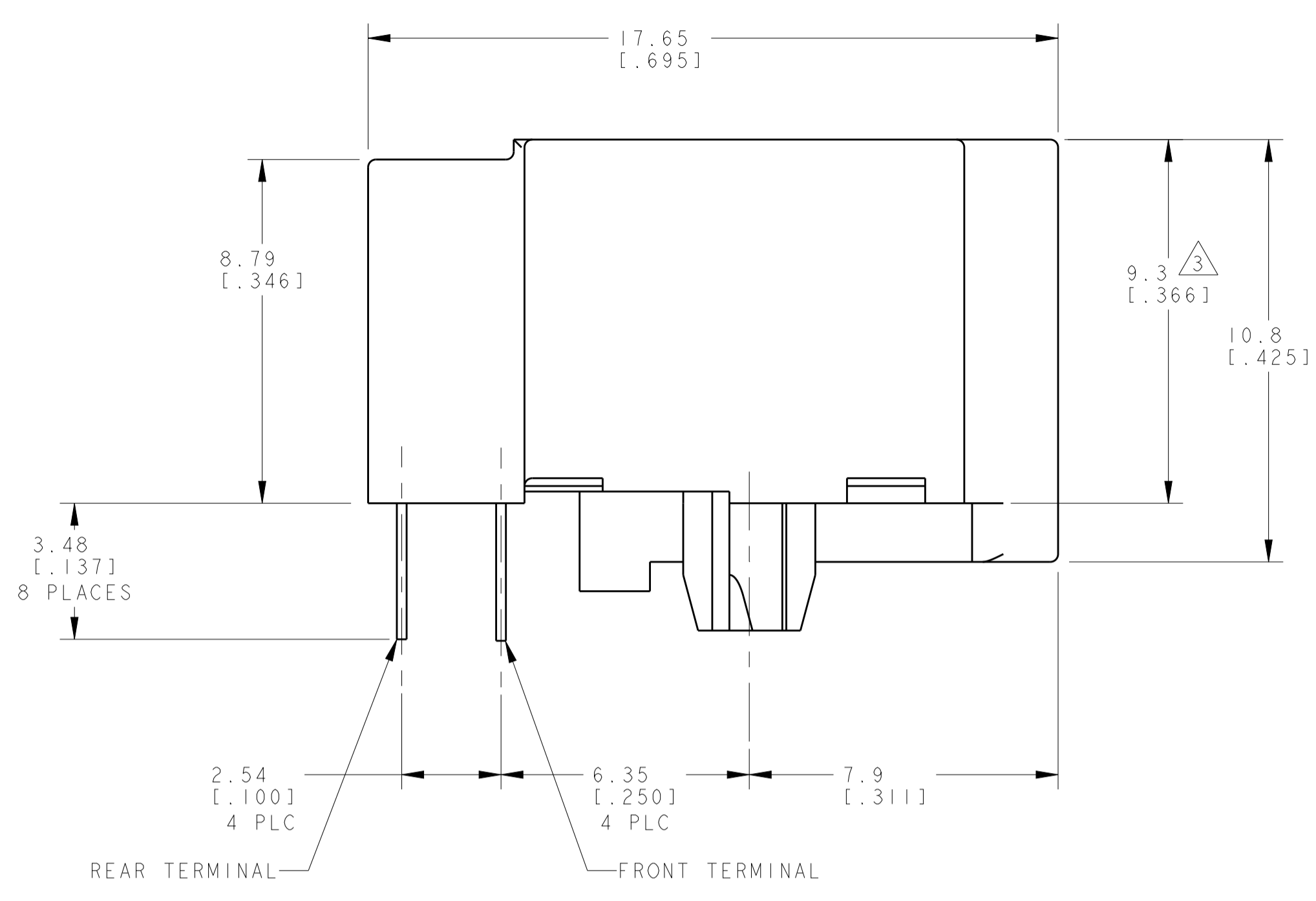
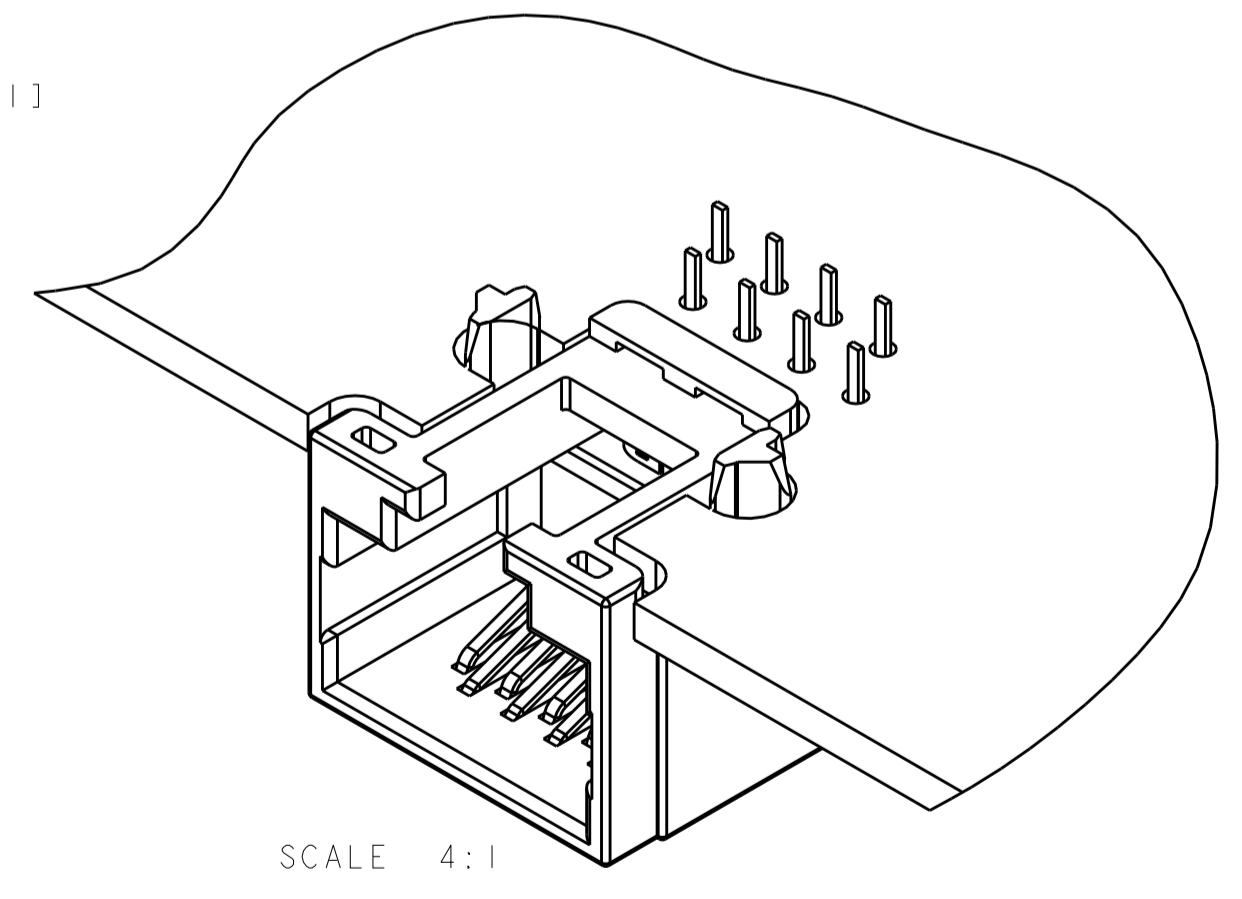
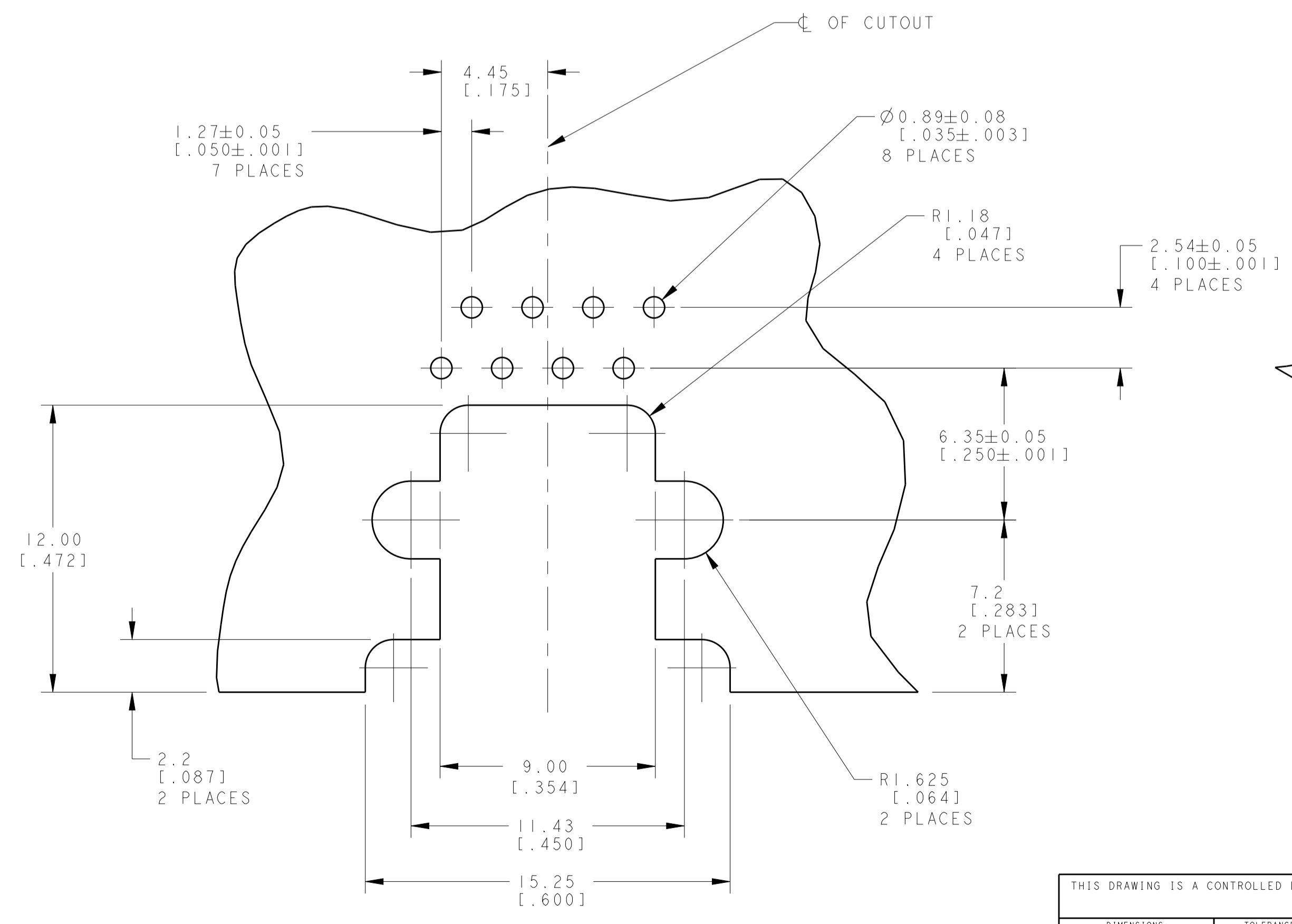
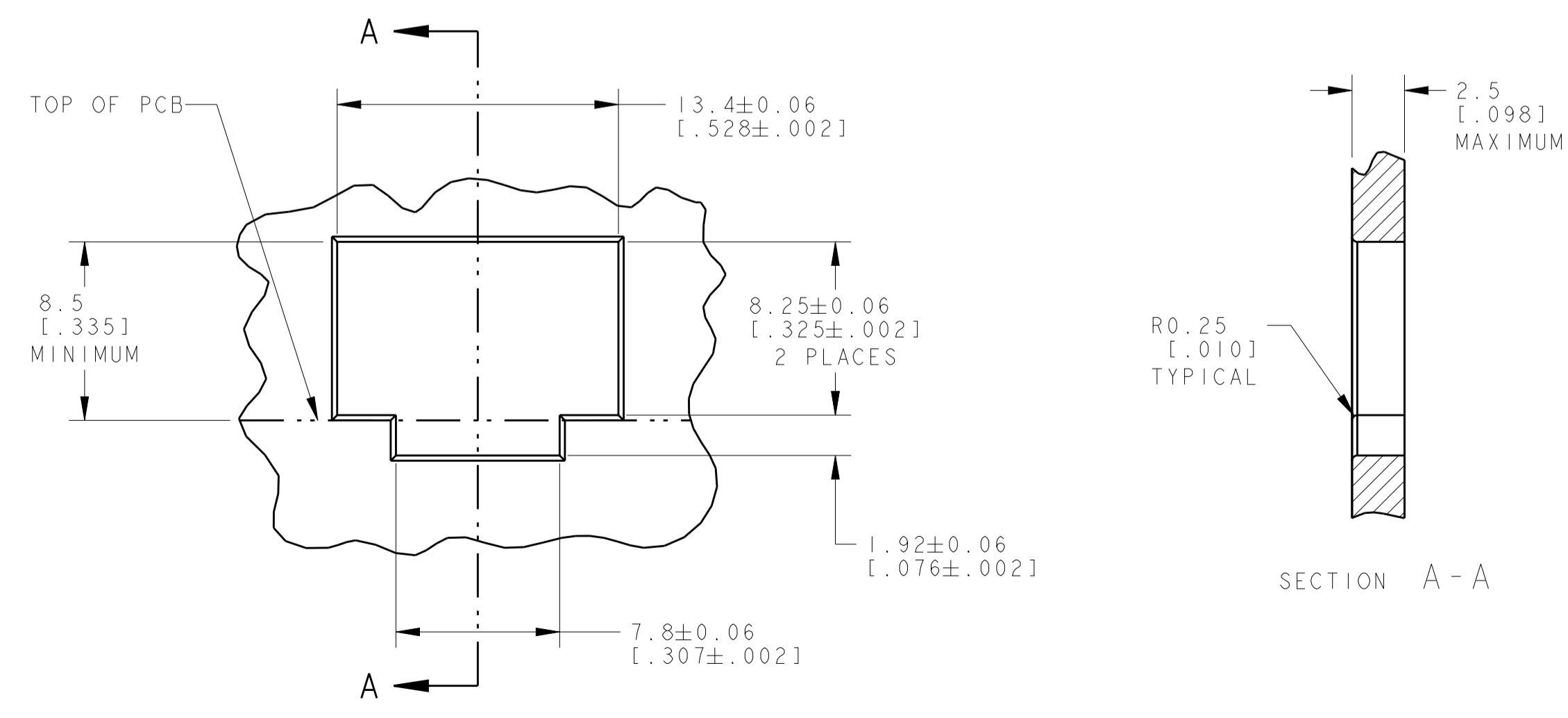
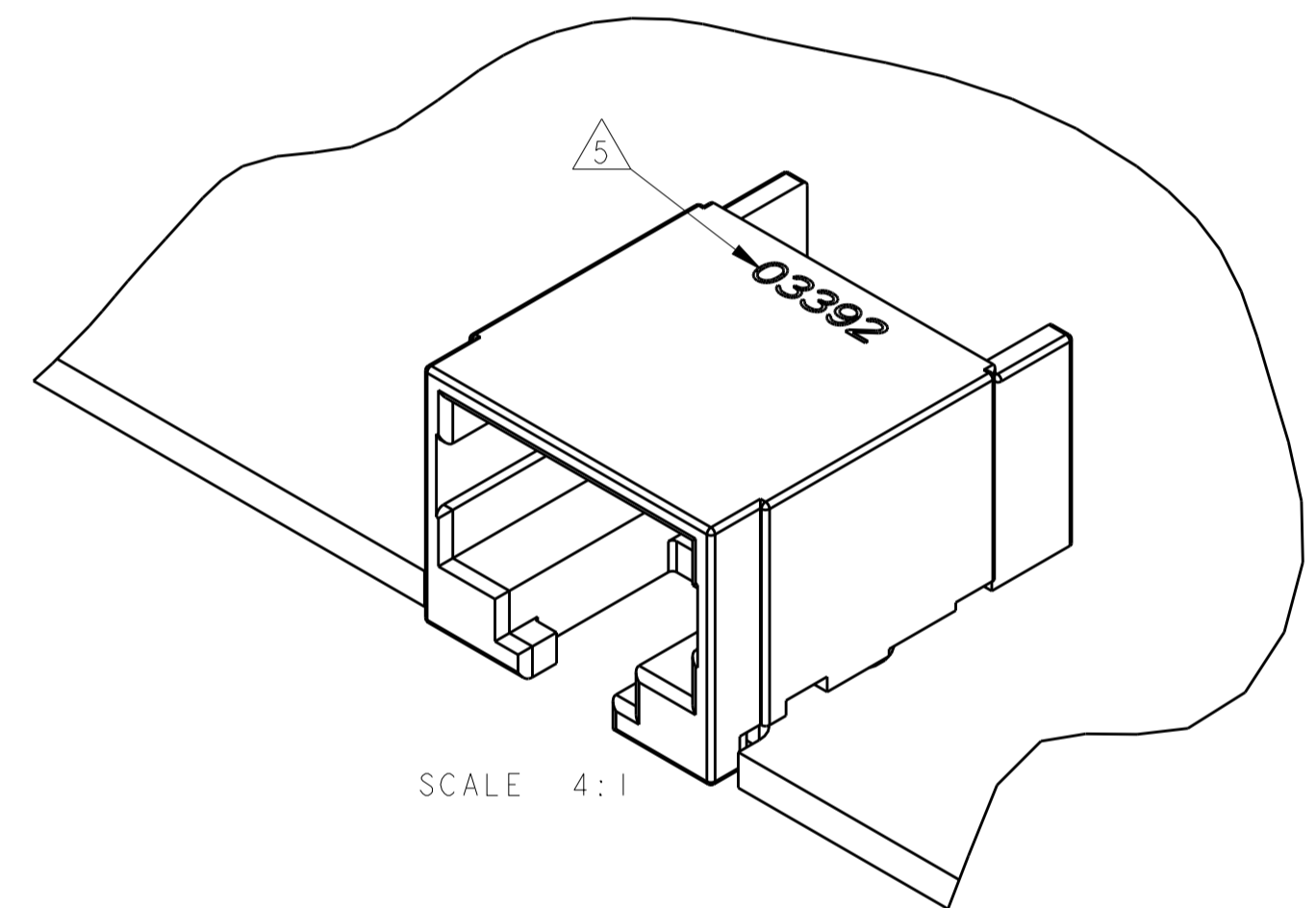
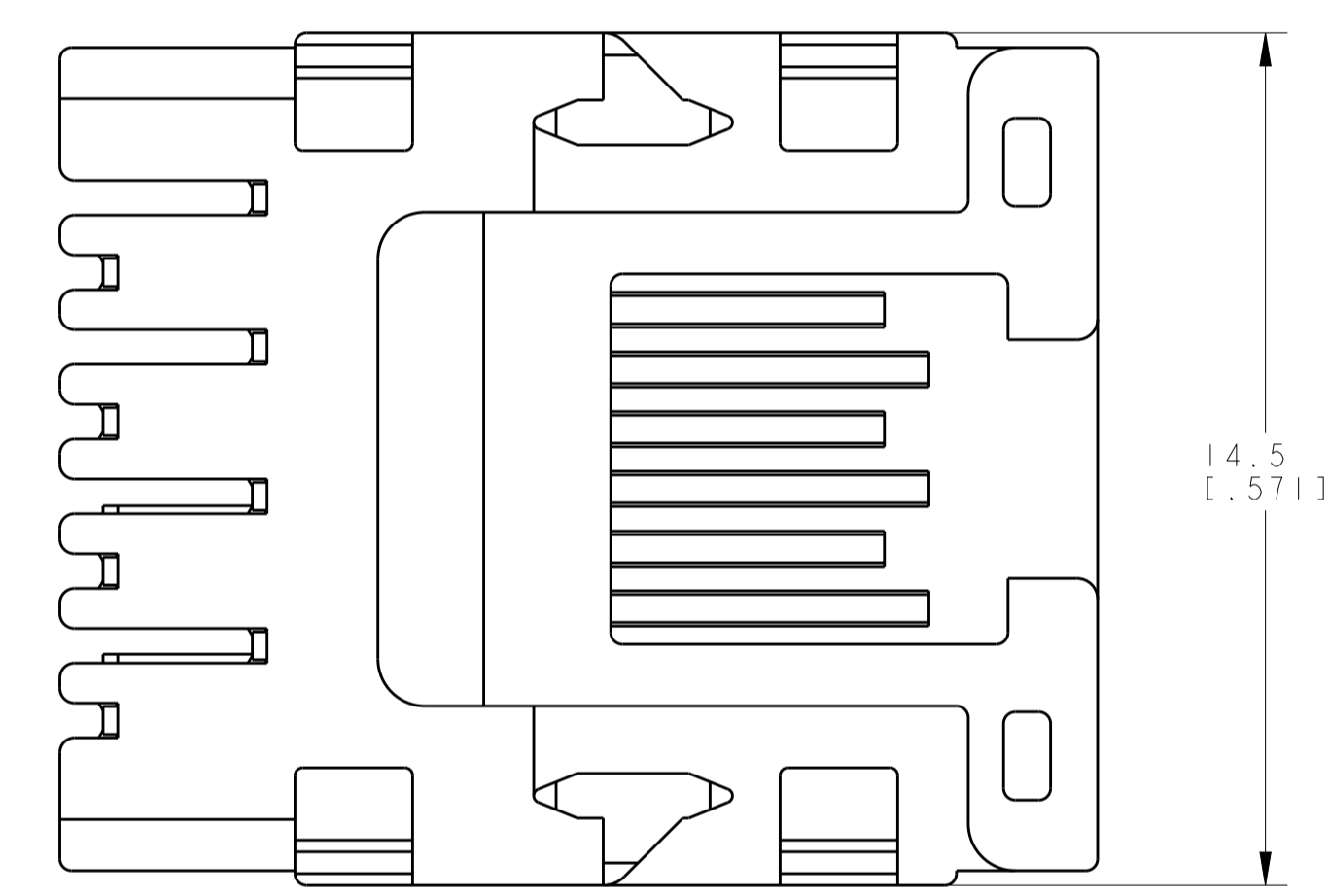

6	1116504-2
1	1116504-1
MATERIAL/ FINISH	PART NUMBER

THIS DRAWING IS A CONTROLLED DOCUMENT.		OWN: T. SPRINKLE 28JAN99	TE Connectivity
DIMENSIONS: mm [INCHES]		CHK: D. KEMPKA 28JAN99	NAME: MODULAR JACK ASSEMBLY, 8 POSITION, 10mm
TOLERANCES UNLESS OTHERWISE SPECIFIED:		APPV: D. KEMPKA 28JAN99	
0 PLC ±	1 PLC ±	PRODUCT SPEC	SIZE: CAGE CODE DRAWING NO: RESTRICTED TO
2 PLC ±	3 PLC ±	108-1163	
4 PLC ±	5 PLC ±	APPLICATION SPEC	WEIGHT: 3.49 grams A100779 ©=1116504
ANGLES ±		114-2048	
MATERIAL: SEE P/N TABLE	FINISH: SEE P/N TABLE	CUSTOMER DRAWING	SCALE: 8:1 SHEET: 1 OF 1 REV: L

Looking for pricing, stock, or lifecycle information?

Click below to explore more details on WIN SOURCE:

[View 1116504-2 on WIN SOURCE](#)

[TE Connectivity Information](#)

Optimize Your Supply Chain with WIN SOURCE Solutions

- ✓ Global Sourcing Solution
- ✓ Obsolete Management
- ✓ Cost Control Management
- ✓ Shortage Management
- ✓ Alternative Solution
- ✓ Excess Inventory Management