



**THE DATASHEET OF**  
**1115-6127**



# PRODUCT DATA DRAWING

REVISION HISTORY			
REV	DESCRIPTION	DATE	APPROVED
-	NRN 45704	03/21	SEE PDM

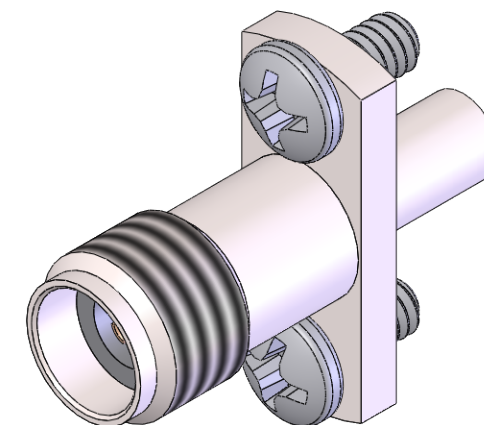
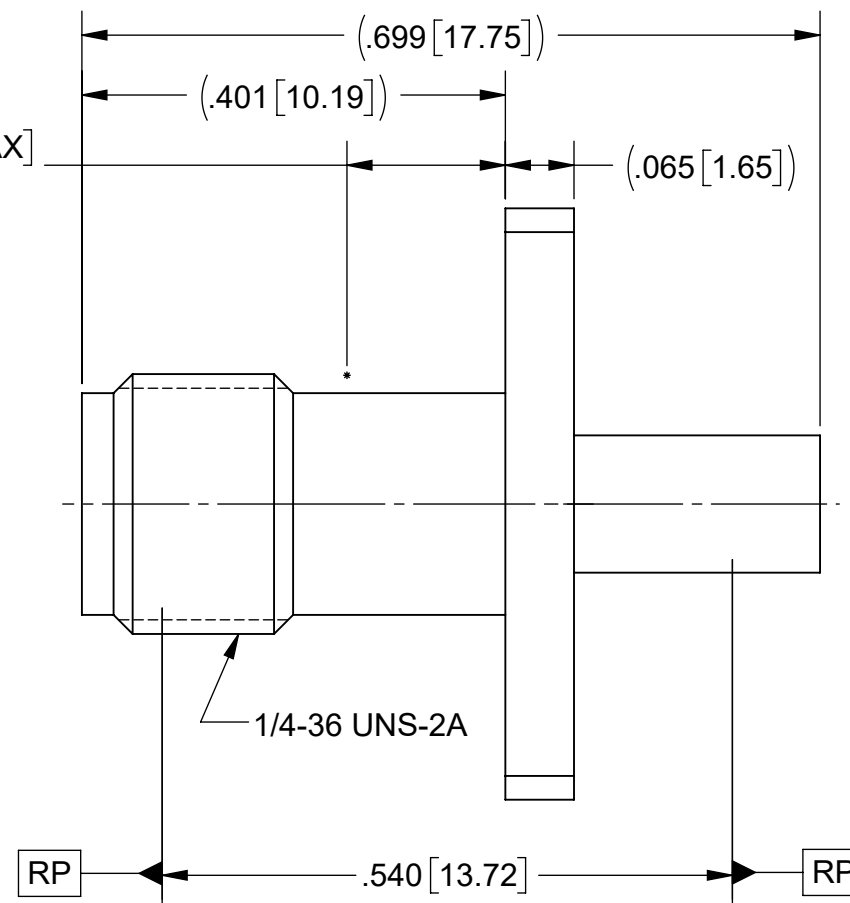
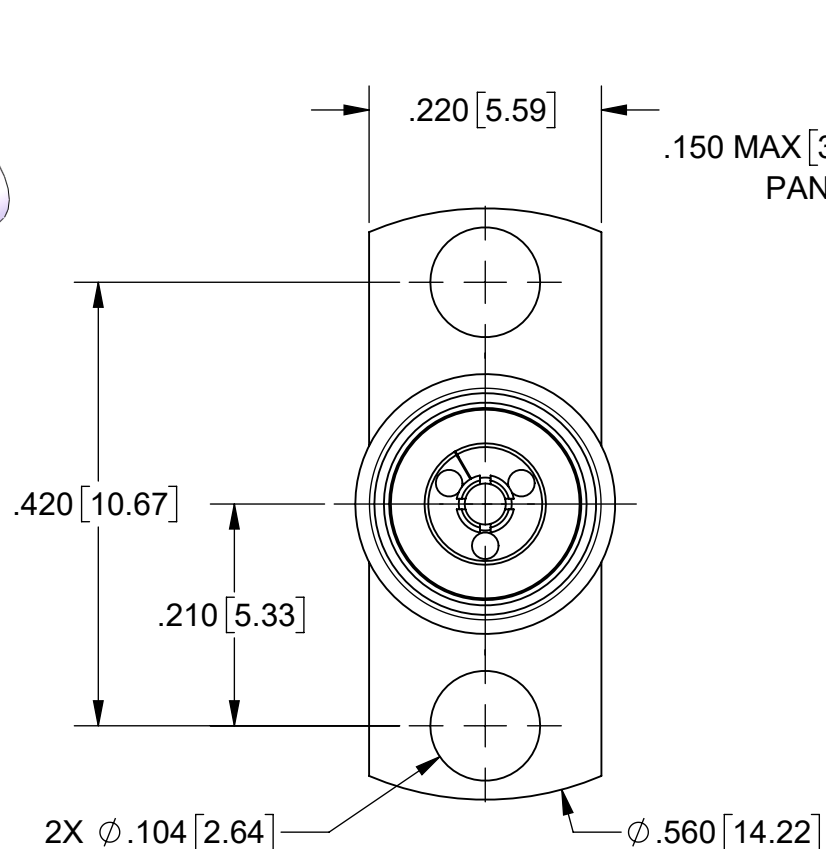
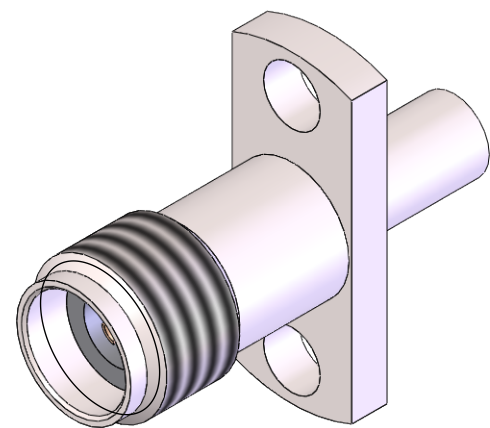

## MATERIAL:

- BODY, & SLEEVE:** STAINLESS STEEL PER AMS-5640, ALLOY UNS S30300, TYPE 1; OR ASTM A582 TYPE 303, COND. A
- CONTACT:** BERYLLIUM COPPER PER ASTM B196, ALLOY No. UNS C17300, TD04
- INSULATOR:** PTFE PER ASTM D1710, TYPE I, GRADE 1, CLASS B
- BEAD:** ULTEM 1000 PER ASTM D5205
- SCREWS:** 18-8 STAINLESS STEEL

## FINISH:

- BODY & SLEEVE:** PASSIVATED PER AMS-2700
- SCREWS:** PASSIVATED
- CONTACT:** GOLD PER ASTM B488, TYPE II, CODE C, CLASS 1.27, OVER NICKEL PER AMS-QQ-N-290, CLASS 1, .00005" MIN.

## PERFORMANCE:

- IMPEDANCE:** 50 OHMS
- FREQ. RANGE:** DC TO 40.0 GHz.

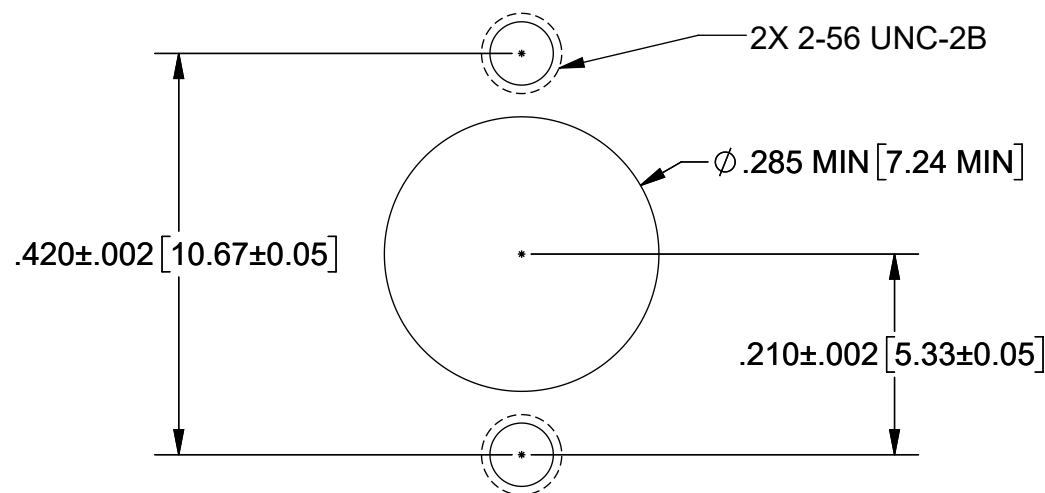

## RECOMMENDED MOUNTING HOLE

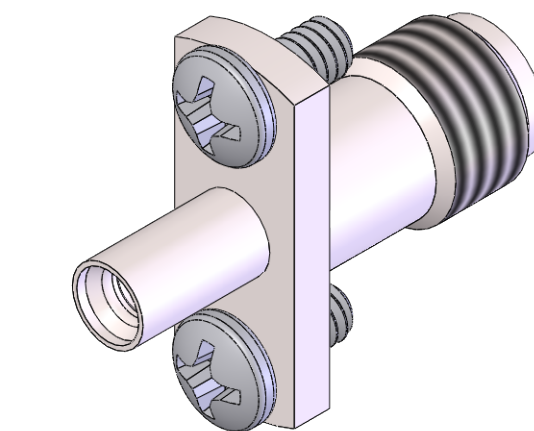

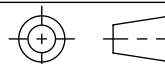

SV P/N	INTERFACE
1115-6126	FD
1115-6127	SB

MATERIAL: SEE NOTES	DIMENSIONS ARE IN INCHES TOLERANCES: FRACTIONAL: ±1/64 ANGULAR: X° ±1'0" X'X' ±15'	UNLESS OTHERWISE SPECIFIED 1) ALL DIMENSIONS ARE IN INCHES (MILLIMETERS) 2) ALL DIMENSIONS ARE AFTER PLATING. 3) BREAK CORNERS & EDGES .005 R. MAX. 4) CHAM. 1ST & LAST THREADS. 5) SURFACE ROUGHNESS 63-MIL-STD-10. 6) DIA: 'S ON COMMON CENTERS TO BE CONCENTRIC WITHIN .005 T.I.R. 7) REMOVE ALL BURRS	 TITLE: 2.92mm FEMALE TO SMPM MALE STRAIGHT 2 HOLE FLANGE ADAPTER SIZE DWG. NO. 1115-6126-6127 SCALE: 5.5:1 SHEET 1 OF 1
FINISH: SEE NOTES	DECIMAL: X ±.030 .XX ±.010 .XXX ±.005	INTERPRET DIMENSIONS AND TOLERANCES PER ASME Y14.5M - 1994	
SURFACE AREA: N/A	THIRD ANGLE PROJECTION	DRAWN: JLP 03/29/21	
PROPRIETARY THE INFORMATION CONTAINED IN THIS DRAWING IS THE SOLE PROPERTY OF SV MICROWAVE, INC. ANY REPRODUCTION IN PART OR AS A WHOLE WITHOUT THE WRITTEN PERMISSION OF SV MICROWAVE, INC IS PROHIBITED.		CHECKED: SEE PDM	
		APPROVED: SEE PDM	

## Looking for pricing, stock, or lifecycle information?

Click below to explore more details on WIN SOURCE:

-  [View 1115-6127 on WIN SOURCE](#)
-  [Amphenol SV Microwave](#) Information

## Optimize Your Supply Chain with WIN SOURCE Solutions

-  Global Sourcing Solution
-  Obsolete Management
-  Cost Control Management
-  Shortage Management
-  Alternative Solution
-  Excess Inventory Management