



**THE DATASHEET OF
PI3DBS16215ZBBEX**



PI3DBS16215

3.3V, 1-20Gbps 1-Lane 2:1 Mux/De-Mux Switch

Features

- Two Differential Channel, 2:1 Mux/DeMux
- Up to 20Gbps for Applications Including USB3.0, USB3.1, 10GE, Thunderbolt 3, and SAS3.0
- Bidirectional Operation
- 3dB Bandwidth: 14 GHz
- Low Bit-to-Bit Skew, 1ps typ
- Low Channel-to-Channel Skew, 7ps typ
- Low Insertion Loss: -1.3dB @ 5GHz, -1.3dB @ 8GHz, -2dB @ 10GHz
- Return Loss: -21dB @ 5GHz, -13dB @ 8GHz, -9dB @ 10GHz
- Low-Power Consumption - 300µA typ
- Supply Voltage 3.3V
- Industrial Temperature Range: -40°C to 85°C
- Totally Lead-Free & Fully RoHS Compliant (Notes 1 & 2)
- Halogen and Antimony Free. “Green” Device (Note 3)
- Packaging (Pb-free & Green):
 - 20-contact, TQFN (ZBB20), 2.5mm × 4.5mm

Description

The PI3DBS16215 is a 4-to-2 differential channel multiplexer/de-multiplexer switch. This solution can switch multiple signal types up to data rate of 20Gbps. Using a unique design technique, Diodes is able to minimize the impedance of the switch, so the attenuation observed through the switch is minimal. The unique design technique also offers a layout targeted for USB3.0, USB3.1, 10GE, Thunderbolt 3, and SAS3.0 signals, which minimizes the channel-to-channel skew as well as channel-to-channel crosstalk as required by high-speed signals.

Applications

- Routing high-speed differential signals, such as USB3.1 Gen 2, SAS3, PCIe4, TB3

Block Diagram

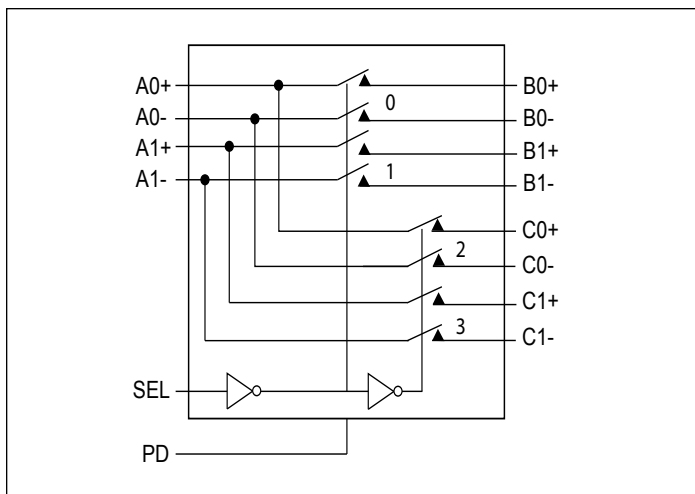

Ordering Information

Part Number	Package	Description
PI3DBS16215ZBBEX	ZBB	20-Contact, Very-Thin Quad-Flat No-Lead (TQFN)

Notes:

1. No purposely added lead. Fully EU Directive 2002/95/EC (RoHS), 2011/65/EU (RoHS 2) & 2015/863/EU (RoHS 3) compliant.
2. See <https://www.diodes.com/quality/lead-free/> for more information about Diodes Incorporated's definitions of Halogen- and Antimony-free, "Green" and Lead-free.
3. Halogen- and Antimony-free "Green" products are defined as those which contain <900ppm bromine, <900ppm chlorine (<1500ppm total Br + Cl) and <1000ppm antimony compounds.
4. E = Pb-free and Green
5. X suffix = Tape/Reel

Looking for pricing, stock, or lifecycle information?

Click below to explore more details on WIN SOURCE:

- ⊖ [View PI3DBS16215ZBBEX on WIN SOURCE](#)
- ⊖ [Diodes Incorporated Information](#)

Optimize Your Supply Chain with WIN SOURCE Solutions

- ✓ Global Sourcing Solution
- ✓ Obsolete Management
- ✓ Cost Control Management
- ✓ Shortage Management
- ✓ Alternative Solution
- ✓ Excess Inventory Management