



**THE DATASHEET OF  
HIP2210FRTZ-T**



## HIP2210, HIP2211

100V, 3A Source, 4A Sink, High Frequency Half-Bridge Drivers with HI/LI or Tri-Level PWM Input and Adjustable Dead Time

The [HIP2210](#) and [HIP2211](#) are 100V, 3A source, 4A sink high-frequency half-bridge NMOS FET drivers. The HIP2211 features standard HI/LI inputs and is pin-compatible with popular Renesas bridge drivers such as the HIP2101 and ISL2111. The HIP2210 features a tri-level PWM input with programmable dead time. Its wide operating supply range of 6V to 18V and integrated high-side bootstrap diode supports driving the high-side and low-side NMOS in 100V half-bridge applications.

These drivers feature strong 3A source, 4A sink drivers with very fast 15ns typical propagation delay and 2ns typical delay matching, making it optimal for high-frequency switching applications. VDD and boot UVLO protects against an undervoltage operation.

The tri-level input of the HIP2210 PWM pin controls the high-side and low-side drivers with a single pin. When the PWM input is at logic high, the high-side bridge FET is turned on and the low-side FET is off. When the input is at logic low, the low-side bridge FET is turned on and the high-side FET is turned off. When the input voltage is in the mid-level state, both the high-side and low-side bridge FETs are turned off. The PWM threshold levels are proportional to an external input reference voltage on the VREF pin, allowing PWM operation across a 2.7V to 5.5V logic range.

The HIP2210 is offered in a 10 Ld 4x4mm TDFN package. The HIP2211 is offered in 8 Ld SOIC, 8 Ld 4x4mm DFN, and 10 Ld 4x4mm TDFN packages.

### Related Literature

For a full list of related documents, visit our website:

- [HIP2210](#), [HIP2211](#) device pages

### Features

- HIP2211 drop-in replacement for the ISL2111 and HIP2101 8 Ld SOIC, 8 Ld DFN, and 10 Ld TDFN packages
- 115V<sub>DC</sub> bootstrap supply maximum voltage supports 100V on the half-bridge
- 3A source and 4A sink gate drivers for NMOS FETs
- Fast propagation delay and matching: 15ns typical delay; 2ns typical matching (HIP2211)
- Integrated 0.5Ω typical bootstrap diode
- Wide 6V to 18V operating voltage range
- VDD and boot Undervoltage Lockout (UVLO)
- Robust noise tolerance: wide hysteresis at inputs; HS pin tolerates up to -10V continuous
- HIP2211: HI/LI inputs 3.3V logic compatible with VDD voltage tolerance
- HIP2210: Tri-Level PWM input with logic threshold levels set by external VREF pin from 2.7V to 5.5V
- HIP2210: Programmable dead time prevents shoot-through; adjustable from 35ns to 350ns with a single resistor

### Applications

- Telecom half-bridge and full-bridge DC/DC converters
- 3-phase BLDC motor driver; H-Bridge motor driver
- Two-switch forward and active clamp converters
- Multiphase PWM DC/DC controllers
- Class-D amplifiers

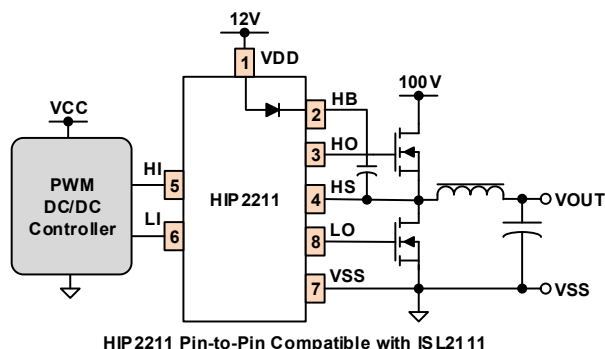

Figure 1. HIP2211 HI/LI Input Bridge Driver Typical Application

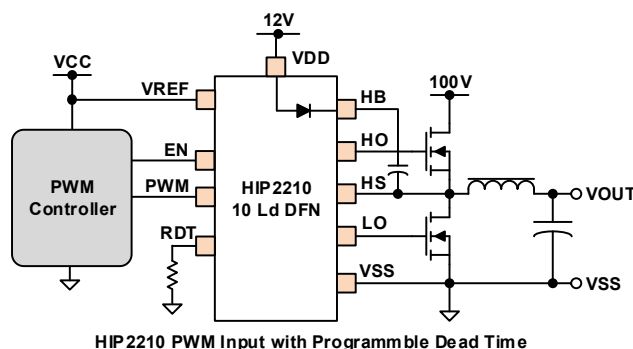

Figure 2. HIP2210 PWM Input Bridge Driver Typical Application

## Contents

<b>1. Overview</b>	<b>3</b>
1.1 Block Diagrams	3
1.2 Ordering Information	4
1.3 Pin Configurations	4
1.4 Pin Descriptions	5
<b>2. Specifications</b>	<b>6</b>
2.1 Absolute Maximum Ratings	6
2.2 Thermal Information	6
2.3 Recommended Operating Conditions	7
2.4 Electrical Specifications	7
2.5 Switching Specifications	9
2.6 Timing Diagrams	12
<b>3. Typical Performance Curves</b>	<b>13</b>
<b>4. Functional Description</b>	<b>17</b>
4.1 Gate Drive for NMOS Half-Bridge	17
4.2 Functional Overview	17
<b>5. Applications Information</b>	<b>18</b>
5.1 HI/LI Input Control (HIP2211 Only)	18
5.2 PWM Input Control (HIP2210 Only)	18
5.3 VREF Input (HIP2210 Only)	18
5.4 EN Pin (HIP2210 Only)	18
5.5 Power Sequencing HIP2210	18
5.6 Selecting the Boot Capacitor Value	19
5.7 VDD Decoupling Capacitor	20
5.8 RDT and Dead Time Delay (HIP2210 Only)	20
5.9 HO and LO Outputs	20
5.10 Power Dissipation	20
<b>6. PCB Layout Guidelines</b>	<b>22</b>
6.1 PCB Layout and EPAD Recommendation	23
<b>7. Revision History</b>	<b>24</b>
<b>8. Package Outline Drawings</b>	<b>25</b>

# 1. Overview

## 1.1 Block Diagrams

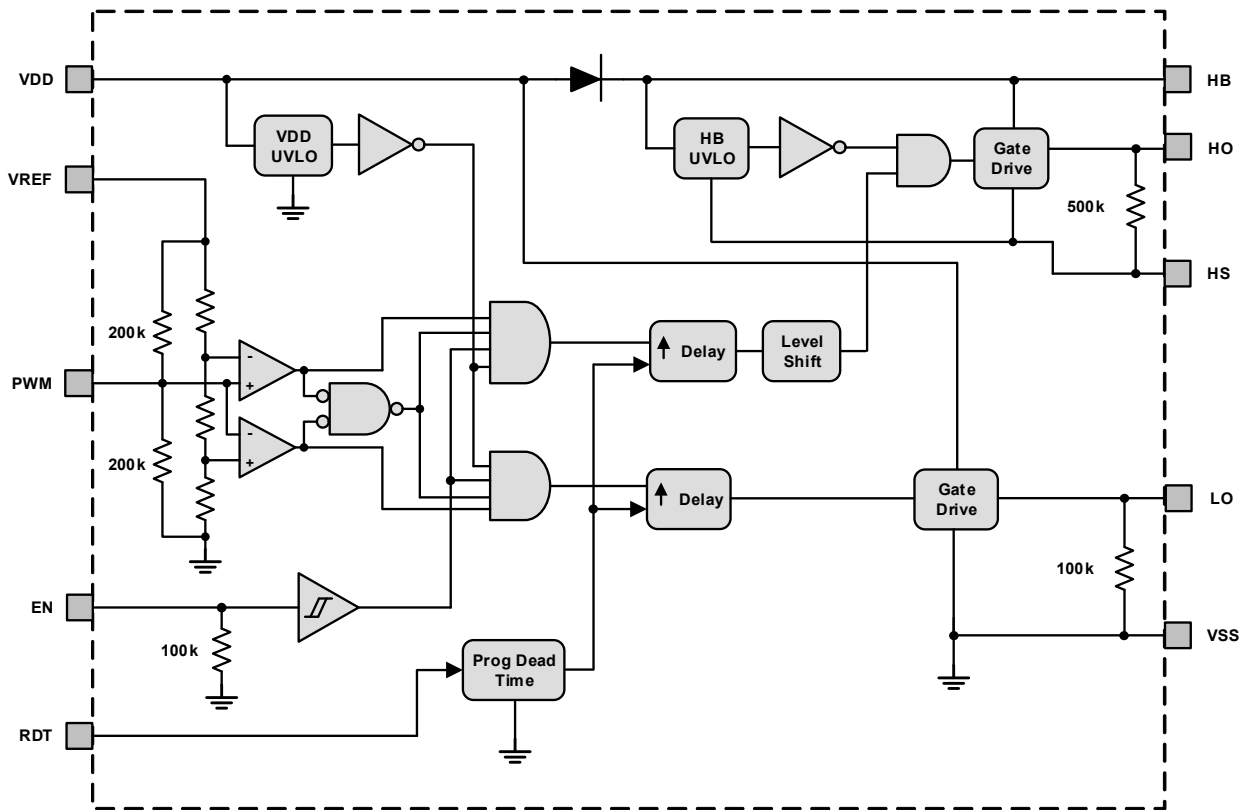

Figure 3. HIP2210 Block Diagram

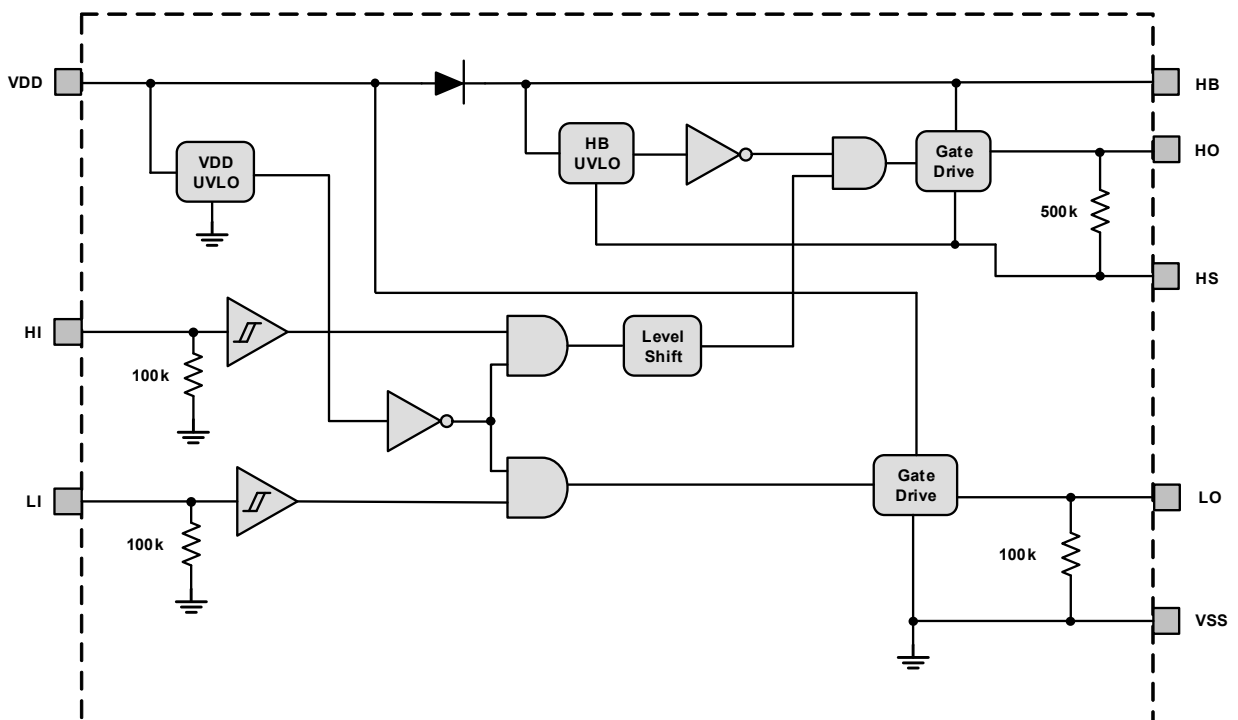

Figure 4. HIP2211 Block Diagram

## 1.2 Ordering Information

Part Number (Note 4)	Part Marking	Temp. Range (°C)	Tape and Reel (Units) (Note 1)	Package (RoHS Compliant)	Pkg. Dwg. #
HIP2210FRTZ (Note 2)	HIP221 0FRTZ	-40°C to +125°C	-	10 Ld 4x4 DFN	L10.4x4
HIP2210FRTZ-T (Note 2)			6k		
HIP2210FRTZ-T7A (Note 2)			250		
HIP2211FRTZ (Note 2)	HIP221 1FRTZ		-	10 Ld 4x4 DFN	L10.4x4
HIP2211FRTZ-T (Note 2)			6k		
HIP2211FRTZ-T7A (Note 2)			250		
HIP2211FBZ (Note 3)	2211 FBZ		-	8 Ld SOIC	M8.15
HIP2211FBZ-T (Note 3)			2.5k		
HIP2211FBZ-T7A (Note 3)			250		
HIP2211FR8Z (Note 2)	HIP221 1FR8Z	-	8 Ld 4x4 DFN	L8.4x4	
HIP2211FR8Z-T (Note 2)		6k			
HIP2211FR8Z-T7A (Note 2)		250			
HIP2210EVAL1Z	HIP2210 Evaluation Board				
HIP2211EVAL2Z	HIP2211 (SOIC Package) Evaluation Board				
HIP2211EVAL3Z	HIP2211 (10Ld TDFN Package) Evaluation Board				

### Notes:

- See [TB347](#) for details about reel specifications.
- These Pb-free plastic packaged products employ special Pb-free material sets, molding compounds/die attach materials, and 100% matte tin plate plus anneal (e3 termination finish, which is RoHS compliant and compatible with both SnPb and Pb-free soldering operations). Pb-free products are MSL classified at Pb-free peak reflow temperatures that meet or exceed the Pb-free requirements of IPC/JEDEC J-STD-020.
- These Pb-free plastic packaged products employ special Pb-free material sets; molding compounds/die attach materials and NiPdAu-Ag plate - e4 termination finish, which is RoHS compliant and compatible with both SnPb and Pb-free soldering operations. Pb-free products are MSL classified at Pb-free peak reflow temperatures that meet or exceed the Pb-free requirements of IPC/JEDEC J-STD-020.
- For Moisture Sensitivity Level (MSL), see the [HIP2210](#) and [HIP2211](#) device pages. For more information about MSL, see [TB363](#).

## 1.3 Pin Configurations

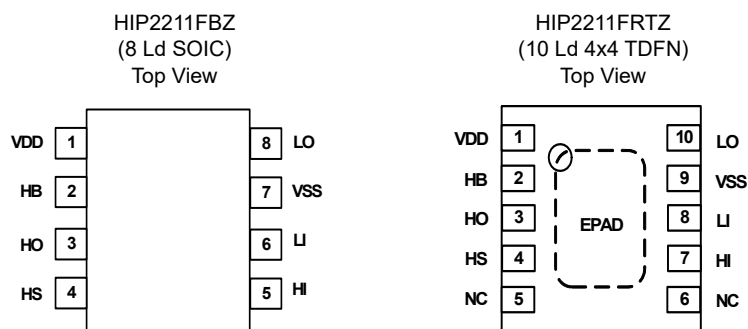

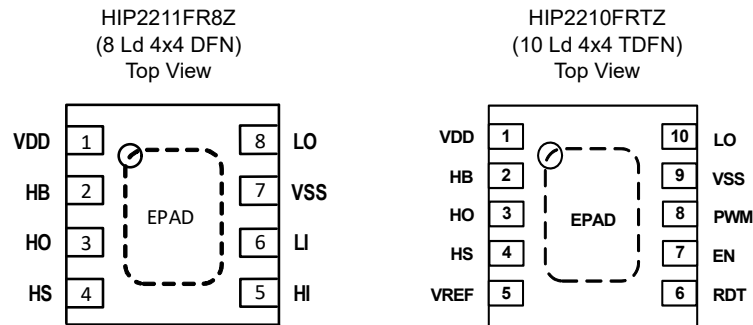

## 1.4 Pin Descriptions

Pin Name	Pin Number				Description
	HIP2210	HIP2211			
	10 Ld DFN	10 Ld DFN	8 Ld SOIC	8 Ld DFN	
VDD	1	1	1	1	Analog input supply voltage and positive supply for the lower gate driver. Decouple this pin to ground with a 4.7 $\mu$ F or larger high-frequency ceramic capacitor to VSS. An additional 0.1 $\mu$ F ceramic decoupling capacitor placed close to VDD and VSS pin is recommended.
HB	2	2	2	2	High-side bootstrap supply voltage for the upper gate driver referenced to HS. Connect the bootstrap capacitor to this pin and HS.
HO	3	3	3	3	High-side output driver. Connect to the gate of the high-side NMOS FET.
HS	4	4	4	4	High-side gate driver reference node. Connect to the source of the high-side NMOS FET. Connect the bootstrap capacitor to this pin and HB.
HI	-	7	5	5	High-side driver logic input. 3.3V logic compatible and VDD tolerant.
LI	-	8	6	6	Low-side driver logic input. 3.3V logic compatible and VDD tolerant.
VREF	5	-	-	-	Reference voltage that sets the PWM logic level thresholds. Analog supply range of 2.7V to 5.5V. Decouple VREF to VSS with a 0.1 $\mu$ F ceramic capacitor. If VREF is below 2.7V, the PWM inputs are ignored and HO = LO = 0. An internal 100k $\Omega$ pull-down resistor places VREF in the low state when the pin is left floating.
RDT	6	-	-	-	Programmable dead time control pin. Place a resistor from the RDT pin to VSS to set the dead time from 35ns to 350ns. The resistor range is 10k $\Omega$ to 100k $\Omega$ . Short the RDT pin to VSS to set the dead time to 15ns. See <a href="#">"PCB Layout Guidelines" on page 22</a> and <a href="#">"RDT and Dead Time Delay (HIP2210 Only)" on page 20</a> for more information.
EN	7	-	-	-	Output enable pin. When EN is low, HO = LO = 0. An internal 100k $\Omega$ pull-down resistor places EN in the low state when the pin is left floating. Output is enabled when EN is high (VDD tolerant).
PWM	8	-	-	-	Tri-level PWM input. Logic high drives HO high and LO low. Logic low drives HO low and LO high. In the mid-level state, both outputs are driven low. An internal resistor network biases the PWM pin to 50% of VREF when the pin is left floating to set the mid-level state.
VSS	9	9	7	7	Ground reference for the VDD supply. When EPAD is available, connect VSS to EPAD.
LO	10	10	8	8	Low-side output driver. Connect to the gate of the low-side NMOS FET.
NC	-	5, 6	-	-	No Connect. No electrical connection from this pin to the IC.
-	EPAD	EPAD	-	EPAD	The EPAD is electrically isolated. Connect the EPAD to the PCB ground plane with thermal vias for heat removal. See <a href="#">"PCB Layout Guidelines" on page 22</a> for more information.

## 2. Specifications

### 2.1 Absolute Maximum Ratings

Parameter ( <a href="#">Note 5</a> )	Minimum	Maximum	Unit
Supply Voltage, VDD	-0.3	+20	V
Boot Voltage, HB Referenced to HS	-0.3	+20	V
Bootstrap Voltage, HB Referenced to VSS	-0.3	+120	V
Bootstrap Voltage, HB Referenced to VDD	-0.3	+110	V
Continuous Voltage on HS	The greater of [-10 or -(20 - V <sub>DD</sub> )]	+120	V
EN, HI, and LI Voltage	-0.3	V <sub>DD</sub> + 0.3	V
PWM, VREF, RDT Voltage	-0.3	+6	V
Voltage on LO	-0.3	V <sub>DD</sub> + 0.3	V
Transient Voltage on LO (Repetitive Transient for 100ns)	-2	-	V
Voltage on HO	V <sub>HS</sub> - 0.3	V <sub>HB</sub> + 0.3	V
Transient Voltage on HO (Repetitive Transient for 100ns)	V <sub>HS</sub> - 2	-	V
ESD Ratings		Value	Unit
Human Body Model (Tested per JS-001-2017)		2.5	kV
Charged Device Model (Tested per JS-002-2014)		1	kV
Latch-Up (Tested per JESD78E; Class 2, Level A)		100	mA

**CAUTION:** Do not operate at or near the maximum ratings listed for extended periods of time. Exposure to such conditions can adversely impact product reliability and result in failures not covered by warranty.

**Note:**

5. All voltages referenced to VSS unless otherwise specified.

### 2.2 Thermal Information

Package Type	Thermal Resistance (Typical)		Max Power Dissipation at +25°C in Free Air (W) ( <a href="#">Note 10</a> )
	$\theta_{JA}$ (°C/W)	$\theta_{JC}$ (°C/W)	
8 Ld SOIC ( <a href="#">Notes 8, 9</a> )	102	50	1.22
10 Ld TDFN, 8 Ld DFN ( <a href="#">Notes 6, 7</a> )	40	2.5	3.12

**Notes:**

- $\theta_{JA}$  is measured in free air with the component mounted on a high-effective thermal conductivity test board with direct attach features. See [TB379](#).
- For  $\theta_{JC}$ , the case temperature location is the center of the exposed metal pad on the package underside.
- $\theta_{JA}$  is measured with the component mounted on a high-effective thermal conductivity test board in free air. See [TB379](#).
- For  $\theta_{JC}$ , the case temperature location is taken at the package top center.
- Specified at published junction to ambient thermal resistance for a junction temperature of +150°C. See [Note 6](#) for test condition to establish junction to ambient thermal resistance.

Parameter	Minimum	Maximum	Unit
Maximum Junction Temperature	-65	+150	°C
Maximum Storage Temperature Range	-55	+140	°C
Pb-Free Reflow Profile	see <a href="#">TB493</a>		

## 2.3 Recommended Operating Conditions

Parameter (Note 5)	Minimum	Maximum	Units
Supply Voltage, VDD	+6	+18	V
HI, LI, EN Inputs	0	V <sub>DD</sub>	V
PWM, VREF Inputs	0	+5.5	V
Resistor on RDT pin to VSS for Programmable Dead Time	+10	+100	kΩ
Boot Voltage, HB Referenced to HS	V <sub>DD</sub> - 1	+18	V
Bootstrap Voltage, HB	-	+115	V
Continuous Voltage on HS	The greater of [-10 or -(20 - V <sub>DD</sub> )]	+100	V
HS Slew Rate		<50	V/ns
Temperature	-40°C	+125	°C

## 2.4 Electrical Specifications

VDD = HB = EN = 12V; VSS = HS = 0V; HI = LI = 0; VREF = 5V; PWM = 2.5V. No load on LO or HO, unless otherwise specified. **Boldface limits apply across the operating temperature range, -40°C to +125°C.**

Parameters	Symbol	Test Conditions	Min (Note 11)	Typ	Max (Note 11)	Units
<b>Supply Currents (HIP2211)</b>						
V <sub>DD</sub> Quiescent Current	I <sub>DDQ</sub>	HI = LI = 0	-	390	<b>628</b>	μA
V <sub>DD</sub> Operating Current	I <sub>DDO</sub>	f <sub>SW</sub> = 500kHz; HI = LI = 50% square wave to VDD	-	1.5	<b>1.69</b>	mA
HB to HS Quiescent Current	I <sub>HBQ</sub>	HI = 1; LI = 0	-	370	<b>475</b>	μA
HB to HS Operating Current	I <sub>HBO</sub>	f <sub>SW</sub> = 500kHz; HI = LI = 50% square wave to VDD	-	1.4	<b>1.6</b>	mA
HB to V <sub>SS</sub> Current, Operating	I <sub>HBSO</sub>	f <sub>SW</sub> = 500kHz; HI = LI = 50% square wave to VDD; V <sub>HB</sub> = 115V; V <sub>HS</sub> = 100V	-	88	<b>110</b>	μA
HB to V <sub>SS</sub> Leakage Current	I <sub>HBS</sub>	HI = LI = 0; V <sub>HB</sub> = V <sub>HS</sub> = 100V	-	29	<b>47</b>	μA
<b>Supply Currents (HIP2210)</b>						
V <sub>DD</sub> Quiescent Current	I <sub>DDQ</sub>	PWM = 0.5 x VREF; EN = 1; RDT = 1kΩ; 100kΩ	-	455	<b>700</b>	μA
V <sub>DD</sub> Quiescent Current	I <sub>DDQ</sub>	PWM = 0.5 x VREF; EN = 1; RDT = 10kΩ	-	800	<b>1000</b>	μA
V <sub>DD</sub> Operating Current	I <sub>DDO</sub>	f <sub>SW</sub> = 500kHz; PWM = 50% square wave to VREF; RDT = 10kΩ	-	2	<b>2.32</b>	mA
V <sub>DD</sub> Disabled Current	I <sub>DDSD</sub>	EN = 0; RDT = 1kΩ; 100kΩ	-	440	<b>580</b>	μA
V <sub>DD</sub> Disabled Current	I <sub>DDSD</sub>	EN = 0; RDT = 10kΩ	-	780	<b>900</b>	μA
HB to HS Quiescent Current	I <sub>HBQ</sub>	PWM = VREF; EN = 1	-	370	<b>475</b>	μA
HB to HS Operating Current	I <sub>HBO</sub>	f <sub>SW</sub> = 500kHz; PWM = 50% square wave to VREF; RDT = 100kΩ	-	1.7	<b>2</b>	mA
HB to V <sub>SS</sub> Current, Operating	I <sub>HBSO</sub>	f <sub>SW</sub> = 500kHz; PWM = 50% square wave to VREF; V <sub>HB</sub> = 115V; V <sub>HS</sub> = 100V; RDT = 100kΩ	-	95	<b>126</b>	μA
HB to V <sub>SS</sub> Leakage Current	I <sub>HBS</sub>	PWM = 0.5 x VREF; V <sub>HB</sub> = V <sub>HS</sub> = 100V	-	28	<b>52</b>	μA

VDD = HB = EN = 12V; VSS = HS = 0V; HI = LI = 0; VREF = 5V; PWM = 2.5V. No load on LO or HO, unless otherwise specified. **Boldface limits apply across the operating temperature range, -40°C to +125°C. (Continued)**

Parameters	Symbol	Test Conditions	Min (Note 11)	Typ	Max (Note 11)	Units
<b>HI and LI Inputs (HIP2211)</b>						
Low Level Threshold	$V_{IL}$		<b>1.29</b>	1.4	<b>1.47</b>	V
High Level Threshold	$V_{IH}$		<b>1.84</b>	2.1	<b>2.35</b>	V
Input Threshold Hysteresis	$V_{HYS}$		-	0.7	-	V
Input Pull-Down Resistance	$R_{IN}$	HI = LI = VDD; Resistance to VSS	-	95	-	k $\Omega$
Minimum Input Pulse Width for Response at Output	$T_{MIN}$	No load on HO and LO; Output drives to rail	-	10	-	ns
<b>Tri-Level PWM Input (HIP2210)</b>						
Middle to High Level Threshold	$V_{PWMHR}$	VREF = 2.7V and 5.5V	<b>63.6</b>	66	<b>69.7</b>	% VREF
High to Middle Level Threshold	$V_{PWMHF}$	VREF = 2.7V and 5.5V	<b>53.7</b>	56	<b>59.6</b>	% VREF
High/Middle Level Hysteresis		VREF = 2.7V and 5.5V	-	10	-	% VREF
Low to Middle Level Threshold	$V_{PWMLR}$	VREF = 2.7V and 5.5V	<b>30.3</b>	33	<b>36.3</b>	% VREF
Middle to Low Level Threshold	$V_{PWMLF}$	VREF = 2.7V and 5.5V	<b>19.5</b>	23	<b>26.3</b>	% VREF
Low/Middle Level Hysteresis		VREF = 2.7V and 5.5V	-	10	-	% VREF
PWM Open Circuit Voltage	$V_{FLOAT}$	PWM pin floating; VREF = 2.7V and 5.5V	<b>48</b>	50	<b>52</b>	% VREF
Logic High Input Current	$I_{PWMH}$	PWM = 3V; VREF = 3V; Sourcing	-	16	-	$\mu$ A
Logic Low Input Current	$I_{PWML}$	PWM = 0V; VREF = 3V; Sinking	-	16	-	$\mu$ A
PWM Pull-Up Resistance	$R_{UP}$	To VREF	-	180	-	k $\Omega$
PWM Pull-Down Resistance	$R_{DOWN}$	To VSS	-	180	-	k $\Omega$
Minimum Input Pulse Width for Response at Output	$T_{MIN}$	No load on HO and LO; Output drives to rail	-	20	-	ns
<b>VREF Input (HIP2210)</b>						
VREF Enabled Rising Threshold	$V_{VREF\_R}$	PWM = 0; EN = 1; RDT = 1k $\Omega$	-	2.55	<b>2.7</b>	V
VREF Disabled Hysteresis	$V_{VREF\_H}$	PWM = 0; EN = 1; RDT = 1k $\Omega$	-	0.18	-	V
VREF Enable Delay	$t_{VREF\_R}$	PWM = 0; EN = 1; RDT = 1k $\Omega$	-	175	-	ns
VREF Disabled Delay	$t_{VREF\_F}$	PWM = 0; EN = 1; RDT = 1k $\Omega$	-	110	-	ns
VREF Pull-Down Resistance to VSS	$R_{VREF}$	VREF = 3V; PWM = Float	-	90	-	k $\Omega$
<b>EN Input (HIP2210)</b>						
Low-Level Threshold	$V_{ENL}$		<b>1.26</b>	1.38	<b>1.47</b>	V
High-Level Threshold	$V_{ENH}$		<b>1.84</b>	2.1	<b>2.31</b>	V
Input Threshold Hysteresis	$V_{HYS}$		-	0.72	-	V
Input Pull-Down Resistance	$R_{EN}$	$V_{EN} = VDD$ ; To VSS	-	90	-	k $\Omega$
EN High Propagation Delay	$t_{ENH}$	RDT = 1k $\Omega$ ; PWM = 0	<b>450</b>	800	<b>1100</b>	ns
EN Low Propagation Delay	$t_{ENL}$	RDT = 1k $\Omega$ ; PWM = 0	-	115	<b>150</b>	ns
<b>Undervoltage Protection</b>						
VDD Rising UVLO Threshold	VDDR		<b>5.3</b>	5.6	<b>5.9</b>	V
VDD Falling UVLO Threshold	VDDF		<b>4.75</b>	5.1	<b>5.35</b>	V
VDD Threshold Hysteresis	VDDH		-	0.5	-	V

VDD = HB = EN = 12V; VSS = HS = 0V; HI = LI = 0; VREF = 5V; PWM = 2.5V. No load on LO or HO, unless otherwise specified. **Boldface limits apply across the operating temperature range, -40°C to +125°C. (Continued)**

Parameters	Symbol	Test Conditions	Min (Note 11)	Typ	Max (Note 11)	Units
V <sub>DD</sub> Rising UVLO Delay		Characterization only. No limits.	-	1	-	μs
V <sub>DD</sub> Falling UVLO Delay		Characterization only. No limits.	-	2	-	μs
V <sub>HB</sub> Rising Threshold	VHBR		<b>4.8</b>	5.1	<b>5.4</b>	V
V <sub>HB</sub> Falling Threshold	VHBF		<b>4.25</b>	4.6	<b>4.85</b>	V
V <sub>HB</sub> Threshold Hysteresis	VHBH		-	0.5	-	V
V <sub>HB</sub> Rising UVLO Delay		Characterization only. No limits.	-	10	-	μs
V <sub>HB</sub> Falling UVLO Delay		Characterization only. No limits.	-	12	-	μs
<b>Bootstrap Diode</b>						
Low Current Forward Voltage	V <sub>FL</sub>	I <sub>VDD-HB</sub> = 100μA	-	0.65	<b>0.85</b>	V
High Current Forward Voltage	V <sub>FH</sub>	I <sub>VDD-HB</sub> = 100mA	-	0.85	<b>1</b>	V
Dynamic Resistance	R <sub>D</sub>	R <sub>D</sub> = ΔV <sub>D</sub> /ΔI <sub>VDD-HB</sub> I <sub>VDD-HB</sub> = 80mA and 100mA	-	0.5	<b>0.9</b>	Ω
Reverse Bias Leakage	I <sub>R</sub>	V <sub>HB</sub> = V <sub>HS</sub> = 100V; V <sub>DD</sub> = 0V	-	0.11	-	μA
Reverse Recovery Time	t <sub>RR</sub>	100mA forward to 100V reverse	-	50	-	ns
<b>LO Gate Driver</b>						
Low-Level Output Voltage	V <sub>OL_LO</sub>	I <sub>LO</sub> = 100mA sink	-	0.1	<b>0.17</b>	V
High-Level Output Voltage	V <sub>OH_LO</sub>	I <sub>LO</sub> = 100mA source V <sub>OH_LO</sub> = V <sub>DD</sub> - V <sub>LO</sub>	-	0.16	<b>0.27</b>	V
Peak Pull-Up Source Current	I <sub>OH_LO</sub>	V <sub>LO</sub> = 0V; Limits are internal specifications only	-	3	-	A
Peak Pull-Down Sink Current	I <sub>OL_LO</sub>	V <sub>LO</sub> = 12V; Limits are internal specifications only	-	4	-	A
LO Pin Pull-Down Resistance	R <sub>LO</sub>	V <sub>DD</sub> = 0V; LO = 100mV; To VSS	-	140	-	kΩ
<b>HO Gate Driver</b>						
Low-Level Output Voltage	V <sub>OL_HO</sub>	I <sub>HO</sub> = 100mA sink	-	0.1	<b>0.17</b>	V
High-Level Output Voltage	V <sub>OH_HO</sub>	I <sub>HO</sub> = 100mA source V <sub>OH_HO</sub> = V <sub>HB</sub> - V <sub>HO</sub>	-	0.16	<b>0.27</b>	V
Peak Pull-Up Current	I <sub>OH_HO</sub>	V <sub>HO</sub> = 0V; Limits are internal specifications only.	-	3	-	A
Peak Pull-Down Current	I <sub>OL_HO</sub>	V <sub>HO</sub> = V <sub>HB</sub> ; Limits are internal specifications only.	-	4	-	A
HO Pin Pull-Down Resistance	R <sub>HO</sub>	HB - HS = 0V; HO = 100mV; To HS	-	450	-	kΩ

## 2.5 Switching Specifications

VDD = HB = 12V; VSS = HS = 0V; HI = LI = 0V to 5V; PWM = 0V to V<sub>REF</sub>; RDT = 1kΩ, 10kΩ, or 100kΩ. No load on LO or HO, unless otherwise specified. **Boldface limits apply across the operating temperature range, -40°C to +125°C.**

Parameters	Symbol	Test Conditions	Min (Note 11)	Typ	Max (Note 11)	Units
<b>Propagation Delays (HIP2211)</b>						
LO Turn-Off Propagation Delay	t <sub>PDLI_F</sub>	LI = 1 to 0; VDD = 12V	-	15	<b>30</b>	ns
		LI = 1 to 0; VDD = 6V	-	15	<b>30</b>	ns
LO Turn-On Propagation Delay	t <sub>PDLI_R</sub>	LI = 0 to 1; VDD = 12V	-	15	<b>30</b>	ns
		LI = 0 to 1; VDD = 6V	-	15	<b>30</b>	ns

VDD = HB = 12V; VSS = HS = 0V; HI = LI = 0V to 5V; PWM = 0V to V<sub>REF</sub>; RDT = 1kΩ, 10kΩ, or 100kΩ. No load on LO or HO, unless otherwise specified. **Boldface limits apply across the operating temperature range, -40°C to +125°C.** (Continued)

Parameters	Symbol	Test Conditions	Min (Note 11)	Typ	Max (Note 11)	Units
HO Turn-Off Propagation Delay	$t_{PDHI\_F}$	HI = 1 to 0; HB - HS = 12V	-	15	<b>30</b>	ns
		HI = 1 to 0; HB - HS = 6V	-	15	<b>30</b>	ns
HO Turn-On Propagation Delay	$t_{PDHI\_R}$	HI = 0 to 1; HB - HS = 12V	-	15	<b>30</b>	ns
		HI = 0 to 1; HB - HS = 6V	-	15	<b>30</b>	ns
Propagation Delay Matching	$t_{MATCH\_LH}$	LI = 1 to 0; HI = 0 to 1 LO falling to HO rising	<b>-6</b>	1.5	<b>6</b>	ns
	$t_{MATCH\_HL}$	HI = 1 to 0; LI = 0 to 1 HO falling to LO rising	<b>-6</b>	1.5	<b>6</b>	ns
<b>Propagation Delays (HIP2210)</b>						
HO Turn-Off Propagation Delay	$t_{PDHO}$	PWM falling to HO falling; VREF = 5V; RDT = 1kΩ; VDD = HB - HS = 12V	-	30	<b>40</b>	ns
		PWM falling to HO falling; VREF = 5V; RDT = 1kΩ; VDD = HB - HS = 6V	-	30	<b>40</b>	ns
LO Turn-Off Propagation Delay	$t_{PDLO}$	PWM rising to LO falling; VREF = 5V; RDT = 1kΩ; VDD = HB - HS = 12V	-	30	<b>43</b>	ns
		PWM rising to LO falling; VREF = 5V; RDT = 1kΩ; VDD = HB - HS = 6V	-	30	<b>43</b>	ns
Turn-Off Propagation Delay Matching	$t_{PDMATCH}$	$t_{PDHO} - t_{PDLO}$ ; VREF = 5V; RDT = 1kΩ; VDD = HB - HS = 12V	-10	2	<b>10</b>	ns
		$t_{PDHO} - t_{PDLO}$ ; VREF = 5V; RDT = 1kΩ; VDD = HB - HS = 6V	-10	2	<b>10</b>	ns
PWM High to Mid State to HO Off Propagation Delay	$t_{PD\_PWM\_HM}$	VREF = 5V; RDT = 1kΩ; PWM 5V to 2.5V	-	70	<b>90</b>	ns
PWM Mid to High State to HO On Propagation Delay	$t_{PD\_PWM\_MH}$	VREF = 5V; RDT = 1kΩ; PWM 2.5V to 5V	-	60	<b>82</b>	ns
PWM Low to Mid state to LO Off Propagation Delay	$t_{PD\_PWM\_LM}$	VREF = 5V; RDT = 1kΩ; PWM 0V to 2.5V	-	70	<b>87</b>	ns
PWM Mid to Low State to LO On Propagation Delay	$t_{PD\_PWM\_ML}$	VREF = 5V; RDT = 1kΩ; PWM 2.5V to 0V	-	60	<b>79</b>	ns
<b>RDT Programmable Dead Time Delays (HIP2210)</b>						
Minimum Dead Time Delay (Note 12) HO Falling to LO Rising	$t_{DTHL\_MIN}$	RDT = 1kΩ, PWM high to low	<b>5</b>	11	<b>18</b>	ns
Minimum Dead Time Delay (Note 12) LO Falling to HO Rising	$t_{DTLH\_MIN}$	RDT = 1kΩ, PWM low to high	<b>5</b>	11	<b>18</b>	ns
Low Range Delay (Note 12) HO Falling to LO Rising	$t_{DTHL\_LOW}$	RDT = 10kΩ, PWM high to low	<b>30</b>	36	<b>45</b>	ns
Low Range Delay (Note 12) LO Falling to HO Rising	$t_{DTLH\_LOW}$	RDT = 10kΩ, PWM low to high	<b>30</b>	36	<b>45</b>	ns
High Range Delay (Note 12) HO Falling to LO Rising	$t_{DTHL\_HIGH}$	RDT = 100kΩ, PWM high to low	<b>300</b>	360	<b>425</b>	ns
High Range Delay (Note 12) LO Falling to HO Rising	$t_{DTLH\_HIGH}$	RDT = 100kΩ, PWM low to high	<b>300</b>	360	<b>425</b>	ns
Maximum Dead Time Delay (Note 12) HO Falling to LO Rising	$t_{DTHL\_MAX}$	RDT = 200kΩ, PWM high to low	-	715	-	ns

VDD = HB = 12V; VSS = HS = 0V; HI = LI = 0V to 5V; PWM = 0V to V<sub>REF</sub>; RDT = 1kΩ, 10kΩ, or 100kΩ. No load on LO or HO, unless otherwise specified. **Boldface limits apply across the operating temperature range, -40°C to +125°C. (Continued)**

Parameters	Symbol	Test Conditions	Min (Note 11)	Typ	Max (Note 11)	Units
Maximum Dead Time Delay (Note 12) LO Falling to HO Rising	t <sub>DTLH_MAX</sub>	RDT = 200kΩ, PWM low to high	-	745	-	ns
Dead Time Delay Matching (Note 12)	t <sub>MATCH_MIN</sub>	RDT = 1kΩ	-	2.5	-	ns
	t <sub>MATCH_LOW</sub>	RDT = 10kΩ	-	2.5	-	ns
	t <sub>MATCH_HIGH</sub>	RDT = 100kΩ	<b>-30</b>	-	<b>30</b>	ns
	t <sub>MATCH_HIGH</sub>	RDT = 200kΩ	-	30	-	ns
<b>Rise and Fall Times</b>						
LO/HO Output Rise Time	t <sub>RISE1</sub>	C <sub>LOAD</sub> = 1nF; VDD = HB - HS = 12V 10% to 90%	-	20	-	ns
		C <sub>LOAD</sub> = 1nF; VDD = HB - HS = 6V 10% to 90%	-	20	-	ns
	t <sub>RISE2</sub>	C <sub>LOAD</sub> = 100nF; VDD = HB - HS = 12V 10% to 90%	-	435	<b>1010</b>	ns
		C <sub>LOAD</sub> = 100nF; VDD = HB - HS = 6V 10% to 90%	-	355	<b>1010</b>	ns
LO/HO Output Fall Time	t <sub>FALL1</sub>	C <sub>LOAD</sub> = 1nF; VDD = HB - HS = 12V 90% to 10%	-	20	-	ns
		C <sub>LOAD</sub> = 1nF; VDD = HB - HS = 6V 90% to 10%	-	20	-	ns
	t <sub>FALL2</sub>	C <sub>LOAD</sub> = 100nF; VDD = HB - HS = 12V 90% to 10%	-	365	<b>790</b>	ns
		C <sub>LOAD</sub> = 100nF; VDD = HB - HS = 6V 90% to 10%	-	290	<b>790</b>	ns

**Notes:**

- Compliance to datasheet limits is assured by one or more methods: production test, characterization, and/or design.
- Dead Time is defined as the time between LO falling to HO rising or between HO falling to LO rising. See [Timing Diagrams](#) for measurement specification.

## 2.6 Timing Diagrams

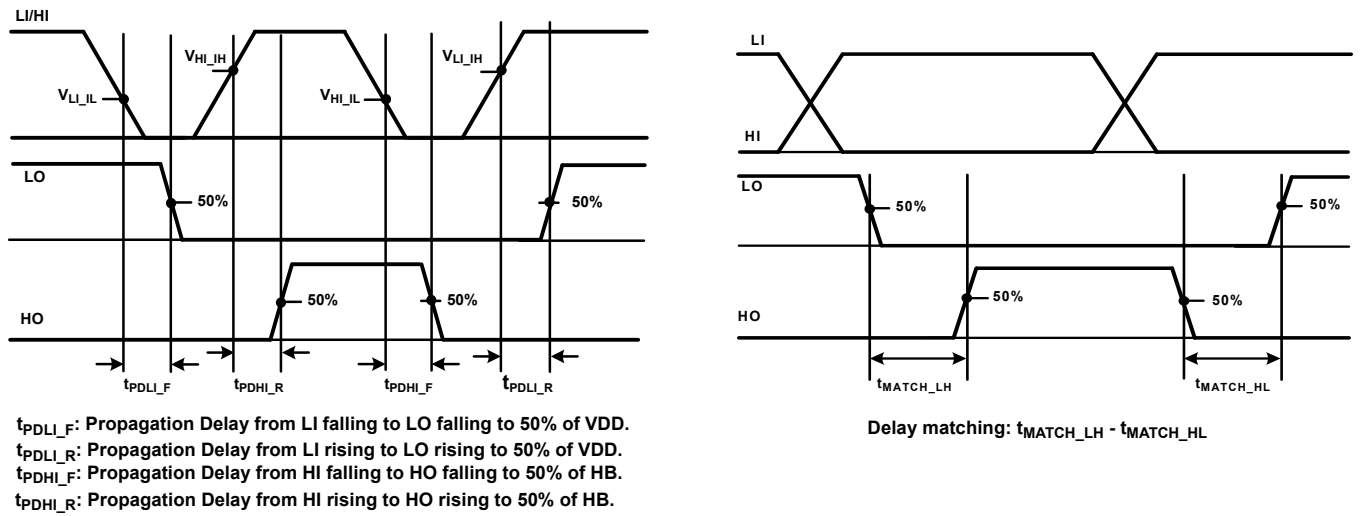

Figure 5. HIP2211 Propagation Delay Timing Diagram

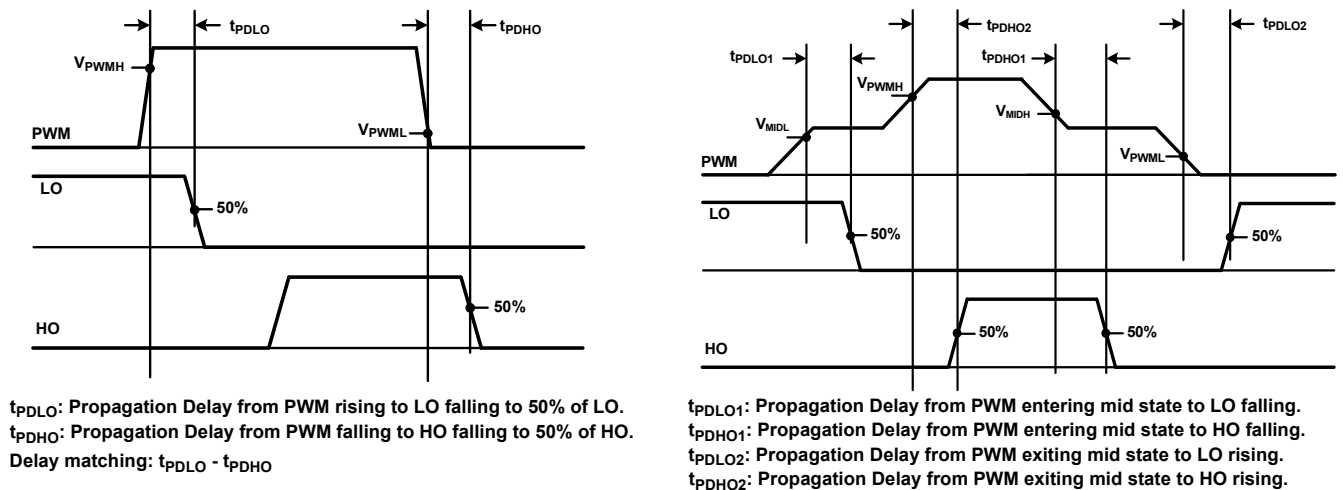

Figure 6. HIP2210 Propagation Delay Timing Diagram

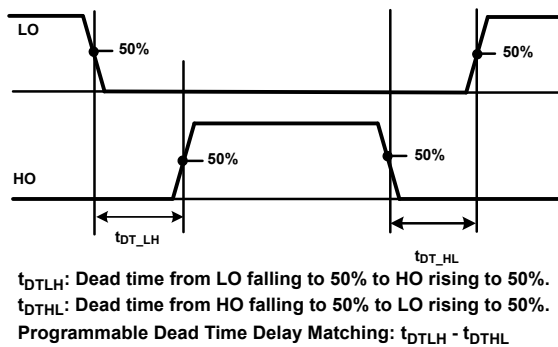

Figure 7. HIP2210 Programmable Dead Time Delay Timing Diagram

### 3. Typical Performance Curves

Unless otherwise specified, operating conditions at: T = +25°C; VDD = EN = 12V; VSS = HS = 0V; Capacitor from HB to HS pin C<sub>BOOT</sub> = 0.22µF; 100kΩ load on LO to VSS and HO to HS.

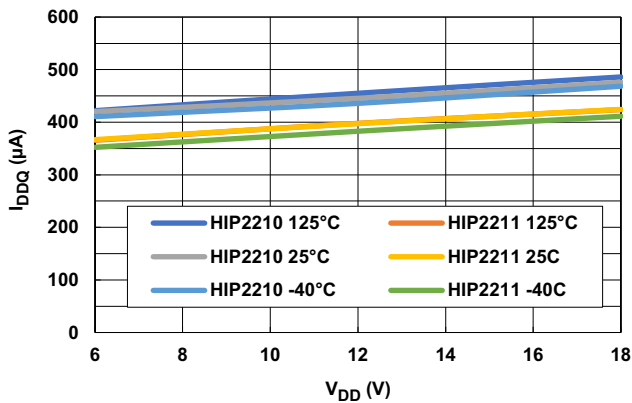

Figure 8. I<sub>DD</sub> Quiescent Current (RDT = 1k) vs Temperature vs V<sub>DD</sub>

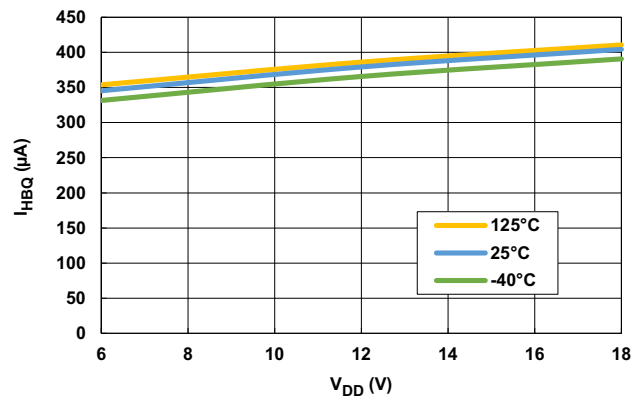

Figure 9. I<sub>HB</sub> Quiescent Current vs Temperature vs V<sub>DD</sub>

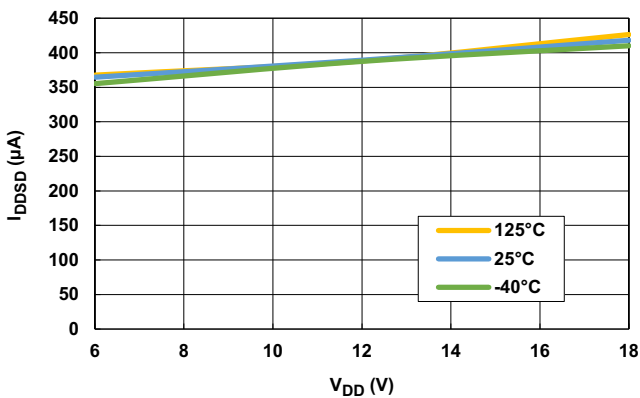

Figure 10. I<sub>DD</sub> Disabled Current (RDT = 1k) vs Temperature vs V<sub>DD</sub>

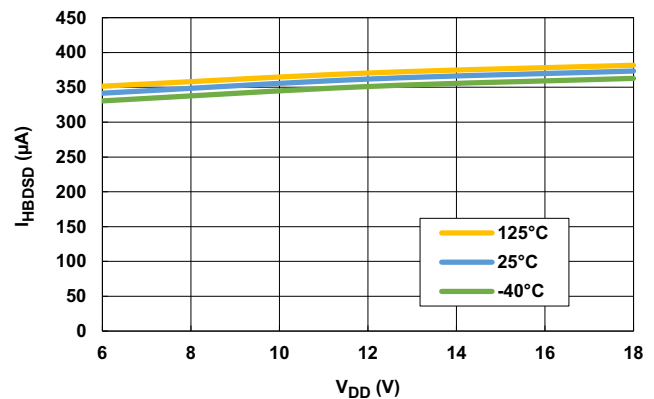

Figure 11. I<sub>HB</sub> Disabled Current (RDT = 1k) vs Temperature vs V<sub>DD</sub>

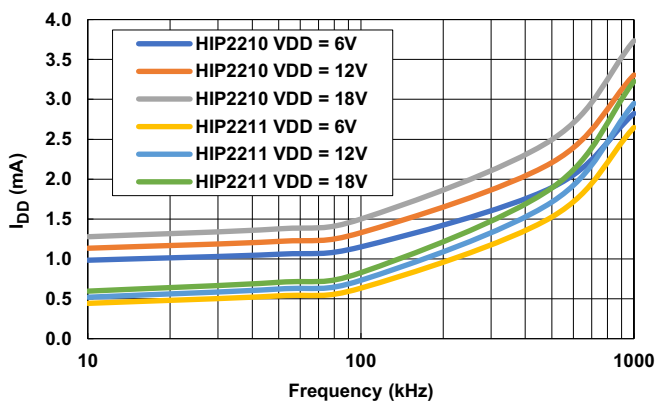

Figure 12. I<sub>DD</sub> Operating Current (RDT = 10k) vs Frequency vs V<sub>DD</sub>

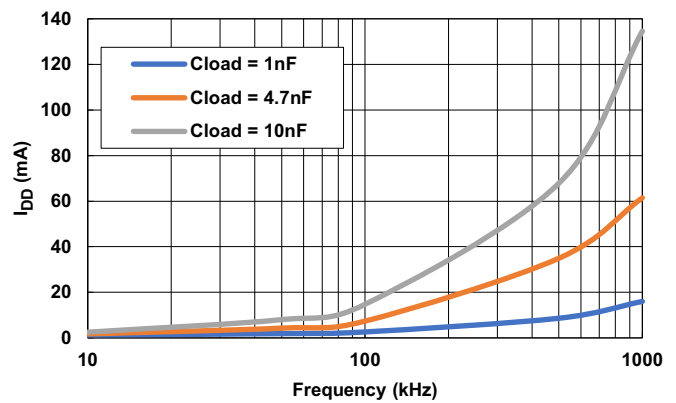

Figure 13. I<sub>DD</sub> Operating Current (RDT = 10k) vs Frequency vs Capacitance Load

Unless otherwise specified, operating conditions at: T = +25°C; VDD = EN = 12V; VSS = HS = 0V; Capacitor from HB to HS pin  
 CBOOT = 0.22µF; 100kΩ load on LO to VSS and HO to HS. (Continued)

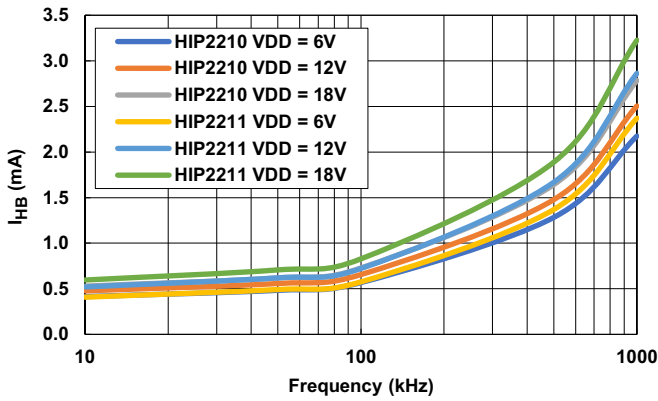

Figure 14. I<sub>HB</sub> Operating Current (RDT = 10k) vs Frequency vs V<sub>DD</sub>

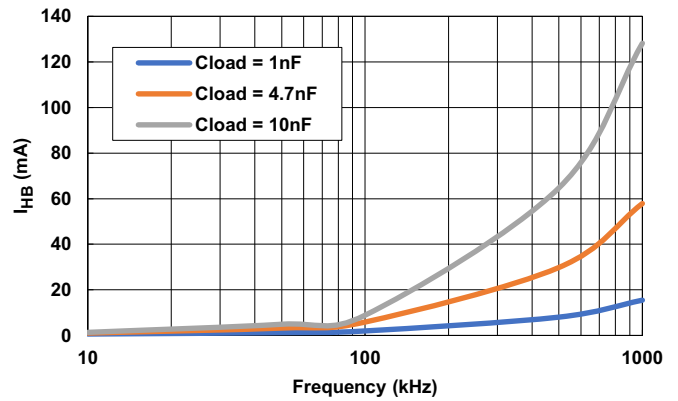

Figure 15. I<sub>HB</sub> Operating Current (RDT = 10k) vs Frequency vs Capacitance Load

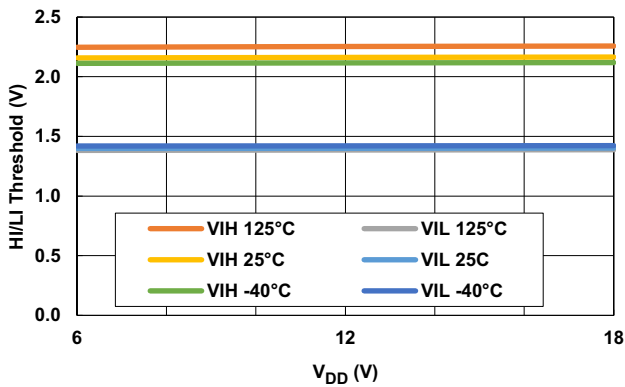

Figure 16. HI/LI Threshold Levels vs Temperature vs V<sub>DD</sub>

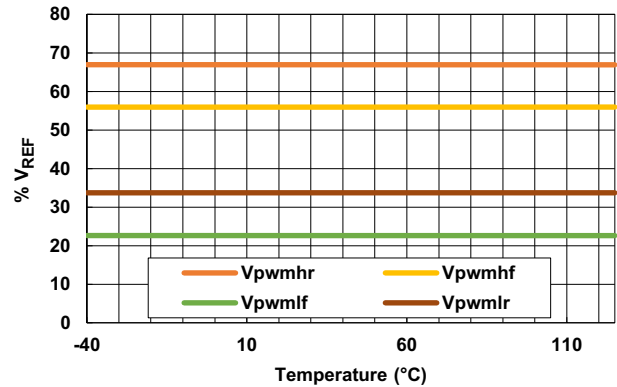

Figure 17. PWM Threshold Levels vs Temperature

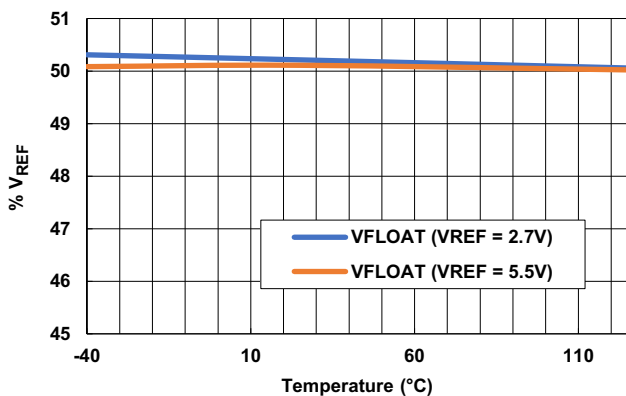

Figure 18. PWM Floating Pin Voltage vs Temperature vs V<sub>DD</sub>

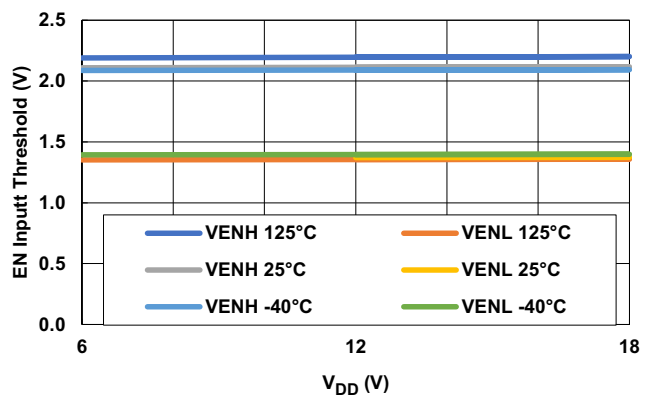

Figure 19. EN Input Threshold vs Temperature vs V<sub>DD</sub>

Unless otherwise specified, operating conditions at: T = +25°C; VDD = EN = 12V; VSS = HS = 0V; Capacitor from HB to HS pin  
 C<sub>BOOT</sub> = 0.22µF; 100kΩ load on LO to VSS and HO to HS. **(Continued)**

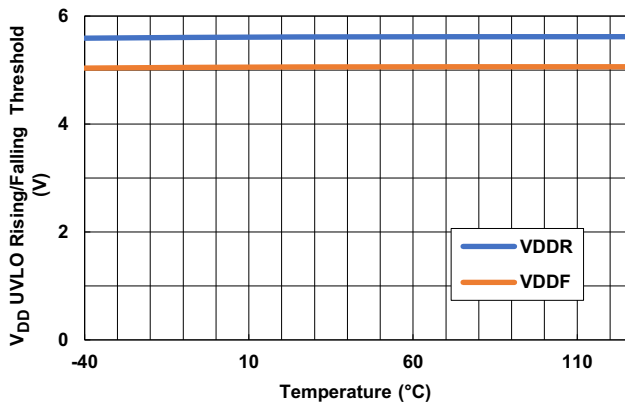

Figure 20. VDD UVLO Rising and Falling Threshold vs Temperature

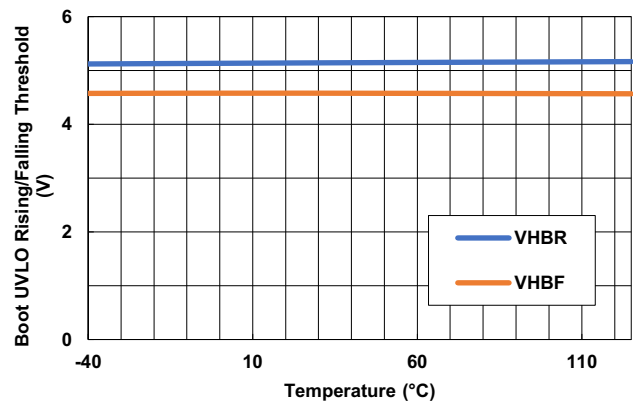

Figure 21. HB UVLO Rising and Falling Threshold vs Temperature

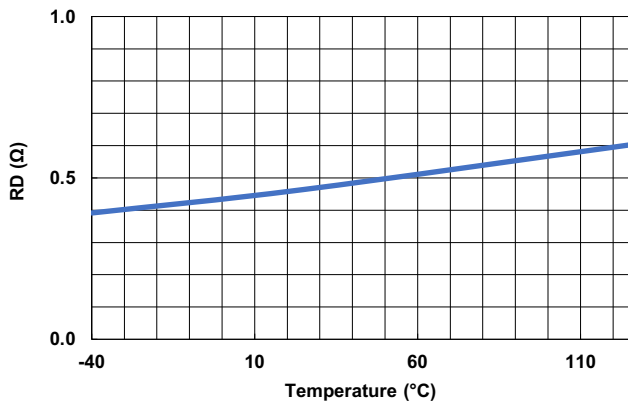

Figure 22. Boot Diode Impedance vs Temperature

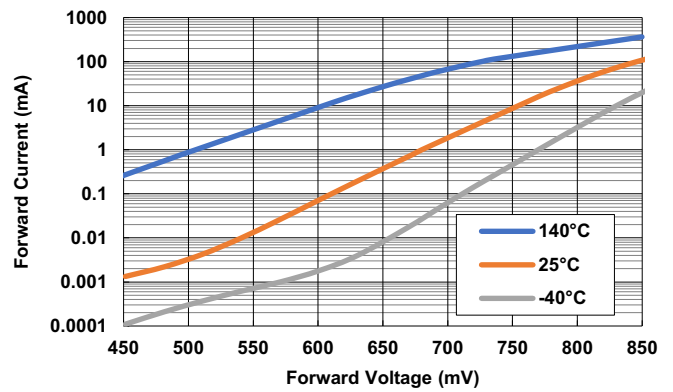

Figure 23. Boot Diode I-V Curve vs Temperature

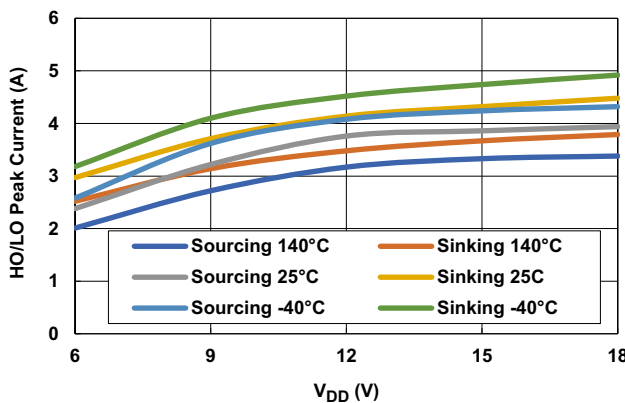

Figure 24. HO/LO Output Current (100nF load) vs Temperature vs Supply Voltage

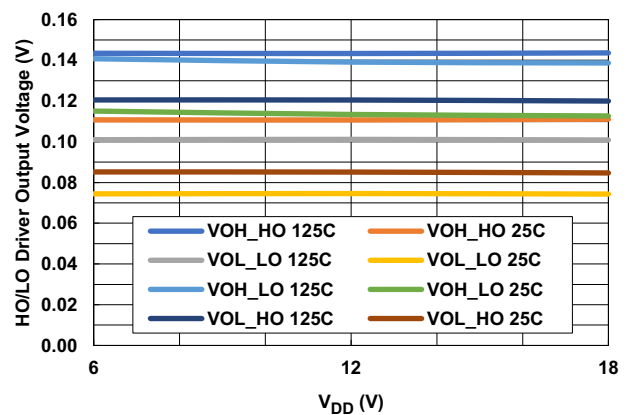

Figure 25. HO/LO Output Voltage vs Temperature vs Supply Voltage (For Loading See EC Table)

Unless otherwise specified, operating conditions at: T = +25°C; VDD = EN = 12V; VSS = HS = 0V; Capacitor from HB to HS pin  
 C<sub>BOOT</sub> = 0.22µF; 100kΩ load on LO to VSS and HO to HS. (Continued)

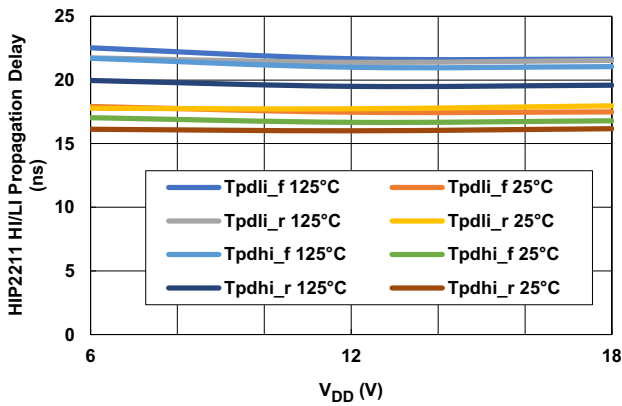

Figure 26. HI/LI Propagation Delay vs Temperature vs V<sub>DD</sub>

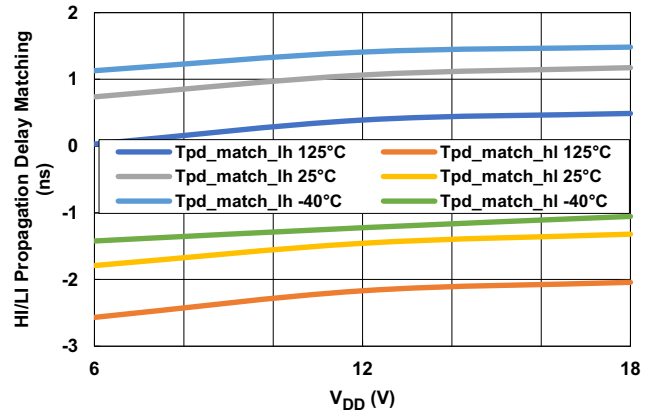

Figure 27. HI/LI Propagation Delay Matching vs Temperature vs V<sub>DD</sub>

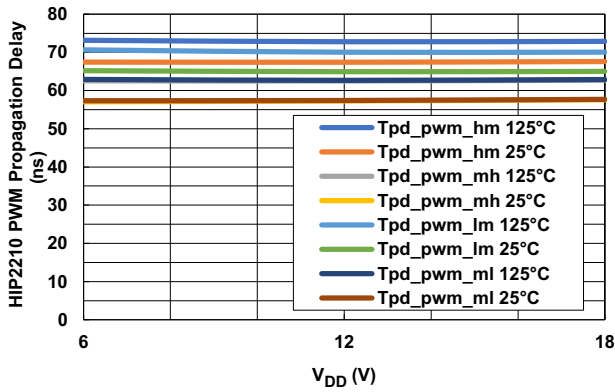

Figure 28. PWM Propagation Delay vs Temperature vs V<sub>DD</sub>

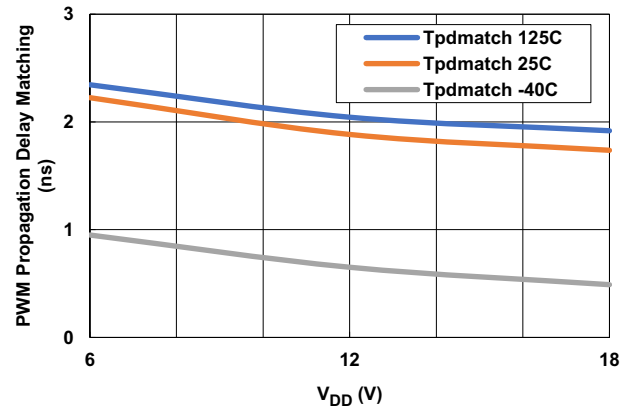

Figure 29. PWM Propagation Delay Matching vs Temperature vs V<sub>DD</sub>

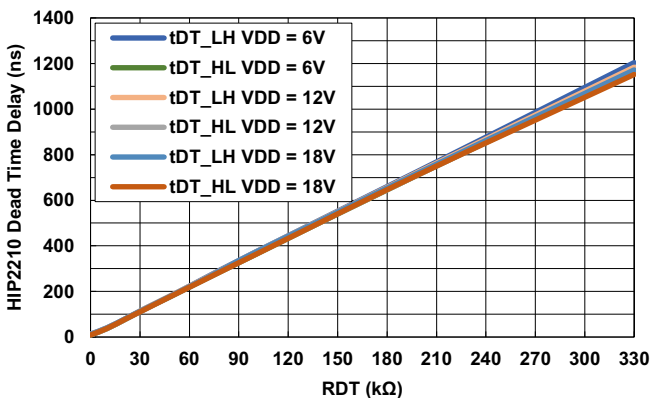

Figure 30. Dead Time Delay (25°C) vs RDT Resistor vs V<sub>DD</sub>

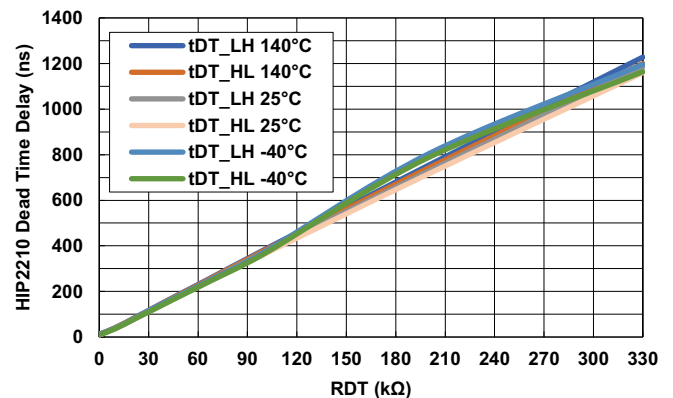

Figure 31. Dead Time Delay (VDD = 12V) vs RDT Resistor vs Temperature

---

## 4. Functional Description

### 4.1 Gate Drive for NMOS Half-Bridge

The HIP2210 and HIP2211 are NMOS FET drivers for half-bridge, full-bridge, two-switch forward, active clamp, or synchronous buck configurations. In half-bridge configurations, the gate of the low-side FET requires a ground referenced signal above the gate threshold voltage to switch on and off. The high-side FET source terminal is connected to the drain of the low-side FET and is called the Phase or Switch node. When the high-side FET is on, its source terminal is at the high voltage supply. The gate drive of the high-side FET requires a floating bootstrap supply to properly drive the high-side FET gate voltage relative to its source terminal. A bootstrap circuit is implemented on these drivers to properly switch the high-side and low-side NMOS FETs.

### 4.2 Functional Overview

The HIP2210 and HIP2211 drivers are designed to switch NMOS FETs in up to 100V half-bridge configurations. The drivers feature strong 3A sourcing and 4A sinking output drive capability and fast 15ns propagation delay times to switch low  $r_{DS(ON)}$  NFETs for up to 1MHz applications. With an integrated bootstrap diode, the floating high-side bias requires only an external bootstrap capacitor to properly drive the high-side FET.

The drivers have integrated UVLO on both the VDD and Boot supply to prevent low gate voltage drive to the NFETs. The HIP2210 and HIP2211 can operate across a wide VDD voltage range of 6V to 18V.

The HIP2211 has 3.3V CMOS compatible HI and LI inputs to control the high-side and low-side driver outputs, respectively.

The HIP2210 features a single tri-level PWM input to control the high-side and low-side drivers. The tri-level thresholds are set by an external VREF pin, which allows PWM control from 2.7V to 5.5V logic supply voltages. When PWM is high, the high-side driver is sourcing and the low-side driver is sinking. When PWM is low, the low-side driver is sourcing and the high-side driver is sinking. When PWM is at mid-level, both driver outputs are sinking to put the half-bridge in a high impedance state. The HIP2210 also has an EN pin to enable the input logic control, or disable it and place the half-bridge in high impedance state. This EN pin feature is useful to prevent false switching of the NFETs during controller start-up. See [“Applications Information” on page 18](#) for more information about the PWM input control.

The HIP2210 controls dead time with an adjustable dead time delay pin (RDT). A resistor to ground sets a dead time delay of the rising edge of the driver output. See [Applications Information](#) for more information about setting the adjustable dead time delay.

## 5. Applications Information

### 5.1 HI/LI Input Control (HIP2211 Only)

The HIP2211 HI and LI logic inputs control the high-side driver and low-side driver, respectively. The inputs are 3.3V logic level compatible and VDD voltage tolerant. Typical 100kΩ pull-down resistors internally bias the HI and LI inputs logic low when they are left floating. The HIP2211 HI and LI inputs do not have any logic input lockout protection. If HI and LI are logic high, both output drivers are turned on sourcing and can cause a shoot-through condition on the half-bridge MOSFETs. It is critical to provide adequate dead time on the controller side when operating the HI and LI inputs in half-bridge applications.

### 5.2 PWM Input Control (HIP2210 Only)

The HIP2210 PWM input is a tri-level logic pin. The following are the three levels:

- Low-level: Turns on the lower gate drive
- High-level: Turns on the upper gate drive
- Mid-level: Turns both gate drivers off for high impedance of the half-bridge

By design, the PWM input prevents a controller from turning both drivers on, providing shoot-through protection against faulted input logic that can occur from a two input driver inadvertently turning both drivers on. PWM logic thresholds are referenced to the VREF pin and function from 2.7V to 5.5V. Typical 180kΩ internal resistors on the PWM pin bias to the mid-level of 50% VREF when there is no external PWM signal, turning both sink drivers on and setting the half-bridge to high impedance. The PWM input is tolerant up to 5.5V regardless of the VREF voltage.

### 5.3 VREF Input (HIP2210 Only)

The VREF input sets the PWM input threshold levels. The valid VREF voltage range is 2.7V to 5.5V. If VREF is below its UVLO threshold, driver outputs do not respond to PWM inputs and both output sink drivers turn on, setting the half-bridge to high impedance. An internal pull-down impedance of 100kΩ pulls VREF below the UVLO threshold when the pin is floating.

### 5.4 EN Pin (HIP2210 Only)

When EN pin is logic high, driver outputs respond to PWM inputs. When logic low, driver outputs do not respond to PWM inputs and both output sink drivers turn on, setting the half-bridge to high impedance. An internal pull-down impedance of 100kΩ pulls EN low when it is floating. The EN input is 3.3V logic level compatible and VDD voltage tolerant.

### 5.5 Power Sequencing HIP2210

Renesas recommends using the HIP2210 by tying the EN pin to an external MCU logic I/O for proper power sequencing control.

The proper power turn-on sequence is:

1. VDD
2. VREF
3. EN pin high to enable the driver

The proper power turn-off sequence is:

1. EN pin low to disable the driver
2. VREF
3. VDD

In applications where you prefer to tie the EN pin to VDD, you should understand there can be unintended turn-on transitions on LO and HO when VREF is rising or falling with EN logic high, depending on the PWM pin voltage to VREF. With the driver enabled and when VREF is rising or falling, the PWM tri-level logic input thresholds are

dependent on the transitioning VREF voltage. The PWM open-circuit voltage is referenced to 50% of the VREF voltage. The high impedance voltage divider resistors on the PWM pin coupled with the internal pin capacitance form an RC circuit. During the transient turn-on and turn-off of VREF, the PWM pin open-circuit floating voltage rises to (and falls from) 50% of VREF with an RC time constant delay relative to VREF voltage. Depending on the dv/dt of VREF, the PWM open-circuit floating voltage can lag VREF. When PWM lags behind VREF, the PWM comparators can see logic low on VREF turn-on (and therefore LO turns on) and see logic high on VREF turn-off (and therefore HO turns on) until the PWM voltage falls into the mid-level logic window or VREF hits its UVLO threshold. Although the HO/LO transitions in response to VREF ON and OFF do not violate driver operation or produce bridge shoot through, it is not a desired transient response.

Therefore, the recommended operation of HIP2210 is to externally control the EN pin logic input such that VDD and VREF voltages are stabilized before enabling the driver or the driver is disabled first before turning off VDD and VREF. The VREF pin can also be tied to the bias voltage for the PWM output of the controlling MCU.

For EN = VDD applications, several options can be considered to mitigate the potential issue:

- External pull-up and pull-down resistors (such as 22kΩ) on the PWM pin to reduce the overall resistance and the lag of the PWM voltage behind VREF
- Slower rise/fall time (1-2μs) on VREF to allow the PWM floating pin to track VREF

## 5.6 Selecting the Boot Capacitor Value

To provide the proper gate drive to the high-side FET, the high-side driver bias on the HIP2210 and HIP2211 is handled with a bootstrap capacitor across the HB and HS pins. The boot capacitor is recharged whenever the HS pin voltage goes low and forward biases the boot diode across VDD to HB. Select the boot capacitor based on the total  $Q_{GS}$  of the high-side NMOS FETs, switching frequency, VDD supply, and the total boot impedance, including the dynamic resistance of the boot diode. Connect the boot capacitor close to the HIP2210/HIP2211 HB and HS pins. A low ESL, high-frequency X7R or better ceramic capacitor is recommended.

The boot capacitor value is chosen not only to supply the internal bias current of the high-side driver but also more significantly, to provide the gate charge of the high-side driven NMOS FET without causing the boot voltage to sag excessively. To ensure the proper value of the bootstrap capacitor is selected, the following guideline provides equations for calculating the boot capacitance needed.

- $V_{DD}$  = Driver bias charging supply
- $\Delta V_{BOOT}$  = Maximum allowable voltage dip to ensure proper function; generally 500mV
- $V_{HB} = V_{DD} - 0.7V = V_{HO}$  = Boot voltage and high-side driver bias voltage, referenced to HS
- $t_{ON}$  = Longest on-time of the high-side; for simplicity assume the entire switching period  $t_{ON} = 1/f_{SW}$
- $Q_{GS\_MAX}$  = Maximum gate charge, from NMOS FET datasheet
- $I_{GS\_LKG}$  = Maximum NMOS FET gate-source leakage current, from NMOS FET datasheet
- $R_{GS}$  = Minimum gate-source discharge resistance; usually not less than 10kΩ
- $I_{HBQ}$  = Boot quiescent current with HI = 1 or PWM = 1

The minimum  $C_{BOOT}$  capacitance required to ensure proper functionality becomes dependent on the total charge required during the on state of the high side when the  $C_{BOOT}$  is not charging, along with the allowable change in voltage of the boot.

[Equation 1](#) calculates the total charge required for one switching cycle of the high-side NMOS FET.

$$(EQ. 1) \quad Q_{TOTAL} = Q_{GS\_MAX} + \left( I_{GS\_LKG} + I_{HBQ} + \frac{V_{HO}}{R_{GS}} \right) \times t_{ON}$$

[Equation 2](#) calculates the boot capacitor needed to support the total charge and allowable boot voltage dip requirements:

$$(EQ. 2) \quad C_{BOOT} = \frac{Q_{TOTAL}}{\Delta V_{BOOT}}$$

## 5.7 VDD Decoupling Capacitor

For VDD decoupling, Renesas recommends selecting a capacitor that is at least 10x the value of the boot capacitor. In addition, place a low ESL, high-frequency, X7R or better ceramic capacitor of 1nF to 10nF close to the HIP2210/HIP2211 VDD and VSS pins for high-frequency decoupling.

## 5.8 RDT and Dead Time Delay (HIP2210 Only)

The PWM function of the HIP2210 inherently prevents driver input shoot-through conditions by allowing only one driver that is sourcing output to be active at one time. However, because NMOS FET gate-source capacitance causes FET turn-on/off times to be delayed, it is necessary to have some extra dead time at the driver outputs to prevent shoot-through conditions. The HIP2210 implements programmable dead time through the RDT pin function.

A resistor on the RDT pin to VSS sets the HIP2210 adjustable dead time delay. The delay is between the following:

- The falling edge of the LO output to the rising edge of the HO output
- The falling edge of the HO output to the rising edge of the LO output

The propagation delay from the PWM input to the falling edge on LO or HO is not affected by the adjustable dead time delay circuit. For example, when PWM goes high, LO goes low from the PWM with the LO propagation delay and HO goes high after the dead time delay set by the RDT resistor. Similarly, when PWM goes low, HO goes low from the PWM with the HO propagation delay and LO goes high after the dead time delay set by the RDT resistor.

The recommended resistance range on RDT pin to VSS is 10kΩ to 100kΩ, which sets a dead time delay range typically of 35ns to 350ns. If resistance is less than 1kΩ, the adjustable dead time delay is disabled and the nominal dead time delay on the rising edge is 15ns. Renesas recommends shorting the RDT pin to VSS to disable the adjustable delay function. The dead time delay set by the RDT resistor is adjustable on the fly in operation except for the disabled condition, where the disabled state is detected and latched in on POR and resets after going through UVLO. Resistance values outside of 10kΩ to 100kΩ produce a faster or slower dead time delay beyond the 35ns to 350ns range but the accuracy and matching performance is not guaranteed.

A 1.2V reference on the RDT pin drives a current through the RDT resistor. The current is mirrored and drives an internal oscillator to set the dead time delay.

**Note:** Because the RDT pin signal is analog, as the RDT resistance is increased, the sensitivity to parasitic capacitive and inductive pickup increases. When laying out the PCB, keep high dv/dt nodes away from the RDT pin and resistor. Guard ringing and/or shielding can also be used to shunt away dv/dt injected currents.

## 5.9 HO and LO Outputs

The HO and LO driver outputs can source 3A peak and sink 4A peak currents for driving capacitive loads such as the NMOS gate-source terminals. The strong gate drive allows low  $r_{DS(ON)}$ , high  $Q_{gs}$  FETs to be switched on and off quickly with minimal switching loss during the voltage and current cross-over region at the NMOS FET drain and source.

The fast propagation delay (15ns typical) and excellent delay matching (2ns typical) supports wide duty cycle and high-frequency applications robustly up to 1MHz.

Additionally, the LO pin has a pull-down impedance to VSS of 140kΩ and the HO pin has a pull-down impedance to HS of 450kΩ. These internal pull-down resistors prevent charge accumulation at the external NMOS FET gate-source capacitance that would turn on the FETs when there is no VDD bias on the HIP2210/HIP2211 driver, preventing a possible shoot-through condition at initial power-up.

## 5.10 Power Dissipation

The power dissipation of the HIP2210/HIP2211 is typically dominated by the gate charge required by the driven bridge MOSFETs and the switching frequency. The internal bias, boot diode, and MOSFET gate leakage also contribute to the total dissipation, but these losses are usually less significant compared to the switching gate

charge losses. The calculation of the power dissipation of the HIP2210/HIP2211 is approximated by [Equation 3](#) through [Equation 9](#):

### 5.10.1 Gate Power (for the HO and LO Outputs)

$$(EQ. 3) \quad P_{\text{gate}} = (Q_{\text{gateH}} + Q_{\text{gateL}}) \times \text{Freq} \times V_{\text{DD}}$$

where  $Q_{\text{gateH}}$  and  $Q_{\text{gateL}}$  are the total gate charge of the high-side and low-side bridge FET, respectively.

This information is commonly found in the MOSFET datasheet typical performance curves for  $Q_{\text{gs}}$  vs Gate Voltage.  $V_{\text{DD}}$  is the bias to the HIP2210/HIP2211 and  $\text{Freq}$  is the PWM switching frequency operation.

### 5.10.2 Boot Diode Dissipation

[Equation 4](#) and [Equation 5](#) represent the boot diode conduction loss from recharging the boot capacitor during the boot refresh cycle (phase node is low). The average current is proportional to the total charge delivered to the high-side NMOS FET and the switching frequency.

$$(EQ. 4) \quad I_{\text{diode\_avg}} = Q_{\text{gate}} \times \text{Freq}$$

$$(EQ. 5) \quad P_{\text{diode}} = I_{\text{diode\_avg}} \times (0.7V + I_{\text{diode\_avg}} \times R_{\text{diode}})$$

where 0.7V is the typical internal boot diode forward voltage of the HIP2210/HIP2211, and  $R_{\text{diode}}$  is the dynamic resistance of the boot diode. See [Figure 22](#) and [Figure 23](#).

### 5.10.3 Dynamic Operating Current

$$(EQ. 6) \quad P_{\text{dynamic}} = I_{\text{dynamic}} \times V_{\text{HB}}$$

where  $I_{\text{dynamic}}$  is the dynamic operating current of the HIP2210 or HIP2211 into the HB pin at the switching frequency.

$V_{\text{HB}}$  is the average boot to phase voltage and is approximately  $V_{\text{HB}} - V_{\text{HS}} = V_{\text{DD}} - 0.7V$ .

### 5.10.4 Total Power Dissipation

$$(EQ. 7) \quad P_{\text{total}} = P_{\text{gate}} + P_{\text{diode}} + P_{\text{dynamic}}$$

### 5.10.5 Junction Operating Temperature

$$(EQ. 8) \quad T_{\text{J}} = P_{\text{total}} \times \theta_{\text{JA}} + T_{\text{A}}$$

where  $T_{\text{J}}$  is the junction temperature at the operating ambient temperature in the vicinity of the part,  $T_{\text{A}}$ .

$$(EQ. 9) \quad T_{\text{J}} = P_{\text{total}} \times \theta_{\text{JC}} + T_{\text{PCB}}$$

where  $T_{\text{J}}$  is the junction temperature with the operating temperature of the PCB,  $T_{\text{PCB}}$ , as measured where the EPAD is soldered.

## 6. PCB Layout Guidelines

The AC performance of the HIP2210/HIP2211 depends significantly on the design of the PCB. The following layout design guidelines are recommended to achieve optimum switching performance:

- It may be necessary to add resistance to dampen resonating parasitic circuits. PCB designs with long trace lengths on the LO and HO outputs may require series gate resistors on the bridge FETs to dampen the oscillations. It is good practice to place 0Ω chip resistors in series with the HO and LO driver outputs to the MOSFET gates.
- The routing of the half-bridge switching phase node to the HIP2210/HIP2211 HS pin should implement optimum layout practices. The PCB trace should be short and wide to minimize lead inductance. Also, route the HO trace directly above or below the HS trace to minimize ground loops.
- Understand how power currents flow. The high amplitude di/dt currents of the half-bridge FETs induce significant voltage transients on the associated traces and ground planes. Keep these high current paths away from sensitive low voltage signal traces.
- Avoid paralleling high di/dt traces with low-level signal lines. High di/dt induces currents in the low-level signal lines.
- Keep power loops as short as possible by routing the source and return traces on adjacent layers, directly above and beneath each other.
- When practical, minimize impedances in low-level signal circuits. The noise magnetically induced on a 10k resistor is 10x larger than the noise on a 1k resistor.
- Be aware of magnetic fields emanating from transformers and inductors. Core gaps in these structures are especially bad for emitting flux.
- If you must have traces close to magnetic devices, align the traces so that they are parallel to the flux lines.
- Use low inductance components such as SMD chip resistors and chip capacitors with low Equivalent Series Inductance (ESL).
- Use decoupling capacitors to reduce the influence of parasitic inductance. To be effective, these capacitors must also have the shortest possible lead lengths to the component pins. If vias are used, connect several paralleled vias to reduce their inductance.
- Keep high dv/dt nodes away from low-level circuits. Guard ringing and/or shielding can be used to shunt away dv/dt injected currents from sensitive circuits. This is especially true for the RDT pin and resistor, and also the PWM and HI/LI signals.
- Avoid having a signal ground plane under a high dv/dt circuit. This injects high di/dt currents into the signal ground paths.
- Calculate power dissipation and voltage drop calculations for the power traces. Most PCB/CAD programs have built-in tools for calculation of trace resistance.
- Large power components (power FETs, electrolytic capacitors, power resistors, etc.) have internal parasitic inductance, which cannot be eliminated. Accounted for this in the PCB layout and circuit design.
- If you simulate your circuits, consider including parasitic components.
- If available, connect the EPAD on the bottom side of the package to the PCB ground plane with thermal vias for heat removal.

### 6.1 PCB Layout and EPAD Recommendation

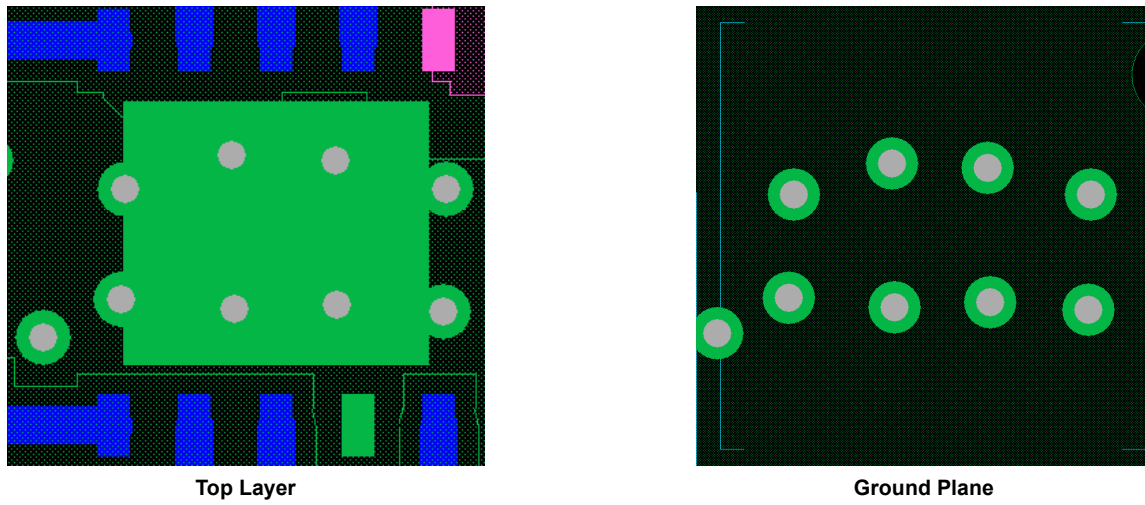

Figure 32. Recommended PCB Heatsink

## 7. Revision History

Rev.	Date	Description
1.02	Jun.23.20	Updated Robust noise tolerance Features bullet. Added Evaluation Boards to the Ordering Information table. Updated the Voltage on HS minimum specification from -1V to The greater of [-10 or -(20 - VDD)] in the Absolute Maximum Ratings and Recommended Operating Conditions sections. Removed the Transient Voltage on HS (Repetitive Transient for 100ns) specification from Absolute Maximum Ratings section. Removed the Transient Voltage on HS (Repetitive Transient for 10ns specification from Recommended Operating Conditions section.
1.01	Mar.16.20	Added 8 Ld DFN information throughout.
1.00	Feb.19.20	Initial release

### 8. Package Outline Drawings

For the most recent package outline drawing, see [L10.4x4](#).

L10.4x4  
 10 Lead Thin Dual Flat No-Lead Plastic Package (TDFN)  
 Rev 2, 4/15

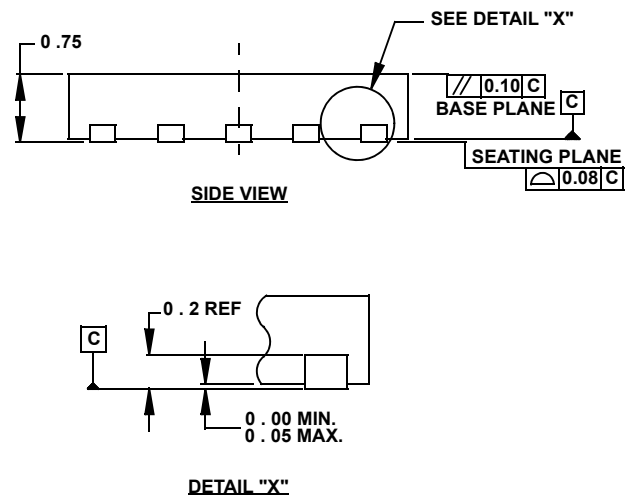
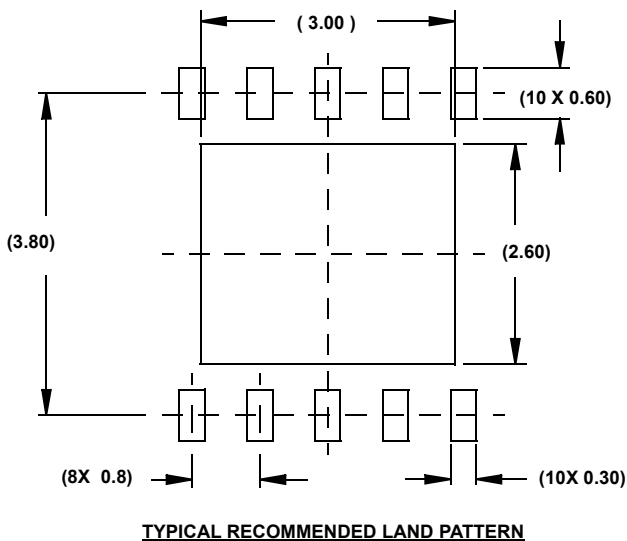
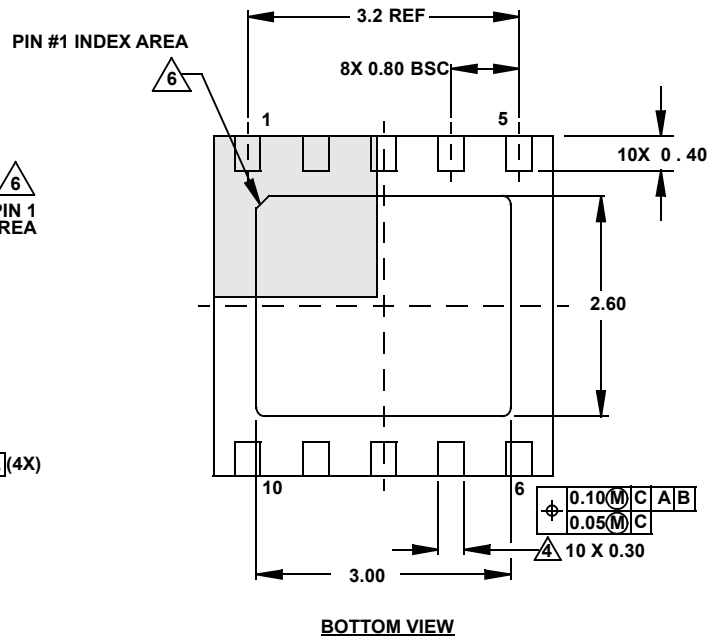
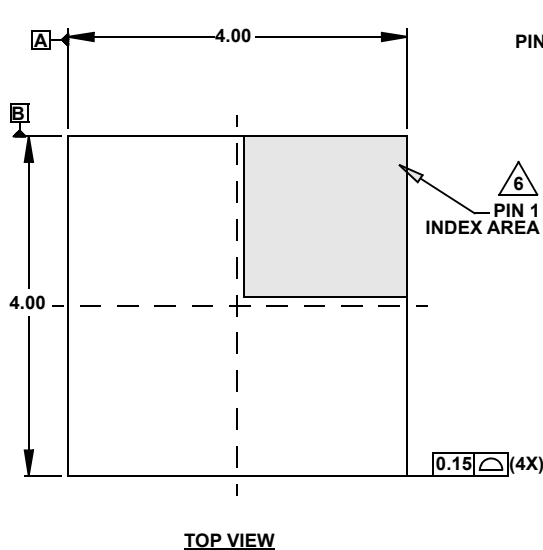

**NOTES:**

- Dimensions are in millimeters.  
Dimensions in ( ) for Reference Only.
  - Dimensioning and tolerancing conform to AMSE Y14.5m-1994.
  - Unless otherwise specified, tolerance : Decimal  $\pm 0.05$
  - Dimension b applies to the metallized terminal and is measured between 0.15mm and 0.30mm from the terminal tip.
  - Tiebar shown (if present) is a non-functional feature and may be located on any of the 4 sides (or ends).
  - The configuration of the pin #1 identifier is optional, but must be located within the zone indicated. The pin #1 identifier may be either a mold or mark feature.
- either a mold or mark feature.

M8.15  
 8 Lead Narrow Body Small Outline Plastic Package (SOIC)  
 Rev 4, 1/12

For the most recent package outline drawing, see [M8.15](#).

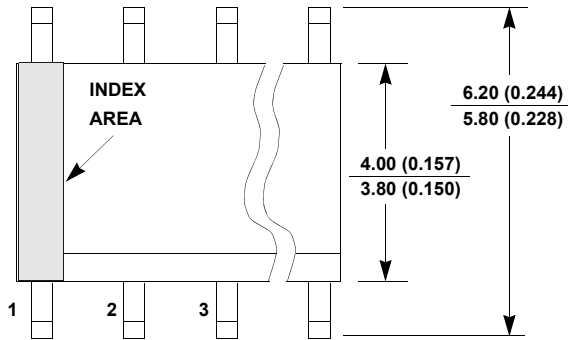

**TOP VIEW**

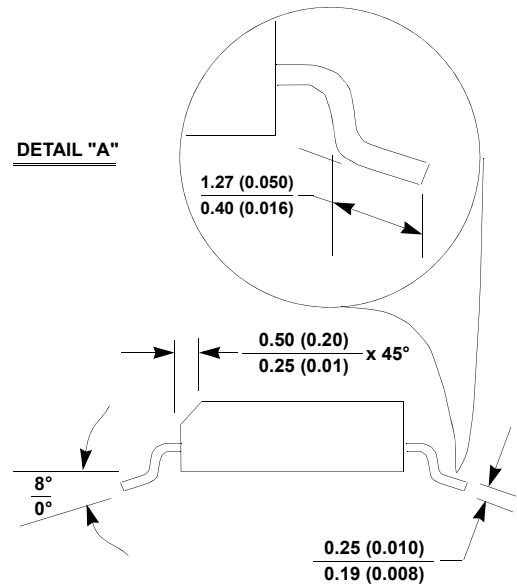

**SIDE VIEW "B"**

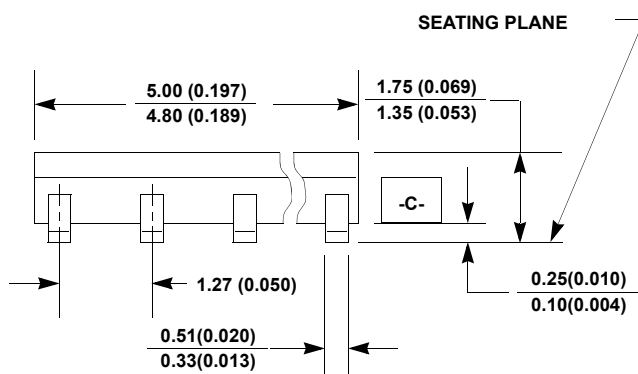

**SIDE VIEW "A"**

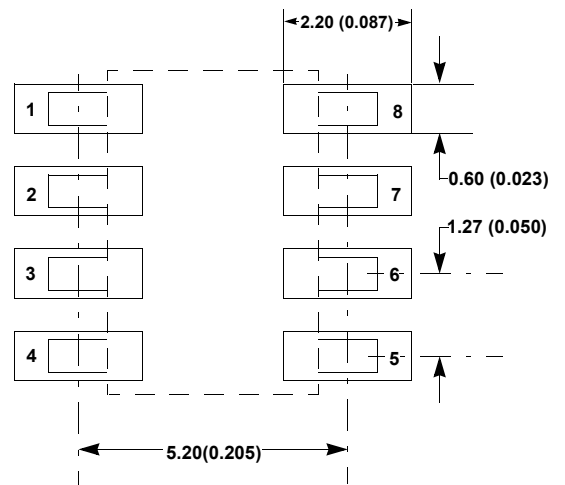

**TYPICAL RECOMMENDED LAND PATTERN**

**Notes:**

1. Dimensioning and tolerancing per ANSI Y14.5M-1994.
2. Package length does not include mold flash, protrusions or gate burrs. Mold flash, protrusion and gate burrs shall not exceed 0.15mm (0.006 inch) per side.
3. Package width does not include interlead flash or protrusions. Interlead flash and protrusions shall not exceed 0.25mm (0.010 inch) per side.
4. The chamfer on the body is optional. If it is not present, a visual index feature must be located within the crosshatched area.
5. Terminal numbers are shown for reference only.
6. The lead width as measured 0.36mm (0.014 inch) or greater above the seating plane, shall not exceed a maximum value of 0.61mm (0.024 inch).
7. Controlling dimension: MILLIMETER. Converted inch dimensions are not necessarily exact.
8. This outline conforms to JEDEC publication MS-012-AA ISSUE C.

L8.4x4  
 8 Lead Dual Flat No-Lead Plastic Package (DFN)  
 Rev 1, 03/15

For the most recent package outline drawing, see [L8.4x4](#).

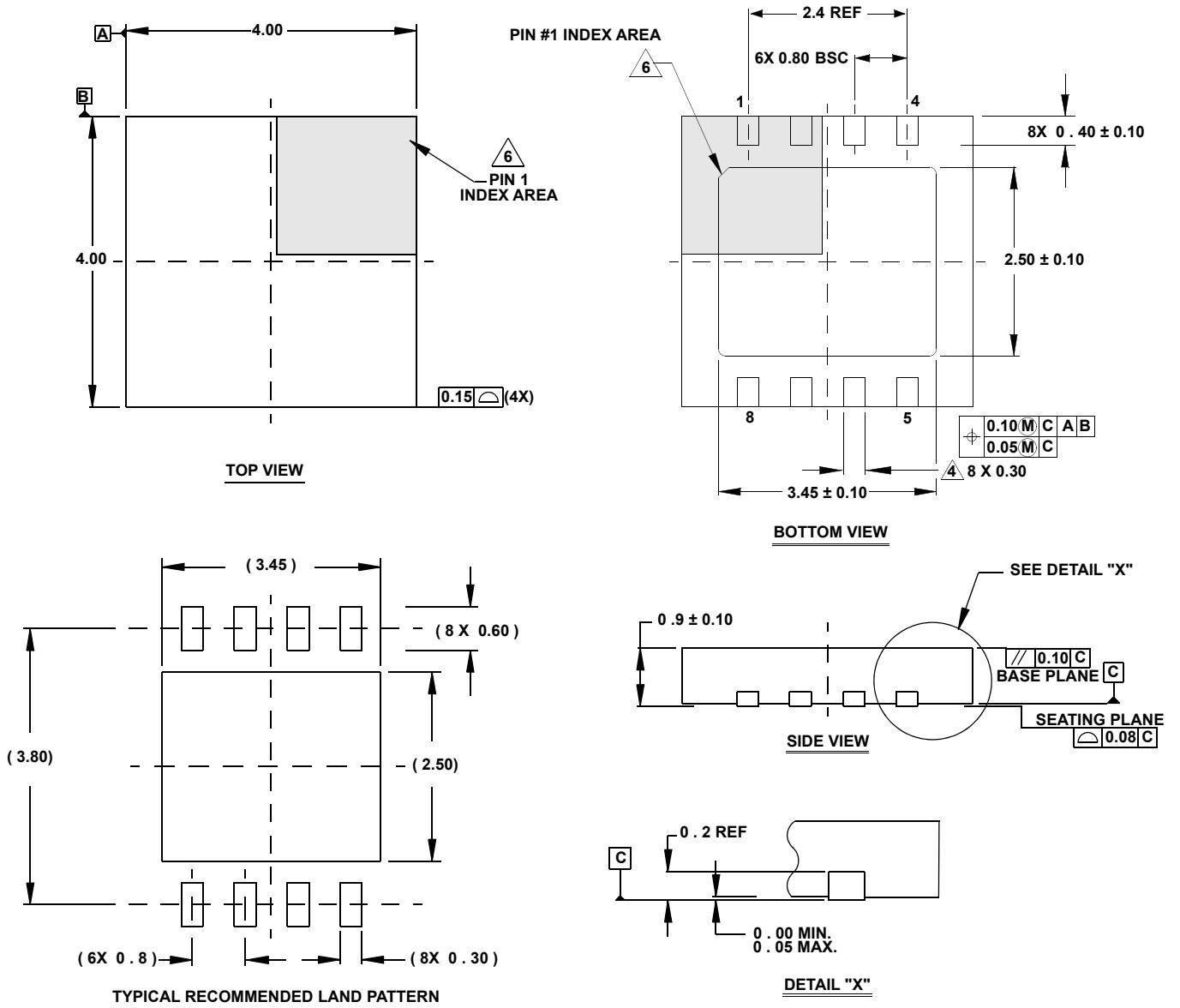

NOTES:

1. Dimensions are in millimeters.  
Dimensions in ( ) for Reference Only.
2. Dimensioning and tolerancing conform to ASME Y14.5m-1994.
3. Unless otherwise specified, tolerance : Decimal ± 0.05
4. Dimension applies to the metallized terminal and is measured between 0.15mm and 0.30mm from the terminal tip.
5. Tiebar shown (if present) is a non-functional feature and may be located on any of the 4 sides (or ends).
6. The configuration of the pin #1 identifier is optional, but must be located within the zone indicated. The pin #1 identifier may be either a mold or mark feature.

## IMPORTANT NOTICE AND DISCLAIMER

RENESAS ELECTRONICS CORPORATION AND ITS SUBSIDIARIES (“RENESAS”) PROVIDES TECHNICAL SPECIFICATIONS AND RELIABILITY DATA (INCLUDING DATASHEETS), DESIGN RESOURCES (INCLUDING REFERENCE DESIGNS), APPLICATION OR OTHER DESIGN ADVICE, WEB TOOLS, SAFETY INFORMATION, AND OTHER RESOURCES “AS IS” AND WITH ALL FAULTS, AND DISCLAIMS ALL WARRANTIES, EXPRESS OR IMPLIED, INCLUDING, WITHOUT LIMITATION, ANY IMPLIED WARRANTIES OF MERCHANTABILITY, FITNESS FOR A PARTICULAR PURPOSE, OR NON-INFRINGEMENT OF THIRD PARTY INTELLECTUAL PROPERTY RIGHTS.

These resources are intended for developers skilled in the art designing with Renesas products. You are solely responsible for (1) selecting the appropriate products for your application, (2) designing, validating, and testing your application, and (3) ensuring your application meets applicable standards, and any other safety, security, or other requirements. These resources are subject to change without notice. Renesas grants you permission to use these resources only for development of an application that uses Renesas products. Other reproduction or use of these resources is strictly prohibited. No license is granted to any other Renesas intellectual property or to any third party intellectual property. Renesas disclaims responsibility for, and you will fully indemnify Renesas and its representatives against, any claims, damages, costs, losses, or liabilities arising out of your use of these resources. Renesas' products are provided only subject to Renesas' Terms and Conditions of Sale or other applicable terms agreed to in writing. No use of any Renesas resources expands or otherwise alters any applicable warranties or warranty disclaimers for these products.

(Rev.1.0 Mar 2020)

### Corporate Headquarters

TOYOSU FORESIA, 3-2-24 Toyosu,  
Koto-ku, Tokyo 135-0061, Japan  
[www.renesas.com](http://www.renesas.com)

### Contact Information

For further information on a product, technology, the most up-to-date version of a document, or your nearest sales office, please visit:  
[www.renesas.com/contact/](http://www.renesas.com/contact/)

### Trademarks

Renesas and the Renesas logo are trademarks of Renesas Electronics Corporation. All trademarks and registered trademarks are the property of their respective owners.

# Mouser Electronics

Authorized Distributor

Click to View Pricing, Inventory, Delivery & Lifecycle Information:

## Renesas Electronics:

[HIP2211FBZ-T7A](#) [HIP2211FRTZ-T7A](#) [HIP2210FRTZ](#) [HIP2210FRTZ-T](#) [HIP2210FRTZ-T7A](#) [HIP2211FBZ](#)  
[HIP2211FBZ-T](#) [HIP2211FR8Z](#) [HIP2211FR8Z-T](#) [HIP2211FR8Z-T7A](#) [HIP2211FRTZ](#) [HIP2211FRTZ-T](#)

## Looking for pricing, stock, or lifecycle information?

Click below to explore more details on WIN SOURCE:

-  [View HIP2210FRTZ-T on WIN SOURCE](#)
-  [Renesas Electronics America Information](#)

## Optimize Your Supply Chain with WIN SOURCE Solutions

-  Global Sourcing Solution
-  Obsolete Management
-  Cost Control Management
-  Shortage Management
-  Alternative Solution
-  Excess Inventory Management