

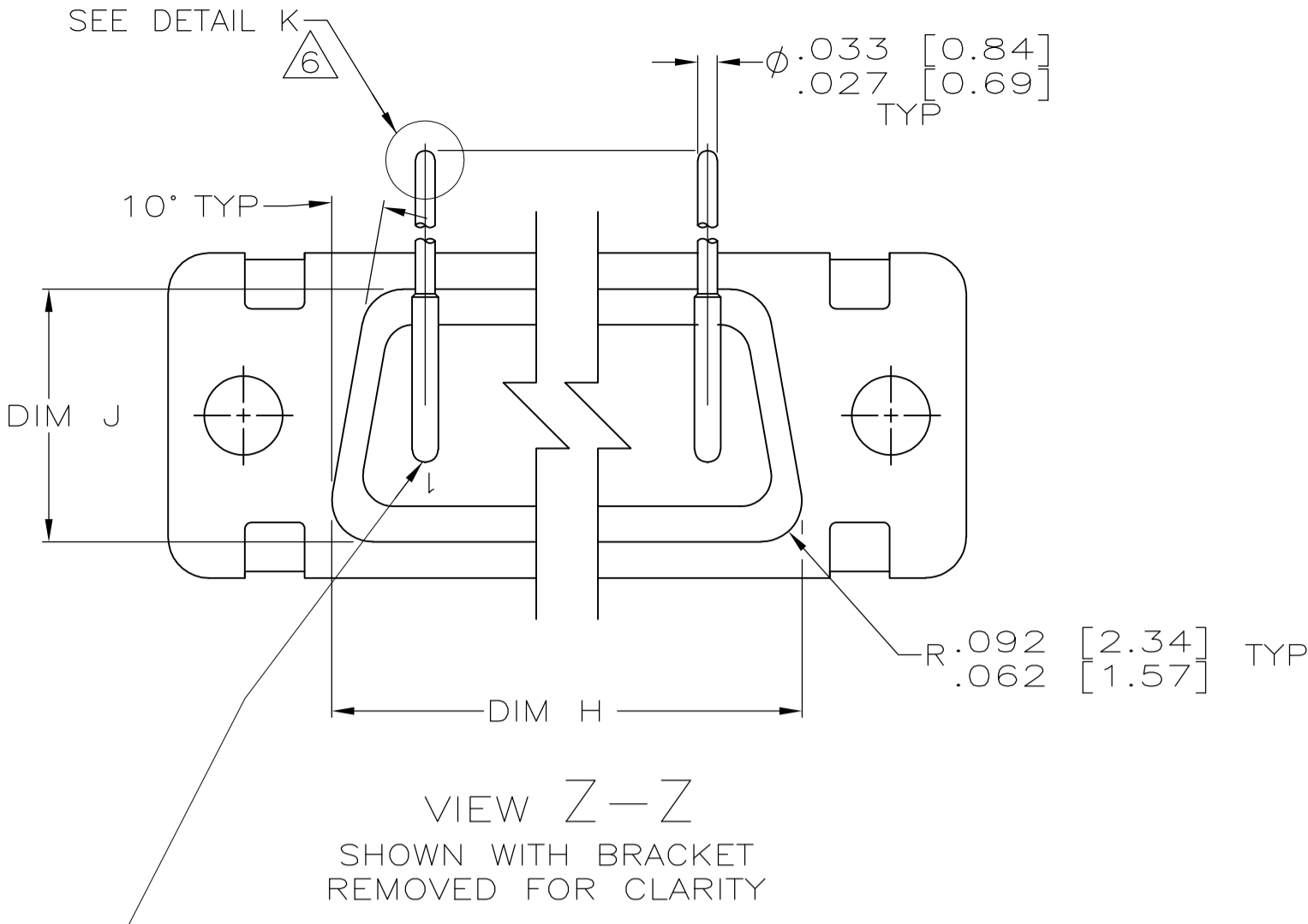

LOC	DIST	REV	DESCRIPTION	DATE	BY	APPV
C	REV PER ECO-07-017102			20SEP07	PY	BW

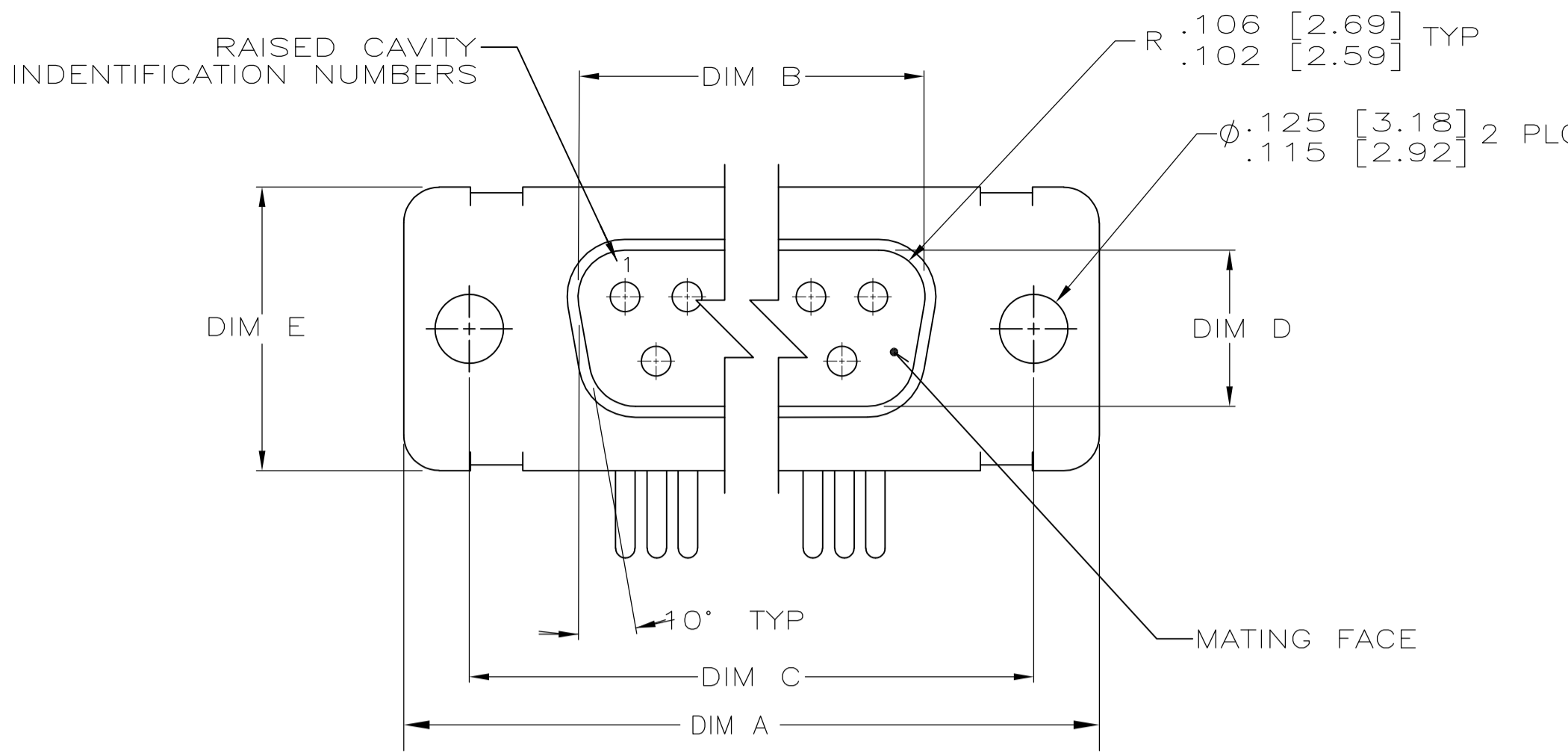

CONTACT (QTY = NO. OF POSN)  
 MATL: BRASS PER ASTM-B-16, OR BERYLLIUM COPPER PER ASTM-B-194  
 FINISH: GOLD PER MIL-G-45204, TYPE II, GRADE C, CLASS 1 IN CONTACT MATING AREA, .000010 [0.0003] MIN THK GOLD PER MIL-G-45204 OVER .000050 [0.0013] MIN THK NICKEL PER QQ-N-290 ON CONTACT BODY

- 1. SEE SHEET 2 FOR RECOMMENDED P.C. BOARD LAYOUT. TRUE POSITION TOLERANCE FOR P.C. BOARD LAYOUT IS .010 [0.25] AT MAX MATERIAL CONDITION. SUGGESTED BOARD THICKNESS IS .062 [1.57]
  - 2. THE CONNECTORS DESCRIBED IN THIS DOCUMENT MEET THE REQUIREMENTS OF MIL-C-24308 AND MATE WITH ANY RECEPTACLE CONNECTOR WITH SAME INSERT ARRANGEMENT.
  - 3. MARKED WITH .047 [1.19]-.062 [1.57] HIGH CHARACTERS. FAR SIDE REFERS TO THE WIDE SIDE OF THE KEYSTONE. NEAR SIDE REFERS TO THE NARROW SIDE OF THE KEYSTONE. IF THE REAR SHELL IS TOO SMALL FOR THE ENTIRE MILITARY PART NUMBER, MARKING SHALL BE LOCATED AS FOLLOWS:
    - A. "M24308" ON FRONT SHELL, FAR SIDE.
    - B. SLASH SHEET AND DASH NUMBER ON REAR SHELL, FAR SIDE.
    - C. "AMP" AND DATE CODE ON FRONT SHELL, NEAR SIDE.
    - D. AMP PART NUMBER ON REAR SHELL, NEAR SIDE.
- IF THE FRONT SHELL IS TOO SMALL FOR "AMP", AMP PART NUMBER AND DATE CODE, MARKING SHALL BE SPLIT AS FOLLOWS:
- A. AMP PART NUMBER ON REAR SHELL, NEAR SIDE.
  - B. "AMP" AND DATE CODE ON FRONT SHELL, NEAR SIDE.
  - C. MILITARY PART NUMBER ON REAR SHELL, FAR SIDE.

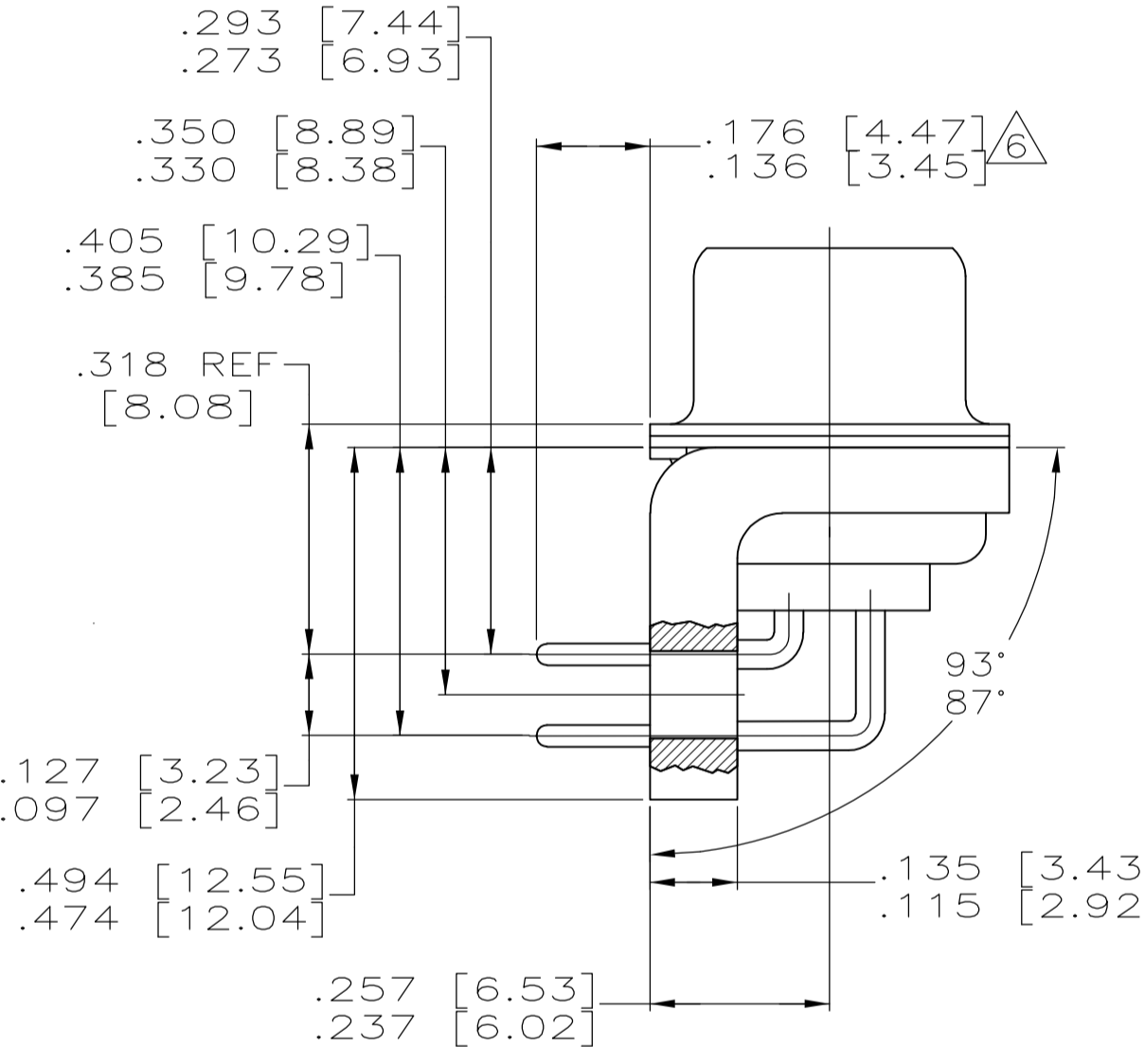
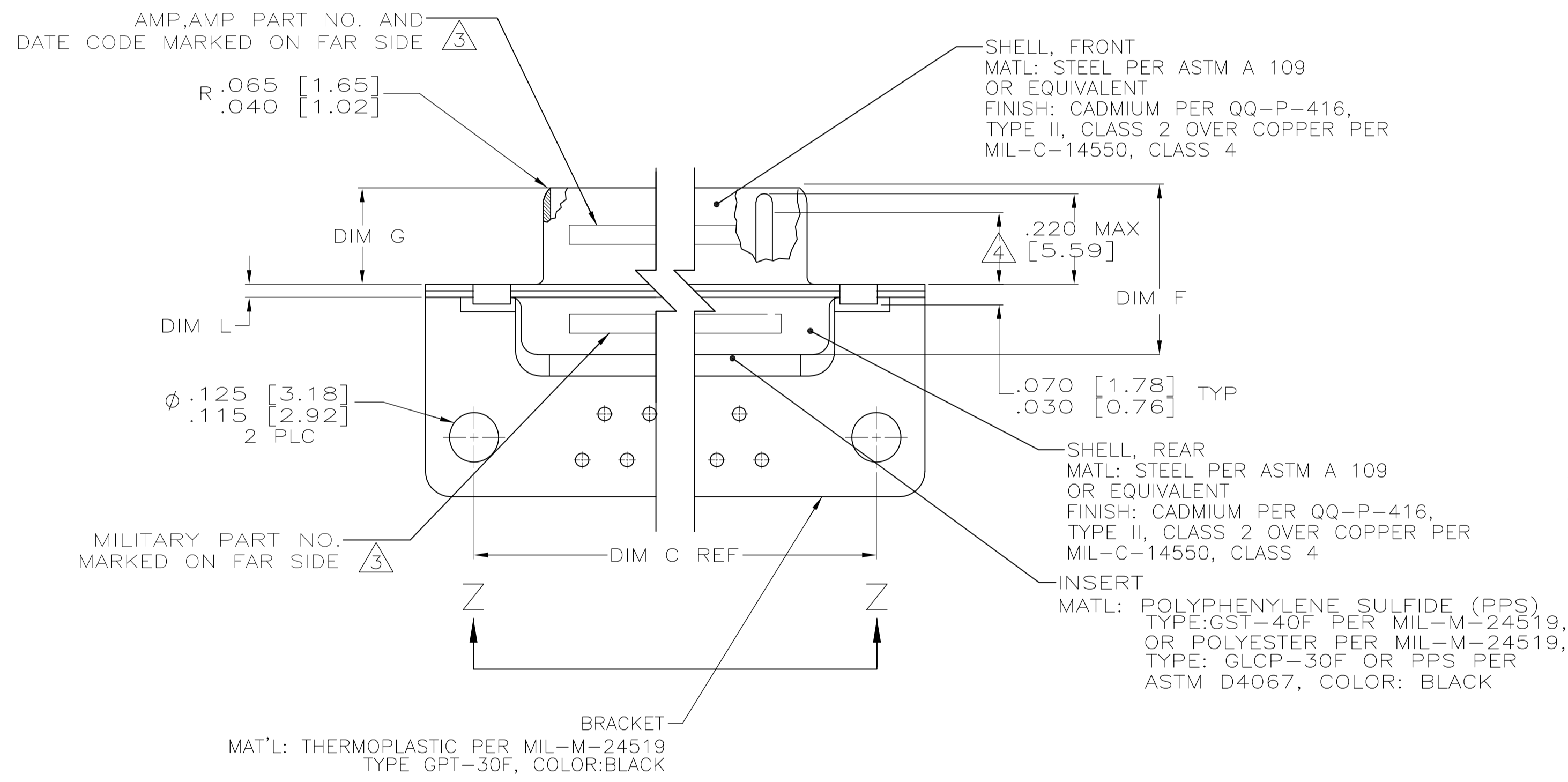

SHELL SIZES 1 THRU 4 CONTACT CONFIGURATION

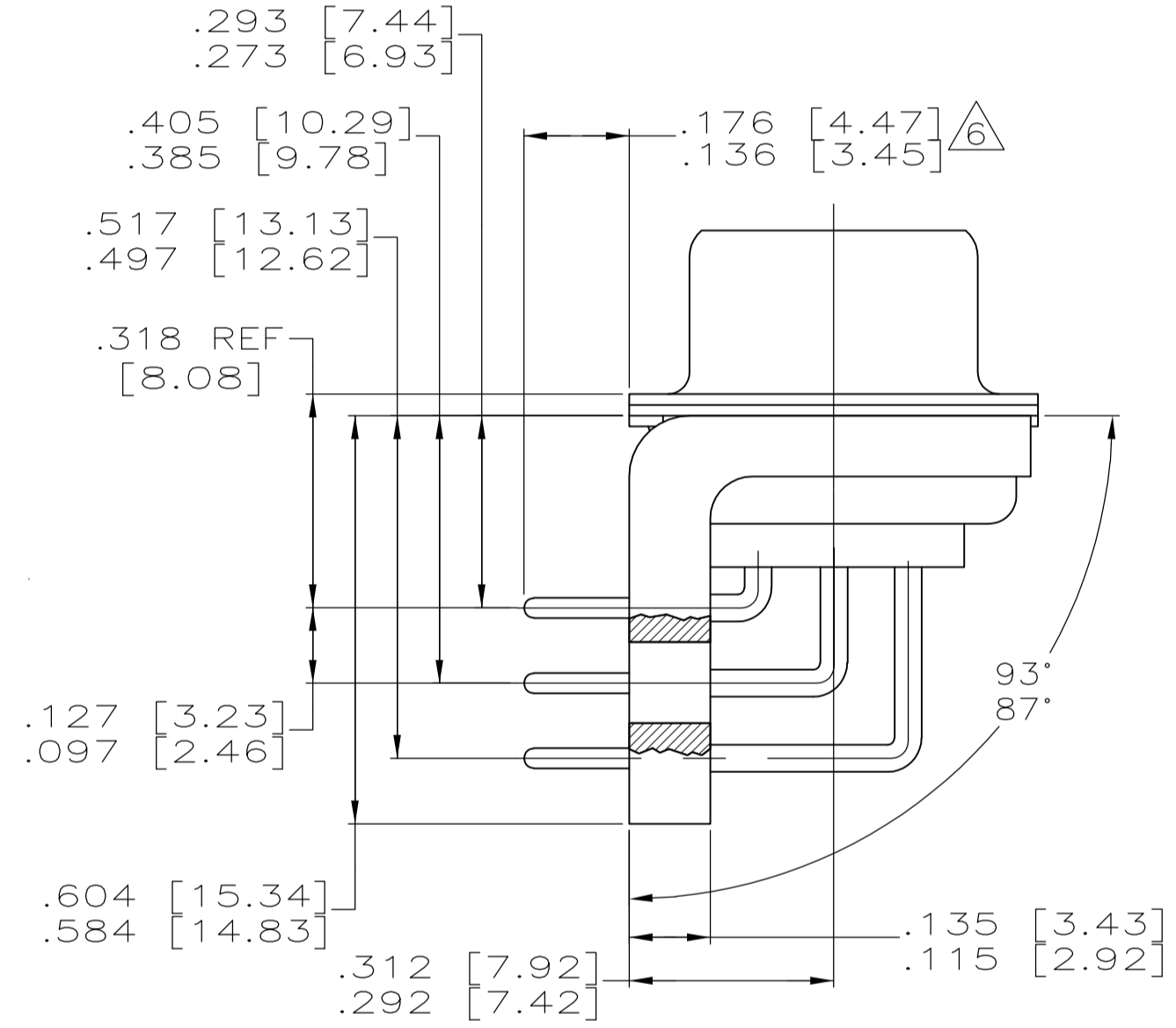

SHELL SIZE 5 CONTACT CONFIGURATION

.049 [1.24]	.544 [13.82]	2.188 [55.58]	.236 [5.99]	.436 [11.07]	.620 [15.75]	.446 [11.33]	2.411 [61.24]	2.084 [52.55]	2.650 [67.31]	MS18277-1	50	5	M24308/24-35F	1218441-5	1-1218441-0
.029 [0.74]	.524 [13.31]	2.168 [55.07]	.224 [5.69]	.416 [10.57]	.590 [14.99]	.436 [11.07]	2.401 [60.99]	2.074 [52.30]	2.620 [66.55]	MS18276-1	37	4	M24308/24-34F	1218441-4	1218441-9
.049 [1.24]	.432 [10.97]	2.282 [57.96]	.236 [5.99]	.436 [11.07]	.509 [12.93]	.334 [8.48]	2.505 [63.63]	2.187 [54.97]	2.744 [69.70]	MS18275-1	25	3	M24308/24-33F	1218441-3	1218441-8
.029 [0.74]	.412 [10.46]	2.262 [57.45]	.224 [5.69]	.416 [10.57]	.479 [12.17]	.324 [8.23]	2.495 [63.37]	2.177 [54.71]	2.714 [68.94]	MS18274-1	15	2	M24308/24-32F	1218441-2	1218441-7
.049 [1.24]	.432 [10.97]	1.635 [41.53]	.236 [5.99]	.436 [11.07]	.509 [12.93]	.334 [8.48]	1.857 [47.17]	1.539 [38.51]	2.103 [53.42]	MS18273-1	9	1	M24308/24-31F	1218441-1	1218441-6
.029 [0.74]	.412 [10.46]	1.615 [41.02]	.224 [5.69]	.416 [10.57]	.479 [12.17]	.324 [8.23]	1.847 [46.91]	1.529 [38.25]	2.073 [52.65]	MS18277-1	50	5	M24308/24-35F	1218441-5	1218441-5
.049 [1.24]	.432 [10.97]	2.282 [57.96]	.236 [5.99]	.436 [11.07]	.509 [12.93]	.334 [8.48]	2.505 [63.63]	2.187 [54.97]	2.744 [69.70]	MS18276-1	37	4	M24308/24-34F	1218441-4	1218441-4
.029 [0.74]	.412 [10.46]	2.262 [57.45]	.224 [5.69]	.416 [10.57]	.479 [12.17]	.324 [8.23]	2.495 [63.37]	2.177 [54.71]	2.714 [68.94]	MS18275-1	25	3	M24308/24-33F	1218441-3	1218441-3
.049 [1.24]	.432 [10.97]	1.635 [41.53]	.236 [5.99]	.436 [11.07]	.509 [12.93]	.334 [8.48]	1.857 [47.17]	1.539 [38.51]	2.103 [53.42]	MS18274-1	15	2	M24308/24-32F	1218441-2	1218441-2
.029 [0.74]	.412 [10.46]	1.615 [41.02]	.224 [5.69]	.416 [10.57]	.479 [12.17]	.324 [8.23]	1.847 [46.91]	1.529 [38.25]	2.073 [52.65]	MS18273-1	9	1	M24308/24-31F	1218441-1	1218441-1
.049 [1.24]	.544 [13.82]	2.188 [55.58]	.236 [5.99]	.436 [11.07]	.620 [15.75]	.446 [11.33]	2.411 [61.24]	2.084 [52.55]	2.650 [67.31]	MS18277-1	50	5	M24308/24-35F	1218441-5	1218441-5
.029 [0.74]	.524 [13.31]	2.168 [55.07]	.224 [5.69]	.416 [10.57]	.590 [14.99]	.436 [11.07]	2.401 [60.99]	2.074 [52.30]	2.620 [66.55]	MS18276-1	37	4	M24308/24-34F	1218441-4	1218441-4
.049 [1.24]	.432 [10.97]	2.282 [57.96]	.236 [5.99]	.436 [11.07]	.509 [12.93]	.334 [8.48]	2.505 [63.63]	2.187 [54.97]	2.744 [69.70]	MS18275-1	25	3	M24308/24-33F	1218441-3	1218441-3
.029 [0.74]	.412 [10.46]	2.262 [57.45]	.224 [5.69]	.416 [10.57]	.479 [12.17]	.324 [8.23]	2.495 [63.37]	2.177 [54.71]	2.714 [68.94]	MS18274-1	15	2	M24308/24-32F	1218441-2	1218441-2
.049 [1.24]	.432 [10.97]	1.635 [41.53]	.236 [5.99]	.436 [11.07]	.509 [12.93]	.334 [8.48]	1.857 [47.17]	1.539 [38.51]	2.103 [53.42]	MS18273-1	9	1	M24308/24-31F	1218441-1	1218441-1
.029 [0.74]	.412 [10.46]	1.615 [41.02]	.224 [5.69]	.416 [10.57]	.479 [12.17]	.324 [8.23]	1.847 [46.91]	1.529 [38.25]	2.073 [52.65]	MS18277-1	50	5	M24308/24-35F	1218441-5	1218441-5
.049 [1.24]	.432 [10.97]	2.282 [57.96]	.236 [5.99]	.436 [11.07]	.509 [12.93]	.334 [8.48]	2.505 [63.63]	2.187 [54.97]	2.744 [69.70]	MS18276-1	37	4	M24308/24-34F	1218441-4	1218441-4
.029 [0.74]	.412 [10.46]	2.262 [57.45]	.224 [5.69]	.416 [10.57]	.479 [12.17]	.324 [8.23]	2.495 [63.37]	2.177 [54.71]	2.714 [68.94]	MS18275-1	25	3	M24308/24-33F	1218441-3	1218441-3
.049 [1.24]	.432 [10.97]	1.635 [41.53]	.236 [5.99]	.436 [11.07]	.509 [12.93]	.334 [8.48]	1.857 [47.17]	1.539 [38.51]	2.103 [53.42]	MS18274-1	15	2	M24308/24-32F	1218441-2	1218441-2
.029 [0.74]	.412 [10.46]	1.615 [41.02]	.224 [5.69]	.416 [10.57]	.479 [12.17]	.324 [8.23]	1.847 [46.91]	1.529 [38.25]	2.073 [52.65]	MS18273-1	9	1	M24308/24-31F	1218441-1	1218441-1

DIM L	DIM J	DIM H	DIM G	DIM F	DIM E	DIM D	DIM C	DIM B	DIM A	INSERT ARRANGEMENT	NO OF POS	SHELL SIZE	MILITARY P/N ON CONNECTOR	AMP P/N MARKED ON CONNECTOR	AMP PART NO.

DETAIL K  
 SCALE 8:1  
 FOR 1218441-6 THRU -10 ONLY

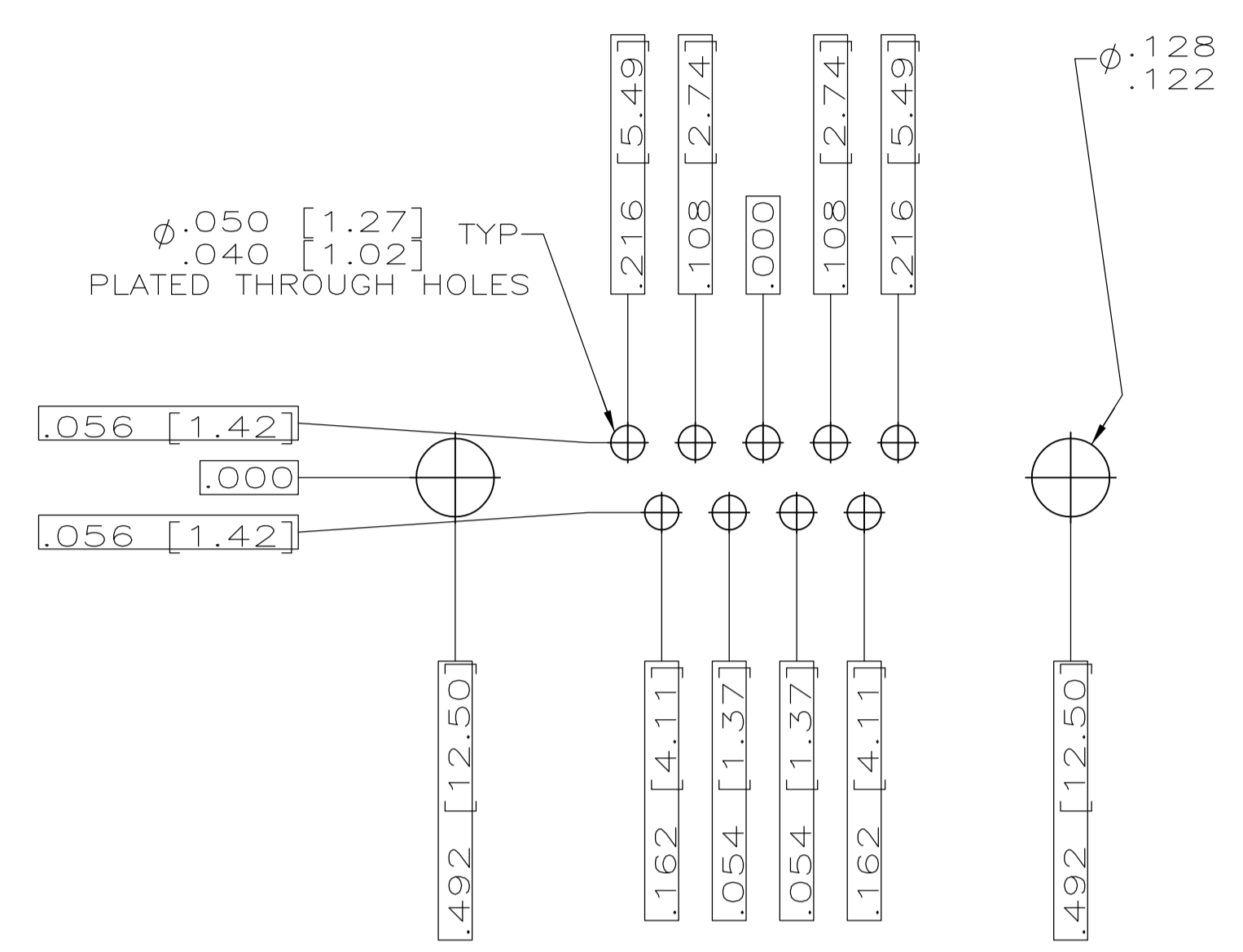

RECOMMENDED P.C. BOARD LAYOUT  
SHELL SIZE 1 (9 POSITION) ⚠

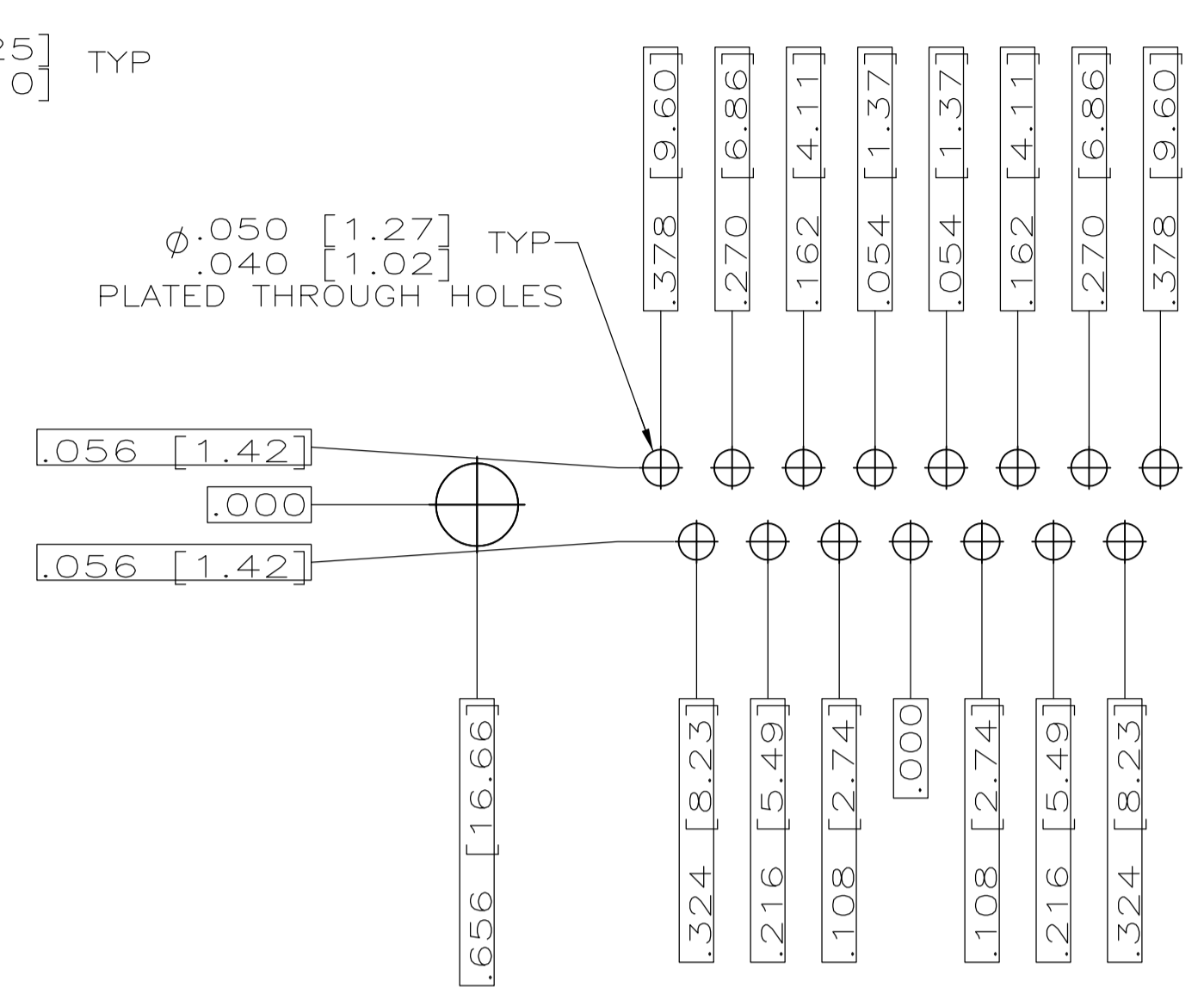

RECOMMENDED P.C. BOARD LAYOUT  
SHELL SIZE 2 (15 POSITION) ⚠

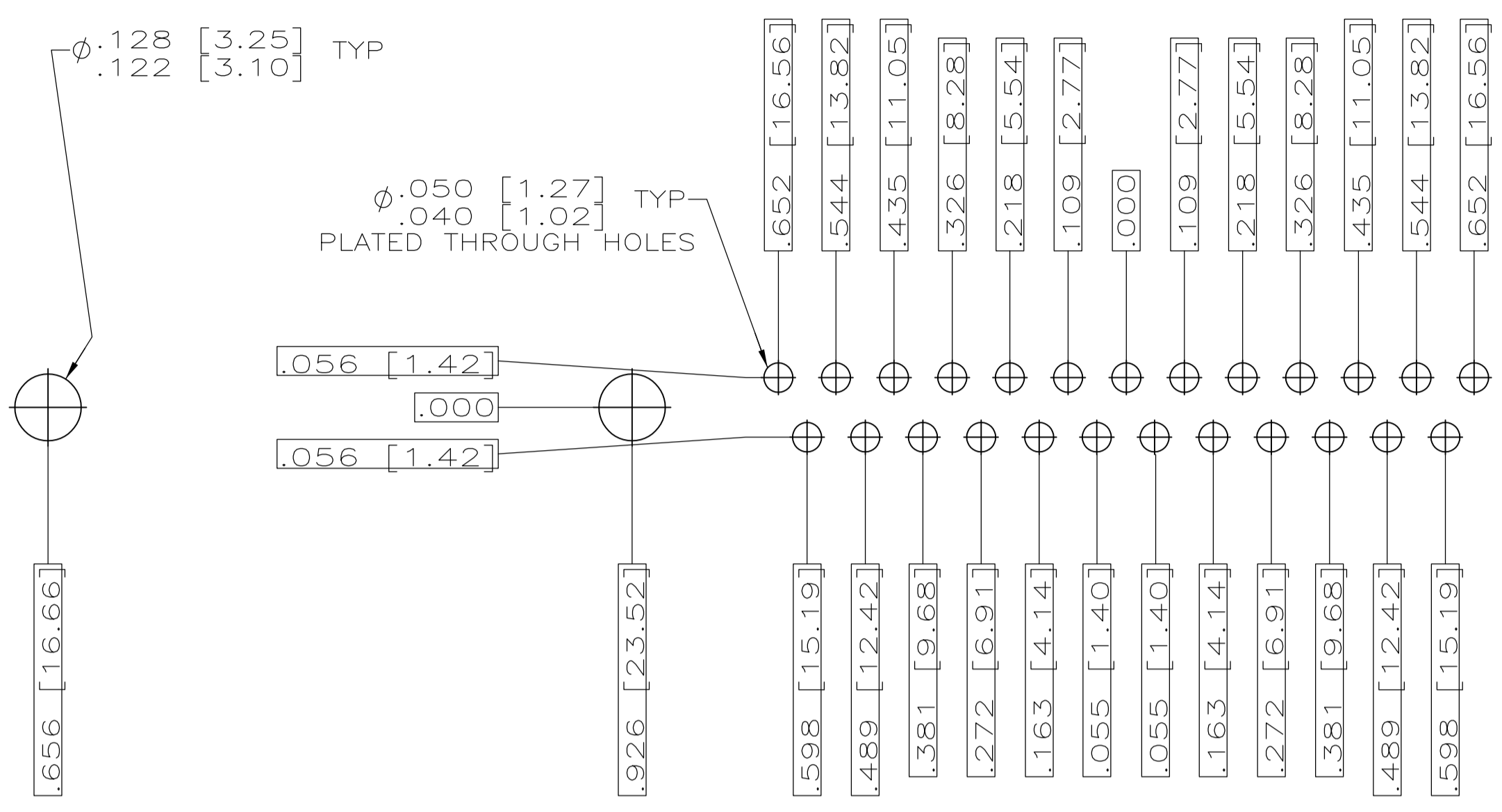

RECOMMENDED P.C. BOARD LAYOUT  
SHELL SIZE 3 (25 POSITION) ⚠

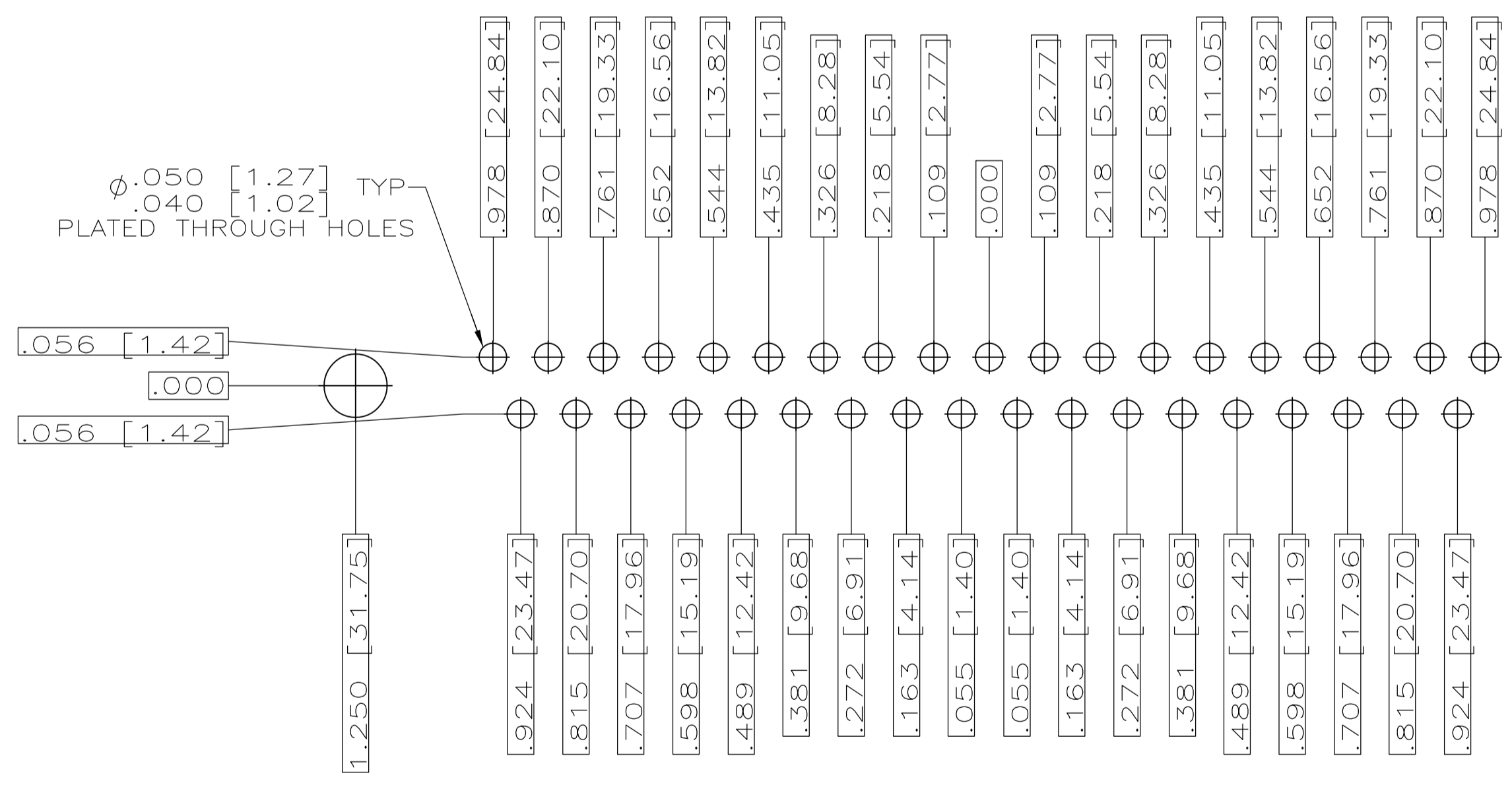

RECOMMENDED P.C. BOARD LAYOUT  
SHELL SIZE 4 (37 POSITION) ⚠

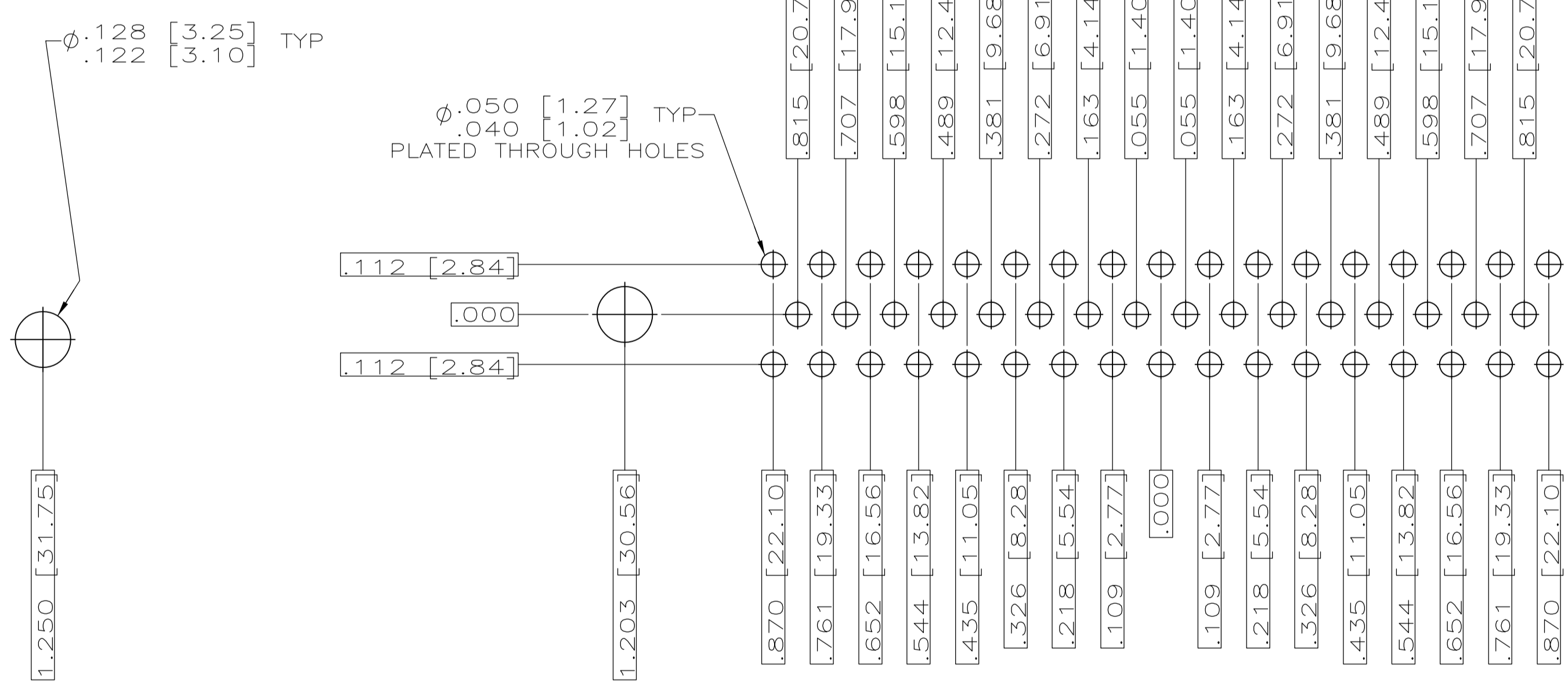

RECOMMENDED P.C. BOARD LAYOUT  
SHELL SIZE 5 (50 POSITION) ⚠

THIS DRAWING IS A CONTROLLED DOCUMENT.		DIN	C.C.THOMAS	12-6-99	Tyco Electronics Corporation Harrisburg, PA 17105-3608
DIMENSIONS: INCHES		CHK	CHAD BAKER	12-15-99	
TOLERANCES UNLESS OTHERWISE SPECIFIED:		APVD	CHAD BAKER	12-15-99	NAME PLUG ASSY,AMPLIMITE RIGHT ANGLE,SERIES 109,SIZE 1 THRU 5
0 PLC ± .005		APPLICATION SPEC		SIZE	
1 PLC ± .004		MATERIAL SEE CALLOUTS		WEIGHT	RESTRICTED TO
2 PLC ± .003		FINISH SEE CALLOUTS		A1 00779	SCALE 4:1
3 PLC ± .002		CUSTOMER DRAWING		1218441	SHEET 2 OF 2
4 PLC ± .001					REV C
5 PLCS ± .001					

## Looking for pricing, stock, or lifecycle information?

Click below to explore more details on WIN SOURCE:

 [View 1218441-2 on WIN SOURCE](#)

 [TE Connectivity](#) Information

## Optimize Your Supply Chain with WIN SOURCE Solutions

-  Global Sourcing Solution
-  Obsolete Management
-  Cost Control Management
-  Shortage Management
-  Alternative Solution
-  Excess Inventory Management