



THE DATASHEET OF
AL1783T16E-13



Description

The AL1783 is a three-channel linear LED driver with independent PWM dimming and current-setting controls for each channel. The device is designed to target connected, commercial, industrial, and RGB LED lighting applications.

The key merits of the AL1783 are attributed to a compact solution, eBOM cost effectiveness, excellent PWM dimming performance, low standby power, ease of system implementation, and up to 60V input and LED pin operating voltage.

The AL1783 is available in the TSSOP-16EP (Type DX) package to minimize PCB space and external component count.

Pin Assignments

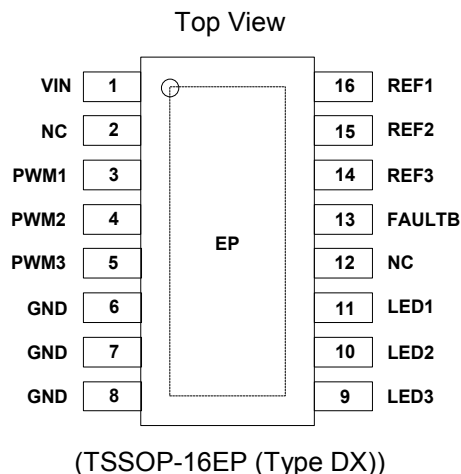

Features

- Wide Input Voltage Range from 6.5V to 60V
- -40°C to +105°C Ambient Temperature Operation Range
- ±4% LED Current Tolerance @125mA
- PWM Dimming Control for Each Channel
- LED Current Adjustable for Each Channel by External Ref pins
- Automatic Enter and Exit Standby Power Mode
- Fast PWM Dimming Capable to eliminate e-Flicker
- Robust Protections: Under Voltage Lock-out (UVLO), Over Voltage Protection (OVP), LED String Open/Short Protection (LED Short/Open)
 - Over Temperature Protection (OTP): Thermal Fold-back, Thermal Shut-down, and Automatic Thermal Recovery
- Fault Reporting: UVLO, OTP, LED Open and Short
- **Totally Lead-Free & Fully RoHS Compliant (Notes 1 & 2)**
- **Halogen- and Antimony-Free. "Green" Device (Note 3)**
- **For automotive applications requiring specific change control (i.e. parts qualified to AEC-Q100/101/200, PPAP capable, and manufactured in IATF 16949 certified facilities), please [contact us](https://www.diodes.com/quality/product-definitions/) or your local Diodes representative.**
<https://www.diodes.com/quality/product-definitions/>

Applications

- RGB Lighting
- Horticulture Lighting
- Architecture Lighting
- Industrial Lighting
- Commercial Lighting, i.e. Ceiling and Panel Light
- Connected Lighting

Notes:

1. No purposely added lead. Fully EU Directive 2002/95/EC (RoHS), 2011/65/EU (RoHS 2) & 2015/863/EU (RoHS 3) compliant.
2. See <https://www.diodes.com/quality/lead-free/> for more information about Diodes Incorporated's definitions of Halogen- and Antimony-free, "Green", and Lead-free.
3. Halogen- and Antimony-free "Green" products are defined as those which contain <900ppm bromine, <900ppm chlorine (<1500ppm total Br + Cl) and <1000ppm antimony compounds.

Typical Application Circuit

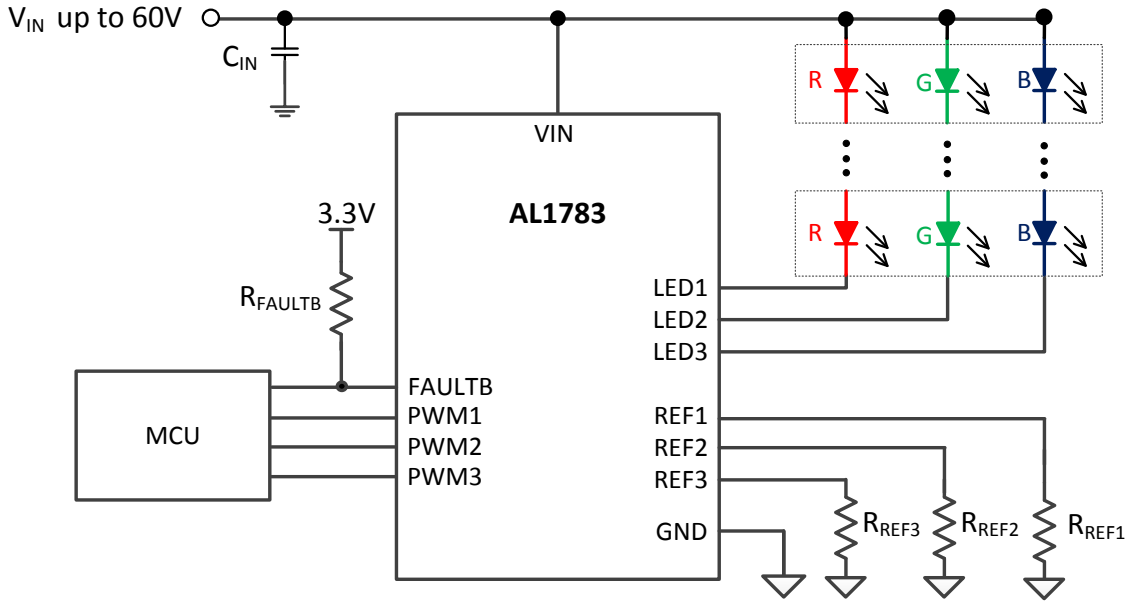

Figure 1. Typical Application

Pin Descriptions

Pin Number	Pin Name	Function
VIN	1	Power Supply for Chip
NC	2	No Connection
PWM1	3	PWM Dimming Signal and Enable Input for 1 st channel of LED1, Internally Pulled Down 200KΩ typical.
PWM2	4	PWM Dimming Signal and Enable Input for 2 nd channel of LED2, Internally Pulled Down 200KΩ typical.
PWM3	5	PWM Dimming Signal and Enable Input for 3 rd channel of LED3, Internally Pulled Down 200KΩ typical.
GND	6	Ground
GND	7	Ground
GND	8	Ground
LED3	9	3 rd Channel for LED String Cathode
LED2	10	2 nd Channel for LED String Cathode
LED1	11	1 st Channel for LED String Cathode
NC	12	No Connection
FAULTB	13	Fault Report. Open Drain Asserted Low to report faulty conditions. Needs an external pull-up resistor.
REF3	14	Reference Current Setting through External Resistor (R_{REF3})
REF2	15	Reference Current Setting through External Resistor (R_{REF2})
REF1	16	Reference Current Setting through External Resistor (R_{REF1})
—	Exposed PAD	Exposed pad must connect to GND. It should be externally connected to GND to reduce thermal impedance. It should not be used as an electrical conduction path.

Functional Block Diagram

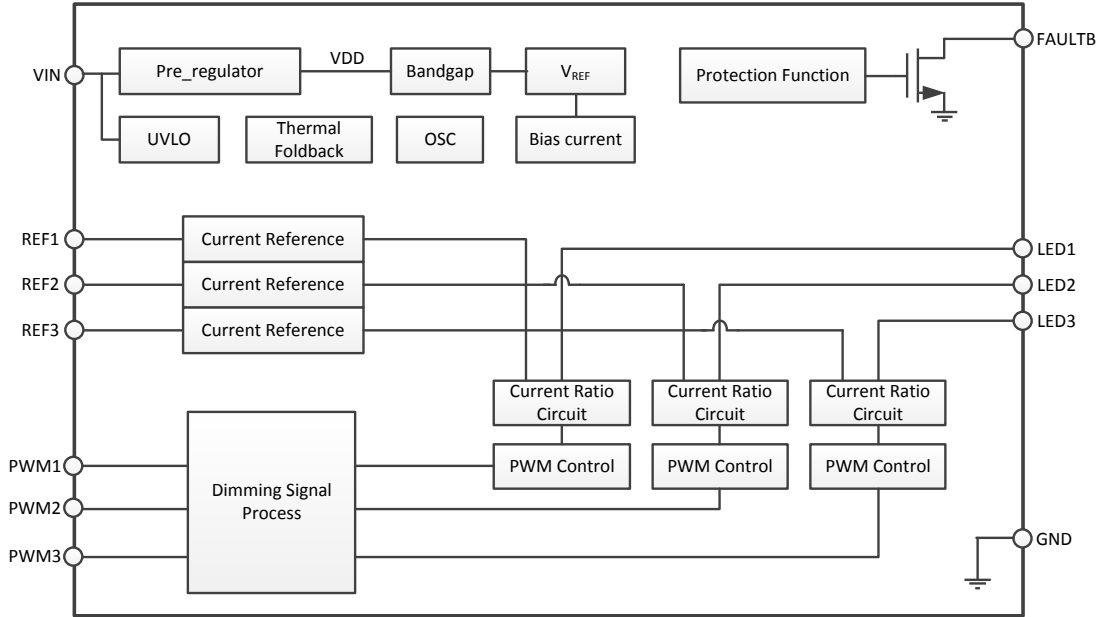

Figure 2. Functional Block Diagram

Absolute Maximum Ratings (Note 4)

Symbol	Parameter	Ratings	Units
V_{VIN}	Input Voltage Relative to GND	-0.3 to 65	V
$V_{LED1,2,3}$	LED1,2,3 Voltage Relative to GND	-0.3 to 65	V
$I_{LED1,2,3}$	LED1,2,3 Output Current	300	mA
$V_{PWM1,2,3}, V_{REF1,2,3}, V_{FAULTB}$	PWM1,2,3, REF1,2,3, and FAULT Voltage Relative to GND	-0.3 to 7	V
T_J	Operating Junction Temperature	-40 to +150	°C
T_{ST}	Storage Temperature	-55 to +160	°C

Notes: 4. Stresses greater than the 'Absolute Maximum Ratings' specified above, may cause permanent damage to the device. These are stress ratings only; functional operation of the device at these or any other conditions exceeding those indicated in this specification is not implied. Device reliability may be affected by exposure to absolute maximum rating conditions for extended periods of time. Semiconductor devices are ESD sensitive and may be damaged by exposure to ESD events. Suitable ESD precautions should be taken when handling and transporting these devices

ESD Ratings

Symbol	Parameter	Rating	Unit
V_{ESD}	Human-Body Model (HBM)	+/-2000	V
	Charged-Device Model (CDM)	+/-1000	

Recommended Operating Conditions

Symbol	Parameter	Min	Max	Unit
V_{VIN}	Input Voltage Relative to GND	6.5	60	V
V_{IH}	High-Level Input Voltage on PWM1,2,3	1.4	5.5	V
V_{IL}	Low-Level Input Voltage on PWM1,2,3	0	0.4	V
T_J	Operating Junction Temperature Range	-40	+125	°C
T_A	Operating Ambient Temperature	-40	+105	°C

Thermal Information (Note 5)

Symbol	Parameter	Rating	Unit
θ_{JA}	Junction-To-Ambient Thermal Resistance	45	°C/W
θ_{JC}	Junction-To-Case (Top) Thermal Resistance	10	°C/W

Notes: 5. Device mounted on 2" x 2" FR-4 substrate PCB, 2oz copper, with minimum recommended pad on top layer and thermal vias to bottom layer ground plane.

Electrical Characteristics (@ $T_A = +25^\circ\text{C}$, $V_{IN} = +12\text{V}$, unless otherwise specified.)

Symbol	Parameter	Test Conditions	Min	Typ	Max	Unit
V_{VIN_UVLO}	VIN UVLO Voltage	$V_{PWM1,2,3} = 0\text{V}$, V_{VIN} Rising	—	5.8	—	V
$V_{VIN_UVLO_HYS}$	VIN UVLO Hysteresis	$V_{PWM1,2,3} = 0\text{V}$, V_{VIN} Falling	—	300	—	mV
$I_{VIN_Standby}$	Input current in Standby Mode	Standby Mode, all PWM1,2,3 are "L" for 4ms	—	200	—	μA
I_{bVCC_Q}	Input Current in Normal Mode	Enabled, LED1,2,3 floating, any PWM1,2,3 is "H", $R_{REF1,2,3}$ is 48K Ω	—	1.5	—	mA
$V_{IL_PWM1,2,3}$	PWM Low Voltage	—	—	—	0.4	V
$V_{IH_PWM1,2,3}$	PWM High Voltage	—	1.4	—	—	V
$F_{PWM1,2,3}$	PWM Frequency	—	0.5	—	40	kHz
$I_{PWM1,2,3_PD}$	PWM Internal Pulldown	$V_{PWM1,2,3} = 5\text{V}$	0.35	—	3.5	μA
$T_{PWM1,2,3_MIN_ON}$	Minimum PWM1,2,3 On Time	—	10	—	—	μs
$T_{PWM1,2,3_SHDN}$	Entrance time for Standby Mode when all PWM1,2,3 are "L"	—	—	4	—	ms
$V_{REF1,2,3}$	Reference Voltage	—	1.47	1.5	1.53	V
$I_{REF1,2,3}$	Reference Current	$R_{REF1,2,3} = 48\text{K}\Omega$	—	31.25	—	μA
$I_{LED1,2,3_NOM}$	Nominal Regulation Current for Channel 1, 2, 3	$R_{REF1,2,3} = 48\text{K}\Omega$	120	125	130	mA
$I_{LED1,2,3_Max}$	Max Regulation Current for Channel 1,2,3	$R_{REF1,2,3} = 24\text{K}\Omega$ (Notes: 6)	—	250	—	mA
$I_{LED1,2,3_Min}$	Min. Regulation Current for Channel 1,2,3	$R_{REF1,2,3} = 200\text{K}\Omega$ (Notes: 6)	—	30	—	mA
$V_{LED1,2,3_REG}$	Minimum LED Regulation Voltage	$I_{LED1,2,3} = 125\text{mA}$	—	0.7	—	V
$I_{LED1,2,3_LEAK}$	LED1,2,3 Leakage Current	$V_{PWM1,2,3} = 0\text{V}$, $V_{LED1,2,3} = +12\text{V}$	—	0.1	—	μA
$V_{LED1,2,3SHP}$	LED Short Protection Threshold	(Note 7)	—	15	—	V
$T_{LED1,2,3SHDG}$	Short-detection Deglitch	100% duty-cycle	—	3	—	ms
$N_{LED1,2,3SHDG}$		PWM Dimming (count the number of continuous cycles when LED short is detected)	—	7	—	Cycles
$T_{LED1,2,3SH_HICCUP}$	LED Short Protection Hiccup Time	—	—	128	—	ms
$T_{LED1,2,3OPDG}$	Open-detection Deglitch	100% duty-cycle	—	3	—	ms
$N_{LED1,2,3OPDG}$		PWM Dimming (count the number of continuous cycles when LED open is detected)	—	7	—	Cycles
$T_{LED1,2,3OP_HICCUP}$	LED Open Protection Hiccup Time	—	—	128	—	ms
T_{SS}	Soft-start Time	$V_{PWM1,2,3} = 5\text{V}$, 90% of $I_{LED1,2,3_NOM}$	—	200	—	μs
V_{FOL}	FAULTB Output Low Voltage	$I_{FAULTB} = 1\text{mA}$	—	—	180	mV
I_{FOH}	FAULTB Leakage Current	$V_{FAULTB} = 5\text{V}$	—	—	1	μA
T_{SHDN}	Thermal Shutdown Threshold	—	—	—	160	$^\circ\text{C}$
T_{REC}	Thermal Recovery Threshold	—	—	—	140	$^\circ\text{C}$

Notes: 6. These parameters, although guaranteed by design, are not 100% tested in production
7. LED short is detected when $V_{LED1,2,3} > 15\text{V}$.

Typical Performance Characteristics ($T_A = +25^\circ\text{C}$, $V_{IN} = 12\text{V}$, $R_{REF}=48\text{k}\Omega$, $I_{LED}=125\text{mA}$ unless otherwise noted).

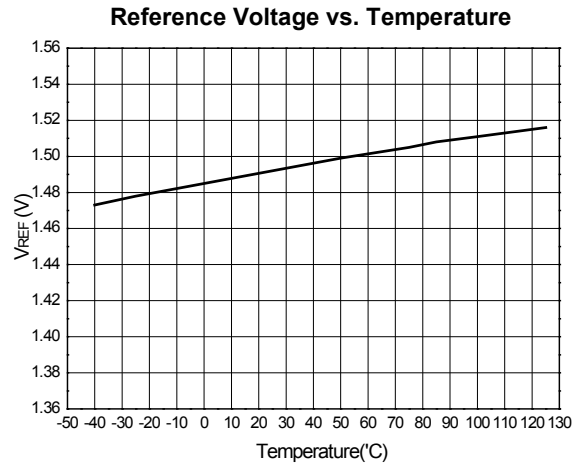
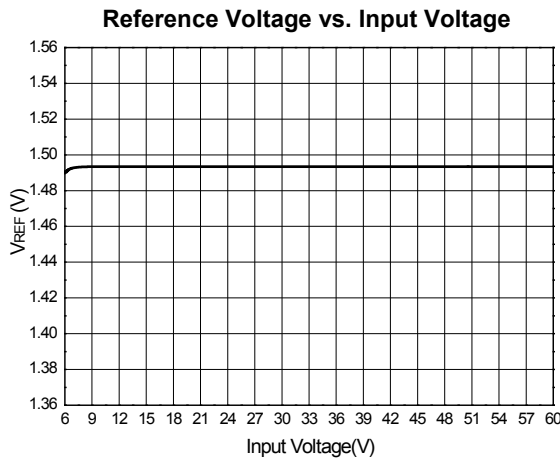
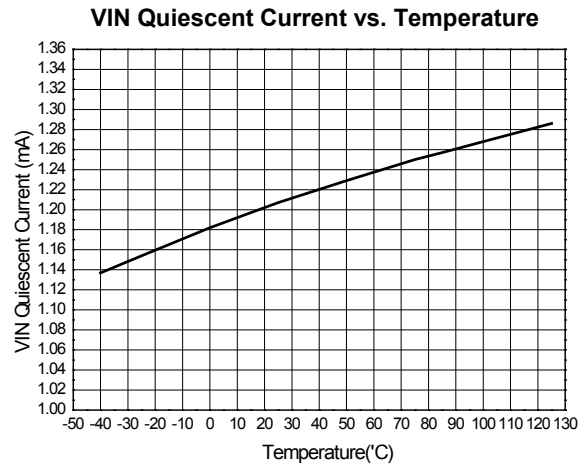
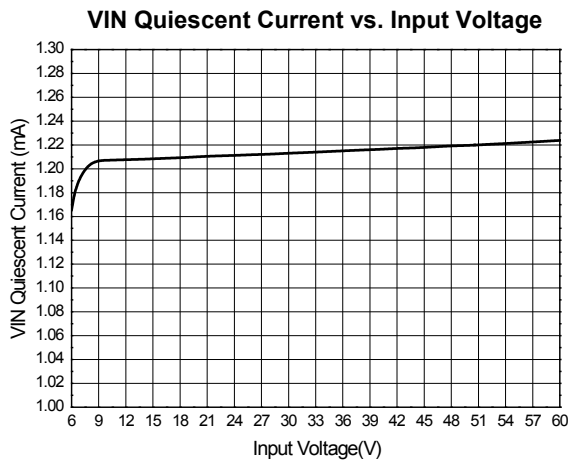
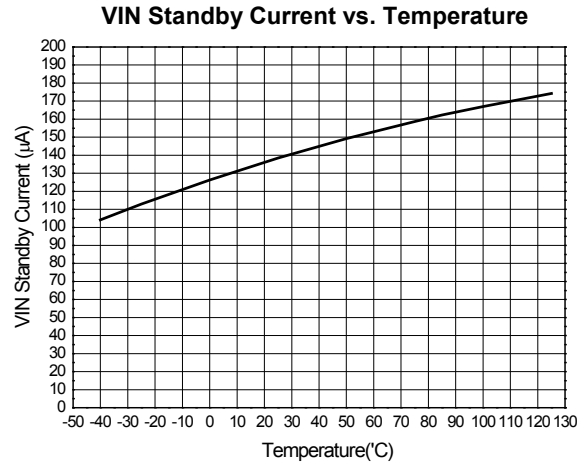
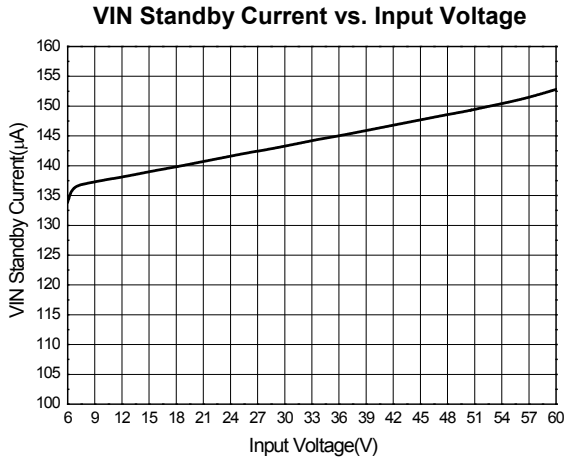

Typical Performance Characteristics ($T_A = +25^\circ\text{C}$, $V_{IN} = 12\text{V}$, $R_{REF} = 48\text{k}\Omega$, $I_{LED} = 125\text{mA}$ unless otherwise noted).

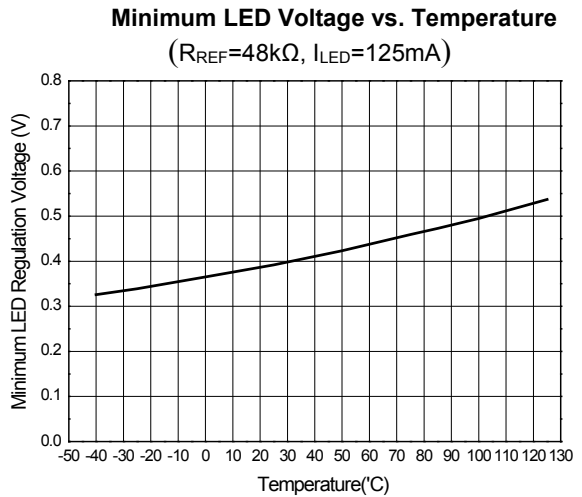
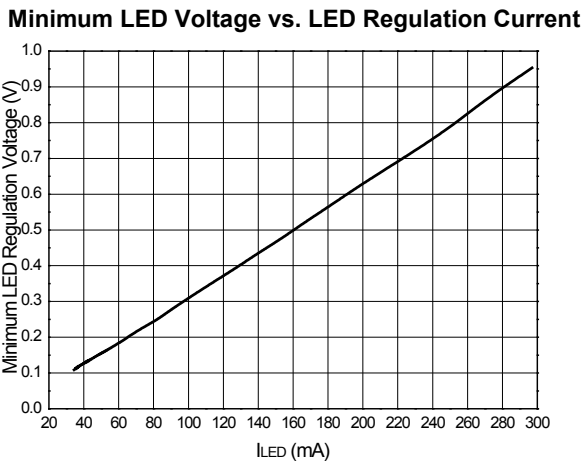
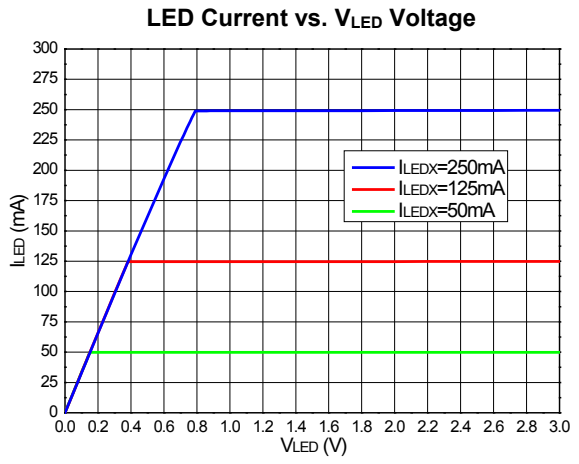
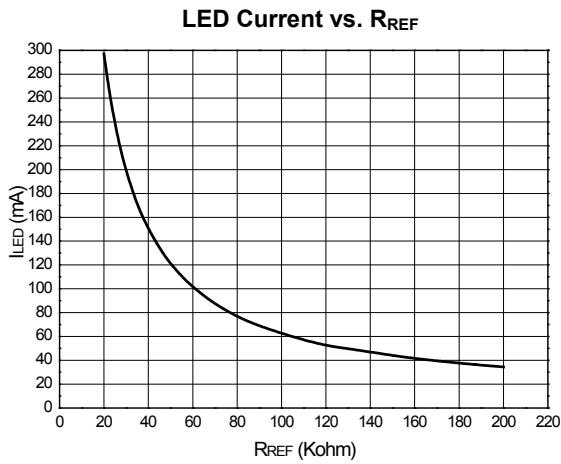
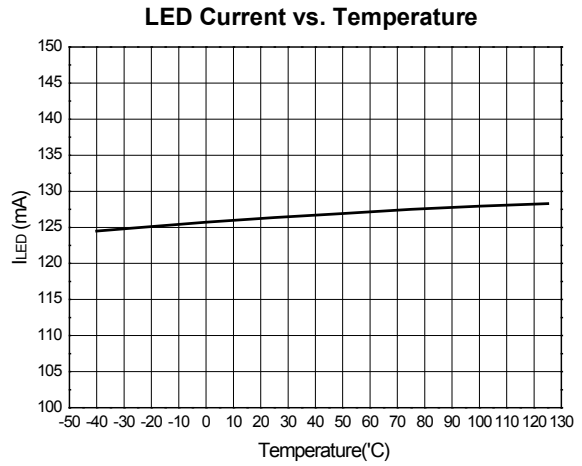
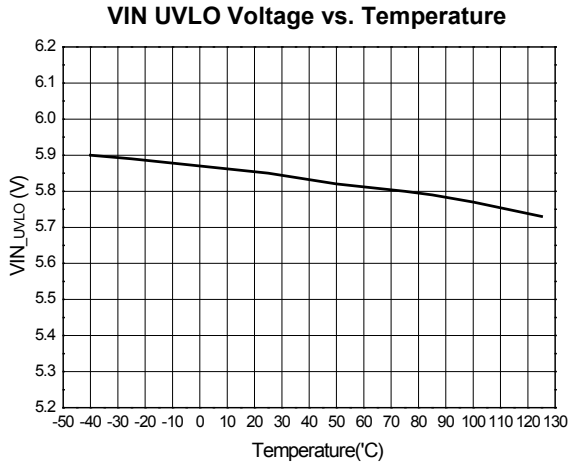

Typical Performance Characteristics ($T_A = +25^\circ\text{C}$, $V_{IN} = 12\text{V}$, $R_{REF} = 48\text{K}\Omega$, $I_{LED} = 125\text{mA}$ unless otherwise noted).

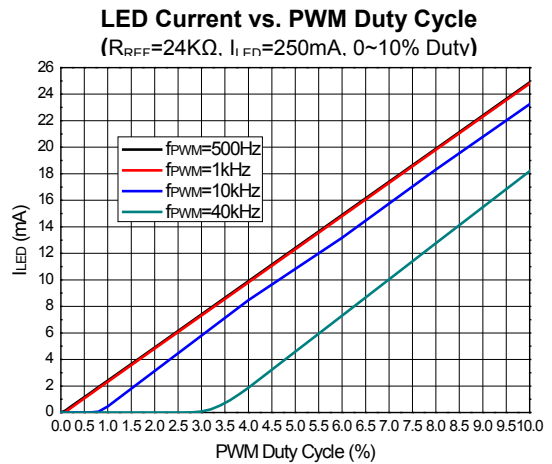
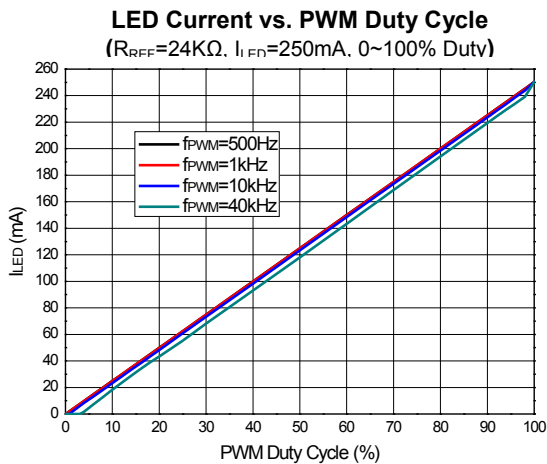
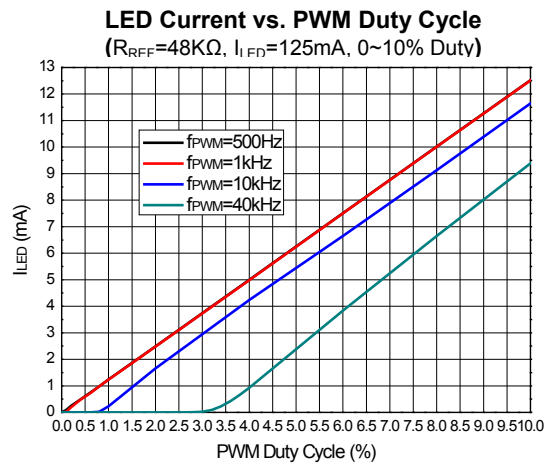
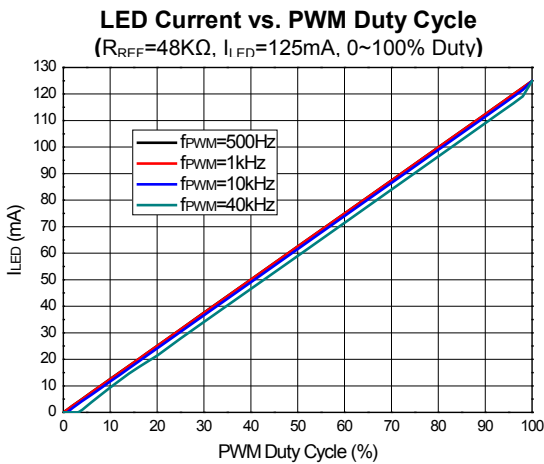
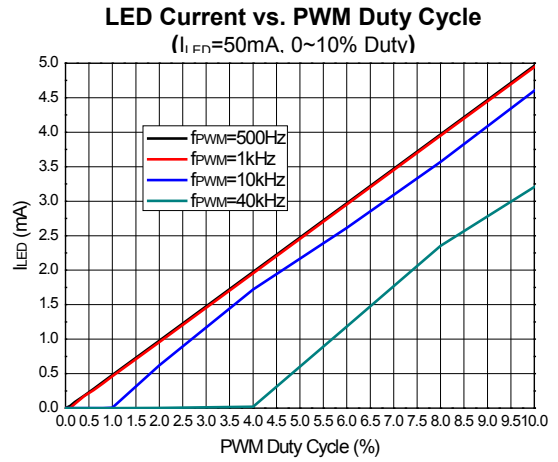
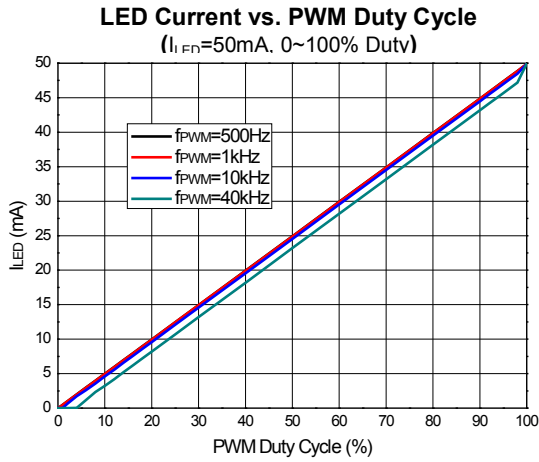

Application Information

Linear LED Driver Design Topology and Implementation

The AL1783 adopts a multi-channel Linear LED driver topology with independent PWM dimming, and current setting control implementation for each channel. The parallel Linear LED driver channel structure associated with the power conversion stage covers mainstream applications for many LED Lighting dimming and color tuning applications. Given the maximum operating input voltage at 60V, it is possible to drive more than 16 RGB emitters by splitting LED Emitter string voltage and VIN, as long as it is below 60V.

The AL1783 is a three PWM current sink regulator. In order to meet channel current accuracy and short protection requirements, the recommended maximum current of each channel is 250mA and the recommended minimum channel current is 30mA. Each channel can be individually and digitally controlled by the PWM dimming the signal down to less than 1% @ 1kHz.

As in the case of three-channel Tunable Color LED lighting, the AL1783 drives three emitter strings. Using R_{REF1} , R_{REF2} , and R_{REF3} of 24K Ω , the maximum output current for Channel 1, Channel 2, and Channel 3 will be 250mA when each PWM signal is turned on. The associated micro-controller unit (MCU) shall program and generate the suitable PWM duty cycle to meet the required and targeted Tuning Color output. R_{REF1} , R_{REF2} , and R_{REF3} can also be set dynamically for different peak values to achieve the desired channel peak current if another dimension adjustment is needed.

The LED Driving Element detects fault conditions and reports its status on the FAULTB pin. It features LED open detection, LED short detection, Over Temperature Protection (OTP), and Under Voltage Lockout (UVLO). The AL1783 provides supreme current matching between channels and devices. Along with bus-mode fault reporting, multiple devices can be employed together to increase current driving capabilities or channel count versatility.

Interface with Emitter Strings

The Power Conversion stage provides necessary constant output voltages (CVs) to power the micro-controller unit (MCU), LED Strings, and LED Drivers. A typical application requires 3.3V for the MCU and 12V/24V/48V anodes of LED emitter strings. The cathodes of the bottom LED emitter strings are connected to the LED1,2,3 pins of the AL1783.

Interface with MCU

The physical layer interfaces between the micro-controller unit (MCU) and the AL1783 are the PWM1,2,3 pins and FAULTB. The MCU activates the PWM1,2,3 (asserted high) to turn on AL1783 during normal LED lighting operation applications. When the PWM1,2,3 pins are asserted low and greater than > 4ms, the device enters into Standby Mode with minimum power consumption. For typical light dimming or mixing operations, the MCU generates proper dimming control output signals to the PWM1,2,3 pins. If any general fault occurs in the AL1783, the FAULTB pin is asserted LOW to interrupt and request the MCU to take proper actions.

Application Information (cont.)

Current Setting

The AL1783 is designed to have individual LED channel currents set by its corresponding current setting from the $R_{SET1,2,3}$ resistor. The LED channel current level is expressed as below:

$$I_{LED1,2,3} = 4000 * \frac{V_{REF}}{R_{SET1,2,3}}$$

where $V_{REF} = 1.5V$ nominally for all channels

For example, when an R_{REF} of $24K\Omega$ is used, each channel of the AL1783 provides the same output current of 250mA.

The maximum LED current for each channel can be adjusted up to 250mA via the R_{REF} resistor for AL1783. Any two or more channels can be tied together to drive one LED string with aggregated current. So when the current needed for any channel is greater than the maximum value the device can provide, two or more channels or devices can be connected and paralleled together to provide the higher drive current necessary.

Support Higher Current

While the recommended maximum operating current is at 250mA for each channel, and total 750mA for the AL1783, by setting R_{REF1} , R_{REF2} , and R_{REF3} at $24K\Omega$; the system design can drive an LED string with higher current by connecting the cathodes of the LED emitter string to two or more LED channel outputs (LED1,2,3) and tie the associated PWM pins (PWM1,2,3) to the same PWM signal from the MCU. The total current through the LED emitter string is the sum of the current through each individual channel.

Similarly, it is also possible to further increase the current for a specific LED string by connecting two or more AL1783 IC chips in parallel and drive all associated PWM pins with a common PWM signal.

PWM Dimming Control

A PWM frequency greater than 500HZ is recommended. A high level of PWM signals will turn the current sink on to flow through the LED pin, and a low level will turn it off. Consequently, each LED channel and LED brightness of the corresponding channel can be adjusted cycle-by-cycle accordingly.

The pulse width of the PWM signal should be no less than $10\mu s$, supporting down to 1% @ 1 kHz deep dimming capability. PWM signals can be driven static high/low to turn on/off the corresponding channels.

Enable and Soft-Start LED Drivers (EN Pin)

The PWM of the AL1783 is enabled when the voltage at any PWM1,2,3 pin is greater than the typical voltage of 2.5V, and disabled when all PWM1,2,3 are lower than 0.4V. When PWM1,2,3 pin is asserted and the VIN pin is ramped up beyond minimum operation voltage, a soft start will be performed with a slew-rate controlled current ramp over $200\mu s$ at the LED1,2,3 output pins. For optimal system reliability, this minimizes the current overshooting through the LED strings. When all PWM1,2,3 are asserted low for $> 4ms$, the LED Driver will enter into Standby Mode with ultra-low standby power $< 200\mu A$.

Standby Mode

When in this Standby Mode, the power consumption saved is $I_{vin_standby}$ (Standby Power Supply Current) * VIN (VIN for LED driver circuit). Refer to the case of the R_{REF} at $24K\Omega$ (for 250mA channel current in the AL1783, $I_{standby}$ is typical at 0.2mA) and VIN is 50V, or 10mW for the LED driver portion.

When any PWM signal driving AL1783 is detected, the AL1783 will automatically exit the standby mode and perform the designated functions properly.

Application Information (cont.)

Fault Reporting (FAULTB Pin)

The AL1783 detects and reports the FAULTB status upon the occurrence of Thermal Shutdown in OTP, LED Short, LED Open, and UVLO. The FAULTB pin is an open-drain output design. Multiple devices can share a single FAULTB signal by connecting all FAULTB pins together with an external pull-up resistor.

Under Voltage Lockout (Hysteresis Mode)

Under-voltage lockout function (UVLO) guarantees that the device is initially off during start-up. The AL1783 is not turned ON until the power supply has reached 6V. Whenever the input voltage falls below approximately 5.7V, the device is turned off and the FAULTB status will be reported. The UVLO detection-trigger circuitry has a hysteresis of 300mV.

LED Open Protection (Hiccup Mode)

The AL1783 detects the LED status by monitoring the current of the LED pin. When LED opens and lasts for a period of time period, the AL1783 enters protection mode and shuts down all channels. The time period is 7 cycles of the input PWM signal or 3ms timer when the PWM duty is 100%. The abnormal channel will be retested afterward to check if the abnormal condition is cleared. The AL1783 periodically checks every 128ms if the abnormal condition is removed. The LED driver will re-activate once the abnormal condition is cleared. The LED open protection is effective when the input PWM1,2,3 signal on time is higher than 10µs, or 1% @ 1 kHz. The FAULTB pin will be asserted low when the LED pin detects that the LED string is open, and will resume high once the LED open condition is removed.

LED Short Protection (Hiccup Mode)

The AL1783 detects the LED status by monitoring voltage at the LED1,2,3 pins. When the LED string anode is short to cathode, $V_{LED1,2,3}$ will be pulled up. When $V_{LED1,2,3}$ voltage exceeds 15V and lasts for a short time period, the AL1783 enters protection mode and shuts down all channels. The time period is 7 cycles of the input PWM signal or 3ms timer when the PWM duty is 100%. The abnormal channel will be periodically rechecked every 128ms afterward to detect if the abnormal condition is cleared. The LED driver will re-activate once the abnormal condition is cleared. The LED short protection is effective when the input voltage is higher than 15V and the input PWM1,2,3 signal on time is higher than 10µs, or 1% @ 1 kHz. The FAULTB pin will be asserted low when the LED shorts, and will resume high once the LED short condition is removed.

Thermal Foldback and Over Temperature Protection (Hysteresis Mode)

Temperature is a concern when driving the LEDs at high currents. Take care at high temperatures so as to not exceed the LED operating temperature requirements. In order to cool down the LEDs before they are damaged, the current going through the LEDs must be decreased when the LED temperature begins to increase.

When the chip temperature is higher than the threshold temperature (130°C), the AL1783 starts to reduce the V_{REFX} voltage and the LED current starts to fall from the nominal current. As illustrated in Figure 3, the LED current decreases as the temperature increases.

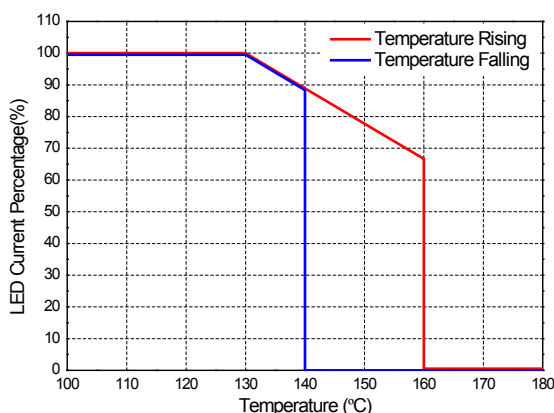
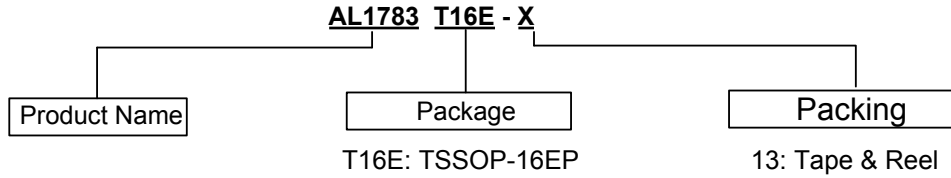

Figure 3. Thermal Fold-back Diagram

Thermal protection prevents the IC from being damaged when the temperature exceeds safe margins. When the junction temperature reaches 160°C, the device will enter thermal shut down, and all currents will sink and while no current flows to the LED strings. The normal current level can be automatically restored to its set current from OTP by triggering a Soft Start once the temperature cools down below 140°C. The LED Driver’s Thermal Shut Mode will also be reported at the FAULTB pin.

Ordering Information



Part Number	Package Code	Packaging	13" Tape and Reel	
			Quantity	Part Number Suffix
AL1783T16E-13	T16E	TSSOP-16EP (Type DX) (Note 8)	2500/Tape & Reel	-13

Note: 8. For packaging details, go to our website at <http://www.diodes.com/products/packages.html>

Marking Information

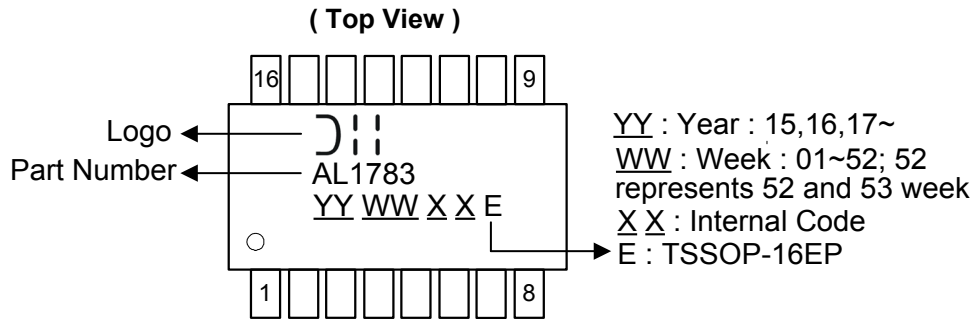

Package Outline Dimensions (All dimensions in mm.)

Please see <http://www.diodes.com/package-outlines.html> for the latest version.

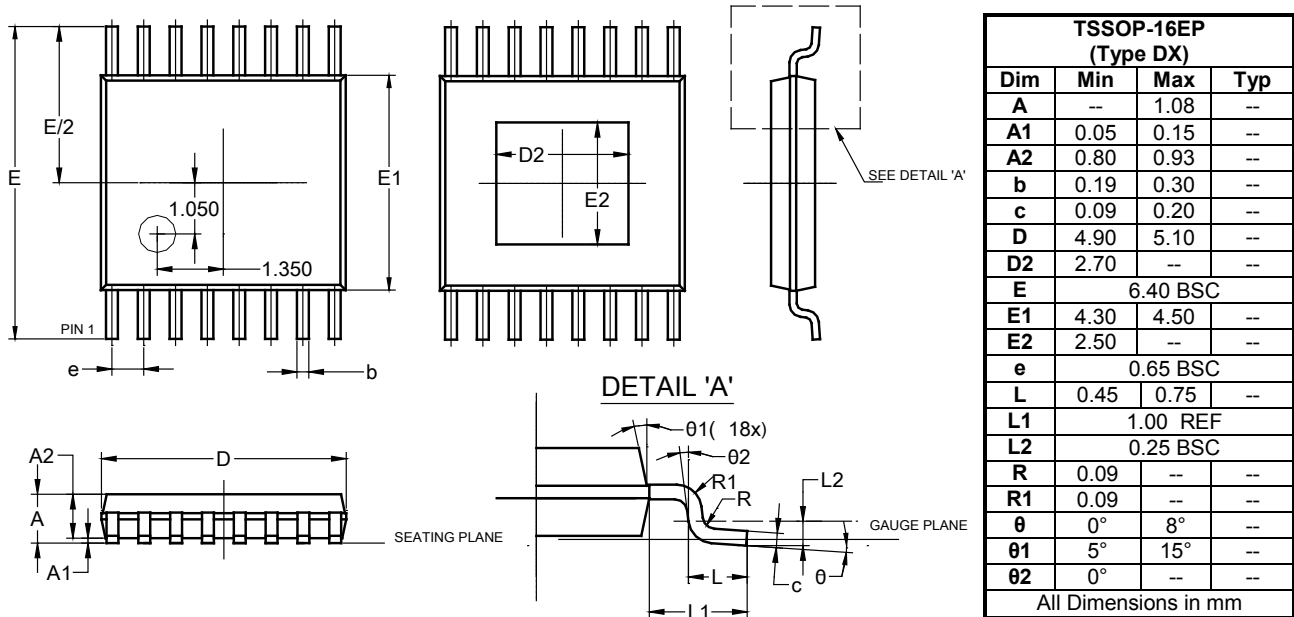

Suggested Pad Layout

Please see <http://www.diodes.com/package-outlines.html> for the latest version.

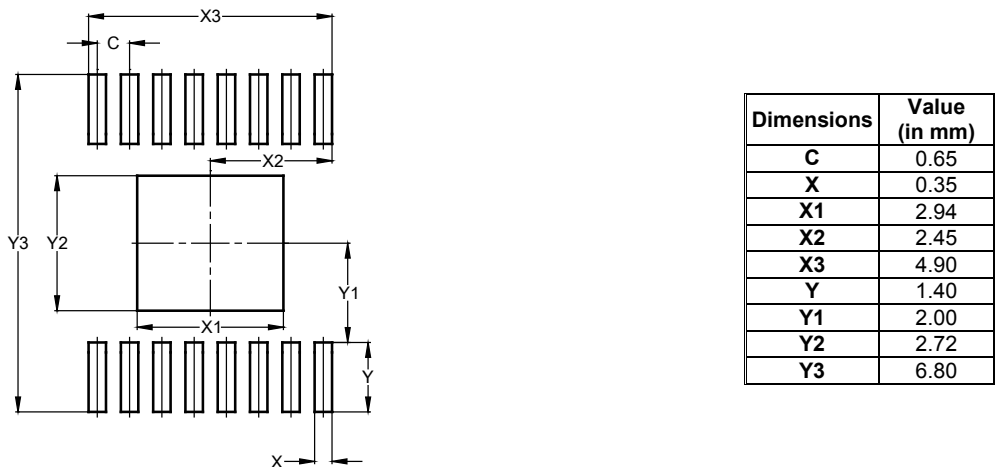

Mechanical Data

- Moisture Sensitivity: MSL Level 1 per J-STD-020
- Terminals: Finish - Matte Tin Plated Leads, Solderable per JESD22-B102 ③
- Weight: 0.056 grams (Approximate)

IMPORTANT NOTICE

1. DIODES INCORPORATED AND ITS SUBSIDIARIES (“DIODES”) MAKE NO WARRANTY OF ANY KIND, EXPRESS OR IMPLIED, WITH REGARDS TO ANY INFORMATION CONTAINED IN THIS DOCUMENT, INCLUDING, BUT NOT LIMITED TO, THE IMPLIED WARRANTIES OF MERCHANTABILITY, FITNESS FOR A PARTICULAR PURPOSE OR NON-INFRINGEMENT OF THIRD PARTY INTELLECTUAL PROPERTY RIGHTS (AND THEIR EQUIVALENTS UNDER THE LAWS OF ANY JURISDICTION).
2. The Information contained herein is for informational purpose only and is provided only to illustrate the operation of Diodes products described herein and application examples. Diodes does not assume any liability arising out of the application or use of this document or any product described herein. This document is intended for skilled and technically trained engineering customers and users who design with Diodes products. Diodes products may be used to facilitate safety-related applications; however, in all instances customers and users are responsible for (a) selecting the appropriate Diodes products for their applications, (b) evaluating the suitability of the Diodes products for their intended applications, (c) ensuring their applications, which incorporate Diodes products, comply the applicable legal and regulatory requirements as well as safety and functional-safety related standards, and (d) ensuring they design with appropriate safeguards (including testing, validation, quality control techniques, redundancy, malfunction prevention, and appropriate treatment for aging degradation) to minimize the risks associated with their applications.
3. Diodes assumes no liability for any application-related information, support, assistance or feedback that may be provided by Diodes from time to time. Any customer or user of this document or products described herein will assume all risks and liabilities associated with such use, and will hold Diodes and all companies whose products are represented herein or on Diodes’ websites, harmless against all damages and liabilities.
4. Products described herein may be covered by one or more United States, international or foreign patents and pending patent applications. Product names and markings noted herein may also be covered by one or more United States, international or foreign trademarks and trademark applications. Diodes does not convey any license under any of its intellectual property rights or the rights of any third parties (including third parties whose products and services may be described in this document or on Diodes’ website) under this document.
5. Diodes products are provided subject to Diodes’ Standard Terms and Conditions of Sale (<https://www.diodes.com/about/company/terms-and-conditions/terms-and-conditions-of-sales/>) or other applicable terms. This document does not alter or expand the applicable warranties provided by Diodes. Diodes does not warrant or accept any liability whatsoever in respect of any products purchased through unauthorized sales channel.
6. Diodes products and technology may not be used for or incorporated into any products or systems whose manufacture, use or sale is prohibited under any applicable laws and regulations. Should customers or users use Diodes products in contravention of any applicable laws or regulations, or for any unintended or unauthorized application, customers and users will (a) be solely responsible for any damages, losses or penalties arising in connection therewith or as a result thereof, and (b) indemnify and hold Diodes and its representatives and agents harmless against any and all claims, damages, expenses, and attorney fees arising out of, directly or indirectly, any claim relating to any noncompliance with the applicable laws and regulations, as well as any unintended or unauthorized application.
7. While efforts have been made to ensure the information contained in this document is accurate, complete and current, it may contain technical inaccuracies, omissions and typographical errors. Diodes does not warrant that information contained in this document is error-free and Diodes is under no obligation to update or otherwise correct this information. Notwithstanding the foregoing, Diodes reserves the right to make modifications, enhancements, improvements, corrections or other changes without further notice to this document and any product described herein. This document is written in English but may be translated into multiple languages for reference. Only the English version of this document is the final and determinative format released by Diodes.
8. Any unauthorized copying, modification, distribution, transmission, display or other use of this document (or any portion hereof) is prohibited. Diodes assumes no responsibility for any losses incurred by the customers or users or any third parties arising from any such unauthorized use.

Copyright © 2020 Diodes Incorporated

www.diodes.com

Looking for pricing, stock, or lifecycle information?

Click below to explore more details on WIN SOURCE:

 [View AL1783T16E-13 on WIN SOURCE](#)

 [Diodes Incorporated](#) Information

Optimize Your Supply Chain with WIN SOURCE Solutions

-  Global Sourcing Solution
-  Obsolete Management
-  Cost Control Management
-  Shortage Management
-  Alternative Solution
-  Excess Inventory Management