



**THE DATASHEET OF
DGD0227S8-13**



Description

The DIODES™ DGD0227 dual, high-speed, low-side MOSFET and IGBT driver is capable of driving 4A of peak current. The DGD0227 logic inputs are compatible with standard TTL and CMOS levels (down to 3.3V) to interface easily with MCUs. Fast and well-matched propagation delays allow high-speed operation, enabling a smaller, more compact power-switching design using smaller associated components.

The DGD0227 is offered in the SO-8 (Type TH) package and operates over an extended -40°C to +125°C temperature range.

Features

- Efficient Low Cost Solution for Driving MOSFETs and IGBTs
- Wide Supply Voltage Operating Range: 4.5V to 18V
- 4.0A Source/4.0A Sink Output Current Capability
- Fast Propagation Delay (35ns Typ)
- Fast Rise and Fall Times (20ns Typ)
- Logic Input (IN) 3.3V Capability
- Extended Temperature Range: -40°C to +125°C
- **Totally Lead-Free & Fully RoHS Compliant (Notes 1 & 2)**
- **Halogen and Antimony Free. “Green” Device (Note 3)**
- **For automotive applications requiring specific change control (i.e. parts qualified to AEC-Q100/101/104/200, PPAP capable, and manufactured in IATF 16949 certified facilities), please [contact us](mailto:contact@diodes.com) or your local Diodes representative. <https://www.diodes.com/quality/product-definitions/>**

Applications

- DC-DC converters
- Line drivers
- Motor controls
- Switch mode power supplies

Mechanical Data

- Package: SO-8
- Package Material: Molded Plastic. “Green” Molding Compound. UL Flammability Classification Rating 94V-0
- Moisture Sensitivity: Level 3 per J-STD-020
- Terminals: Finish – Matte Tin Plated Leads Solderable per MIL-STD-202, Method 208 (E3)
- Weight: 0.075 grams (Approximate)

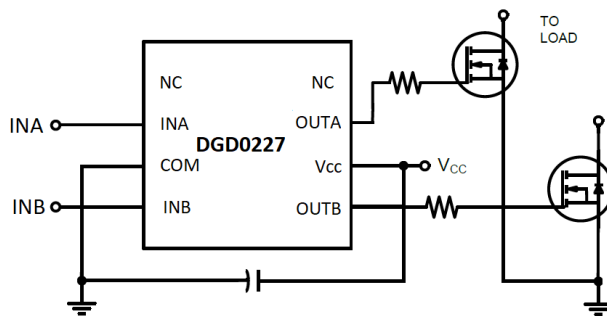

Typical Configuration

SO-8 (Type TH)



Top View

Ordering Information (Note 4)

| Part Number | Package | Marking | Reel Size (inches) | Tape Width (mm) | Packing | |
|--------------|----------------|---------|--------------------|-----------------|---------|---------|
| | | | | | Qty. | Carrier |
| DGD0227S8-13 | SO-8 (Type TH) | DGD0227 | 13 | 12 | 2,500 | Reel |

- Notes:
1. No purposely added lead. Fully EU Directive 2002/95/EC (RoHS), 2011/65/EU (RoHS 2) & 2015/863/EU (RoHS 3) compliant.
 2. See <https://www.diodes.com/quality/lead-free/> for more information about Diodes Incorporated's definitions of Halogen- and Antimony-free, "Green" and Lead-free.
 3. Halogen- and Antimony-free "Green" products are defined as those which contain <900ppm bromine, <900ppm chlorine (<1500ppm total Br + Cl) and <1000ppm antimony compounds.
 4. For packaging details, go to our website at <https://www.diodes.com/design/support/packaging/diodes-packaging/>.

Marking Information



DII = Manufacturer's Marking
 DGD0227 = Product Type Marking Code
 YY = Year (ex: 23 = 2023)
 WW = Week (01 to 53)

Pin Diagram

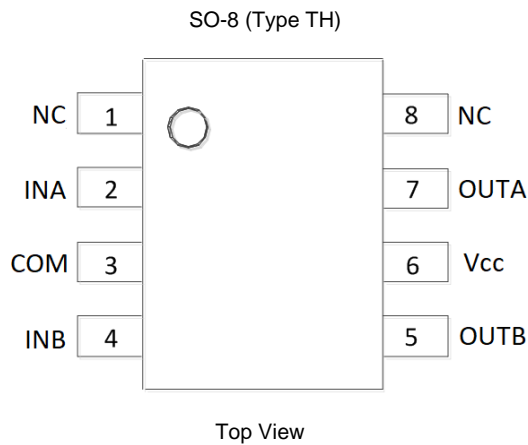

Pin Descriptions

| Pin Number | Pin Name | Function |
|------------|----------|---|
| 1, 8 | NC | No Connection (No Internal Connection) |
| 2 | INA | Logic Input for A Phase, in Phase with OUTA |
| 3 | COM | Supply Return |
| 4 | INB | Logic Input for B Phase, in Phase with OUTB |
| 5 | OUTB | Gate Driver Output B Phase |
| 6 | Vcc | Supply Input |
| 7 | OUTA | Gate Driver Output A Phase |

Functional Block Diagram

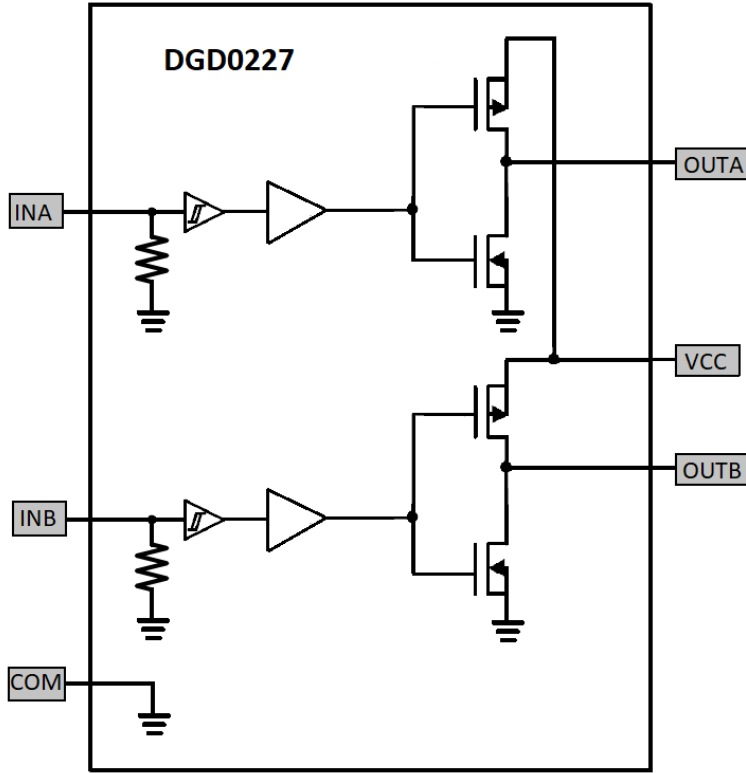

Absolute Maximum Ratings (Note 5) (@T_A = +25°C, unless otherwise specified.)

| Characteristic | Symbol | Value | Unit |
|--------------------------------|------------------|------------------------------|------|
| Low-Side Fixed Supply Voltage | V _{CC} | -0.3 to +22 | V |
| Output Voltage (OUTA, OUTB) | V _{OUT} | -0.3 to V _{CC} +0.3 | V |
| Logic Input Voltage (INA, INB) | V _{IN} | -0.3 to V _{CC} +0.3 | V |

Note: 5. Stresses greater than those listed under *Absolute Maximum Ratings* can cause permanent damage to the device. These are stress ratings only, and functional operation of the device at these or any other conditions beyond those indicated under *Recommended Operating Conditions* is not implied. Exposure to *Absolute Maximum Ratings* for extended periods can affect device reliability.

Thermal Characteristics (@T_A = +25°C, unless otherwise specified.)

| Characteristic | Symbol | Value | Unit |
|---|------------------|-------------|------|
| Power Dissipation Linear Derating Factor (Note 6) | P _D | 0.625 | W |
| Thermal Resistance, Junction to Ambient (Note 6) | R _{θJA} | 200 | °C/W |
| Operating Temperature | T _J | +150 | °C |
| Storage Temperature Range | T _{STG} | -55 to +150 | |

Note: 6. When mounted on a standard JEDEC 2-layer FR-4 board.

ESD Ratings (Note 7)

| Characteristic | Symbol | Value | Unit | JEDEC Class |
|---|---------|-------|------|-------------|
| Electrostatic Discharge – Human Body Model | ESD HBM | 2,000 | V | 2 |
| Electrostatic Discharge – Charge Device Model | ESD CDM | 750 | V | III |

Note: 7. Refer to JEDEC specification JESD22-A114 and JESD22-C101.

Recommended Operating Conditions

| Parameter | Symbol | Min | Max | Unit |
|--------------------------------|------------------|-----|-----------------|------|
| Supply Voltage | V _{CC} | 4.5 | 18 | V |
| Output Voltage (OUTA/OUTB) | V _{OUT} | 0 | V _{CC} | V |
| Logic Input Voltage (INA, INB) | V _{IN} | 0 | 5 | V |
| Ambient Temperature | T _A | -40 | +125 | °C |

DC Electrical Characteristics (V_{BIAS} (4.5V < V_{CC} < 18V), @T_A = +25°C, unless otherwise specified.) (Note 8)

| Parameter | Symbol | Min | Typ | Max | Unit | Conditions |
|---|------------------|-----|-----|-----|------|---|
| Logic "1" Input Voltage | V _{IH} | 2.4 | — | — | V | — |
| Logic "0" Input Voltage | V _{IL} | — | — | 0.7 | V | — |
| Logic "1" Input Bias Current | I _{IH+} | — | — | 10 | μA | V _{IN} = 3.3V |
| Logic "0" Input Bias Current | I _{IH-} | — | — | 10 | μA | V _{IN} = 0V |
| High Level Output Voltage, V _{BIAS} - V _O | V _{OH} | — | 30 | 100 | mV | I _{OUT} = -10mA |
| Low Level Output Voltage | V _{OL} | — | 16 | 50 | mV | I _{OUT} = 10mA |
| Quiescent V _{CC} Supply Current | I _{CCQ} | — | 40 | 100 | μA | V _{IN} = 0V or 3.3V |
| Output High Short Circuit Pulsed Current | I _{O+} | — | 4.0 | — | A | V _{CC} = 14V |
| Output Low Short Circuit Pulsed Current | I _{O-} | — | 4.0 | — | A | V _{CC} = 14V |
| Output Resistance, High | R _{OH} | — | 1.5 | — | Ω | I _{OUT} = -10mA, V _{CC} = 14V |
| Output Resistance, Low | R _{OL} | — | 1.0 | — | Ω | I _{OUT} = 10mA, V _{CC} = 14V |

Note: 8. The V_{IN} and I_{IN} parameters are applicable to the logic pins: INA and INB. The V_O and I_O parameters are applicable to the output pins: OUTA and OUTB.

AC Electrical Characteristics (V_{BIAS} (4.5V < V_{CC} < 18V), C_L = 1000pF, @T_A = +25°C, unless otherwise specified.)

| Parameter | Symbol | Min | Typ | Max | Unit | Conditions |
|----------------------------|------------------|-----|-----|-----|------|-----------------------|
| Turn-On Rise Time | t _R | — | 20 | 40 | ns | V _{CC} = 14V |
| Turn-Off Fall Time | t _F | — | 20 | 40 | ns | V _{CC} = 14V |
| Turn-On Propagation Delay | t _{ON} | — | 40 | 100 | ns | V _{CC} = 14V |
| Turn-Off Propagation Delay | t _{OFF} | — | 35 | 50 | ns | V _{CC} = 14V |

Timing Waveforms

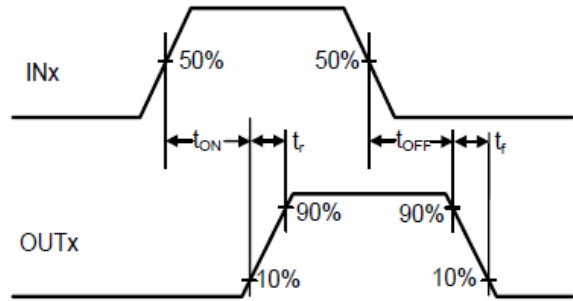

Figure 1. Switching Time Waveform Definitions

Typical Performance Characteristics (@ $T_A = +25^\circ\text{C}$, unless otherwise specified.)

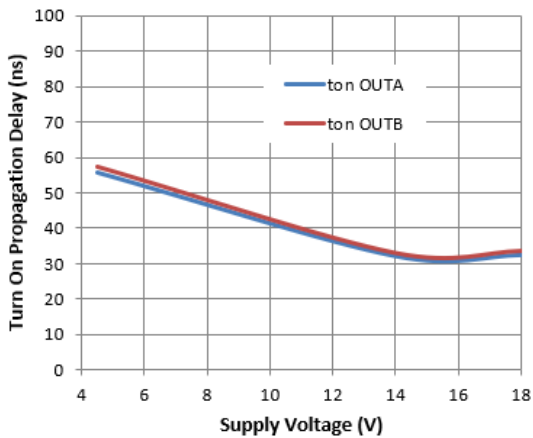

Figure 2. Turn-on Propagation Delay vs. Supply Voltage

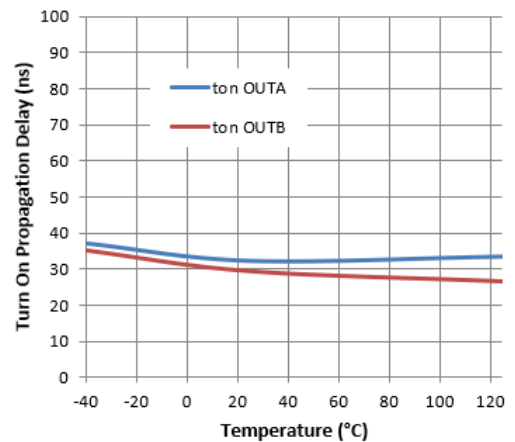

Figure 3. Turn-on Propagation Delay vs. Temperature

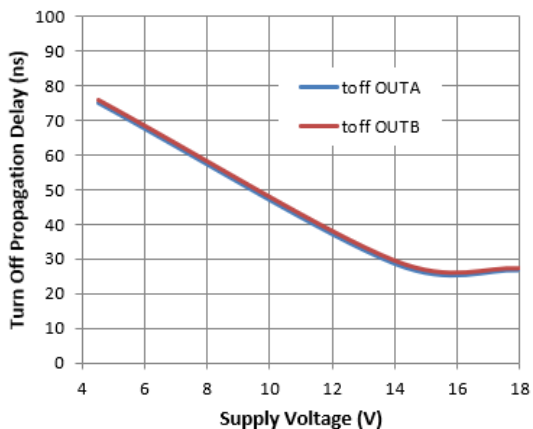

Figure 4. Turn-off Propagation Delay vs. Supply Voltage

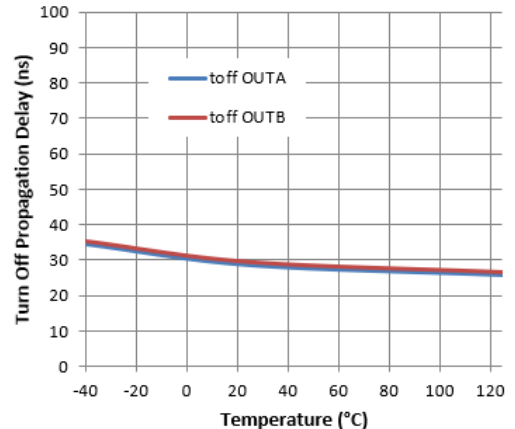

Figure 5. Turn-off Propagation Delay vs. Temperature

Typical Performance Characteristics (@T_A = +25°C, unless otherwise specified.) (continued)

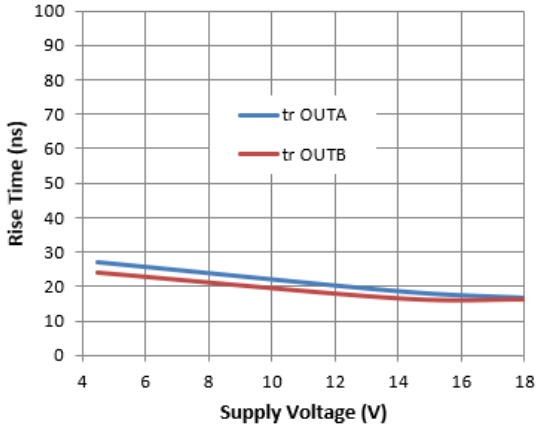

Figure 6. Rise Time vs. Supply Voltage

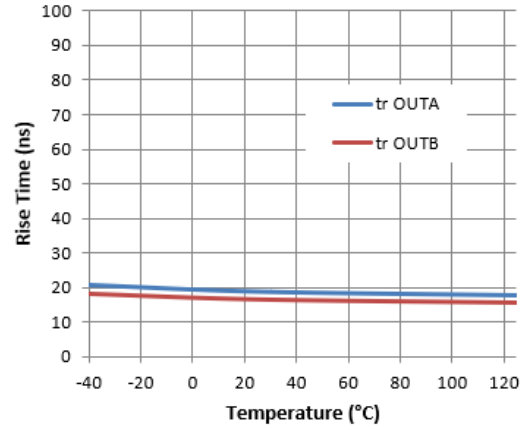

Figure 7. Rise Time vs. Temperature

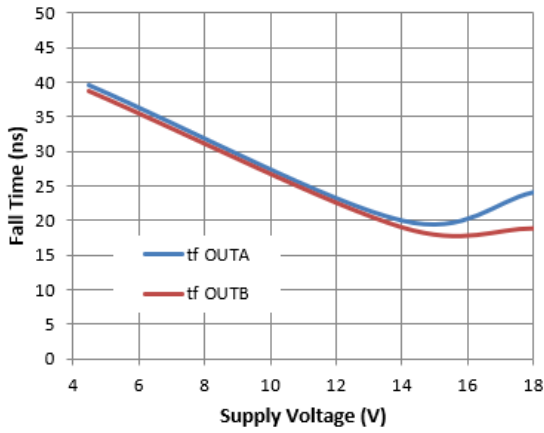

Figure 8. Fall Time vs. Supply Voltage

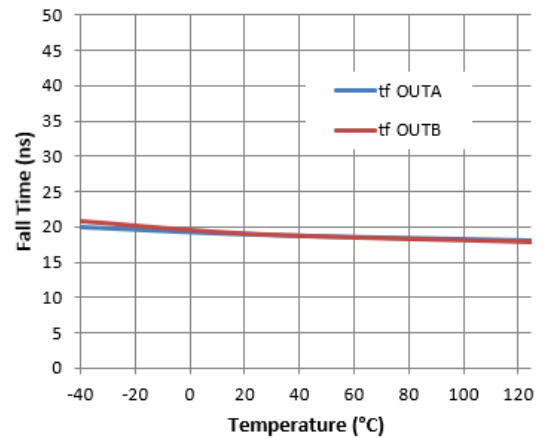

Figure 9. Fall Time vs. Temperature

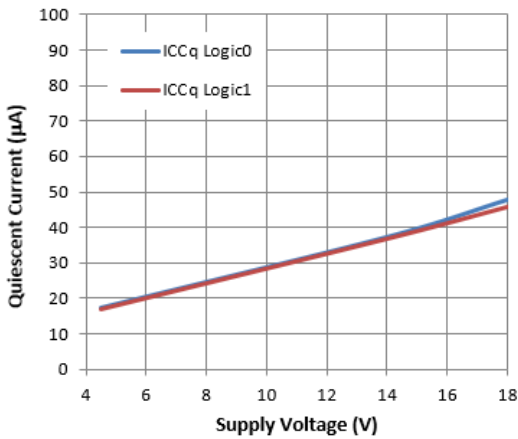

Figure 10. Quiescent Current vs. Supply Voltage

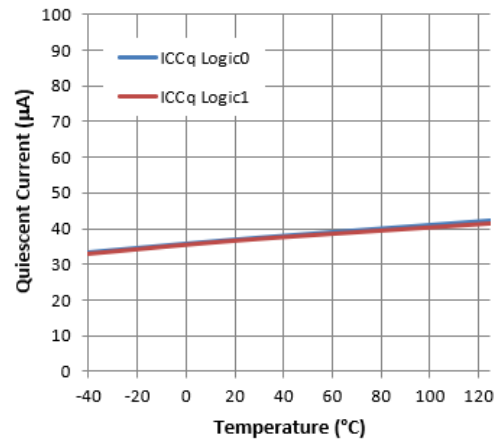

Figure 11. Quiescent Current vs. Temperature

Typical Performance Characteristics (@T_A = +25°C, unless otherwise specified.) (continued)

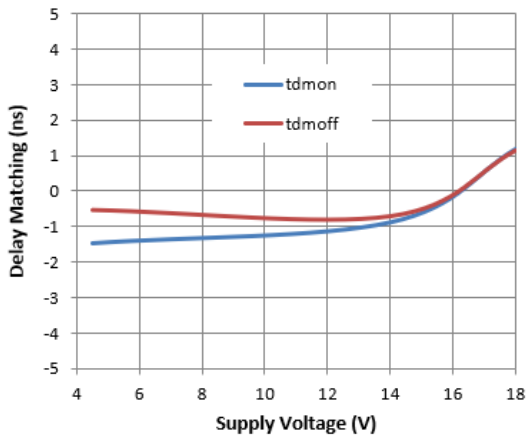

Figure 12. Delay Matching vs. Supply Voltage

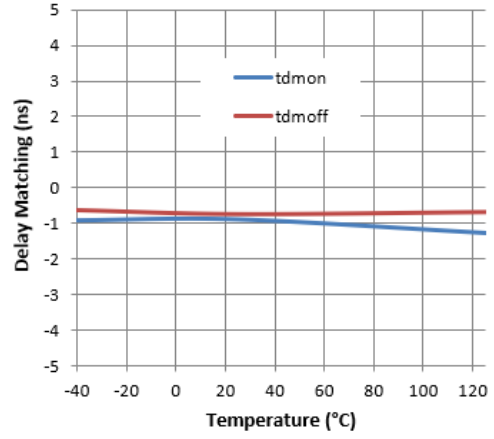

Figure 13. Delay Matching vs. Temperature

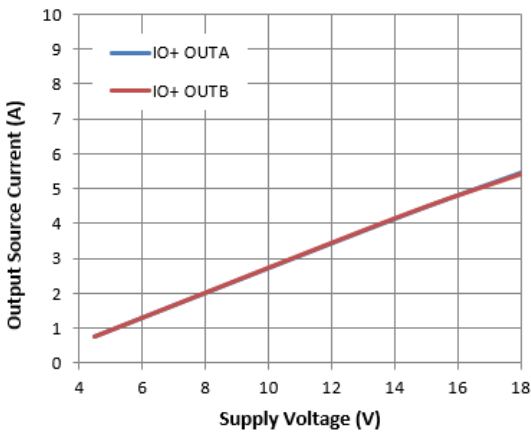

Figure 14. Output Source Current vs. Supply Voltage

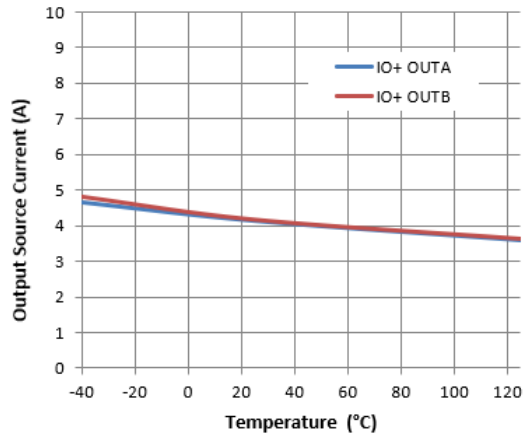

Figure 15. Output Source Current vs. Temperature

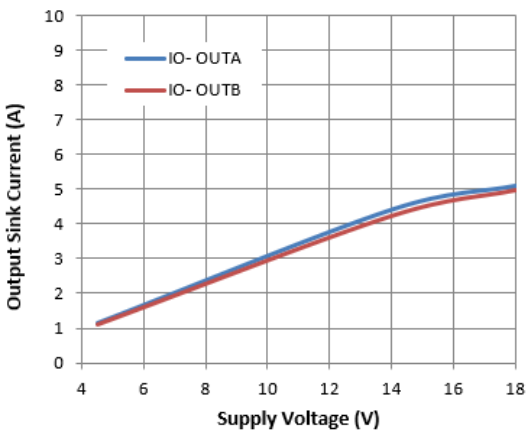

Figure 16. Output Sink Current vs. Supply Voltage

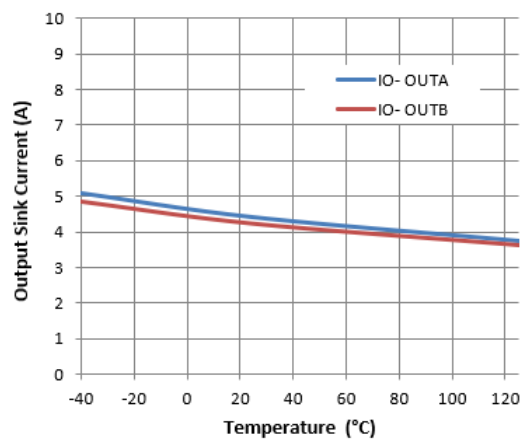

Figure 17. Output Sink Current vs. Temperature

Typical Performance Characteristics (@T_A = +25°C, unless otherwise specified.) (continued)

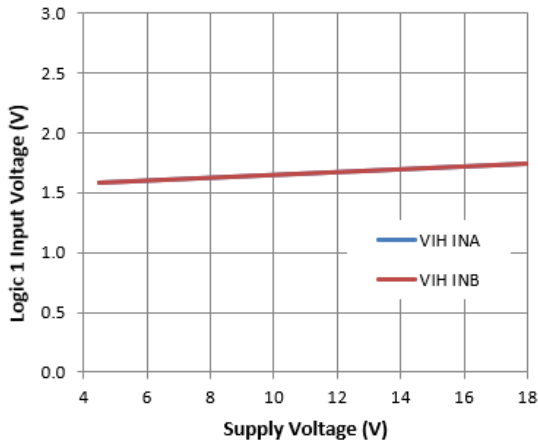

Figure 18. Logic 1 Input Voltage vs. Supply Voltage

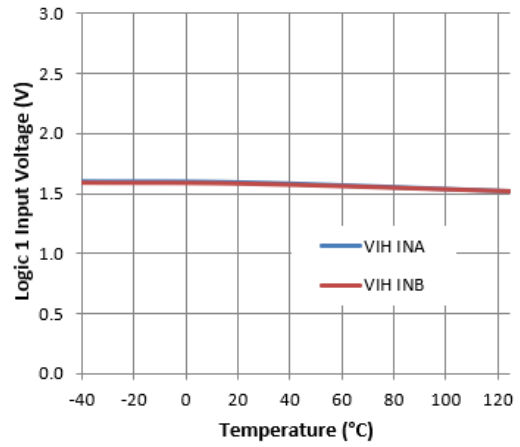

Figure 19. Logic 1 Input Voltage vs. Temperature

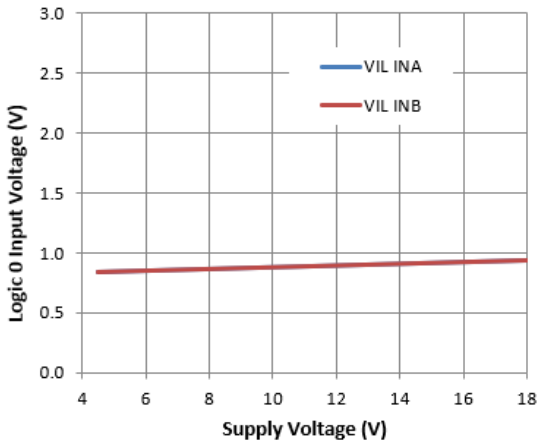

Figure 20. Logic 0 Input Voltage vs. Supply Voltage

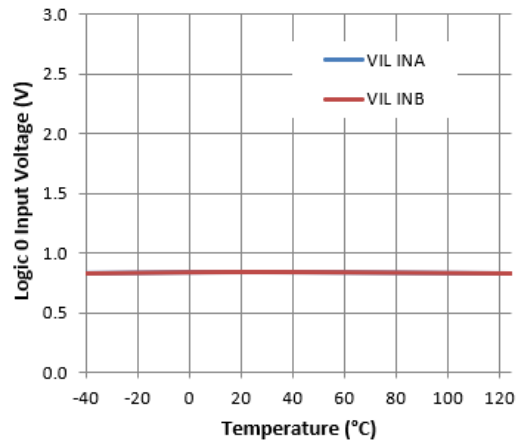
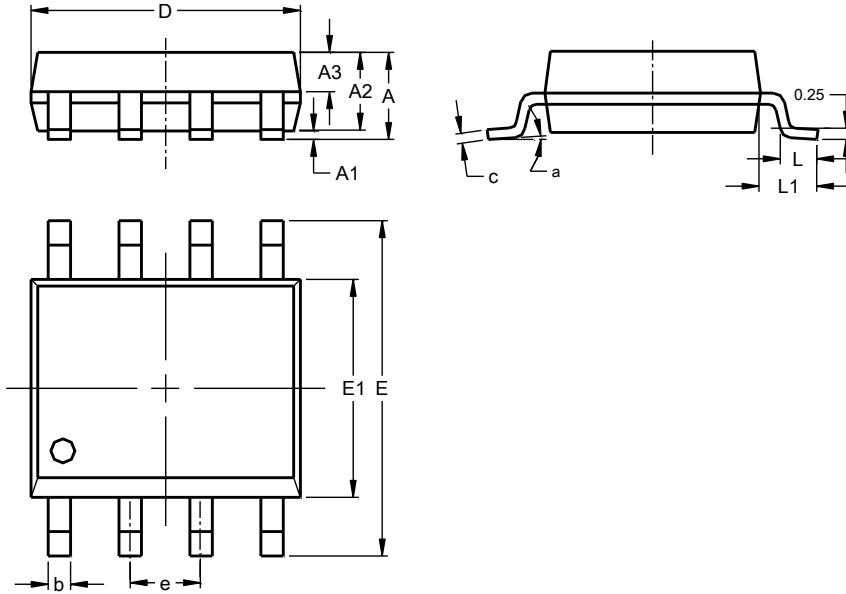

Figure 21. Logic 0 Input Voltage vs. Temperature

Package Outline Dimensions

Please see <http://www.diodes.com/package-outlines.html> for the latest version.

SO-8 (Type TH)



| SO-8 (Type TH) | | | |
|----------------------|---------|-------|------|
| Dim | Min | Max | Typ |
| A | -- | 1.75 | -- |
| A1 | 0.10 | 0.225 | -- |
| A2 | 1.30 | 1.50 | 1.40 |
| A3 | 0.60 | 0.70 | 0.65 |
| b | 0.39 | 0.47 | -- |
| c | 0.20 | 0.24 | -- |
| D | 4.80 | 5.00 | 4.90 |
| E | 5.80 | 6.20 | 6.00 |
| E1 | 3.80 | 4.00 | 3.90 |
| e | 1.27BSC | | |
| h | 0.25 | 0.50 | -- |
| L | 0.50 | 0.80 | -- |
| L1 | 1.05REF | | |
| a | 0° | 8° | -- |
| All Dimensions in mm | | | |

Suggested Pad Layout

Please see <http://www.diodes.com/package-outlines.html> for the latest version.

SO-8 (Type TH)

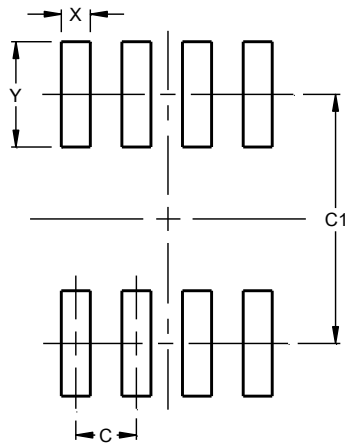

| Dimensions | Value (in mm) |
|------------|---------------|
| C | 1.27 |
| C1 | 5.20 |
| X | 0.60 |
| Y | 2.20 |

IMPORTANT NOTICE

1. DIODES INCORPORATED (Diodes) AND ITS SUBSIDIARIES MAKE NO WARRANTY OF ANY KIND, EXPRESS OR IMPLIED, WITH REGARDS TO ANY INFORMATION CONTAINED IN THIS DOCUMENT, INCLUDING, BUT NOT LIMITED TO, THE IMPLIED WARRANTIES OF MERCHANTABILITY, FITNESS FOR A PARTICULAR PURPOSE OR NON-INFRINGEMENT OF THIRD PARTY INTELLECTUAL PROPERTY RIGHTS (AND THEIR EQUIVALENTS UNDER THE LAWS OF ANY JURISDICTION).
2. The Information contained herein is for informational purpose only and is provided only to illustrate the operation of Diodes' products described herein and application examples. Diodes does not assume any liability arising out of the application or use of this document or any product described herein. This document is intended for skilled and technically trained engineering customers and users who design with Diodes' products. Diodes' products may be used to facilitate safety-related applications; however, in all instances customers and users are responsible for (a) selecting the appropriate Diodes products for their applications, (b) evaluating the suitability of Diodes' products for their intended applications, (c) ensuring their applications, which incorporate Diodes' products, comply the applicable legal and regulatory requirements as well as safety and functional-safety related standards, and (d) ensuring they design with appropriate safeguards (including testing, validation, quality control techniques, redundancy, malfunction prevention, and appropriate treatment for aging degradation) to minimize the risks associated with their applications.
3. Diodes assumes no liability for any application-related information, support, assistance or feedback that may be provided by Diodes from time to time. Any customer or user of this document or products described herein will assume all risks and liabilities associated with such use, and will hold Diodes and all companies whose products are represented herein or on Diodes' websites, harmless against all damages and liabilities.
4. Products described herein may be covered by one or more United States, international or foreign patents and pending patent applications. Product names and markings noted herein may also be covered by one or more United States, international or foreign trademarks and trademark applications. Diodes does not convey any license under any of its intellectual property rights or the rights of any third parties (including third parties whose products and services may be described in this document or on Diodes' website) under this document.
5. Diodes' products are provided subject to Diodes' Standard Terms and Conditions of Sale (<https://www.diodes.com/about/company/terms-and-conditions/terms-and-conditions-of-sales/>) or other applicable terms. This document does not alter or expand the applicable warranties provided by Diodes. Diodes does not warrant or accept any liability whatsoever in respect of any products purchased through unauthorized sales channel.
6. Diodes' products and technology may not be used for or incorporated into any products or systems whose manufacture, use or sale is prohibited under any applicable laws and regulations. Should customers or users use Diodes' products in contravention of any applicable laws or regulations, or for any unintended or unauthorized application, customers and users will (a) be solely responsible for any damages, losses or penalties arising in connection therewith or as a result thereof, and (b) indemnify and hold Diodes and its representatives and agents harmless against any and all claims, damages, expenses, and attorney fees arising out of, directly or indirectly, any claim relating to any noncompliance with the applicable laws and regulations, as well as any unintended or unauthorized application.
7. While efforts have been made to ensure the information contained in this document is accurate, complete and current, it may contain technical inaccuracies, omissions and typographical errors. Diodes does not warrant that information contained in this document is error-free and Diodes is under no obligation to update or otherwise correct this information. Notwithstanding the foregoing, Diodes reserves the right to make modifications, enhancements, improvements, corrections or other changes without further notice to this document and any product described herein. This document is written in English but may be translated into multiple languages for reference. Only the English version of this document is the final and determinative format released by Diodes.
8. Any unauthorized copying, modification, distribution, transmission, display or other use of this document (or any portion hereof) is prohibited. Diodes assumes no responsibility for any losses incurred by the customers or users or any third parties arising from any such unauthorized use.
9. This Notice may be periodically updated with the most recent version available at <https://www.diodes.com/about/company/terms-and-conditions/important-notice>

The Diodes logo is a registered trademark of Diodes Incorporated in the United States and other countries.
DIODES is a trademark of Diodes Incorporated in the United States and other countries.
All other trademarks are the property of their respective owners.
© 2023 Diodes Incorporated. All Rights Reserved.

www.diodes.com

Looking for pricing, stock, or lifecycle information?

Click below to explore more details on WIN SOURCE:

 [View DGD0227S8-13 on WIN SOURCE](#)

 [Diodes Incorporated](#) Information

Optimize Your Supply Chain with WIN SOURCE Solutions

-  Global Sourcing Solution
-  Obsolete Management
-  Cost Control Management
-  Shortage Management
-  Alternative Solution
-  Excess Inventory Management