



**THE DATASHEET OF
1212C2**



1200 series

Momentary pushbutton switches •
round plunger



DISTINCTIVE FEATURES

Butt action contacts

Double break

NF (EN 61058-1), UL and CSA approved



ELECTRICAL SPECIFICATIONS

- Max. current/voltage rating with resistive load :
 - silver contacts (A) : 4 A 250 VAC - 8 A 125 VAC - 4 A 24 VDC - 8 A 12 VDC
 - silver plated copper contacts (C) :
2 A 250 VAC - 3 A 125 VAC - 2 A 24 VDC - 3 A 12 VDC
- Initial contact resistance : 10 mΩ
- Insulation resistance : 1,000 MΩ min. at 500 VDC
- Dielectric strength :
 - 2,000 Vrms 50 Hz min. between terminals
 - 3,000 Vrms 50 Hz min. between terminals and frame
- Electrical life : 10,000 cycles at full load



GENERAL SPECIFICATIONS

- Torque : 1.50 Nm (1.10 Ft.lb) max. applied to nut
- Panel thickness : 5 mm (.196) max.
- Total travel :
 - NO : 4.5 mm (.177) ± 0.3 (.011)
 - NC : 3.5 mm (.137) ± 0.3 (.011)
- Operating temperature : -20 °C to +55 °C (-4 °F to +131 °F)



MATERIALS

- Case : polyamide
- Plunger : polyamide
- Bushing : brass, nickel plated
- Contacts :
 - A : silver
 - C : copper, silver plated

APEM products may be recycled at end-of-life for the re-claiming of valuable metal components.



1200 series

Momentary pushbutton switches • round plunger



MOUNTING

- Panel cut-out : Ø 12.2 (.480)

AGENCY APPROVALS



EN 61058-1 2 A 250 VAC or 4 A 250 VAC, T55/125 °C
All models



4 A 250 VAC - 8 A 125 VAC
All models function 3 (NO)

Models 1233X209 and 1233X209L are standard marked NF. To order switches marked NF, UL or CSA, complete appropriate box of ordering format.



TERMINALS

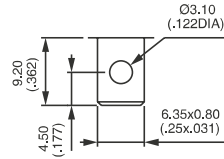

Solderlug / quick-connect.

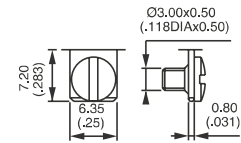

Screw

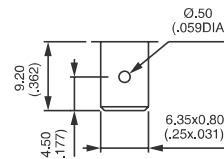

Normalized quick-connect

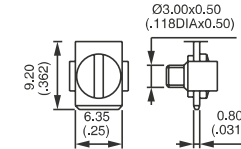

Screw + clamp



ELECTRICAL FUNCTIONS

→ KEYWAY

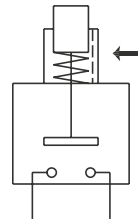

NO (function 3)

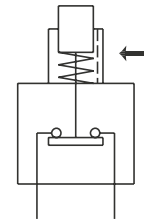

NC (function 2)

1200 series

Momentary pushbutton switches • round plunger



BUILD YOUR PART NUMBER

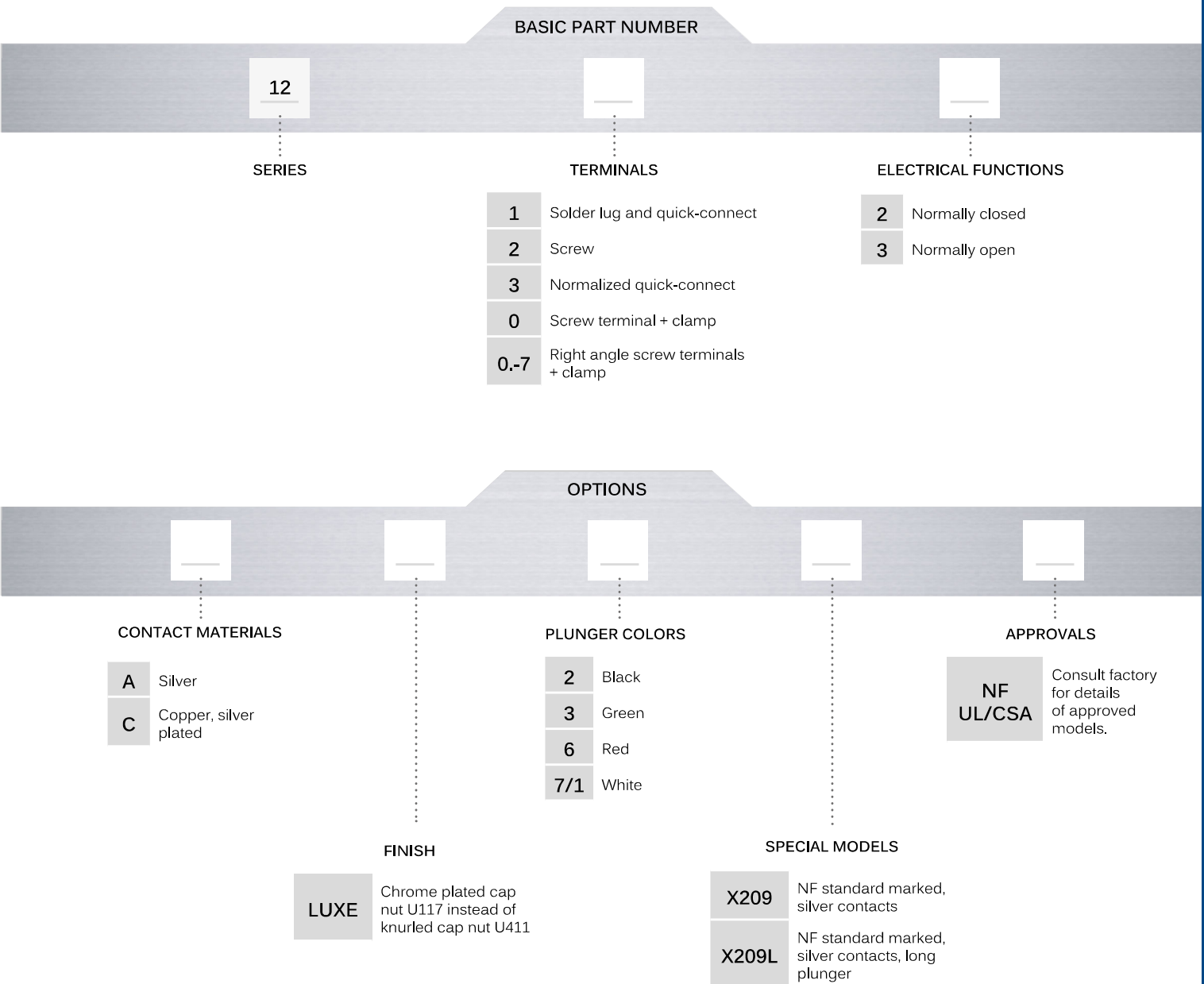

ABOUT THIS SERIES

On the following pages, you will find successively basic part numbers of switches and options in the same order as in above chart.

⚠ **Notice** : please note that not all combinations of above numbers are available. Refer to following pages for further information.

🔒 **Sealing boots** are available to protect the switches against dust and water. See "Sealing Boots" section of website.

🔧 **Mounting accessories** : standard hardware supplied :1 hex nut U166 and 1 knurled nut U411.
Standard and special hardware is presented in the "Hardware" section of website.

1200 series

Momentary pushbutton switches • round plunger

SOLDER LUG/QUICK-CONNECT TERMINALS



1212  Normally Closed

1213  Normally Open

Plunger height : NO model : 7.50 mm, NC model : 5.80 mm

SCREW TERMINALS



1222  Normally Closed

1223  Normally Open

Plunger height : NO model : 7.50 mm, NC model : 5.80 mm

NORMALIZED QUICK-CONNECT TERMINALS



1232  Normally Closed

1233  Normally Open

Plunger height : NO model : 7.50 mm, NC model : 5.80 mm

STRAIGHT SCREW TERMINALS + CLAMP



1202  Normally Closed

1203  Normally Open

KEYWAY

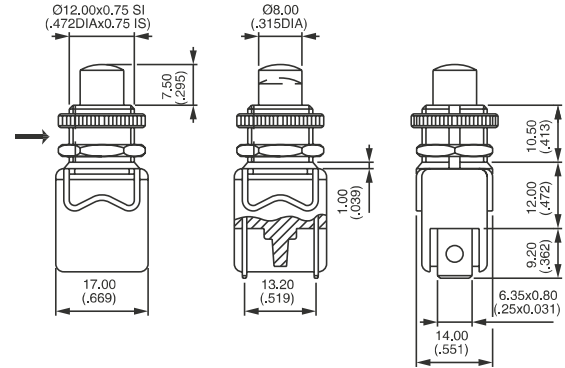

KEYWAY

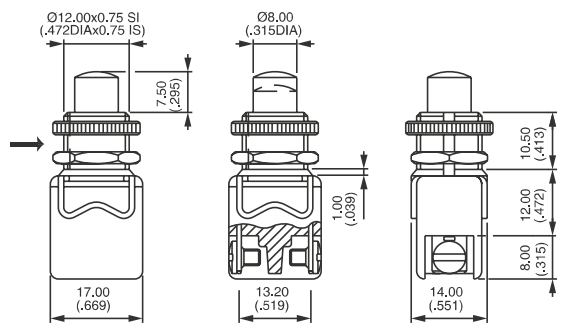

KEYWAY

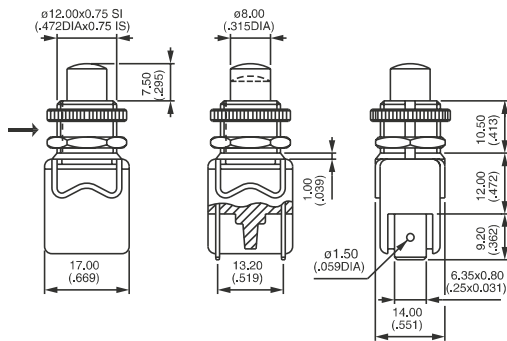

KEYWAY

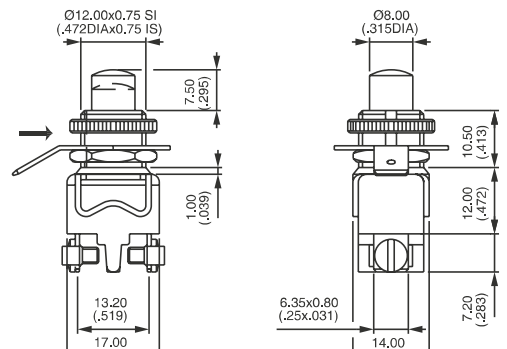

1200 series

Momentary pushbutton switches • round plunger

RIGHT ANGLE SCREW TERMINALS + CLAMP

1203-7  Normally Open

KEYWAY

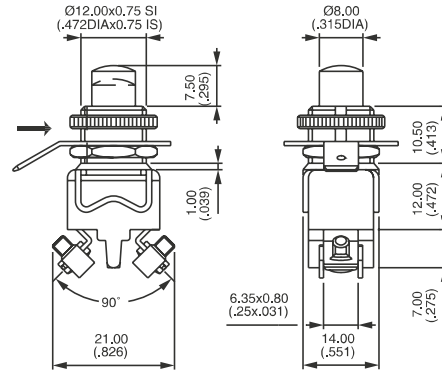

CONTACT MATERIALS

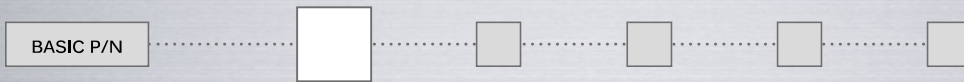

- A Silver
- C Copper, silver plated

FINISH



LUXE Chrome plated cap nut U117 instead of knurled nut U411

PLUNGER COLORS



- 2 Black
- 3 Green
- 6 Red
- 7/1 White

SPECIAL MODELS



X209 NF standard marked - Silver contacts - **short** plunger

X209L NF standard marked - Silver contacts - **long** plunger

See drawings next page.

NOTE : Ground connector U187 compulsory on models X209 and X209L if the panel is not metallic or not connected to ground. Order separately : see "Hardware" section of website.

1200 series

Momentary pushbutton switches • round plunger

SPECIAL MODELS (CONTINUED)

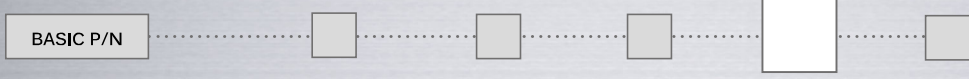

OPTION X209

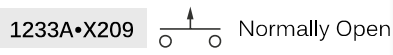

Replace • with the desired plunger color.

OPTION X209L

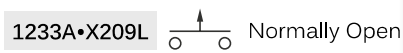

Replace • with the desired plunger color.

→ KEYWAY

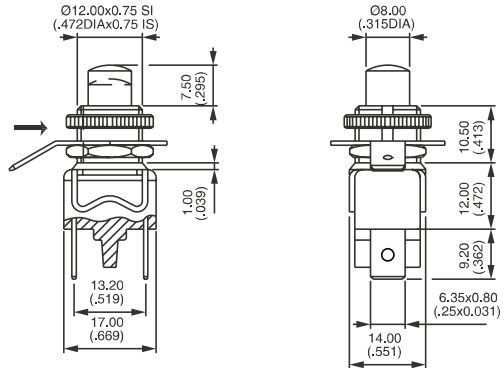

→ KEYWAY

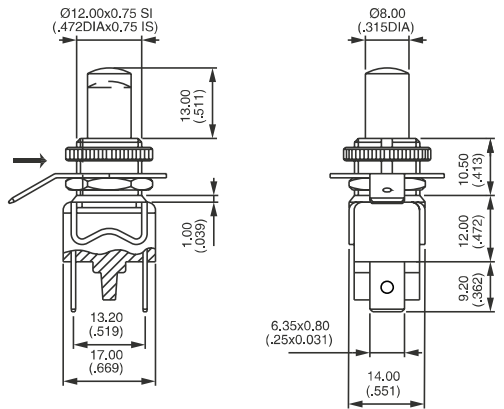

AGENCY APPROVALS

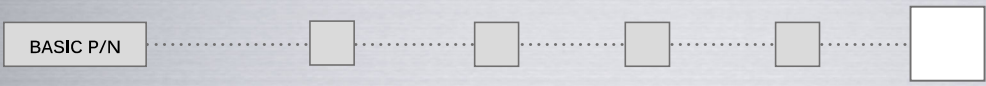

NF All models

UL-CSA All models function 3 (NO), including X209 and X209L

Marking : to order switches marked NF, UL or CSA, complete above box with desired approvals.

Looking for pricing, stock, or lifecycle information?

Click below to explore more details on WIN SOURCE:

 [View 1212C2 on WIN SOURCE](#)

 [Apem Inc. Information](#)

Optimize Your Supply Chain with WIN SOURCE Solutions

-  Global Sourcing Solution
-  Obsolete Management
-  Cost Control Management
-  Shortage Management
-  Alternative Solution
-  Excess Inventory Management