



**PI2DPX2063**

**1.8V 20Gbps DP2.0 Linear ReDriver with AUX Listener & I2C Control**

**Features**

- 4-to-4 Linear ReDriver™ Channel Configuration with CTLE Gain Compensation up to 16dB @20Gbps
- Supports 4-lane DP2.0 (UHBR20/UHBR13/UHBR10)/HDBR3/HBR2/RBR
- Ultra low Latency (< 300ps) for better Interoperability and Data throughput
- Individual Controls on CTLE Gain (6 to 16.2dB), Flat Gain (-4 to +2dB)
- Integrated AUX Channel Listener for D3 Power Saving Mode
- I2C Slave Support with Speed up to 1MHz
- Low Power - DisplayPort Active (<350mW), D3 Power Down Mode (1.8mW)
- Single Power Supply: 1.8V +/-5%
- Industrial Temperature Support: -40°C to +85°C
- Totally Lead-Free & Fully RoHS Compliant (Notes 1 & 2)
- Halogen and Antimony Free. “Green” Device (Note 3)
- For automotive applications requiring specific change control (i.e. parts qualified to AEC-Q100/101/104/200, PPAP capable, and manufactured in IATF 16949 certified facilities), please [contact us](#) or your local Diodes representative.   
<https://www.diodes.com/quality/product-definitions/>
- Packaging (Pb-free & Green):
  - Tiny 32-pin, WLGA, 2.85 x 4.5 mm (0.4 mm pitch) (FLA)

**Applications**

- Laptop, Desktop and AIO PCs
- Workstation and Server
- Docking Station
- Display Monitor
- Gaming Console
- Active Cable

**Description**

The DIODES™ PI2DPX2063 is a 20Gbps DP2.0/DP1.4 linear ReDriver in a 4-to-4 configuration operated by a 1.8v power supply. The device supports UHBR20 (DP2.0 20Gbps), UHBR13.5 (DP2.0 13.5Gbps), UHBR10 (DP2.0 10Gbps), HBR3 (DP1.4 8.1Gbps), HBR2 (DP1.2 5.4Gbps), HBR(DP1.1 2.7Gbps) and RBR(DP1.0 1.62Gbps) under various DisplayPort speeds. With the on-chip AUX channel listener, the device can automatically monitor the system operation status to enter D3 power saving mode.

The non-blocking linear ReDriver design ensures that the differential signals conveying pre-shoot and de-emphasis equalization waveforms from the transmitter side to the receiver side help optimize the overall channel link adjustment conducted by the system transmitter and receiver that has been equipped with DFE. The CTLE equalizers are implemented at the inputs of the ReDriver to compensate the channel loss and reduce the ISI jitters. The programmable flat gain adjustments support the eye diagram opening.

The CTLE EQ gains and flat gains are individually programmable on each channel for flexible tuning via I2C register settings.

**Ordering Information**

Ordering Number	Package Code	Description
PI2DPX2063FLAEX	FLA	32-Pin, W-LGA4528-32

Notes:

1. E = Pb-free and Green
2. X suffix = Tape/Reel

**Notes:**

1. No purposely added lead. Fully EU Directive 2002/95/EC (RoHS), 2011/65/EU (RoHS 2) & 2015/863/EU (RoHS 3) compliant.
2. See <https://www.diodes.com/quality/lead-free/> for more information about Diodes Incorporated’s definitions of Halogen- and Antimony-free, “Green” and Lead-free.
3. Halogen- and Antimony-free “Green” products are defined as those which contain <900ppm bromine, <900ppm chlorine (<1500ppm total Br + Cl) and <1000ppm antimony compounds.

DIODES is a trademark of Diodes Incorporated in the United States and other countries.

The Diodes logo is a registered trademark of Diodes Incorporated in the United States and other countries.

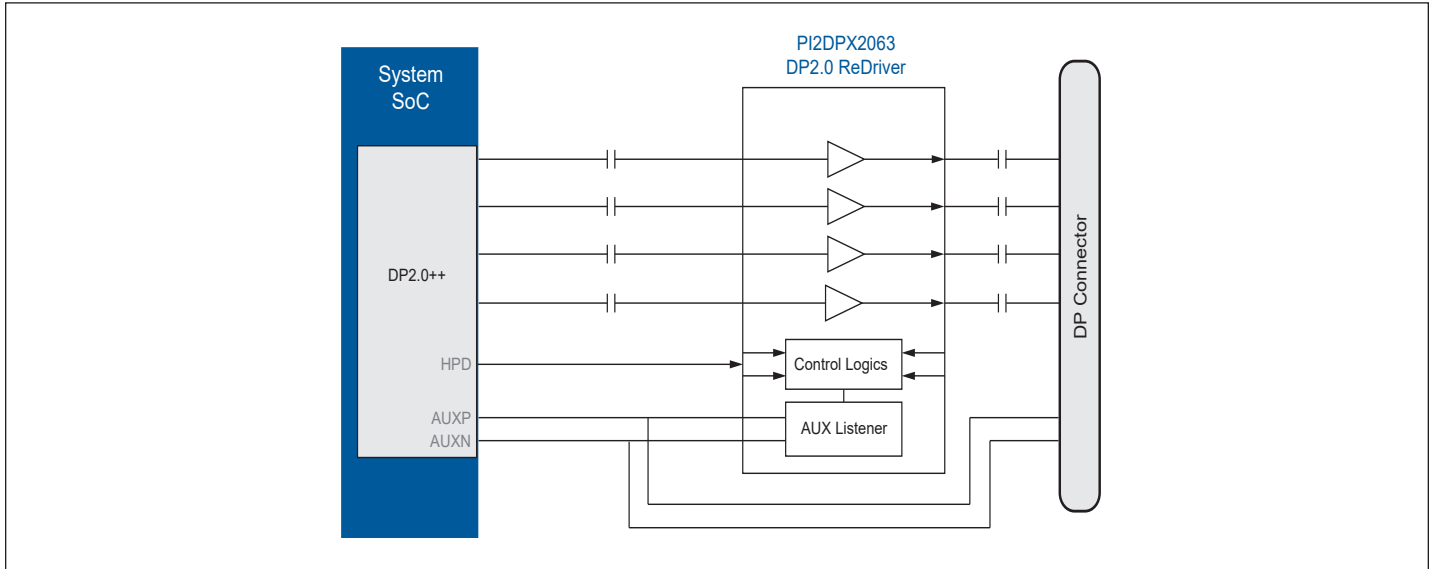
ReDriver is a trademark of Diodes Incorporated.

**PI2DPX2063**

## Revision History

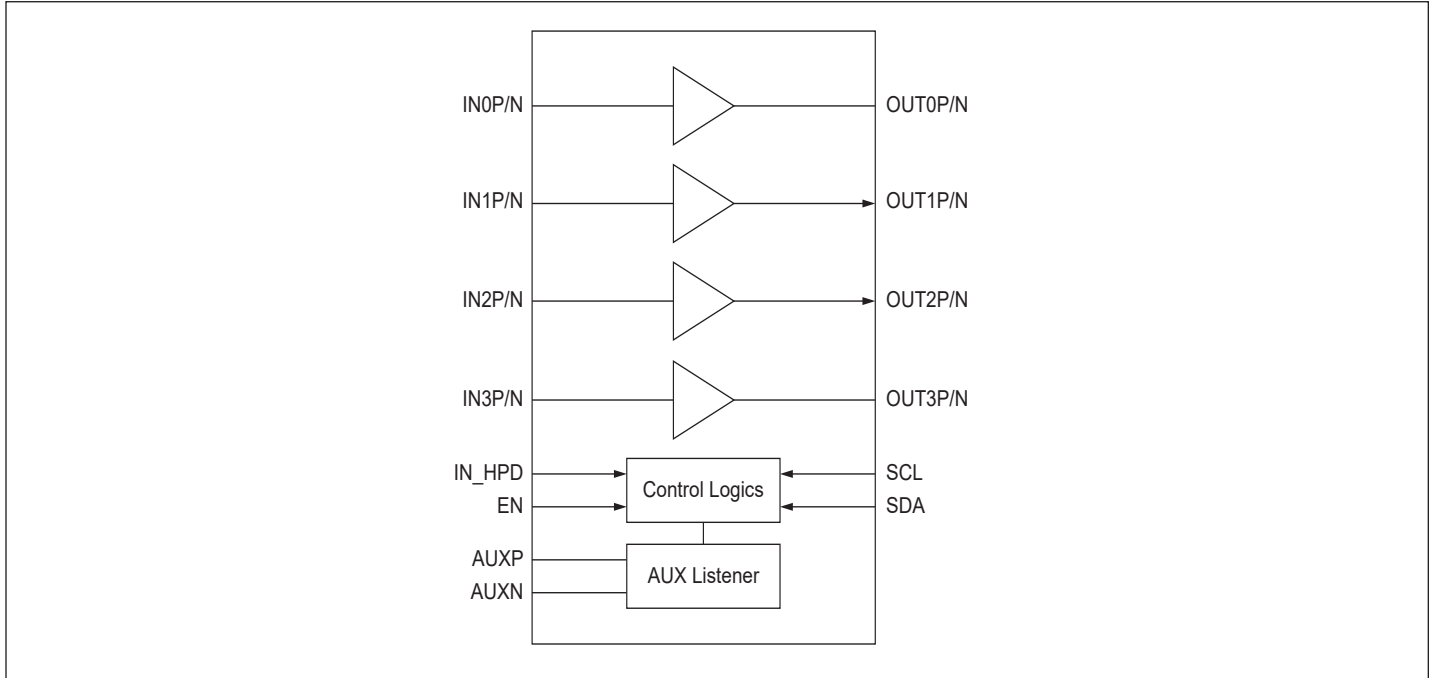
Date	Revision	Description
August 2021	1	Preliminary Datasheet Release
July 2022	2	Updated Absolute Maximum Ratings Updated CTLE Equalization Gain Updated Feature Updated Configuration Table Updated Diodes Format

**PI2DPX2063**

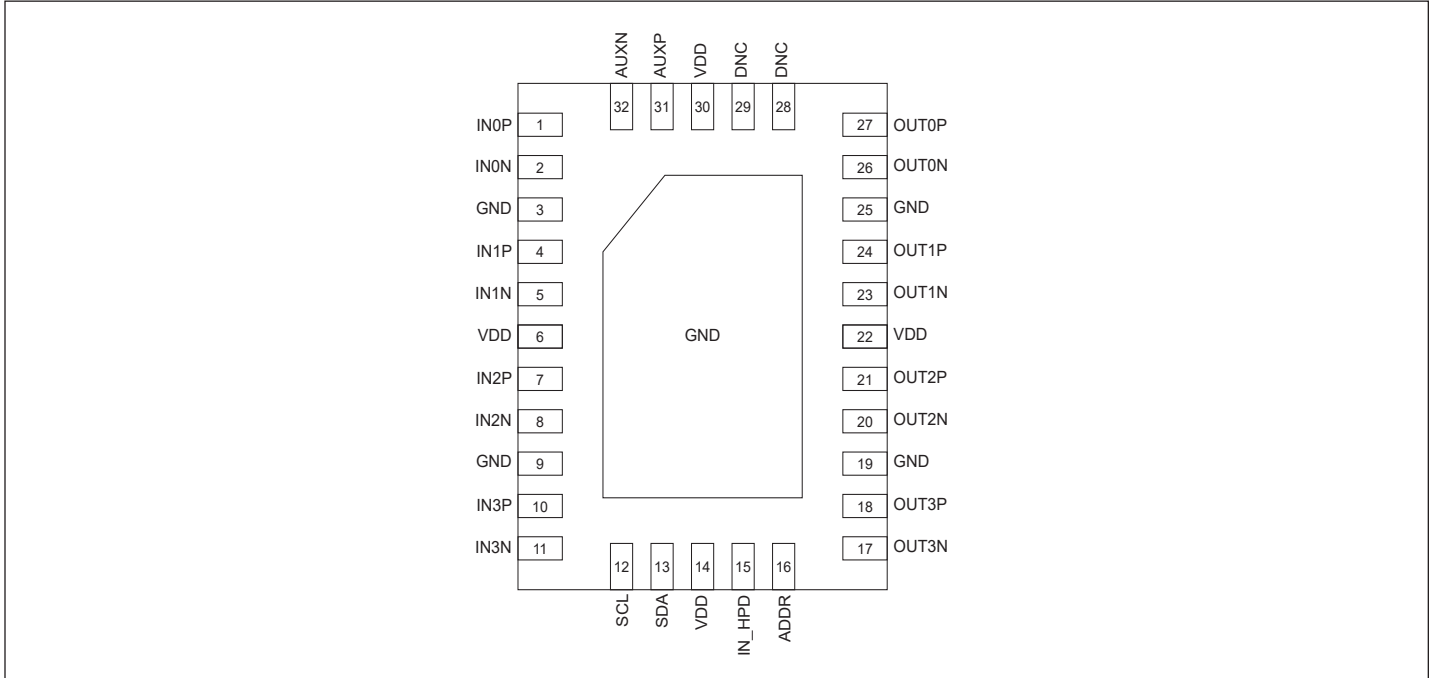


**PI2DPX2063 in DP2.0 PC Motherboard Application**

**Block Diagram**



**Pin Configuration (Top-Side View)**



**Pin Description**

Pin #	Pin Name	Type	Description
<b>Power and GND</b>			
6, 14, 22, 30	VDD	Power	1.8V power supply, ±5%
3, 9, 19, 25, Center Pad	GND	Ground	Supply ground
<b>Control Pins</b>			
12	SCL	I	SCL is I2C control bus clock. Open drain structure.
13	SDA	I/O	SDA is I2C control bus data. Open drain structure.
15	IN_HPD	I	Hot plug detection from Sink. With I2C (IN_HPD_HIZ) selectable internal 300kΩ pull-down resistor. IN_HPD_HIZ='0', 300kΩ pull-down. Otherwise, the pin is HiZ
16	ADDR	I	The I2C address select. 4-level input pin. With internal 100KΩ pull-up and 200KΩ pull-down resistors. External Pulldown resistor value is 68KΩ.
<b>High Speed I/O Pins</b>			
18, 17, 27, 26	OUT3P, OUT3N, OUT0P, OUT0N	O	Channel CML output terminals. With selectable output termination between 50Ω to VDD, 6kΩ to internal Vbi-asTx or Hi-Z

### Pin Description Cont.

Pin #	Pin Name	Type	Description
21, 20 24, 23	OUT2P, OUT2N OUT1P, OUT1N	O	Channel CML output terminals. With selectable output termination between 50Ω to VDD, 6KΩ to internal VbiasTx or Hi-Z
1, 2 10, 11	IN0P, IN0N IN3P, IN3N	I	Channel CML input terminals. With selectable input termination between 50Ω to internal VbiasRx, or 78KΩ to internal VbiasRx.
4, 5 7, 8	IN1P, IN1N IN2P, IN2N	I	Channel CML input terminals. With selectable input termination between 50Ω to internal VbiasRx, or 78KΩ to internal VbiasRx.
Side Band Signal Pins			
29, 28	DNC		Do Not connect
31, 32	AUXP, AUXN	I/O	DisplayPort AUX CH differential signal connections

## Operation Mode

Table 1. Configuration Table

OP_MODE<3:0>	IN0	IN1	IN2	IN3	AUXP	AUXN	Mode
0000-0001	-	-	-	-	-	-	Reserved
0010	OUT0 (DP0)	OUT1 (DP1)	OUT2 (DP2)	OUT3 (DP3)	-	-	4-lane DP + AUX
0011	OUT0 (DP3)	OUT1 (DP2)	OUT2 (DP1)	OUT3 (DP0)	-	-	4-lane DP + AUX (flipped)
<0100> ~ <1111>	-	-	-	-	-	-	Reserved

Notes: 1) <0010> default at power on.

## I/O Termination Resistance under Different Conditions

Symbol	Parameter	Resistance	Units
<b>RX Terminal</b>			
R <sub>in-pd</sub>	Input res at EN=0	78k to GND	Ω
R <sub>in-Active</sub>	Input res at active mode condition	50 to V <sub>biasRx1</sub>	Ω
R <sub>in-DP-standby</sub>	Input res in DP standby mode	78k to GND	Ω
R <sub>in-DP-active</sub>	Input res in DP active mode	50 to V <sub>biasRx1</sub>	Ω
R <sub>in-DP-D3</sub>	Input res in DP D3 mode	78k to GND	Ω
<b>TX Terminal</b>			
R <sub>out-pd</sub>	Output res at EN=0	78k to GND	Ω
R <sub>out-Active</sub>	Output res at active mode condition	50 to VDD	Ω
R <sub>out-DP-standby</sub>	Output res in DP standby mode	78k to GND	Ω
R <sub>out-DP-active</sub>	Output res in DP active mode	50 to VDD	Ω
R <sub>out-DP-D3</sub>	Output res in DP D3 mode	78k to GND	Ω

## DisplayPort Mode

By default, all channels will go to active mode if HPD bit = 1. The ON/OFF of each DP channel is controlled by the Aux lane count.

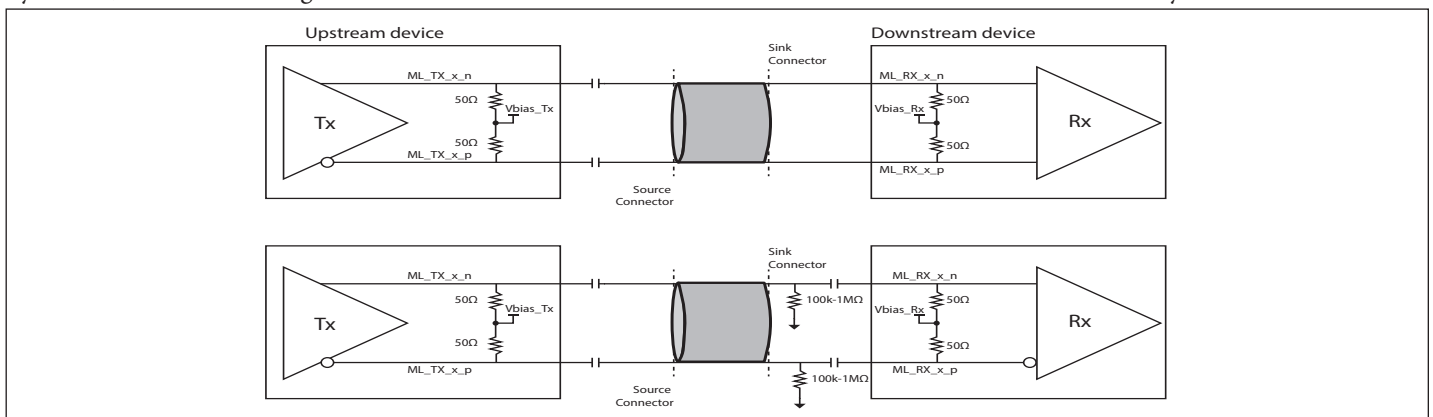
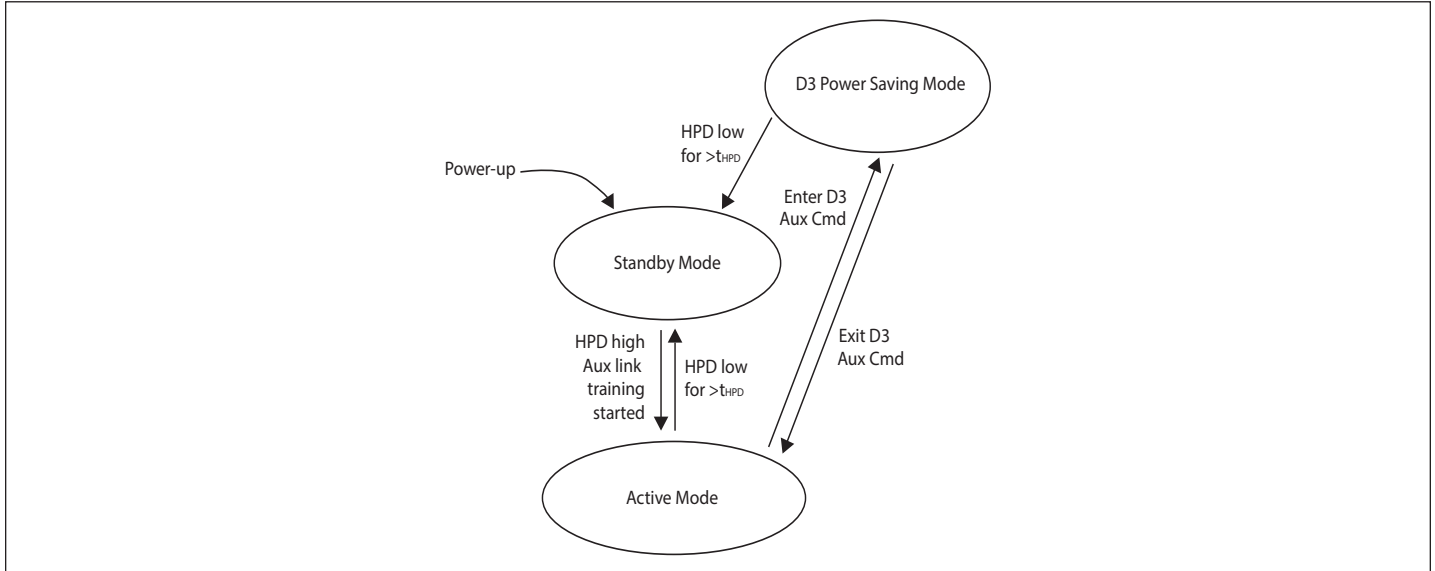


Figure 1. DisplayPort Main Link Connection Diagram

**DisplayPort Main Link**

The electrical sub-block of a DP Main-Link consists of up to four differential pairs. The DP TX drives doubly terminated, AC-coupled differential pairs in a manner compliant with the Main-Link Transmitter electrical specification.



**Figure 2. DisplayPort Operation Modes**

**Table 2. Description of DP Operating Mode**

PM_State	Mode	Description
1	Standby Mode	Low power consumption (AUX listener is OFF); Main Link outputs are disabled
2	Active Mode	Data transfer (normal operation); AUX listener is active. The AUX listener is actively monitoring for Link Training unless it is disabled through I2C interface. After power-up and in active mode, all Main Link outputs are enabled. AUX Link Training is necessary to overwrite the DPCD registers to enable/disable Main Link outputs.
3	D3 Power Saving Mode	Low power consumption(AUX listener is active); Main Link outputs are disabled

## CTLE Equalization, Flat Gain and Chip Enable Controls

Table 3. CTLE Equalization Gain (Typical Values at FG = 0dB)

I2C Register Setting EQ<2:0>			Equalizer Setting (dB)				
EQ<2>	EQ<1>	EQ<0>	@1.35GHz	@2.5GHz	@4GHz	@5GHz	@10GHz
0	0	0	-0.1 (Default)	0.1 (Default)	0.7 (Default)	1.3 (Default)	6.0 (Default)
0	0	1	0.0	0.6	1.6	2.5	8.5
0	1	0	0.2	1.3	2.8	4.1	10.8
0	1	1	0.6	2.2	4.3	5.8	12.7
1	0	0	1.1	3.5	6.0	7.7	14.2
1	0	1	1.7	4.8	7.6	9.3	15.2
1	1	0	2.6	6.3	9.2	10.8	15.8
1	1	1	3.5	7.5	10.4	11.8	16.2

Note: F: Floating, R: External resistor to ground.

Table 4. Flat Gain Setting (FG)

I2C Register FG[1:0]		Flat Gain Setting
0	0	-4 dB
0	1	-2 dB
1	0	+0 dB (Default)
1	1	+2 dB

## Maximum Ratings

(Above which useful life may be impaired. For user guidelines, not tested.)

Storage Temperature . . . . .	-65°C to +150°C
Junction Temperature . . . . .	+125°C
Supply Voltage to Ground Potential . . . . .	-0.5V to VDD+0.3V
Voltage Input to High Speed Differential Pins . . . . .	-0.5V to VDD
Voltage Input to Low Speed Pins (SCL, SDA) . . . . .	-0.5V to +3.3V
Voltage Input to Low Speed Pins (AUXP/N). . . . .	-0.5V to +3.3V
ESD, HBM. . . . .	±4000V
ESD, CDM. . . . .	±1000V

Note:

Stresses greater than those listed under MAXIMUM RATINGS may cause permanent damage to the device. This is a stress rating only and functional operation of the device at these or any other conditions above those indicated in the operational sections of this specification is not implied. Exposure to absolute maximum rating conditions for extended periods may affect reliability.

## Thermal Information

Symbol	Parameter	32-Pin X2QFN Package	Units
Theta JA	Junction to Ambient Thermal Resistance	49.7	°C/W

## Recommended Operating Conditions

Symbol	Parameter	Min.	Typ.	Max.	Units
V <sub>DD</sub>	Supply Voltage	1.71	1.8	1.89	V
V <sub>DD_Noise</sub>	Power Supply Noise Up to 50MHz			50	mVpp
V <sub>RX_CM</sub>	Input Source Common-Mode Noise			150	mVpp
C <sub>ac_coupling</sub>	System AC Coupling Capacitance	75		265	nF
T <sub>A</sub>	Ambient Temperature	-40 <sup>(1)</sup>		+85	°C

Note:

1. The minimum temperature -40°C guaranteed by design

## Power Consumption

Symbol	Parameter	Min.	Typ.	Max.	Units
I <sub>ON_4DP</sub>	4-lane DP2.0		160	220	mA
I <sub>D3</sub>	Display Port D3 power down mode		1	1.6	mA
I <sub>ENB</sub>	Disabled mode ( EN= Low)		8	30	uA

## AC/DC Characteristics

**(V<sub>DD</sub> = 1.8 ± 5%, T<sub>A</sub> = -40°C to 85°C)**

Symbol	Parameter	Conditions	Min.	Typ.	Max.	Units
V <sub>DD</sub>	Supply Voltage	—	1.71	1.8	1.89	V

## Receiver (RX) (100 Ω differential) Electrical Specification

R <sub>RX-DIFF-DC</sub>	DC Differential Input Impedance		72		120	Ω
-------------------------	---------------------------------	--	----	--	-----	---

Symbol	Parameter	Conditions	Min.	Typ.	Max.	Units
R <sub>RX-SINGLE-DC</sub>	DC single ended input impedance to guarantee RxDet	Measured with respect to GND over a voltage of 500mV max	18		30	Ω
Z <sub>RX-HIZ-DC-PD</sub>	DC input CM input impedance for V>0 during reset or power down	(V <sub>cm</sub> =0 to 500mV)	25			kΩ
C <sub>ac_coupling</sub>	AC coupling capacitance		75		265	nF
V <sub>RX-CM-AC-P</sub>	Rx common mode peak voltage	AC up to 5GHz			150	mV <sub>peak</sub>
V <sub>RX-CM-DC-Active-Idle-Delta-P</sub>	Common mode peak voltage  AvgU0 (  V <sub>TX-D+</sub> + V <sub>TX-D-</sub>  )/2 - AvgU1 (  V <sub>TX-D+</sub> + V <sub>TX-D-</sub>  )/2				200	mV <sub>peak</sub>
<b>Transmitter (TX) Electrical Specification</b>						
V <sub>TX-DIFF-PP</sub>	Output differential p-p voltage Swing	Differential Swing  V <sub>TX-D+</sub> - V <sub>TX-D-</sub>		1		V <sub>ppd</sub>
R <sub>TX-DIFF-DC</sub>	DC Differential TX Impedance		72		120	Ω
V <sub>TX-RCV-DET</sub>	The amount of Voltage change allowed during RxDet	Type-C Tx Spec +/-60mA			600	mV
C <sub>ac_coupling</sub>	AC coupling capacitance		75		265	nF
R <sub>TX-DC-CM</sub>	Common mode DC output Impedance		18		30	Ω
I <sub>TX-SHORT</sub>	Transmitter short circuit current limit				60	mA
V <sub>TX-C</sub>	Common-Mode Voltage	V <sub>TX-D+</sub> + V <sub>TX-D-</sub>   /2	VDD-1V		VDD	V
V <sub>TX-DC-CM</sub>	Instantaneous allowed DC common mode voltage at the connector side of the AC coupling capacitors	V <sub>TX-D+</sub> + V <sub>TX-D-</sub>   /2	0		VDD	V
V <sub>TX-CM-AC-PP-Active</sub>	Active mode TX AC common mode voltage	V <sub>TX-D+</sub> + V <sub>TX-D-</sub> for both time and amplitude			100	mV <sub>pp</sub>
V <sub>TX-Idle-Diff-AC-pp</sub>	Idle mode AC common mode delta voltage   V <sub>TX-D+</sub> - V <sub>TX-D-</sub>	Between D+ and D- in idle mode. Use the HPF to remove DC components. =1/LPF.			10	mV <sub>ppd</sub>
V <sub>TX-Idle-Diff-DC</sub>	Idle mode DC common mode delta voltage   V <sub>TX-D+</sub> - V <sub>TX-D-</sub>	Between D+ and D- in idle mode. Use the LPF to remove AC components. =1/HPF.			10	mV
<b>Channel Performance</b>						
T <sub>pd</sub>	Latency	From input to output		25	150	ps

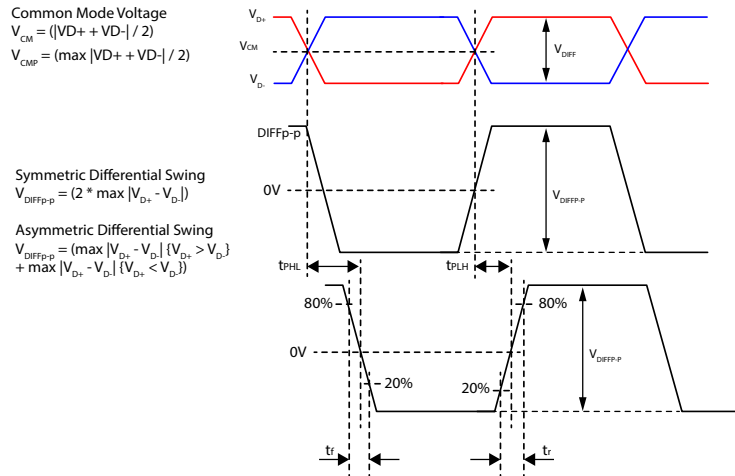
**AC/DC Characteristics Cont.**

Symbol	Parameter	Conditions	Min.	Typ.	Max.	Units
G <sub>P_USB</sub>	Peaking gain (Compensation at 10GHz, relative to 100MHz, 100mV <sub>p-p</sub> sine wave input)	EQ<2:0> = 000		6		dB
		EQ<2:0> = 001		8.5		
		EQ<2:0> = 010		10.8		
		EQ<2:0> = 011		12.7		
		EQ<2:0> = 100		14.2		
		EQ<2:0> = 101		15.2		
		EQ<2:0> = 110		15.8		
		EQ<2:0> = 111		16.2		
	Variation around typical		-2		+2	dB
G <sub>F</sub>	Flat gain (100MHz, EQ<2:0>=000)	FG<1:0> = 00		-4		dB
		FG<1:0> = 01		-2		
		FG<1:0> = 10		0		
		FG<1:0> = 11		+2		
			Variation around typical		-2	
V <sub>sw_100M</sub>	Output linear swing (at 100MHz)	EQ<2:0>=000		910		mVppd
V <sub>sw_10G</sub>	Output linear swing (at 10GHz)	EQ<2:0>=000		800		mVppd
DDNEXT	Differential near-end crosstalk	100MHz to 10GHz, Fig. 6		-30		dB
DDFEXT <sup>(2)</sup>	Differential far-end crosstalk	100MHz to 10GHz, Fig. 7		-30		dB
V <sub>NOISE_IN</sub>	Input-referred noise	100MHz to 10GHz, EQ<2:0>=000, FG<1:0>=10, Fig. 8		0.6		mV <sub>RMS</sub>
		100MHz to 10GHz, EQ<2:0>=111, FG<1:0>=10, Fig. 8		0.3		
V <sub>NOISE_OUT</sub>	Output-referred noise	100MHz to 10GHz, EQ<2:0>=000, FG<1:0>=10, Fig. 8		0.3		mV <sub>RMS</sub>
		100MHz to 10GHz, EQ<2:0>=111, FG<1:0>=10, Fig. 8		0.5		
S11DM	Input differential mode return loss	10MHz to 10GHz differential mode		-11.5	-8.1	dB
S11CM	Input common mode return loss	1GHz to 10GHz common mode		-10	-5	dB
S22DM	Output differential mode return loss	10MHz to 10GHz differential mode		-12.5	-8.1	dB
S22CM	Output common mode return loss	1GHz to 10GHz common mode		-8	-4	dB

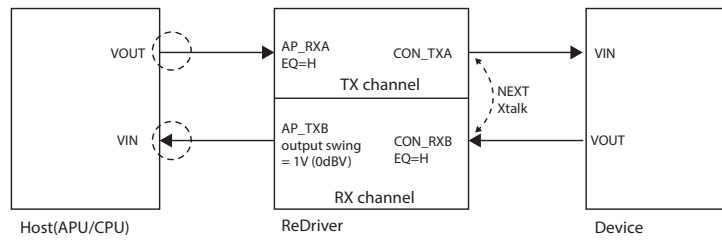
**AC/DC Characteristics Cont.**

Symbol	Parameter	Conditions	Min.	Typ.	Max.	Units
<b>DisplayPort Electrical Specification</b>						
V <sub>TX-C</sub>	Common-Mode Voltage	$ V_{TX-D+} + V_{TX-D-}  / 2$	VDD-1V		VDD	V
V <sub>TX-AC-CM_HBR_RBR</sub>	TX AC common mode voltage for HBR and RBR	Measured using an 8b/10b pattern with 50% transition density			20	mVrms
V <sub>TX-AC-CM_HBR2</sub>	TX AC common mode voltage for HBR2				30	mVrms
V <sub>TX-DIFFp-p-Level0</sub>	Differential peak-to-peak output voltage swing Level 0	Tested with Pre-emphasis at Level 0= 0dB Level 1= 3.5dB Level 2= 6.0 dB	0.34	0.4	0.46	V
V <sub>TX-DIFFp-p-Level1</sub>	Differential peak-to-peak output voltage swing Level 1		0.51	0.6	0.68	V
V <sub>TX-DIFFp-p-Level2</sub>	Differential peak-to-peak output voltage swing Level 2		0.69	0.8	0.92	V
T <sub>j</sub> TX Total Jitter	UHBR20(20Gbps) TP2	Measured at Transmit output. Prechannel loss from 2.5dB to 13dB			0.45	UI
	UHBR13(13.5Gbps) TP2				0.45	UI
	UHBR10(10Gbps) TP2				0.38	UI
	HBR3 (8.1Gbps)				0.27	UI
	HBR2 (5.4Gbps)				0.27	UI
	HBR (2.7Gbps)				0.294	UI
	RBR (1.62Gbps)				0.18	UI
<b>AUX Listener Electrical Specification</b>						
C <sub>in</sub>	Input capacitance at AUXP or AUXN				10	pF
V <sub>T(AUX_listener)</sub>	Threshold of the AUX listener	VCC = 1.8V	100		220	mVPPd

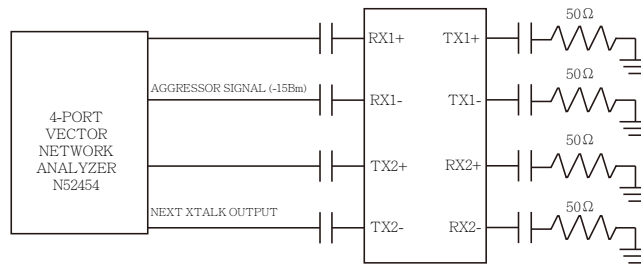
- Note:
1. Measured using a vector-network analyzer (VNA) with -30dBm power level applied to the adjacent input. The VNA detects the signal at the output of the victim channel. All other inputs and outputs are terminated with 50Ω.
  2. Subtract the channel gain from the total gain to derive the actual crosstalk



**Figure 4. Definition of Peak-to-peak Differential Voltage**

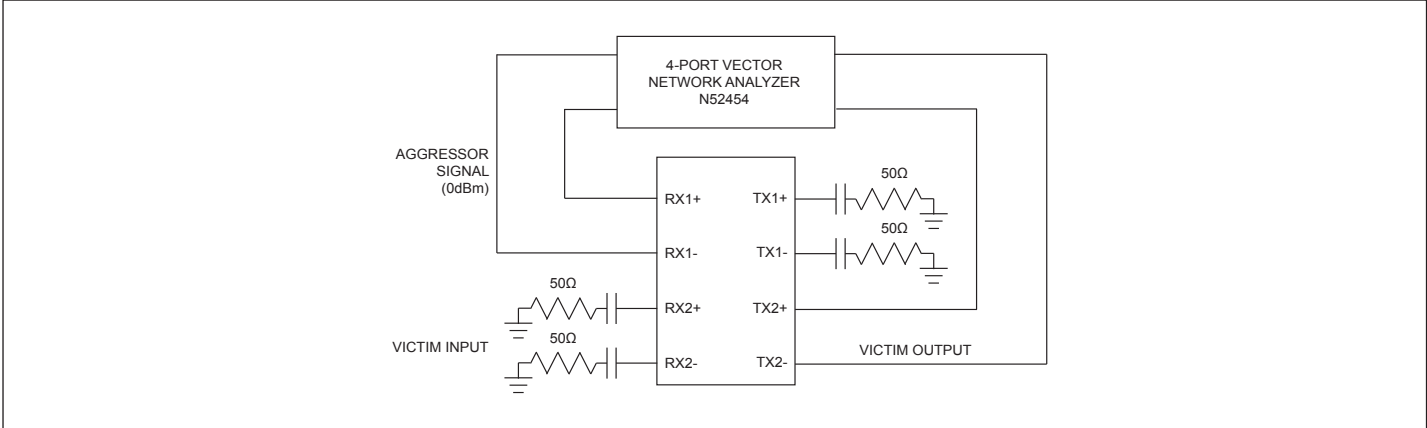


**Figure 5. NEXT Crosstalk Definition**

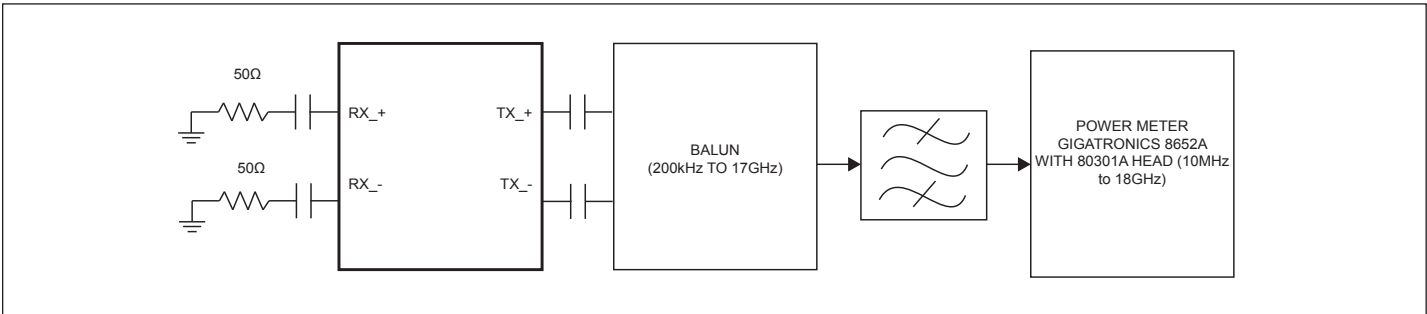


**Figure 6. NEXT Channel-isolation Test Configuration**

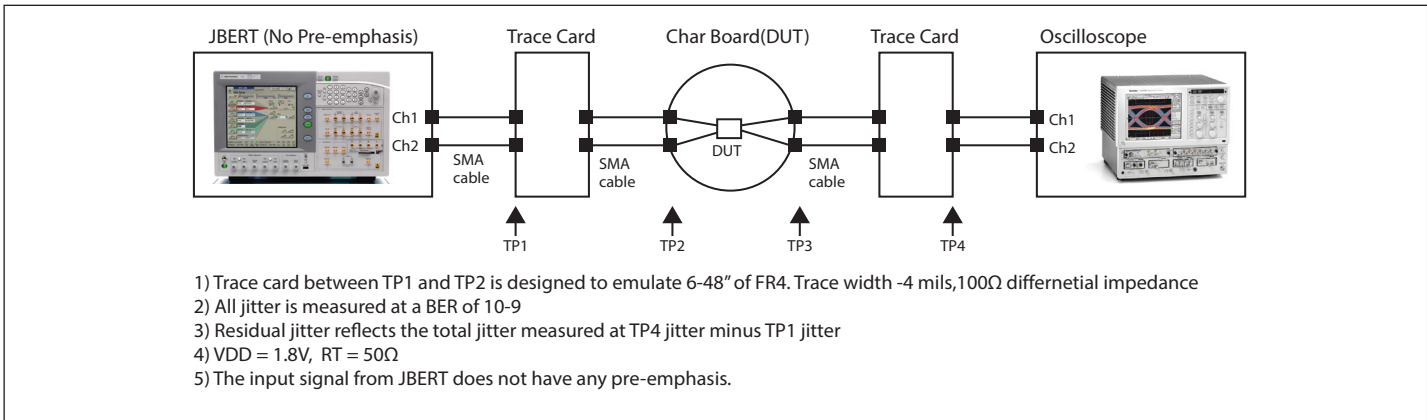
**PI2DPX2063**



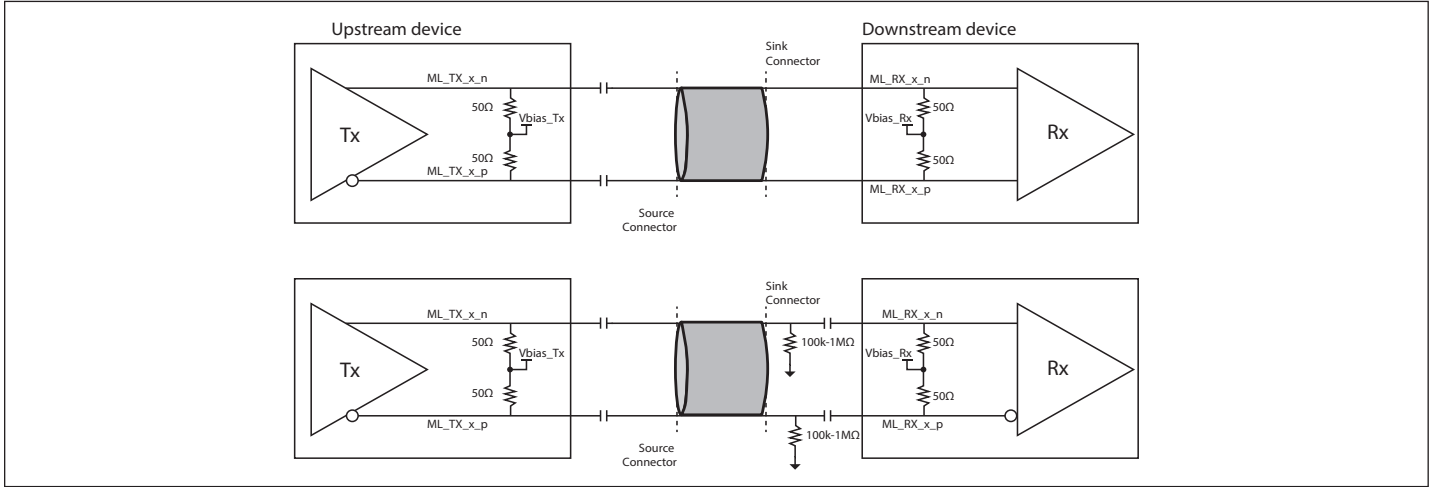
**Figure 7. NEXT Channel-isolation Test Configuration**



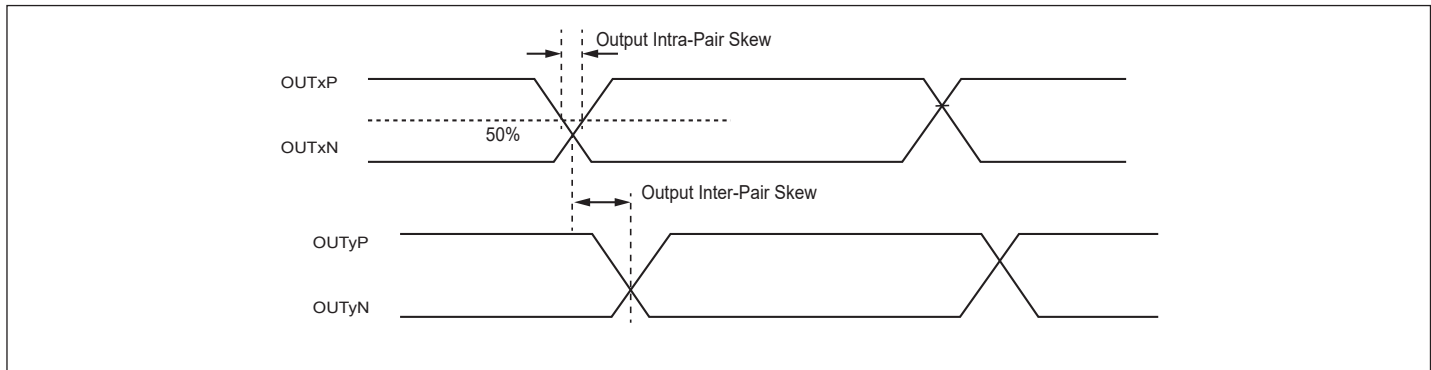
**Figure 8. Noise Test Configuration**



**Figure 9. Channel Measurement Setup**



**Figure 10. High-speed Channel Test Circuit**



**Figure 11. Intra and Inter-pair Differential Skew Definition**

## I2C Electrical Specification and Timing

### Characteristics of the SDA and SCL I/O Stages

Symbol	Parameter	Conditions	This Silicon		Fast-Mode Plus		Units
			Min.	Max.	Min.	Max.	
V <sub>IL</sub>	LOW-level input voltage		-0.5	0.3V <sub>DD</sub>	-0.5	0.3V <sub>DD</sub>	V
V <sub>IH</sub>	HIGH-level input voltage		0.7V <sub>DD</sub>		0.7V <sub>DD</sub>		V
V <sub>hys</sub>	Hysteresis of Schmitt trigger inputs		0.05V <sub>DD</sub>		0.05V <sub>DD</sub>		V
V <sub>OL1</sub>	LOW-level output voltage 1	Open-drain or open-collector at 3mA sink current; V <sub>DD</sub> > 2V	0	0.4	0	0.4	V
I <sub>OL</sub>	LOW-level output current	V <sub>OL</sub> = 0.4V	20		20		mA
t <sub>of</sub>	output fall time from V <sub>IHmin</sub> to V <sub>ILmax</sub>		12	120	20×(V <sub>DD</sub> /5.5V)	120	ns
t <sub>SP</sub>	Pulse width of spikes that must be suppressed by the input filter		0	50	0	50	ns
I <sub>i</sub>	Input current each I/O pin	0.1V <sub>DD</sub> < V <sub>I</sub> < 0.9V <sub>DDmax</sub>	-10	+10	-10	+10	uA
C <sub>i</sub>	Capacitance for each I/O pin			10		10	pF

### Characteristics of the SDA and SCL Bus Lines the Devices

Symbol	Parameter	Conditions	This Silicon		Fast-Mode Plus		Units
			Min.	Max.	Min.	Max.	
f <sub>SCL</sub>	SCL clock frequency		10	1000	0	1000	kHz
t <sub>HD;STA</sub>	Hold time (repeated) START condition	After this period, the first clock pulse is generated.	0.26		0.26		us
t <sub>LOW</sub>	LOW period of the SCL clock		0.5		0.5		us
t <sub>HIGH</sub>	HIGH period of the SCL clock		0.26		0.26		us
t <sub>SU;STA</sub>	Set-up time for a repeated START condition		0.26		0.26		us
t <sub>SU;DAT</sub>	Data set-up time		50		50		ns
t <sub>r</sub>	Rise time of both SDA and SCL signals			120		120	ns
t <sub>f</sub>	Fall time of both SDA and SCL signals		12	120	20×(V <sub>DD</sub> /5.5V)	120	ns
t <sub>SU;STO</sub>	Set-up time for STOP condition		0.26		0.26		us
t <sub>BUF</sub>	Bus free time between a STOP and START condition		0.5		0.5		us

**Characteristics of the SDA and SCL Bus Lines the Devices Cont.**

Symbol	Parameter	Conditions	This Silicon		Fast-Mode Plus		Units
			Min.	Max.	Min.	Max.	
$C_b$	Capacitive load for each bus line			550		550	pF
$t_{VD;DAT}$	Data valid time			0.45		0.45	us
$t_{VD;ACK}$	Data valid acknowledge time			0.45		0.45	us
$V_{nL}$	Noise margin at the LOW level	For each connected device (including hysteresis)	$0.1V_{DD}$		$0.1V_{DD}$		V
$V_{nH}$	Noise margin at the HIGH level	For each connected device (including hysteresis)	$0.2V_{DD}$		$0.2V_{DD}$		V

**Reference Electrical Specification and Timing (Extracted from I2C specification Rev2.6)**
**Characteristics of the SDA and SCL I/O Stages**

Symbol	Parameter	Conditions	Standard-Mode		Fast-Mode		Fast-Mode Plus		Units
			Min.	Max.	Min.	Max.	Min.	Max.	
$V_{IL}$	LOW-level input voltage <sup>(1)</sup>		-0.5	$0.3V_{DD}$	-0.5	$0.3V_{DD}$	-0.5	$0.3V_{DD}$	V
$V_{IH}$	HIGH-level input voltage <sup>(1)</sup>		$0.7V_{DD}$	<sup>(2)</sup>	$0.7V_{DD}$	<sup>(2)</sup>	$0.7V_{DD}$ <sup>(1)</sup>	<sup>(2)</sup>	V
$V_{hys}$	Hysteresis of Schmitt trigger inputs				$0.05V_{DD}$		$0.05V_{DD}$		V
$V_{OL1}$	LOW-level output voltage 1	Open-drain or open-collector at 3mA sink current; $V_{DD} > 2V$	0	0.4	0	0.4	0	0.4	V
$V_{OL2}$	LOW-level output voltage 2	Open-drain or open-collector at 2mA sink current <sup>(3)</sup> ; $V_{DD} \leq 2V$			0	$0.2V_{DD}$	0	$0.2V_{DD}$	V
$I_{OL}$	LOW-level output current	$V_{OL} = 0.4V$	3		3		20		mA
		$V_{OL} = 0.6V$ <sup>(4)</sup>			6				
$t_{of}$	Output fall time from $V_{IHmin}$ to $V_{ILmax}$			$250$ <sup>(5)</sup>	$20 \times (V_{DD} / 5.5V)$ <sup>(6)</sup>	$250$ <sup>(5)</sup>	$20 \times (V_{DD} / 5.5V)$ <sup>(6)</sup>	$120$ <sup>(7)</sup>	ns
$t_{SP}$	Pulse width of spikes that must be suppressed by the input filter				0	$50$ <sup>(8)</sup>	0	$50$ <sup>(8)</sup>	ns
$I_i$	Input current each I/O pin	$0.1V_{DD} < V_I < 0.9V_{D-Dmax}$	-10	+10	$-10$ <sup>(9)</sup>	$+10$ <sup>(9)</sup>	$-10$ <sup>(9)</sup>	$+10$ <sup>(9)</sup>	$\mu A$
$C_i$	Capacitance for each I/O pin <sup>(10)</sup>			10		10		10	pF

- Note:
- Some legacy Standard-mode devices had fixed input levels of  $V_{IL} = 1.5V$  and  $V_{IH} = 3.0V$ . Refer to component datasheet.
  - Maximum  $V_{IH} = V_{DD(max)} + 0.5V$  or  $5.5V$ , which ever is lower. See component datasheet.
  - The same resistor value to drive 3mA at  $3.0V V_{DD}$  provides the same RC time constant when using  $<2V V_{DD}$  with a smaller current draw.
  - In order to drive full bus load at 400kHz, 6mA  $I_{OL}$  is required at 0.6V  $V_{OL}$ . Parts not meeting this specification can still function, but not at 400kHz and 400pF.
  - The maximum  $t_f$  for the SDA and SCL bus lines quoted in Table 10 (300ns) is longer than the specified maximum  $t_{of}$  for the output stages (250ns). This allows series protection resistors ( $R_S$ ) to be connected between the SDA/SCL pins and the SDA/SCL bus lines as shown in Figure 45 without exceeding the maximum specified  $t_f$ .
  - Necessary to be backwards compatible with Fast-mode.

7. In Fast-mode Plus, fall time is specified the same for both output stage and bus timing. If series resistors are used, designers should allow for this when considering bus timing.
8. Input filters on the SDA and SCL inputs suppress noise spikes of less than 50ns.
9. If  $V_{DD}$  is switched off, I/O pins of Fast-mode and Fast-mode Plus device must not obstruct the SDA and SCL lines.
10. Special purpose device such as multiplexers and switches may exceed this capacitance because they connect multiple paths together.

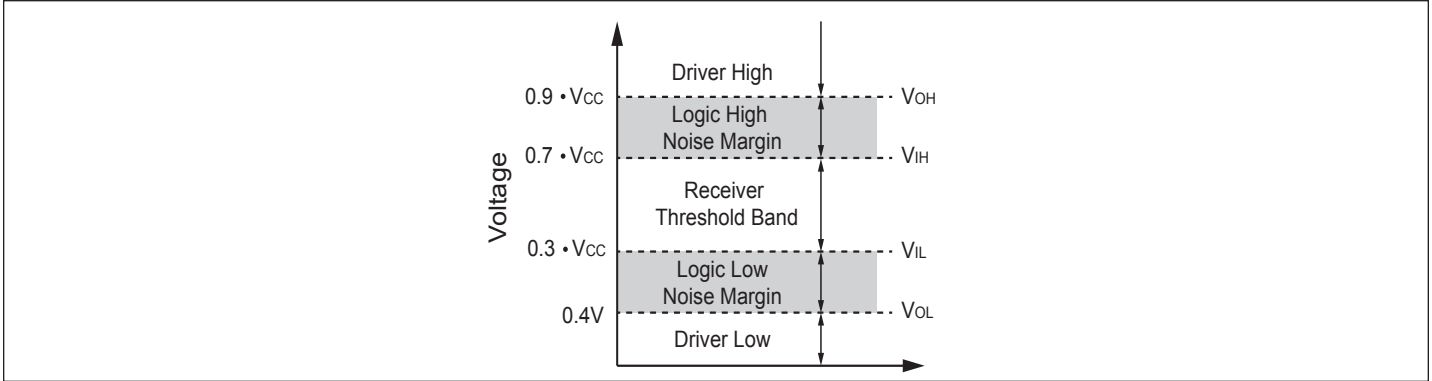


Figure 12. I2C I/O Stage Noise Margin

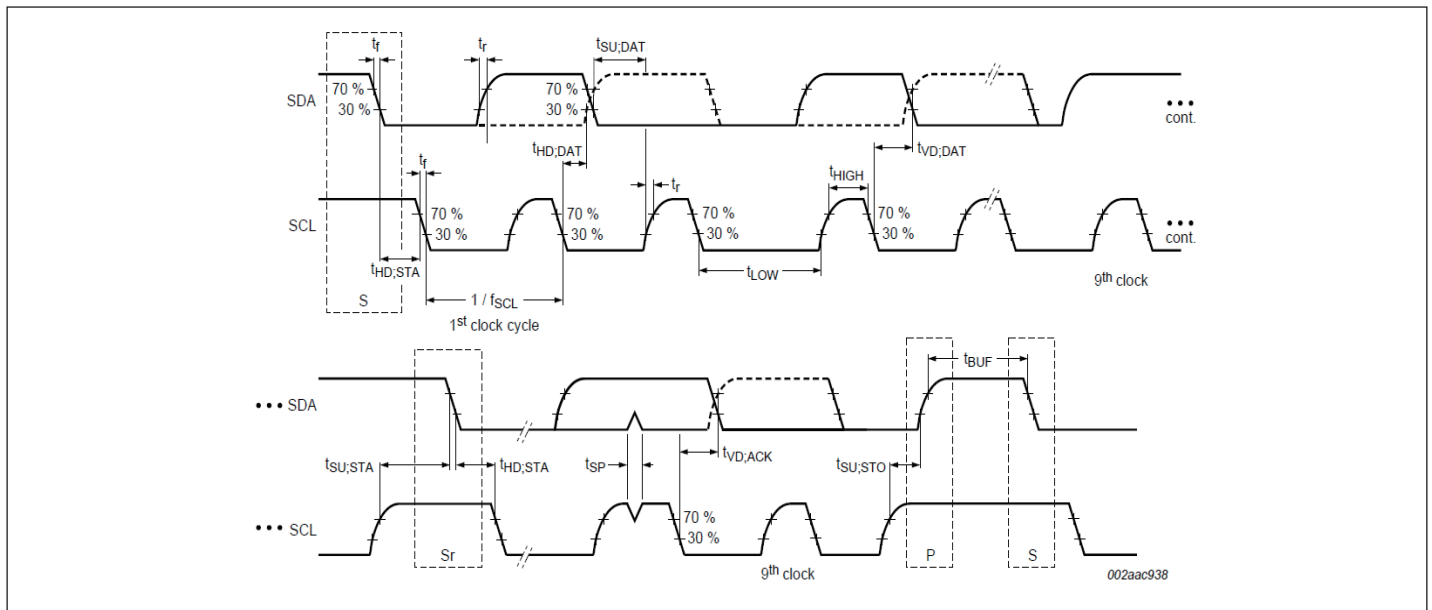
**Characteristics of the SDA and SCL Bus Line for Standard, Fast, and Fast-mode Plus I2C-bus Device <sup>(1)</sup>**

Symbol	Parameter	Conditions	Standard-Mode		Fast-Mode		Fast-Mode Plus		Units
			Min.	Max.	Min.	Max.	Min.	Max.	
$f_{SCL}$	SCL clock frequency		0	100	0	400	0	1000	KHz
$t_{HD;STA}$	Hold time (repeated) START condition	After this period, the first clock pulse is generated.	4.0		0.6		0.26		$\mu s$
$t_{LOW}$	LOW period of the SCL clock		4.7		1.3		0.5		$\mu s$
$t_{HIGH}$	HIGH period of the SCL clock		4.0		0.6		0.26		$\mu s$
$t_{SU;STA}$	Set-up time for a repeated START condition		4.7		0.6		0.26		$\mu s$
$t_{HD;DAT}$	Data hold time <sup>(2)</sup>	CBUS compatible masters	5.0						$\mu s$
		I2C-Bus Devices	0 <sup>(3)</sup>	<sup>(4)</sup>	0 <sup>(3)</sup>	<sup>(4)</sup>	0		
$t_{SU;DAT}$	Data set-up time		250		100 <sup>(5)</sup>		50		ns
$t_r$	Rise time of both SDA and SCL signals			1000	20	300		120	ns
$t_f$	Fall time of both SDA and SCL signals <sup>(3)(6)(7)(8)</sup>			300	$20 \times (V_{DD} / 5.5V)$	300	$20 \times (V_{DD} / 5.5V)$ <sup>(9)</sup>	120 <sup>(8)</sup>	ns
$t_{SU;STO}$	Set-up time for STOP condition		4.0		0.6		0.26		$\mu s$
$t_{BUF}$	Bus free time between a STOP and START condition		4.7		1.3		0.5		$\mu s$
$C_b$	Capacitive load for each bus line <sup>(10)</sup>			400		400		550	pF
$t_{VD;DAT}$	Data valid time <sup>(11)</sup>			3.45 <sup>(4)</sup>		0.9 <sup>(4)</sup>		0.45 <sup>(4)</sup>	$\mu s$

**PI2DPX2063**

Symbol	Parameter	Conditions	Standard-Mode		Fast-Mode		Fast-Mode Plus		Units
			Min.	Max.	Min.	Max.	Min.	Max.	
$t_{VD;ACK}$	Data valid acknowledge time <sup>(12)</sup>			3.45 <sup>(4)</sup>		0.9 <sup>(4)</sup>		0.45 <sup>(4)</sup>	$\mu s$
$V_{nL}$	Noise margin at the LOW level	For each connected device (including hysteresis)	$0.1V_{DD}$		$0.1V_{DD}$		$0.1V_{DD}$		V
$V_{nH}$	Noise margin at the HIGH level	For each connected device (including hysteresis)	$0.2V_{DD}$		$0.2V_{DD}$		$0.2V_{DD}$		V

- Note:
- All values referred to  $V_{IH(min)}$  ( $0.3V_{DD}$ ) and  $V_{IL(max)}$  ( $0.7V_{DD}$ ) levels.
  - $t_{HD;DAT}$  is the data hold time that is measured from the falling edge of SCL, applies to data in transmission and the acknowledge.
  - A device must internally provide a hold time of at least 300ns for the SDA signal (with respect to the  $V_{IH(min)}$  of the SCL signal) to bridge the undefined region of the falling edge of SCL.
  - The maximum  $t_{HD;DAT}$  could be 3.45 $\mu s$  and 0.9 $\mu s$  for Standard-mode and Fast-mode, but must be less than the maximum of  $t_{VD;DAT}$  or  $t_{VD;ACK}$  by a transition time. This maximum must only be met if the device does not stretch the LOW period ( $t_{LOW}$ ) of the SCL signal. If the clock stretches the SCL, the data must be valid by the set-up time before it releases the clock.
  - A Fast-mode I<sup>2</sup>C-bus device can be used in a Standard-mode I<sup>2</sup>C-bus system, but the requirement  $t_{SU;DAT}$  250ns must then be met. This will automatically be the case if the device does not stretch the LOW period of the SCL signal. If such a device does stretch the LOW period of the SCL signal, it must output the next data bit to the SDA line  $t_{r(max)} + t_{SU;DAT} = 1000 + 250 = 1250ns$  (according to the Standard-mode I<sup>2</sup>C-bus specification) before the SCL line is released. Also the acknowledge timing must meet this set-up time.
  - If mixed with HS-mode device, faster fall times according to Table XX are allowed.
  - The maximum  $t_f$  for the SDA and SCL bus lines is specified at 300ns. The maximum fall time for the SDA output stage  $t_f$  is specified are 250ns. This allows series protection resistors to be connected in between the SDA and the SCL pins and the SDA/SCL bus lines without exceeding the maximum specified  $t_f$ .
  - In Fast-mode Plus, fall time is specified the same for both output stage and bus timing. If series resistors are used, designers should allow for this when considering bus timing.
  - Necessary to be backwards compatible to Fast-mode.
  - The maximum bus capacitance allowable may vary from this value depending on the actual operating voltage and frequency of the application. Section XX discusses techniques for coping with higher bus capacitances.
  - $t_{VS;DAT}$  = time for data signal from SCL LOW to SDA output (HIGH or LOW, depending on which one is worse).
  - $t_{VS;ACK}$  = time for Acknowledgement signal from SCL LOW to SDA output (HIGH or LOW, depending on which one is worse).

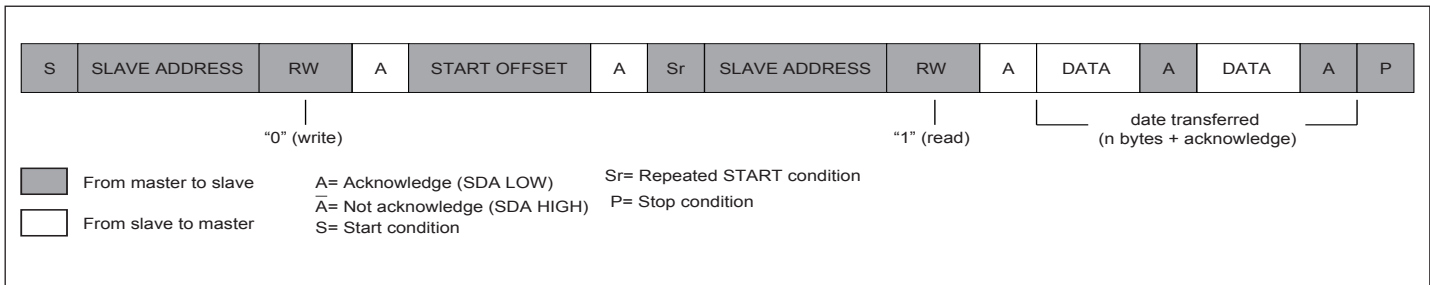


**Figure 13. Definition of Timing for F/S-mode Devices on the I2C Bus**

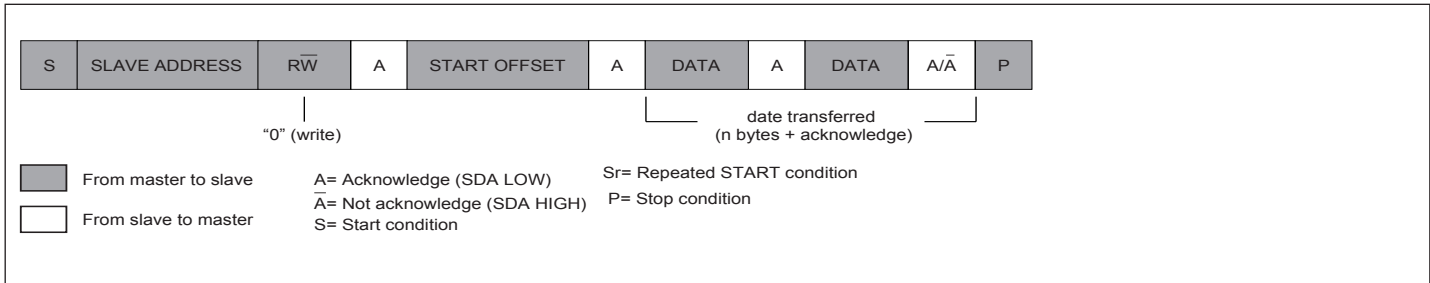
## Detailed Programming Registers

### I2C Slave Address Selections

I2C Slave Address Assignment							
A6	A5	A4	A3	A2	A1	A0	ADDR (Pin 16)
1	0	1	0	0	0	0	L
1	0	1	0	0	0	1	M
1	0	1	0	0	1	0	F
1	0	1	0	0	1	1	H



### Indexed Read



### Indexed Write

### I2C Register Definitions

BYTE 0 (Revision and Vendor ID Register)			
Bit	Type	Power-up Condition	Comment
7	RO	0	Revision ID = 0000
6	RO	0	
5	RO	0	
4	RO	0	
3	RO	0	Diodes ID = 0011
2	RO	0	
1	RO	1	
0	RO	1	

<b>BYTE 1 (Device Type/Device ID Register)</b>			
<b>Bit</b>	<b>Type</b>	<b>Power-up Condition</b>	<b>Comment</b>
7	RO	0	Device Type = Active Mux
6	RO	0	
5	RO	0	
4	RO	1	
3	RO	0	Device ID
2	RO	1	
1	RO	0	
0	RO	0	
<b>BYTE 2 (Byte Count Register 32 Bytes)</b>			
<b>Bit</b>	<b>Type</b>	<b>Power-up Condition</b>	<b>Comment</b>
7	RO	0	I2C Register Byte Count = 32 bytes
6	RO	0	
5	RO	1	
4	RO	0	
3	RO	0	
2	RO	0	
1	RO	0	
0	RO	0	
<b>BYTE 3 (Channel Assignment of RXDET_EN#)</b>			
<b>Bit</b>	<b>Type</b>	<b>Power-up Condition</b>	<b>Comment</b>
7	R/W	0	Operation Mode Setting Refer to Table Configuration Table
6	R/W	0	
5	R/W	1	
4	R/W	0	Reserved
3	R/W	0	Reserved
2	R/W	0	Reserved
1	R/W	0	Reserved
0	R/W	0	Reserved

BYTE 4 (Override the Power Down Control)			
Bit	Type	Power-up Condition	Comment
7	R/W	0	CON3 power down override 0 – Do not force the CON3 to power down state 1 – Force the CON3 to power down state
6	R/W	0	CON2 power down override 0 – Do not force the CON2 to power down state 1 – Force the CON2 to power down state
5	R/W	0	CON1 power down override 0 – Do not force the CON1 to power down state 1 – Force the CON1 to power down state
4	R/W	0	CON0 power down override 0 – Do not force the CON0 to power down state 1 – Force the CON0 to power down state
3	R/W	0	Reserved
2	R/W	1	
1	R/W	0	
0	R/W	0	

BYTE 5 (Equalization and Flat Gain Setting of CON0)			
Bit	Type	Power-up Condition	Comment
7	R/W	0	Reserved
6	R/W	0	CON0_EQ<2> Equalizer setting
5	R/W	0	CON0_EQ<1> Equalizer setting
4	R/W	0	CON0_EQ<0> Equalizer setting
3	R/W	1	CON0_FG<1> Flat gain setting
2	R/W	0	CON0_FG<0> Flat gain setting
1	R/W	0	Reserved
0	R/W	0	Reserved

**PI2DPX2063**

**BYTE 6 (Equalization and Flat Gain Setting of CON1)**

Bit	Type	Power-up Condition	Comment
7	R/W	0	Reserved
6	R/W	0	CON1_EQ<2> Equalizer setting
5	R/W	0	CON1_EQ<1> Equalizer setting
4	R/W	0	CON1_EQ<0> Equalizer setting
3	R/W	1	CON1_FG<1> Flat gain setting
2	R/W	0	CON1_FG<0> Flat gain setting
1	R/W	0	Reserved
0	R/W	0	Reserved

**BYTE 7 (Equalization and Flat Gain Setting of CON2)**

Bit	Type	Power-up Condition	Comment
7	R/W	0	Reserved
6	R/W	0	CON2_EQ<2> Equalizer setting
5	R/W	0	CON2_EQ<1> Equalizer setting
4	R/W	0	CON2_EQ<0> Equalizer setting
3	R/W	1	CON2_FG<1> Flat gain setting
2	R/W	0	CON2_FG<0> Flat gain setting
1	R/W	0	Reserved
0	R/W	0	Reserved

**BYTE 8 (Equalization and Flat Gain Setting of CON3)**

Bit	Type	Power-up Condition	Comment
7	R/W	0	Reserved
6	R/W	0	CON3_EQ<2> Equalizer setting
5	R/W	0	CON3_EQ<1> Equalizer setting
4	R/W	0	CON3_EQ<0> Equalizer setting
3	R/W	1	CON3_FG<1> Flat gain setting
2	R/W	0	CON3_FG<0> Flat gain setting
1	R/W	0	Reserved
0	R/W	0	Reserved

**PI2DPX2063**

<b>BYTE 9 (AUX Flip Control)</b>			
<b>Bit</b>	<b>Type</b>	<b>Power-up Condition</b>	<b>Comment</b>
7	R/W	0	Reserved
6	R/W	0	Reserved
5	R/W	0	Reserved
4	R/W	0	Reserved
3	R/W	0	Reserved
2	R/W	0	Reserved
1	R/W	0	AUX flip for AUXSBU1/2 and AUXP/N 0 – Flip is disabled 1 – Flip is enabled
0	R/W	0	DP FLIP DP flip for ALL CONx channels 0 – DP Flip is Disabled 1 – DP Flip is Enabled

<b>BYTE 10 (Reserved)</b>			
<b>Bit</b>	<b>Type</b>	<b>Power-up Condition</b>	<b>Comment</b>
7	R/W	1	Reserved
6	R/W	1	
5	R/W	1	
4	R/W	1	
3	R/W	1	
2	R/W	1	
1	R/W	0	
0	R/W	0	

<b>BYTE 11 (Reserved)</b>			
<b>Bit</b>	<b>Type</b>	<b>Power-up Condition</b>	<b>Comment</b>
7	R/W	1	Reserved
6	R/W	1	
5	R/W	1	
4	R/W	1	
3	R/W	1	
2	R/W	1	
1	R/W	0	
0	R/W	0	

BYTE 12 (Reserved)			
Bit	Type	Power-up Condition	Comment
7	R/W	0	Reserved
6	R/W	0	
5	R/W	1	
4	R/W	1	
3	R/W	0	
2	R/W	0	
1	R/W	0	
0	R/W	1	

BYTE 13 (Power State of the Channel CON0/1)				
Bit	Type	Power-up Condition	Control Affected	Comment
7	RO	N/A	CON0_State<2>	For the channel operating mode 000 – PD (Power down mode) 001 – PowerON (Power on ramping mode) 010 – UPM_Short (UPM less than 328ms) 011 – UPM_Long (UPM more than 328ms) 100 - UPM_Active (Unplug active mode) 101 - DSM (U1/U2/U3 power saving mode) 110 – SM (Slumber Mode) 111 - AM (active mode)
6	RO	N/A	CON0_State<1>	
5	RO	N/A	CON0_State<0>	
4	RO	N/A	Reserved	
3	RO	N/A	CON1_State<2>	
2	RO	N/A	CON1_State<1>	
1	RO	N/A	CON1_State<0>	
0	RO	N/A	Reserved	

BYTE 14 (Power State of the Channel CON2/3)				
Bit	Type	Power-up Condition	Control Affected	Comment
7	RO	N/A	CON2_State<2>	For the channel operating mode 000 – PD (Power down mode) 001 – PowerON (Power on ramping mode) 010 – UPM_Short (UPM less than 328ms) 011 – UPM_Long (UPM more than 328ms) 100 - UPM_Active (Unplug active mode) 101 - DSM (U1/U2/U3 power saving mode) 110 – SM (Slumber Mode) 111 - AM (active mode)
6	RO	N/A	CON2_State<1>	
5	RO	N/A	CON2_State<0>	
4	RO	N/A	Reserved	
3	RO	N/A	CON3_State<2>	
2	RO	N/A	CON3_State<1>	
1	RO	N/A	CON3_State<0>	
0	RO	N/A	Reserved	

**BYTE 15 (LFPS Detector Monitor and Channel Power Down Monitor)**

Bit	Type	Power-up Condition	Comment
7	RO	N/A	CON3_USB_LFPS#
6	RO	N/A	CON2_USB_LFPS#
5	RO	N/A	CON1_USB_LFPS#
4	RO	N/A	CON0_USB_LFPS#
3	RO	N/A	PD_CON3_MON
2	RO	N/A	PD_CON2_MON
1	RO	N/A	PD_CON1_MON
0	RO	N/A	PD_CON0_MON

Has meaning for USB3.x application only. CONx\_USB\_LFPS#  
 0-LFPS data  
 1-5/10Gbps USB3.x data  
 Monitors the PD condition of each channel.

**BYTE 16 (AUX and HPD Monitor)**

Bit	Type	Power-up Condition	Comment
7	RO	N/A	Reserved
6	RO	N/A	Reserved
5	RO	N/A	AUX_IDLE_DET# Detect the AUX activities "0" – Idle "1" – has activities
4	RO	N/A	DP_HPDP The condition of IN_HPDP 0 – De-asserted 1 – Asserted Notes: When DP_HPDP_PIN_EN#=1, then, this value is 1 always.
3	RO	N/A	AP0_RX_SEL "0" AP0 is TX terminal. "1" AP0 is RX terminal
2	RO	N/A	AP3_RX_SEL "0" AP3 is TX terminal. "1" AP3 is RX terminal
1	RO	N/A	CON0_RX_SEL "0" CON0 is TX terminal. "1" CON0 is RX terminal
0	RO	N/A	CON3_RX_SEL "0" CON3 is TX terminal. "1" CON3 is RX terminal

BYTE 17			
Bit	Type	Power-up Condition	Comment
7	RO	0	Reserved
6	RO	0	
5	RO	0	
4	RO	1	
3	RO	0	
2	RO	1	
1	RO	0	
0	RO	0	

BYTE 18 (DPCD Address 00101h: Lane Count Set)			
Bit	Type	Power-up Condition	Comment
7	RO	0	<p>LANE_COUNT_SET Main-Link Lane Count = Value.</p> <p>Bit&lt;4:0&gt;LANE_COUNT_SET Three values are supported. All other values are RESERVED. Note: Because the upstream device is required to set this value within the MAX_LINK_RATE register (DPCD Address 00001h), there is no power-on reset default value for this field. It is suggested to program this field to 1h. (See the Note within the description for the LINK_BW_SET register (DPCD Address 00100h).)</p> <p>1h = 1 lane (Lane 0 only) 2h = 2 lanes (Lanes 0 and 1 only) 4h = 4 lanes A Source device may choose any lane count as long as it does not exceed the capability of the DPRX.</p> <p>For DPCD Ver.1.0: Bits &lt;7:5&gt; = RESERVED. Read all 0's. For DPCD Ver.1.1: Bits &lt;6:5&gt; = RESERVED. Read all 0's. Bit 7 = ENHANCED_FRAME_EN 0 = Enhanced Framing symbol sequence is not enabled. 1 = Enhanced Framing symbol sequence for BS and SR is enabled. Applicable to SST-only mode. A DPTX must set this bit to 1 when the DPRX has the ENHANCED_FRAME_CAP bit in the MAX_LANE_COUNT register (DPCD Address 00002h, bit 7) set to 1.</p>
6	RO	0	
5	RO	0	
4	RO	0	
3	RO	0	
2	RO	1	
1	RO	0	
0	RO	0	

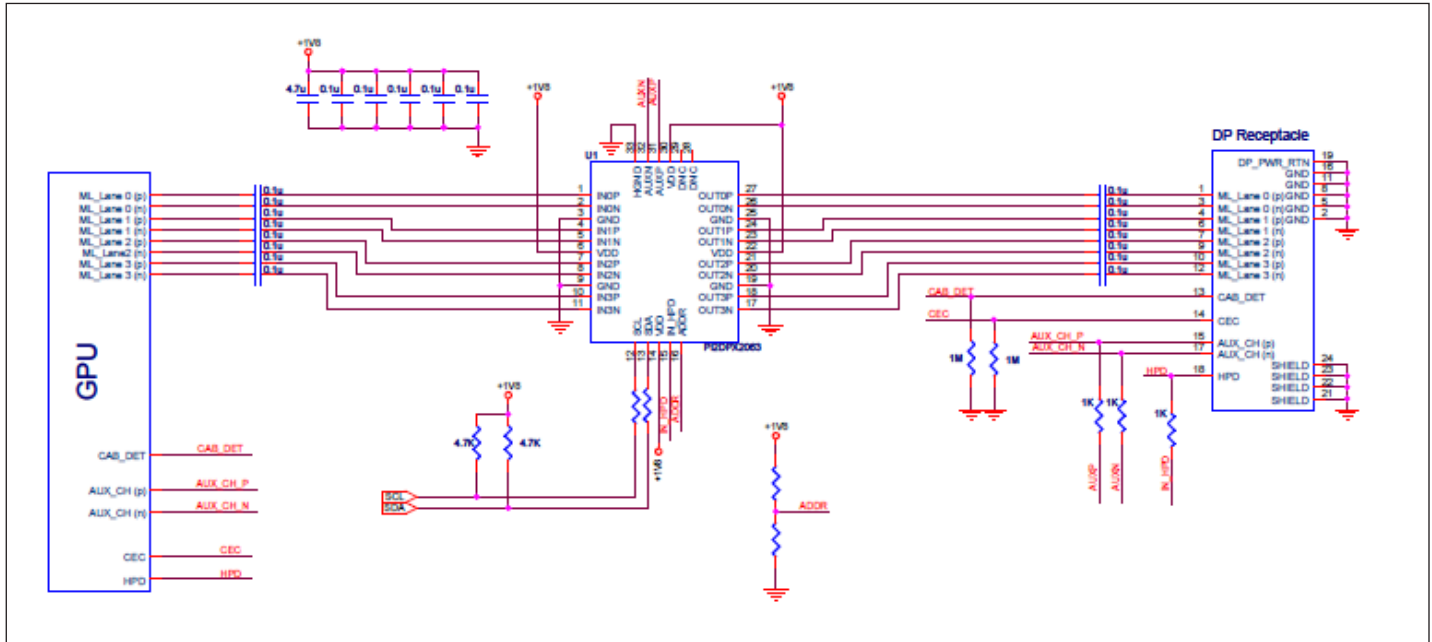
**BYTE 19 - 30 (Reserved)**

**PI2DPX2063**

<b>BYTE 31 (DPCD Address 00600h: SET DP Power)</b>			
<b>Bit</b>	<b>Type</b>	<b>Power-up Condition</b>	<b>Comment</b>
7	RO	0	SET_POWER_STATE
6	RO	0	Bit 2:0 001 = Set local Sink device and all downstream Sink devices to D0 (normal operation mode). 010 = Set local Sink device and all downstream Sink devices to D3 (power-down mode). 101 = Set Main-Link for local Sink device and all downstream Sink devices to D3 (power-down mode), keep AUX block fully powered, ready to reply within a Response Timeout period of 300us. All other values are RESERVED.
5	RO	0	
4	RO	0	
3	RO	0	
2	RO	0	
1	RO	0	
0	RO	1	

**PI2DPX2063**

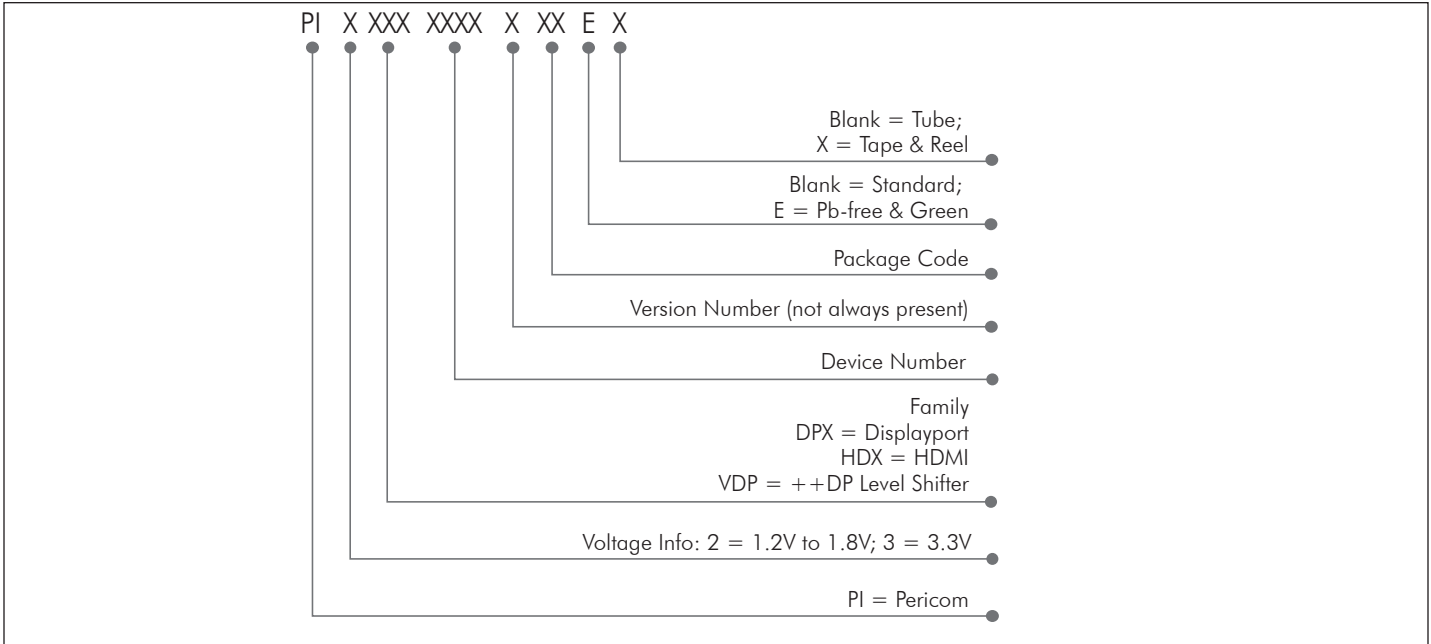
**Application Schematics**



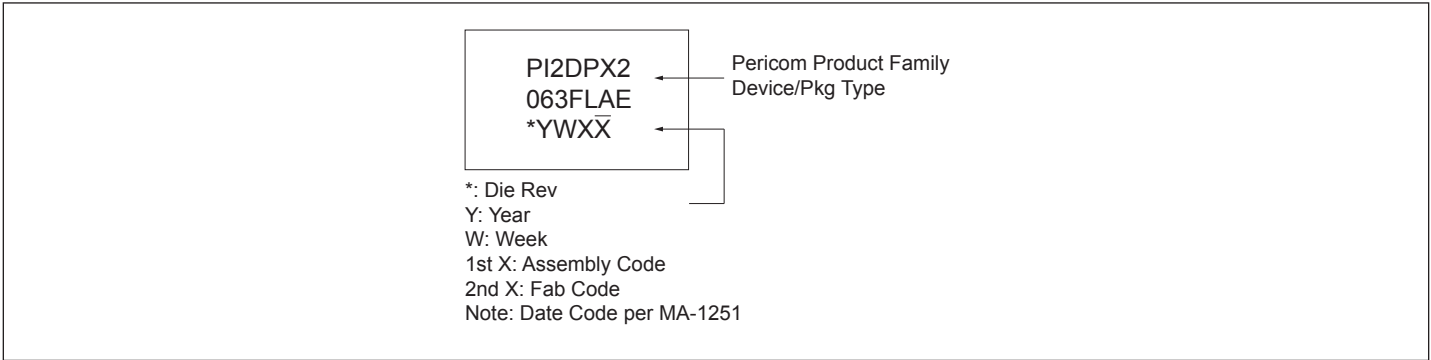


**PI2DPX2063**

**Device Naming Information**



**Part Marking**



## Tape & Reel Materials and Design

### Carrier Tape

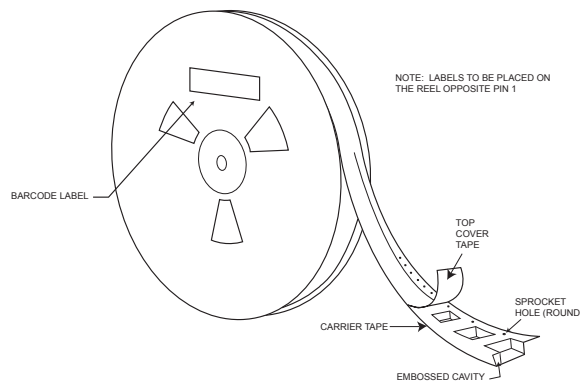
The pocketed carrier tape is made of conductive polystyrene plus carbon material (or equivalent). The surface resistivity is 106Ω/sq. maximum. Pocket tapes are designed so that the component remains in position for automatic handling after cover tape is removed. Each pocket has a hole in the center for automated sensing if the pocket is occupied or not, thus facilitating device removal. Sprocket holes along the edge of the center tape enable direct feeding into automated board assembly equipment. See figures 3 and 4 for carrier tape dimensions.

### Cover Tape

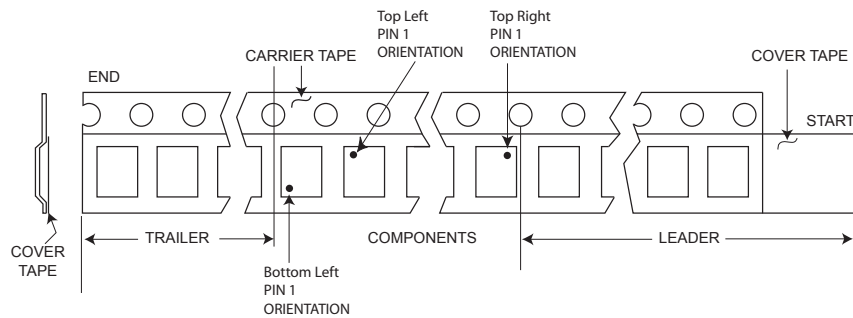
Cover tape is made of anti-static transparent polyester film. The surface resistivity is 107Ω/sq. Minimum to 1011Ω/sq. maximum. The cover tape is heat-sealed to the edges of the carrier tape to encase the devices in the pockets. The force to peel back the cover tape from the carrier tape shall be a MEAN value of 20gm to 80gm (2N to 0.8N).

### Reel

The device loading orientation is in compliance with EIA-481, current version (Figure 2). The loaded carrier tape is wound onto either a 13-inch reel (Figure 4) or 7-inch reel. The reel is made of Antistatic High-Impact Polystyrene. The surface resistivity 107Ω/sq. minimum to 1011Ω/sq. maximum.

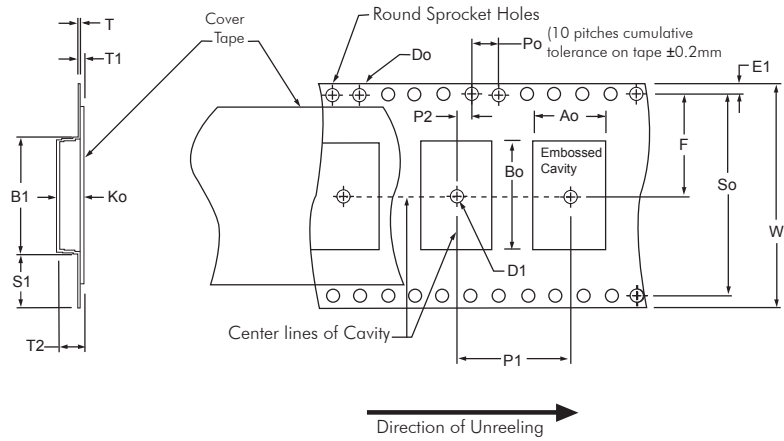


Tape & Reel Label Information



Tape Leader and Trailer Pin 1 Orientations

**PI2DPX2063**



Standard Embossed Carrier Tape Dimensions

**Tape & Reel Dimensions**

Constant Dimensions

TAPE SIZE	D <sub>0</sub>	D <sub>1</sub> (Min)	E <sub>1</sub>	P <sub>0</sub>	P <sub>2</sub>	R <sup>(2)</sup>	S <sub>1</sub> (Min)	T (Max)	T <sub>1</sub> (Max)
8mm	1.5 +0.1-0.0	1.0	1.75 ± 0.1	4.0 ± 0.1	2.0 ± 0.05	25	0.6	0.6	0.1
12mm		1.5							
16mm					2.0 ± 0.1	50			
24mm									
32mm					2.0				
44mm									

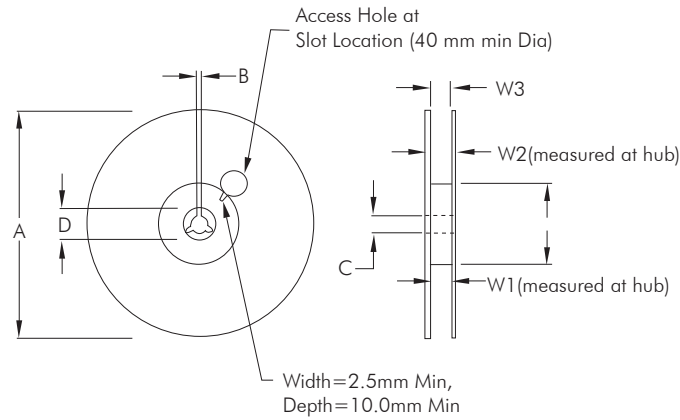
Variable Dimensions

TAPE SIZE	P <sub>1</sub>	B <sub>1</sub> (Max)	E <sub>2</sub> (Min)	F	So	T <sub>2</sub> (Max)	W (Max)	A <sub>0</sub> , B <sub>0</sub> & K <sub>0</sub>
8mm	Specific per package type. Refer to FR-0221 (Tape and Reel Packing Information) or visit <a href="http://www.diodes.com/assets/MediaList-Attachments/Diodes-Tape-Reel-Tube.pdf">www.diodes.com/assets/MediaList-Attachments/Diodes-Tape-Reel-Tube.pdf</a>	4.35	6.25	3.5 ± 0.05	N/A <sup>(4)</sup>	2.5	8.3	See Note 1
12mm		8.2	10.25	5.5 ± 0.05		6.5	12.3	
16mm		12.1	14.25	7.5 ± 0.1		8.0	16.3	
24mm		20.1	22.25	11.5 ± 0.1		12.0	24.3	
32mm		23.0	N/A	14.2 ± 0.1	28.4 ± 0.1	32.3		
44mm		35.0	N/A	20.2 ± 0.15	40.4 ± 0.1	16.0	44.3	

NOTES:

- A<sub>0</sub>, B<sub>0</sub>, and K<sub>0</sub> are determined by component size. The cavity must restrict lateral movement of component to 0.5mm maximum for 8mm and 12mm wide tape and to 1.0mm maximum for 16mm, 24mm, 32mm, and 44mm wide carrier. The maximum component rotation within the cavity must be limited to 20° maximum for 8 and 12 mm carrier tapes and 10° maximum for 16mm through 44mm.
- Tape and components will pass around reel with radius "R" without damage.
- S<sub>1</sub> does not apply to carrier width ≥32mm because carrier has sprocket holes on both sides of carrier where D<sub>0</sub> ≥ S<sub>1</sub>.
- S<sub>0</sub> does not exist for carrier ≤32mm because carrier does not have sprocket hole on both side of carrier.

**PI2DPX2063**



Reel Dimensions By Tape Size

TAPE SIZE	A	N (Min) <sup>(1)</sup>	W <sub>1</sub>	W <sub>2</sub> (Max)	W <sub>3</sub>	B (Min)	C	D (Min)
8mm	178 ± 2.0mm or	60 ± 2.0mm or	8.4 +1.5/-0.0mm	14.4mm	Shall Accommodate Tape Width Without Interference	1.5mm	13.0 +0.5/-0.2 mm	20.2mm
12mm	330 ± 2.0mm	100 ± 2.0mm	12.4 +2.0/-0.0mm	18.4mm				
16mm	330 ± 2.0mm	100 ± 2.0mm	16.4 +2.0/-0.0mm	22.4mm				
24mm			24.4 +2.0/-0.0mm	30.4mm				
32mm			32.4 +2.0/-0.0mm	38.4mm				
44mm			44.4 +2.0/-0.0mm	50.4mm				

NOTE:

1. If reel diameter A=178 ±2.0mm, then the corresponding hub diameter (N(min)) will by 60 ±2.0mm. If reel diameter A=330±2.0mm, then the corresponding hub diameter (N(min)) will by 100±2.0mm.

**IMPORTANT NOTICE**

1. DIODES INCORPORATED (Diodes) AND ITS SUBSIDIARIES MAKE NO WARRANTY OF ANY KIND, EXPRESS OR IMPLIED, WITH REGARDS TO ANY INFORMATION CONTAINED IN THIS DOCUMENT, INCLUDING, BUT NOT LIMITED TO, THE IMPLIED WARRANTIES OF MERCHANTABILITY, FITNESS FOR A PARTICULAR PURPOSE OR NON-INFRINGEMENT OF THIRD PARTY INTELLECTUAL PROPERTY RIGHTS (AND THEIR EQUIVALENTS UNDER THE LAWS OF ANY JURISDICTION).
2. The Information contained herein is for informational purpose only and is provided only to illustrate the operation of Diodes' products described herein and application examples. Diodes does not assume any liability arising out of the application or use of this document or any product described herein. This document is intended for skilled and technically trained engineering customers and users who design with Diodes' products. Diodes' products may be used to facilitate safety-related applications; however, in all instances customers and users are responsible for (a) selecting the appropriate Diodes products for their applications, (b) evaluating the suitability of Diodes' products for their intended applications, (c) ensuring their applications, which incorporate Diodes' products, comply the applicable legal and regulatory requirements as well as safety and functional-safety related standards, and (d) ensuring they design with appropriate safeguards (including testing, validation, quality control techniques, redundancy, malfunction prevention, and appropriate treatment for aging degradation) to minimize the risks associated with their applications.
3. Diodes assumes no liability for any application-related information, support, assistance or feedback that may be provided by Diodes from time to time. Any customer or user of this document or products described herein will assume all risks and liabilities associated with such use, and will hold Diodes and all companies whose products are represented herein or on Diodes' websites, harmless against all damages and liabilities.
4. Products described herein may be covered by one or more United States, international or foreign patents and pending patent applications. Product names and markings noted herein may also be covered by one or more United States, international or foreign trademarks and trademark applications. Diodes does not convey any license under any of its intellectual property rights or the rights of any third parties (including third parties whose products and services may be described in this document or on Diodes' website) under this document.
5. Diodes' products are provided subject to Diodes' Standard Terms and Conditions of Sale (<https://www.diodes.com/about/company/terms-and-conditions/terms-and-conditions-of-sales/>) or other applicable terms. This document does not alter or expand the applicable warranties provided by Diodes. Diodes does not warrant or accept any liability whatsoever in respect of any products purchased through unauthorized sales channel.
6. Diodes' products and technology may not be used for or incorporated into any products or systems whose manufacture, use or sale is prohibited under any applicable laws and regulations. Should customers or users use Diodes' products in contravention of any applicable laws or regulations, or for any unintended or unauthorized application, customers and users will (a) be solely responsible for any damages, losses or penalties arising in connection therewith or as a result thereof, and (b) indemnify and hold Diodes and its representatives and agents harmless against any and all claims, damages, expenses, and attorney fees arising out of, directly or indirectly, any claim relating to any noncompliance with the applicable laws and regulations, as well as any unintended or unauthorized application.
7. While efforts have been made to ensure the information contained in this document is accurate, complete and current, it may contain technical inaccuracies, omissions and typographical errors. Diodes does not warrant that information contained in this document is error-free and Diodes is under no obligation to update or otherwise correct this information. Notwithstanding the foregoing, Diodes reserves the right to make modifications, enhancements, improvements, corrections or other changes without further notice to this document and any product described herein. This document is written in English but may be translated into multiple languages for reference. Only the English version of this document is the final and determinative format released by Diodes.
8. Any unauthorized copying, modification, distribution, transmission, display or other use of this document (or any portion hereof) is prohibited. Diodes assumes no responsibility for any losses incurred by the customers or users or any third parties arising from any such unauthorized use.
9. This Notice may be periodically updated with the most recent version available at <https://www.diodes.com/about/company/terms-and-conditions/important-notice>

DIODES is a trademark of Diodes Incorporated in the United States and other countries.

The Diodes logo is a registered trademark of Diodes Incorporated in the United States and other countries.

© 2022 Diodes Incorporated. All Rights Reserved.

[www.diodes.com](http://www.diodes.com)

# Mouser Electronics

Authorized Distributor

Click to View Pricing, Inventory, Delivery & Lifecycle Information:

[Diodes Incorporated:](#)

[PI2DPX2063FLAEX](#)

## Looking for pricing, stock, or lifecycle information?

Click below to explore more details on WIN SOURCE:

 [View PI2DPX2063FLAEX on WIN SOURCE](#)

 [Diodes Incorporated](#) Information

## Optimize Your Supply Chain with WIN SOURCE Solutions

-  Global Sourcing Solution
-  Obsolete Management
-  Cost Control Management
-  Shortage Management
-  Alternative Solution
-  Excess Inventory Management