



**THE DATASHEET OF
INA190A4IDCKR**



INA190 Bidirectional, Low-Power, Zero-Drift, Wide Dynamic Range, Precision Current-Sense Amplifier With Enable

1 Features

- Low input bias currents: 500 pA (typ) (enables microamp current measurement)
- Low power:
 - Low supply voltage, V_S : 1.7 V to 5.5 V
 - Low shutdown current: 100 nA (max)
 - Low quiescent current: 50 μ A at 25°C (typ)
- Accuracy:
 - Common-mode rejection ratio: 132 dB (min)
 - Gain error: $\pm 0.2\%$ (A1 device)
 - Gain drift: 7 ppm/°C (max)
 - Offset voltage, V_{OS} : ± 15 μ V (max)
 - Offset drift: 80 nV/°C (max)
- Wide common-mode voltage: -0.2 V to +40 V
- Bidirectional current sensing capability
- Gain options:
 - INA190A1: 25 V/V
 - INA190A2: 50 V/V
 - INA190A3: 100 V/V
 - INA190A4: 200 V/V
 - INA190A5: 500 V/V

2 Applications

- [Standard notebook PC](#)
- [Smartphone](#)
- [Consumer battery charger](#)
- [Baseband unit \(BBU\)](#)
- [Merchant network and server PSU](#)
- [Battery test](#)

3 Description

The INA190 is a low-power, voltage-output, current-shunt monitor (also called a current-sense amplifier). This device is commonly used for overcurrent protection, precision current measurement for system optimization, or in closed-loop feedback circuits. The INA190 can sense drops across shunts at common-mode voltages from -0.2 V to +40 V, independent of the supply voltage.

The low input bias current of the device permits the use of larger current-sense resistors, thus providing accurate current measurements in the microamp range. The low offset voltage of the zero-drift architecture extends the dynamic range of the current measurement. This feature allows for smaller sense resistors with lower power loss, while still providing accurate current measurements.

The INA190 operates from a single 1.7-V to 5.5-V power supply, and draws a maximum of 65 μ A of supply current when enabled; only 0.1 μ A when disabled. Five fixed gain options are available: 25 V/V, 50 V/V, 100 V/V, 200 V/V, or 500 V/V. The device is specified over the operating temperature range of -40 °C to +125°C, and offered in UQFN, SC70, and SOT-23 packages.

Device Information⁽¹⁾

PART NUMBER	PACKAGE	BODY SIZE (NOM)
INA190	SC70 (6)	2.00 mm x 1.25 mm
	SOT-23 (8)	1.60 mm x 2.90 mm
	UQFN (10)	1.80 mm x 1.40 mm

(1) For all available packages, see the package option addendum at the end of the datasheet.

Typical Application

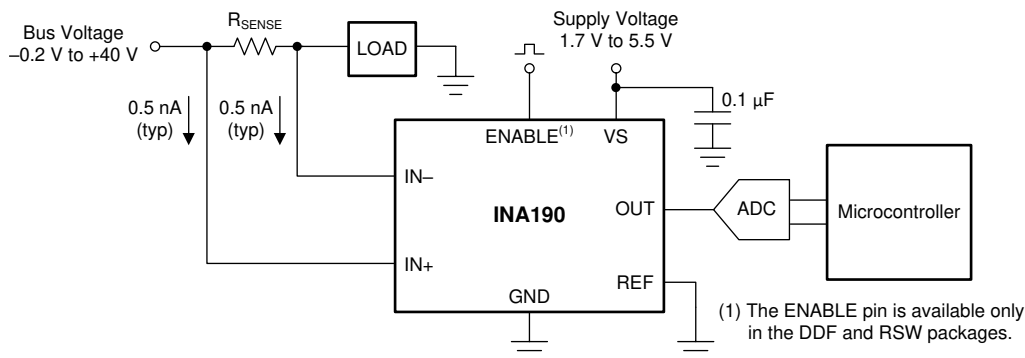

Table of Contents

1 Features	1	7.4 Device Functional Modes.....	16
2 Applications	1	8 Application and Implementation	20
3 Description	1	8.1 Application Information.....	20
4 Revision History	2	8.2 Typical Applications	25
5 Pin Configuration and Functions	3	9 Power Supply Recommendations	26
6 Specifications	4	10 Layout	27
6.1 Absolute Maximum Ratings	4	10.1 Layout Guidelines	27
6.2 ESD Ratings.....	4	10.2 Layout Examples.....	27
6.3 Recommended Operating Conditions.....	4	11 Device and Documentation Support	30
6.4 Thermal Information	4	11.1 Documentation Support	30
6.5 Electrical Characteristics.....	5	11.2 Receiving Notification of Documentation Updates	30
6.6 Typical Characteristics	7	11.3 Support Resources	30
7 Detailed Description	13	11.4 Trademarks	30
7.1 Overview	13	11.5 Electrostatic Discharge Caution.....	30
7.2 Functional Block Diagram	13	11.6 Glossary	30
7.3 Feature Description.....	14	12 Mechanical, Packaging, and Orderable Information	30

4 Revision History

NOTE: Page numbers for previous revisions may differ from page numbers in the current version.

Changes from Revision C (April 2019) to Revision D Page

- Added DDF (SOT-23-8) package and associated content to data sheet 1
- Changed gain drift and offset drift accuracy bullets to match values in the *Electrical Characteristics* table..... 1

Changes from Revision B (September 2018) to Revision C Page

- Added DCK (SC70) package to data sheet..... 1
- Changed front page for clarity
- Changed all instances of V_{VS} to V_S for consistency
- Changed section title from *Output Signal Conditioning* to *Signal Conditioning* and reworded section for clarity 22
- Changed Figure 41, *Differential Input Impedance vs Temperature*, to reflect improved device performance..... 22
- Changed location of *Common-Mode Voltage Transients* section from *Power Supply Recommendations* to *Application and Implementation* 24

Changes from Revision A (June 2018) to Revision B Page

- Changed device status from Advance Information to Production Data..... 1

5 Pin Configuration and Functions

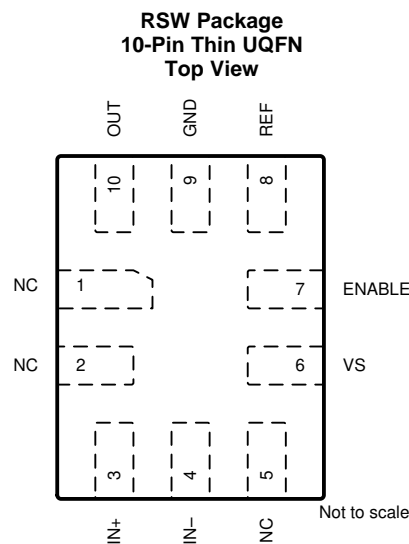
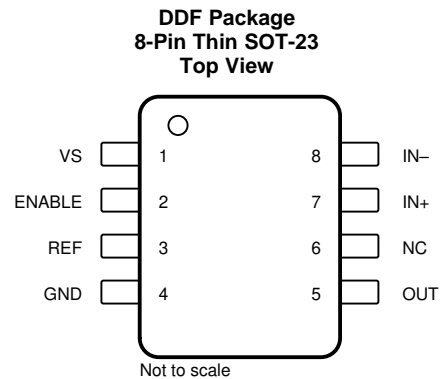
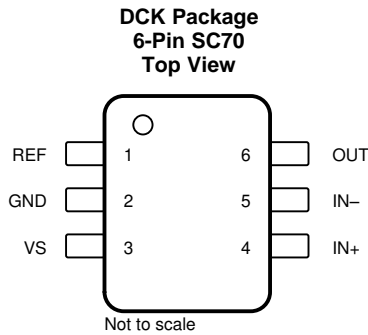

Pin Functions

NAME	PIN			TYPE	DESCRIPTION
	DCK	DDF	RSW		
ENABLE	—	2	7	Digital input	Enable pin. When this pin is driven to V_S , the device is on and functions as a current sense amplifier. When this pin is driven to GND, the device is off, the supply current is reduced, and the output is placed in a high-impedance state. This pin must be driven externally, or connected to V_S if not used. DDF and RSW packages only.
GND	2	4	9	Analog	Ground
IN-	5	8	4	Analog input	Current-sense amplifier negative input. For high-side applications, connect to load side of sense resistor. For low-side applications, connect to ground side of sense resistor.
IN+	4	7	3	Analog input	Current-sense amplifier positive input. For high-side applications, connect to bus voltage side of sense resistor. For low-side applications, connect to load side of sense resistor.
NC	—	6	1, 2, 5	—	Not internally connected. Either float these pins or connect to any voltage between GND and V_S .
OUT	6	5	10	Analog output	OUT pin. This pin provides an analog voltage output that is the gained up voltage difference from the IN+ to the IN- pins, and is offset by the voltage applied to the REF pin.
REF	1	3	8	Analog input	Reference input. Enables bidirectional current sensing with an externally applied voltage.
V_S	3	1	6	Analog	Power supply, 1.7 V to 5.5 V

6 Specifications

6.1 Absolute Maximum Ratings

over operating free-air temperature range (unless otherwise noted)⁽¹⁾

		MIN	MAX	UNIT	
V _S	Supply voltage		6	V	
V _{IN+} , V _{IN-}	Analog inputs	Differential (V _{IN+}) – (V _{IN-}) ⁽²⁾	–42	42	V
		V _{IN+} , V _{IN-} , with respect to GND ⁽³⁾	GND – 0.3	42	
V _{ENABLE}	ENABLE	GND – 0.3	6	V	
	REF, OUT ⁽³⁾	GND – 0.3	(V _S) + 0.3	V	
	Input current into any pin ⁽³⁾		5	mA	
T _A	Operating temperature	–55	150	°C	
T _J	Junction temperature		150	°C	
T _{stg}	Storage temperature	–65	150	°C	

- (1) Stresses beyond those listed under *Absolute Maximum Ratings* may cause permanent damage to the device. These are stress ratings only, which do not imply functional operation of the device at these or any other conditions beyond those indicated under *Recommended Operating Conditions*. Exposure to absolute-maximum-rated conditions for extended periods may affect device reliability.
- (2) V_{IN+} and V_{IN-} are the voltages at the IN+ and IN– pins, respectively.
- (3) Input voltage at any pin may exceed the voltage shown if the current at that pin is limited to 5 mA.

6.2 ESD Ratings

		VALUE	UNIT
V _(ESD)	Electrostatic discharge	Human-body model (HBM), per ANSI/ESDA/JEDEC JS-001 ⁽¹⁾	±3000
		Charged-device model (CDM), per JEDEC specification JESD22-C101 ⁽²⁾	±1000

- (1) JEDEC document JEP155 states that 500-V HBM allows safe manufacturing with a standard ESD control process.
- (2) JEDEC document JEP157 states that 250-V CDM allows safe manufacturing with a standard ESD control process.

6.3 Recommended Operating Conditions

over operating free-air temperature range (unless otherwise noted)

		MIN	NOM	MAX	UNIT
V _{CM}	Common-mode input range	GND – 0.2		40	V
V _{IN+} , V _{IN-}	Input pin voltage range	GND – 0.2		40	V
V _S	Operating supply voltage	1.7		5.5	V
V _{REF}	Reference pin voltage range	GND		V _S	V
T _A	Operating free-air temperature	–40		125	°C

6.4 Thermal Information

THERMAL METRIC ⁽¹⁾		INA190			UNIT
		DCK (SC70)	DDF (SOT23)	RSW (UQFN)	
		6 PINS	8 PINS	10 PINS	
R _{θJA}	Junction-to-ambient thermal resistance	137.2	170.7	163.8	°C/W
R _{θJC(top)}	Junction-to-case (top) thermal resistance	38.4	132.7	78.7	°C/W
R _{θJB}	Junction-to-board thermal resistance	57.1	65.3	93.3	°C/W
Ψ _{JT}	Junction-to-top characterization parameter	5.1	45.7	4.1	°C/W
Ψ _{JB}	Junction-to-board characterization parameter	56.6	65.2	92.8	°C/W
R _{θJC(bot)}	Junction-to-case (bottom) thermal resistance	N/A	N/A	N/A	°C/W

- (1) For more information about traditional and new thermal metrics, see the [Semiconductor and IC Package Thermal Metrics](#) application report.

6.5 Electrical Characteristics

at $T_A = 25^\circ\text{C}$, $V_{\text{SENSE}} = V_{\text{IN}+} - V_{\text{IN}-}$, $V_S = 1.8\text{ V to }5.0\text{ V}$, $V_{\text{IN}+} = 12\text{ V}$, $V_{\text{REF}} = V_S / 2$, and $V_{\text{ENABLE}} = V_S$ (unless otherwise noted)

PARAMETER		CONDITIONS	MIN	TYP	MAX	UNIT
INPUT						
CMRR	Common-mode rejection ratio	$V_{\text{SENSE}} = 0\text{ mV}$, $V_{\text{IN}+} = -0.1\text{ V to }40\text{ V}$, $T_A = -40^\circ\text{C to }+125^\circ\text{C}$	132	150		dB
V_{OS}	Offset voltage, RTI ⁽¹⁾	$V_S = 1.8\text{ V}$, $V_{\text{SENSE}} = 0\text{ mV}$		-3	±15	µV
dV_{OS}/dT	Offset drift, RTI	$V_{\text{SENSE}} = 0\text{ mV}$, $T_A = -40^\circ\text{C to }+125^\circ\text{C}$		10	80	nV/°C
PSRR	Power-supply rejection ratio, RTI	$V_{\text{SENSE}} = 0\text{ mV}$, $V_S = 1.7\text{ V to }5.5\text{ V}$		-1	±5	µV/V
I_{IB}	Input bias current	$V_{\text{SENSE}} = 0\text{ mV}$		0.5	3	nA
I_{IO}	Input offset current	$V_{\text{SENSE}} = 0\text{ mV}$		±0.07		nA
OUTPUT						
G	Gain	A1 devices		25		V/V
		A2 devices		50		
		A3 devices		100		
		A4 devices		200		
		A5 devices		500		
E_G	Gain error	$V_{\text{OUT}} = 0.1\text{ V to }V_S - 0.1\text{ V}$	A1 devices	-0.04%	±0.2%	
			A2, A3, A4 devices	-0.06%	±0.3%	
			A5 devices	-0.08%	±0.4%	
	Gain error drift	$T_A = -40^\circ\text{C to }+125^\circ\text{C}$		2	7	ppm/°C
	Nonlinearity error	$V_{\text{OUT}} = 0.1\text{ V to }V_S - 0.1\text{ V}$		±0.01%		
RVRR	Reference voltage rejection ratio	$V_{\text{REF}} = 100\text{ mV to }V_S - 100\text{ mV}$, $T_A = -40^\circ\text{C to }+125^\circ\text{C}$	A1 devices	±2	±10	µV/V
			A2 devices	±1	±6	
			A3 devices	±0.5	±4	
			A4, A5 devices	±0.25	±3	
	Maximum capacitive load	No sustained oscillation		1		nF
VOLTAGE OUTPUT						
V_{SP}	Swing to V_S power-supply rail	$V_S = 1.8\text{ V}$, $R_L = 10\text{ k}\Omega$ to GND, $T_A = -40^\circ\text{C to }+125^\circ\text{C}$		$(V_S) - 20$	$(V_S) - 40$	mV
V_{SN}	Swing to GND	$V_S = 1.8\text{ V}$, $R_L = 10\text{ k}\Omega$ to GND, $T_A = -40^\circ\text{C to }+125^\circ\text{C}$, $V_{\text{SENSE}} = -10\text{ mV}$, $V_{\text{REF}} = 0\text{ V}$		$(V_{\text{GND}}) + 0.05$	$(V_{\text{GND}}) + 1$	mV
V_{ZL}	Zero current output voltage	$V_S = 1.8\text{ V}$, $R_L = 10\text{ k}\Omega$ to GND, $T_A = -40^\circ\text{C to }+125^\circ\text{C}$, $V_{\text{SENSE}} = 0\text{ mV}$, $V_{\text{REF}} = 0\text{ V}$	A1, A2, A3 devices	$(V_{\text{GND}}) + 1$	$(V_{\text{GND}}) + 3$	mV
			A4 devices	$(V_{\text{GND}}) + 2$	$(V_{\text{GND}}) + 4$	mV
			A5 devices	$(V_{\text{GND}}) + 3$	$(V_{\text{GND}}) + 9$	mV
FREQUENCY RESPONSE						
BW	Bandwidth	A1 devices, $C_{\text{LOAD}} = 10\text{ pF}$		45		kHz
		A2 devices, $C_{\text{LOAD}} = 10\text{ pF}$		37		
		A3 devices, $C_{\text{LOAD}} = 10\text{ pF}$		35		
		A4 devices, $C_{\text{LOAD}} = 10\text{ pF}$		33		
		A5 devices, $C_{\text{LOAD}} = 10\text{ pF}$		27		
SR	Slew rate	$V_S = 5.0\text{ V}$, $V_{\text{OUT}} = 0.5\text{ V to }4.5\text{ V}$		0.3		V/µs
t_s	Settling time	From current step to within 1% of final value		30		µs

(1) RTI = referred-to-input.

Electrical Characteristics (continued)

 at $T_A = 25^\circ\text{C}$, $V_{\text{SENSE}} = V_{\text{IN}+} - V_{\text{IN}-}$, $V_S = 1.8\text{ V to } 5.0\text{ V}$, $V_{\text{IN}+} = 12\text{ V}$, $V_{\text{REF}} = V_S / 2$, and $V_{\text{ENABLE}} = V_S$ (unless otherwise noted)

PARAMETER	CONDITIONS	MIN	TYP	MAX	UNIT
NOISE, RTI⁽¹⁾					
	Voltage noise density		75		nV/ $\sqrt{\text{Hz}}$
ENABLE					
I_{EN}	Leakage input current	$0\text{ V} \leq V_{\text{ENABLE}} \leq V_S$	1	100	nA
V_{IH}	High-level input voltage		$0.7 \times V_S$	6	V
V_{IL}	Low-level input voltage		0	$0.3 \times V_S$	V
V_{HYS}	Hysteresis		300		mV
I_{ODIS}	Output leakage disabled	$V_S = 5.0\text{ V}$, $V_{\text{OUT}} = 0\text{ V to } 5.0\text{ V}$, $V_{\text{ENABLE}} = 0\text{ V}$	1	5	μA
POWER SUPPLY					
I_{Q}	Quiescent current	$V_S = 1.8\text{ V}$, $V_{\text{SENSE}} = 0\text{ mV}$	48	65	μA
		$V_S = 1.8\text{ V}$, $V_{\text{SENSE}} = 0\text{ mV}$, $T_A = -40^\circ\text{C to } +125^\circ\text{C}$		90	μA
I_{QDIS}	Quiescent current disabled	$V_{\text{ENABLE}} = 0\text{ V}$, $V_{\text{SENSE}} = 0\text{ mV}$	10	100	nA

6.6 Typical Characteristics

at $T_A = 25^\circ\text{C}$, $V_S = 1.8\text{ V}$, $V_{IN+} = 12\text{ V}$, $V_{REF} = V_S / 2$, $V_{ENABLE} = V_S$, and for all gain options (unless otherwise noted)

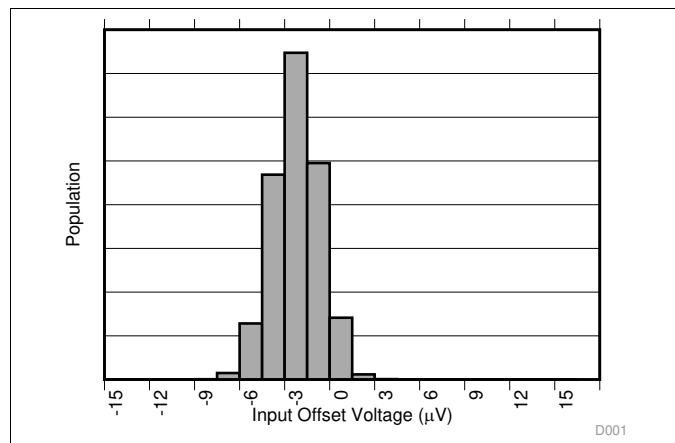

Figure 1. Input Offset Voltage Production Distribution

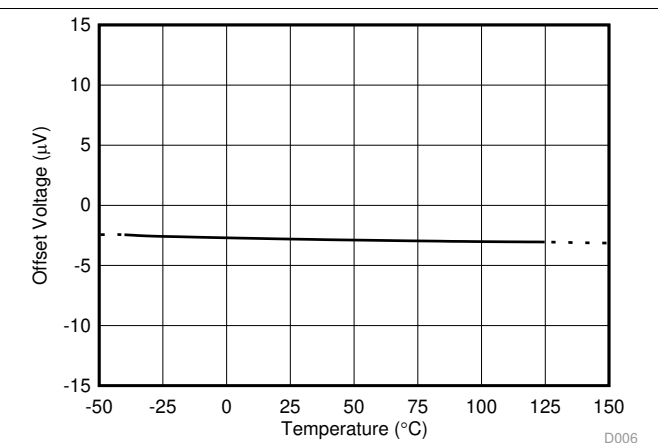

Figure 2. Offset Voltage vs Temperature

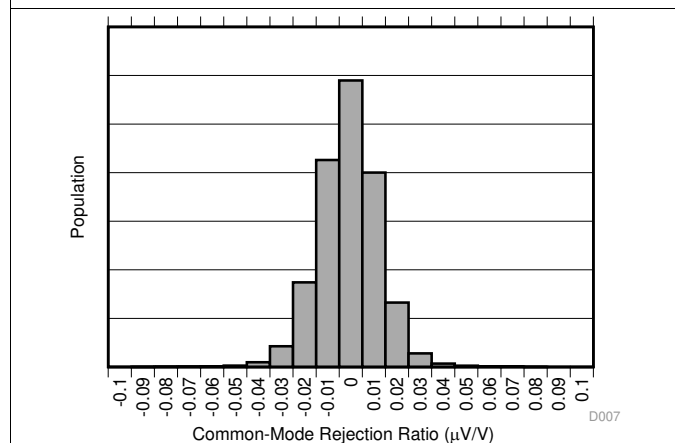

Figure 3. Common-Mode Rejection Production Distribution

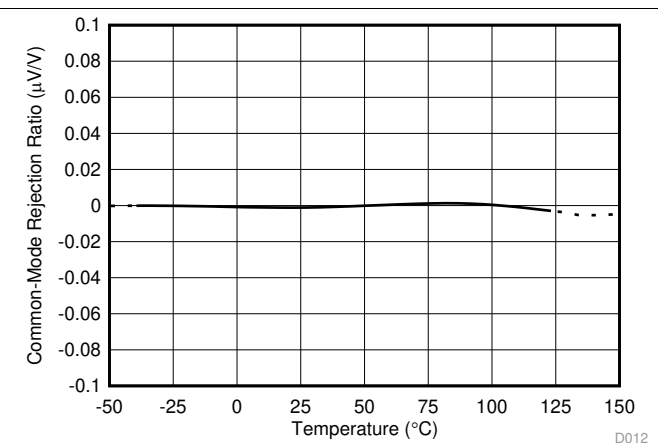

Figure 4. Common-Mode Rejection Ratio vs Temperature

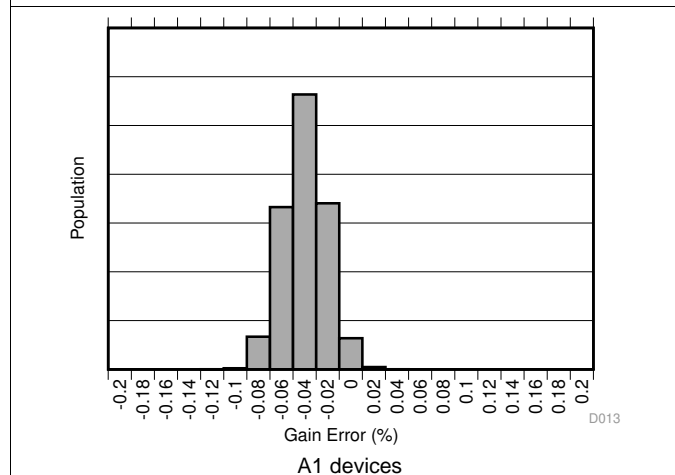

Figure 5. Gain Error Production Distribution

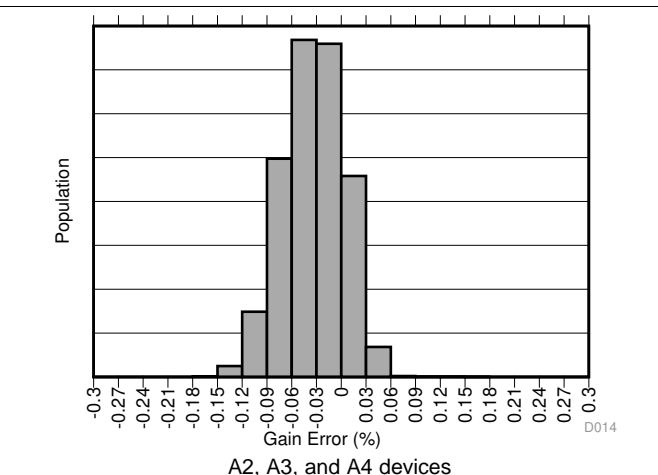
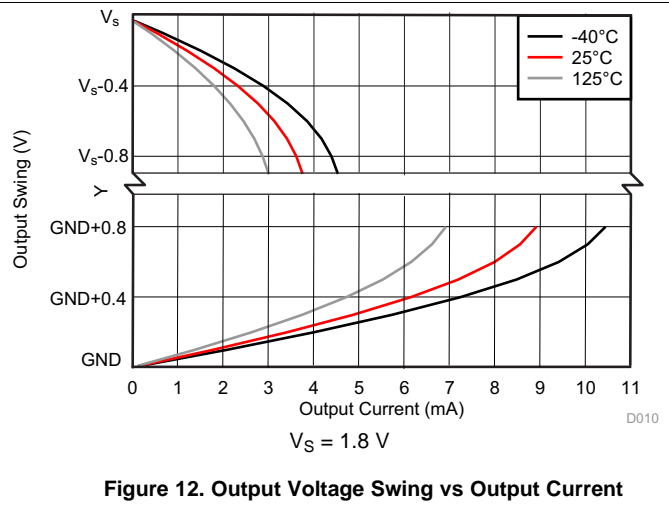
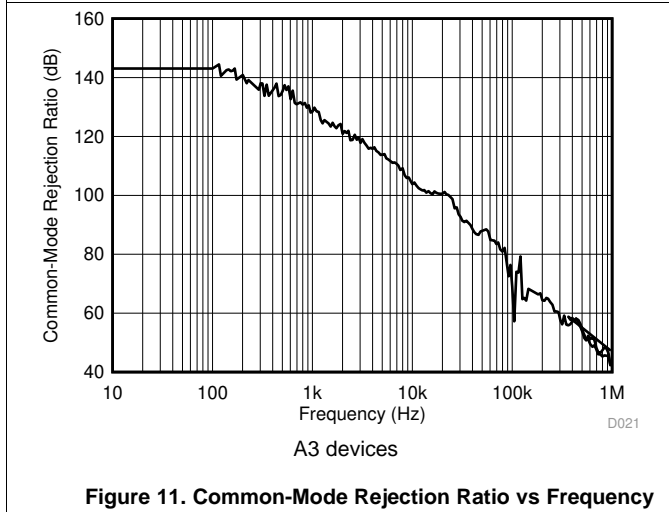
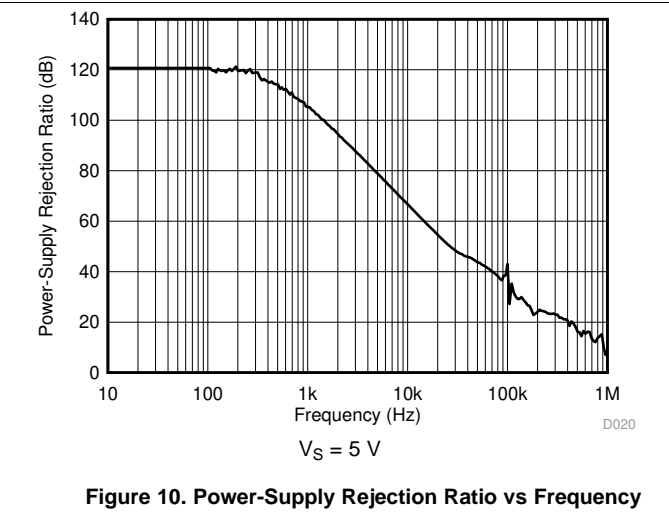
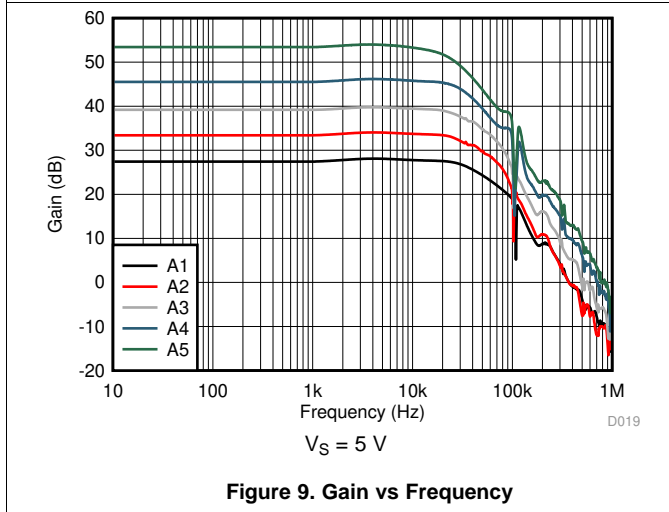
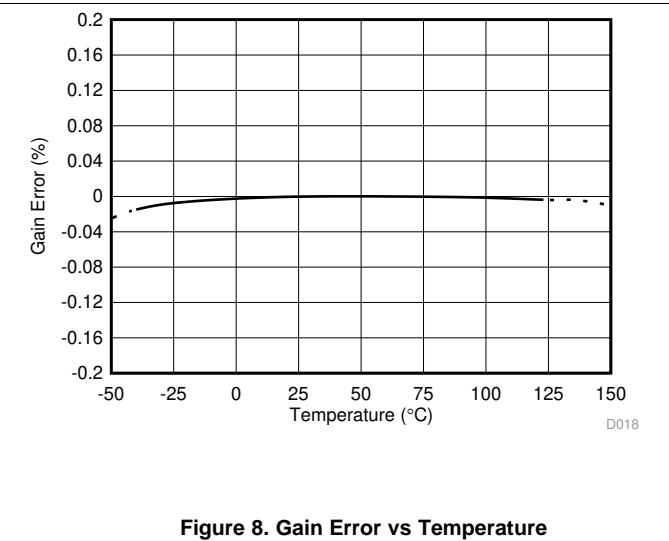
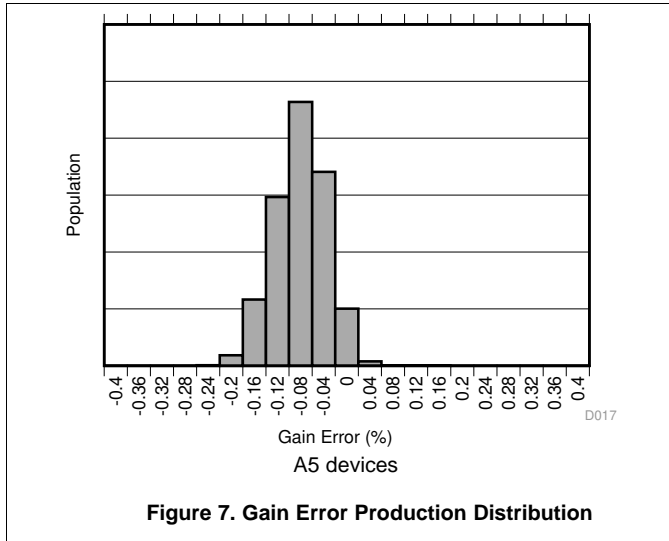

Figure 6. Gain Error Production Distribution

Typical Characteristics (continued)

at $T_A = 25^\circ\text{C}$, $V_S = 1.8\text{ V}$, $V_{IN+} = 12\text{ V}$, $V_{REF} = V_S / 2$, $V_{ENABLE} = V_S$, and for all gain options (unless otherwise noted)



Typical Characteristics (continued)

at $T_A = 25^\circ\text{C}$, $V_S = 1.8\text{ V}$, $V_{IN+} = 12\text{ V}$, $V_{REF} = V_S / 2$, $V_{ENABLE} = V_S$, and for all gain options (unless otherwise noted)

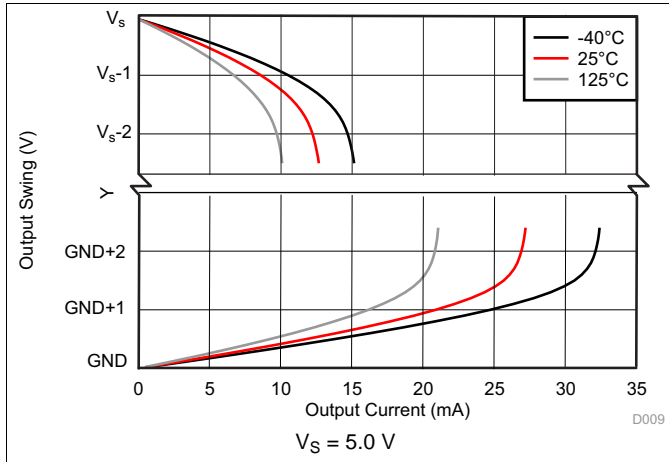

Figure 13. Output Voltage Swing vs Output Current

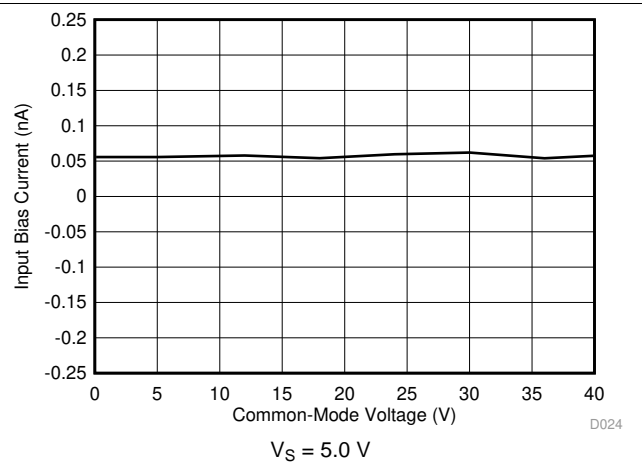

Figure 14. Input Bias Current vs Common-Mode Voltage

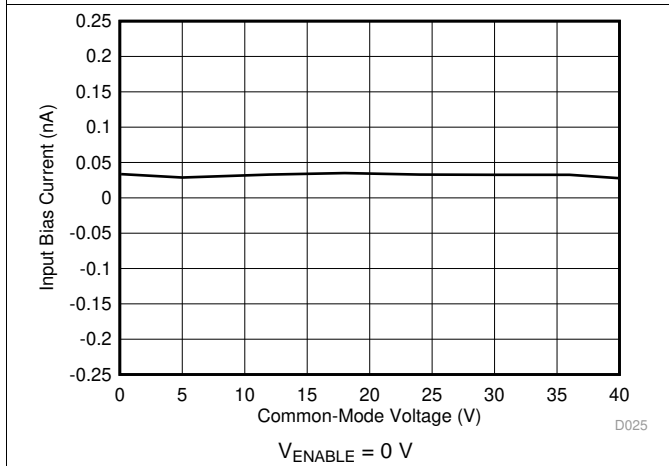

Figure 15. Input Bias Current vs Common-Mode Voltage (Shutdown)

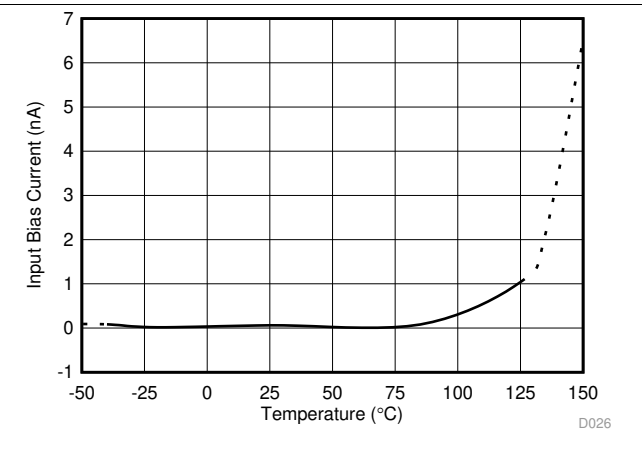

Figure 16. Input Bias Current vs Temperature

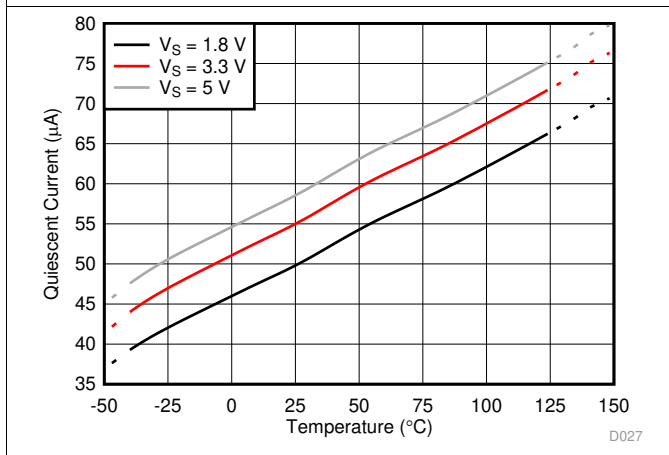

Figure 17. Quiescent Current vs Temperature (Enabled)

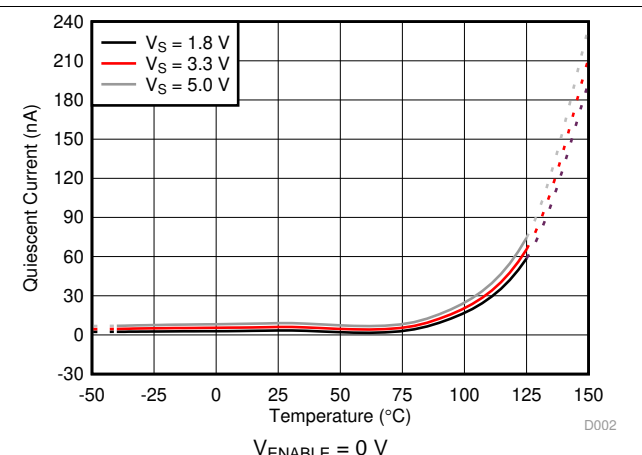

Figure 18. Quiescent Current vs Temperature (Disabled)

Typical Characteristics (continued)

at $T_A = 25^\circ\text{C}$, $V_S = 1.8\text{ V}$, $V_{IN+} = 12\text{ V}$, $V_{REF} = V_S / 2$, $V_{ENABLE} = V_S$, and for all gain options (unless otherwise noted)

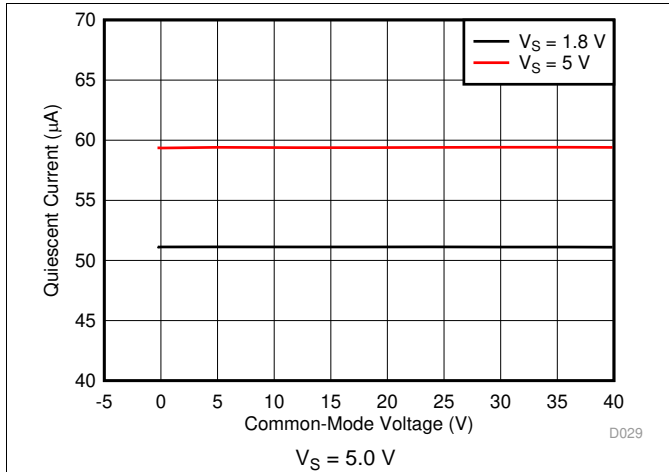

Figure 19. Quiescent Current vs Common Mode Voltage

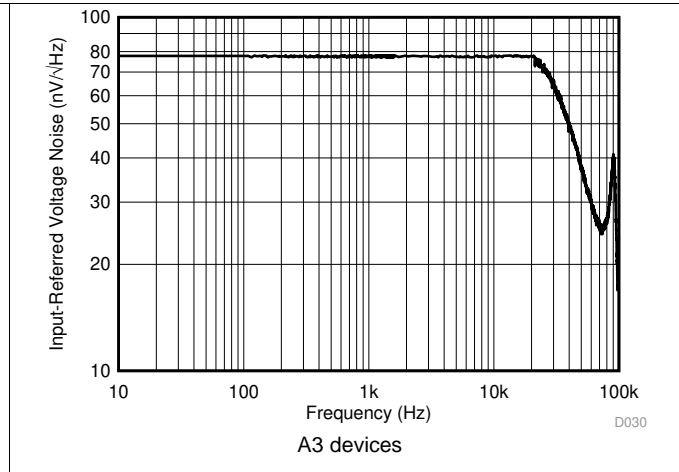

Figure 20. Input-Referred Voltage Noise vs Frequency

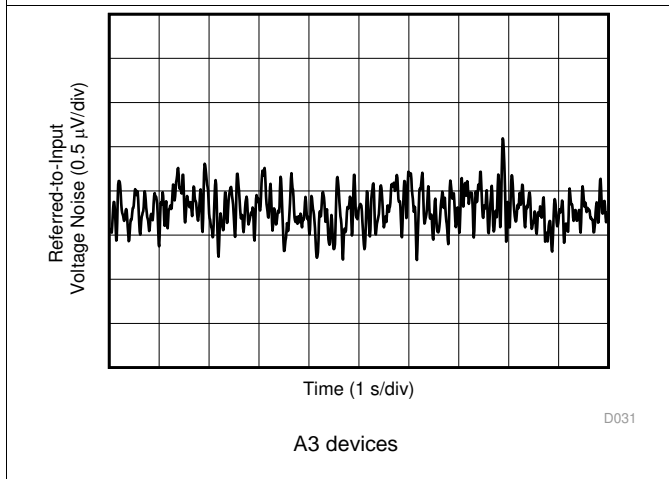

Figure 21. 0.1-Hz to 10-Hz Voltage Noise (Referred-To-Input)

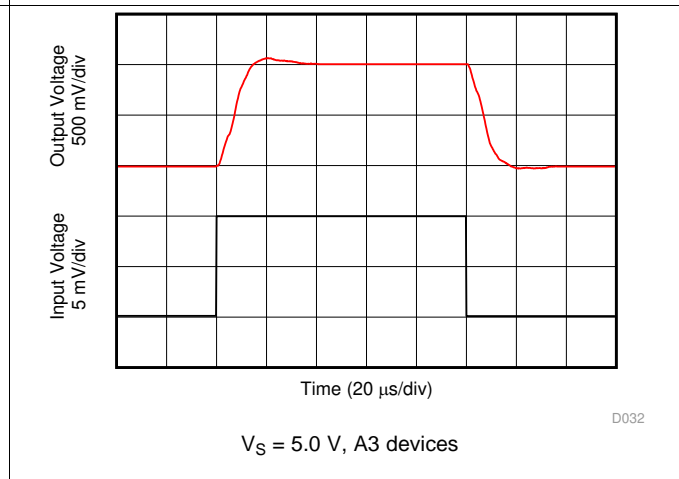

Figure 22. Step Response (10-mV_{PP} Input Step)

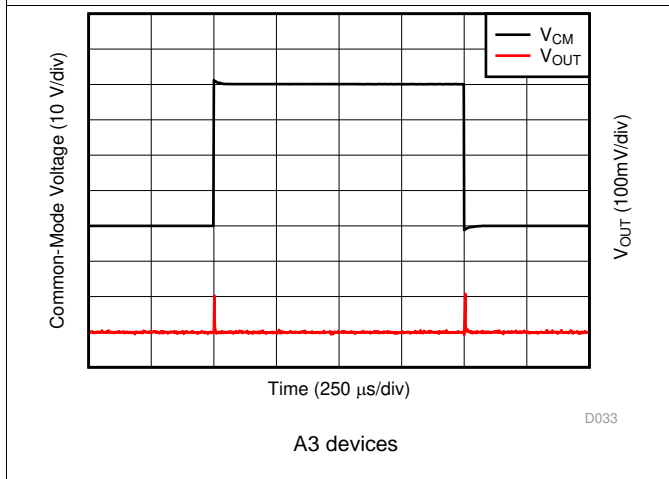

Figure 23. Common-Mode Voltage Transient Response

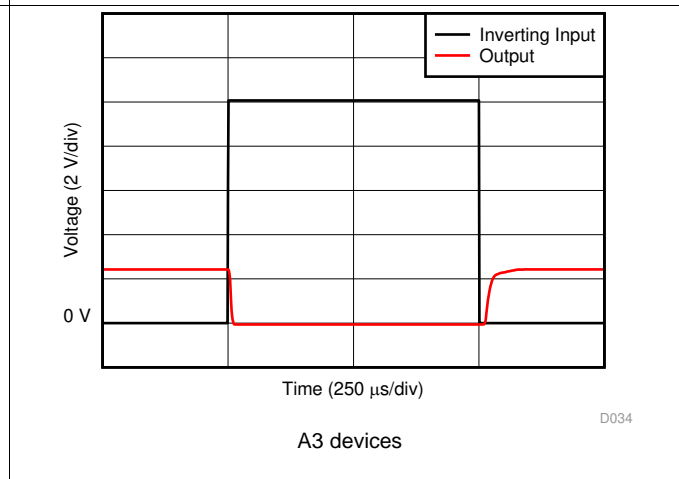

Figure 24. Inverting Differential Input Overload

Typical Characteristics (continued)

at $T_A = 25^\circ\text{C}$, $V_S = 1.8\text{ V}$, $V_{IN+} = 12\text{ V}$, $V_{REF} = V_S / 2$, $V_{ENABLE} = V_S$, and for all gain options (unless otherwise noted)

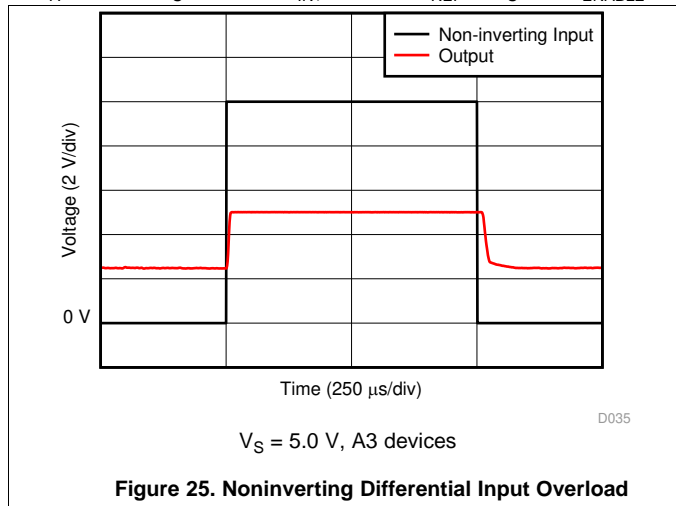

Figure 25. Noninverting Differential Input Overload

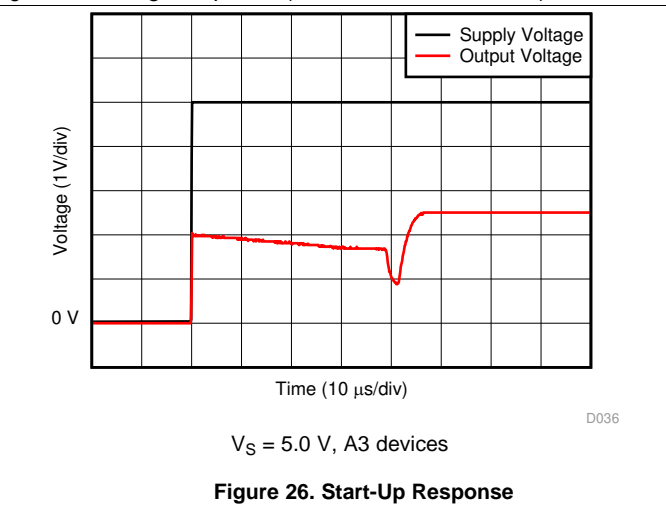

Figure 26. Start-Up Response

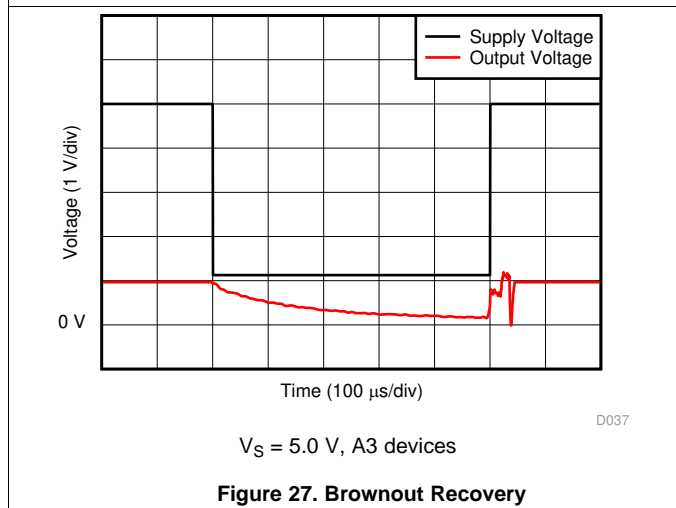

Figure 27. Brownout Recovery

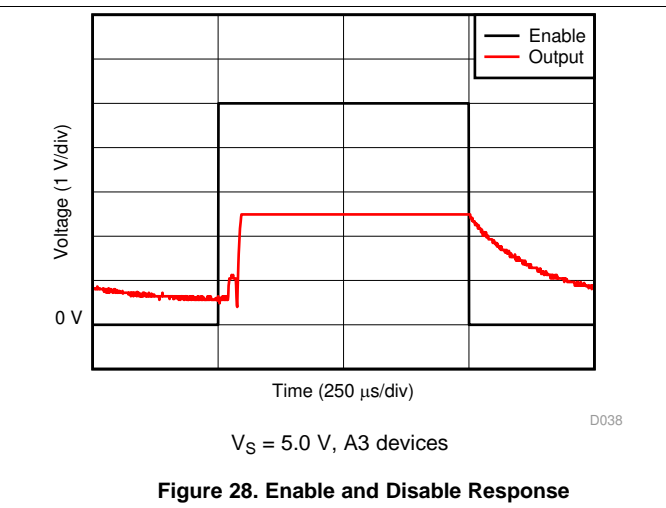

Figure 28. Enable and Disable Response

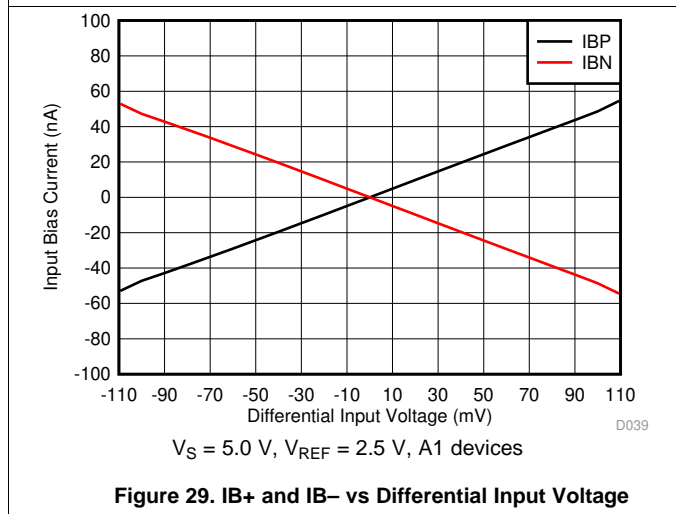

Figure 29. $IB+$ and $IB-$ vs Differential Input Voltage

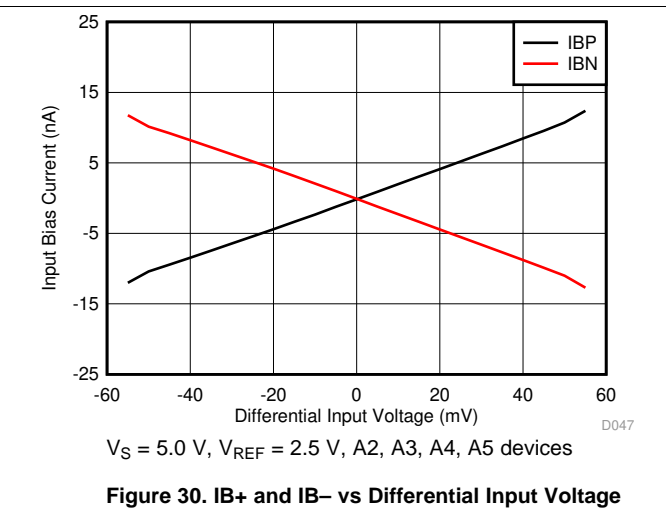
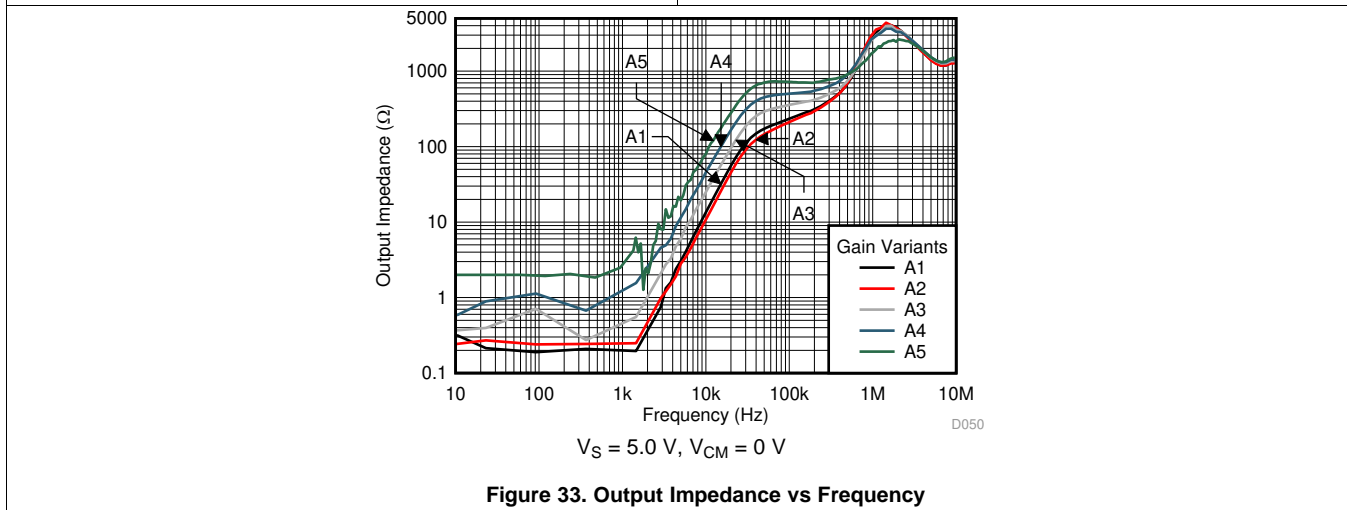
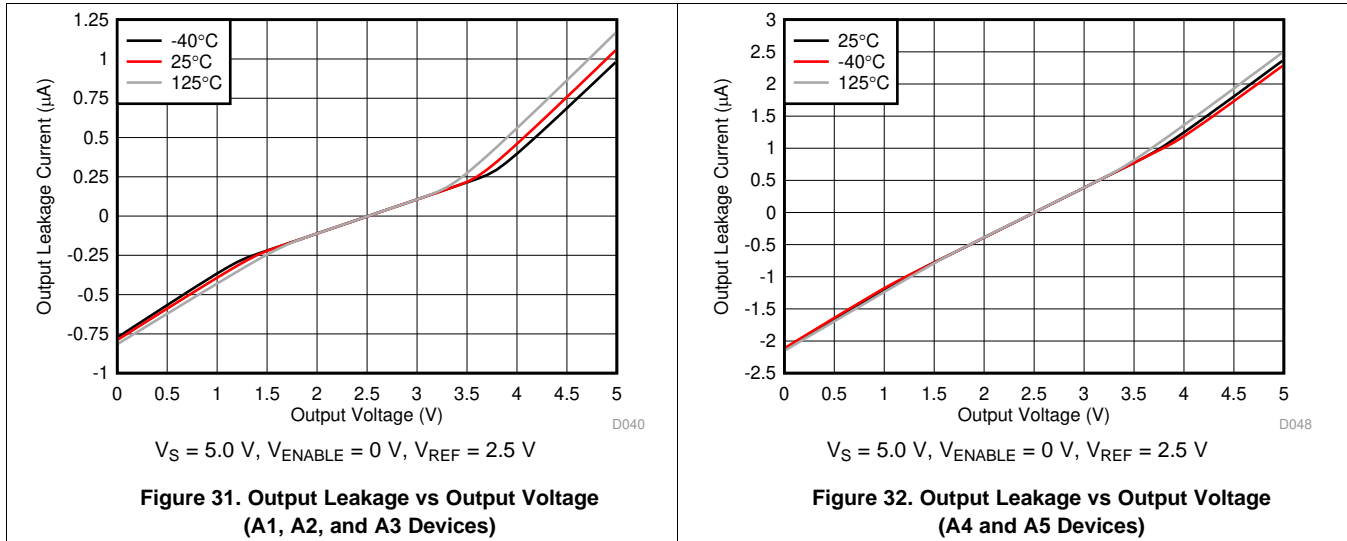

Figure 30. $IB+$ and $IB-$ vs Differential Input Voltage

Typical Characteristics (continued)

at $T_A = 25^\circ\text{C}$, $V_S = 1.8\text{ V}$, $V_{IN+} = 12\text{ V}$, $V_{REF} = V_S / 2$, $V_{ENABLE} = V_S$, and for all gain options (unless otherwise noted)



7 Detailed Description

7.1 Overview

The INA190 is a low bias current, low offset, 40-V common-mode, current-sensing amplifier. The DDF SOT-23 and RSW UQFN packages also feature an enable pin. The INA190 is a specially designed, current-sensing amplifier that accurately measures voltages developed across current-sensing resistors on common-mode voltages that far exceed the supply voltage. Current is measured on input voltage rails as high as 40 V at V_{IN+} and V_{IN-} , with a supply voltage, V_S , as low as 1.7 V. When disabled, the output goes to a high-impedance state, and the supply current draw is reduced to less than 0.1 μ A. The INA190 is intended for use in both low-side and high-side current-sensing configurations where high accuracy and low current consumption are required.

7.2 Functional Block Diagram

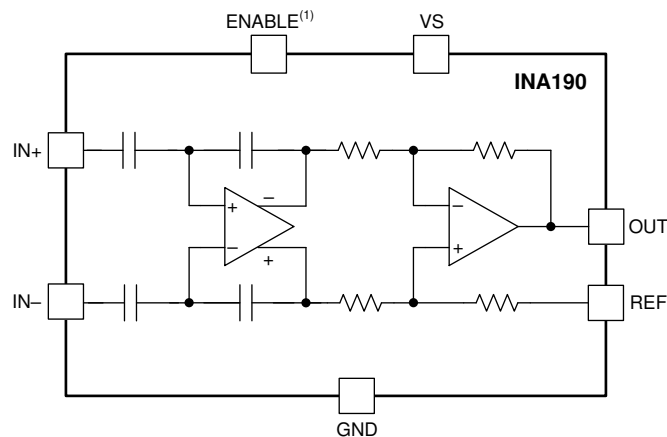

(1) The ENABLE pin is available only in the DDF and RSW packages.

7.3 Feature Description

7.3.1 Precision Current Measurement

The INA190 allows for accurate current measurements over a wide dynamic range. The high accuracy of the device is attributable to the low gain error and offset specifications. The offset voltage of the INA190 is less than 15 μV . In this case, the low offset improves the accuracy at light loads when $V_{\text{IN}+}$ approaches $V_{\text{IN}-}$. Another advantage of low offset is the ability to use a lower-value shunt resistor that reduces the power loss in the current-sense circuit, and improves the power efficiency of the end application.

The maximum gain error of the INA190 is specified between 0.2% and 0.4% of the actual value, depending on the gain option. As the sensed voltage becomes much larger than the offset voltage, the gain error becomes the dominant source of error in the current-sense measurement. When the device monitors currents near the full-scale output range, the total measurement error approaches the value of the gain error.

7.3.2 Low Input Bias Current

The INA190 is different from many current-sense amplifiers because this device offers very low input bias current. The low input bias current of the INA190 has three primary benefits.

The first benefit is the reduction of the current consumed by the device in both the enabled and disabled states. Classical current-sense amplifier topologies typically consume tens of microamps of current at the inputs. For these amplifiers, the input current is the result of the resistor network that sets the gain and additional current to bias the input amplifier. To reduce the bias current to near zero, the INA190 uses a capacitively coupled amplifier on the input stage, followed by a difference amplifier on the output stage.

The second benefit of low bias current is the ability to use input filters to reject high-frequency noise before the signal is amplified. In a traditional current-sense amplifier, the addition of input filters comes at the cost of reduced accuracy. However, as a result of the low bias currents, input filters have little effect on the measurement accuracy of the INA190.

The third benefit of low bias current is the ability to use a larger current-sense resistor. This ability allows the device to accurately monitor currents as low as 1 μA .

7.3.3 Low Quiescent Current With Output Enable

The device features low quiescent current (I_{Q}), while still providing sufficient small-signal bandwidth to be usable in most applications. The quiescent current of the INA190 is only 48 μA (typ), while providing a small-signal bandwidth of 35 kHz in a gain of 100. The low I_{Q} and good bandwidth allow the device to be used in many portable electronic systems without excessive drain on the battery. Because many applications only need to periodically monitor current, the INA190 features an enable pin that turns off the device until needed. When in the disabled state, the INA190 typically draws 10 nA of total supply current.

7.3.4 Bidirectional Current Monitoring

INA190 devices can sense current flow through a sense resistor in both directions. The bidirectional current-sensing capability is achieved by applying a voltage at the REF pin to offset the output voltage. A positive differential voltage sensed at the inputs results in an output voltage that is greater than the applied reference voltage. Likewise, a negative differential voltage at the inputs results in output voltage that is less than the applied reference voltage. The output voltage of the current-sense amplifier is shown in [Equation 1](#).

$$V_{\text{OUT}} = (I_{\text{LOAD}} \times R_{\text{SENSE}} \times \text{GAIN}) + V_{\text{REF}}$$

where

- I_{LOAD} is the load current to be monitored.
- R_{SENSE} is the current-sense resistor.
- GAIN is the gain option of the selected device.
- V_{REF} is the voltage applied to the REF pin.

(1)

Feature Description (continued)

7.3.5 High-Side and Low-Side Current Sensing

The INA190 supports input common-mode voltages from -0.2 V to $+40\text{ V}$. Because of the internal topology, the common-mode range is not restricted by the power-supply voltage (V_S). The ability to operate with common-mode voltages greater or less than V_S allows the INA190 to be used in high-side and low-side current-sensing applications, as shown in Figure 34.

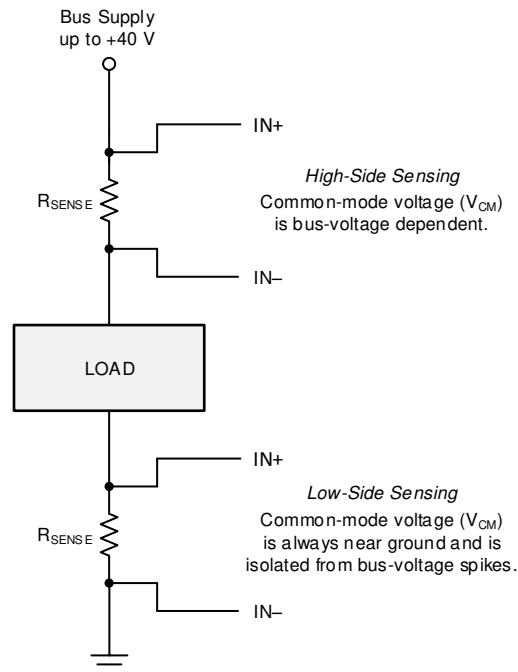

Figure 34. High-Side and Low-Side Sensing Connections

7.3.6 High Common-Mode Rejection

The INA190 uses a capacitively coupled amplifier on the front end. Therefore, dc common-mode voltages are blocked from downstream circuits, resulting in very high common-mode rejection. Typically, the common-mode rejection of the INA190 is approximately 150 dB. The ability to reject changes in the dc common-mode voltage allows the INA190 to monitor both high- and low-voltage rail currents with very little change in the offset voltage.

7.3.7 Rail-to-Rail Output Swing

The INA190 allows linear current-sensing operation with the output close to the supply rail and ground. The maximum specified output swing to the positive rail is $V_S - 40\text{ mV}$, and the maximum specified output swing to GND is only $\text{GND} + 1\text{ mV}$. The close-to-rail output swing is useful to maximize the usable output range, particularly when operating the device from a 1.8-V supply.

7.4 Device Functional Modes

7.4.1 Normal Operation

The INA190 is in normal operation when the following conditions are met:

- The power-supply voltage (V_S) is between 1.7 V and 5.5 V.
- The common-mode voltage (V_{CM}) is within the specified range of -0.2 V to $+40$ V.
- The maximum differential input signal times the gain plus V_{REF} is less than the positive swing voltage V_{SP} .
- The ENABLE pin is driven or connected to V_S .
- The minimum differential input signal times the gain plus V_{REF} is greater than the zero load swing to GND, V_{ZL} (see the [Rail-to-Rail Output Swing](#) section).

During normal operation, this device produces an output voltage that is the *amplified* representation of the difference voltage from IN+ to IN– plus the voltage applied to the REF pin.

7.4.2 Unidirectional Mode

This device can be configured to monitor current flowing in one direction (unidirectional) or in both directions (bidirectional) depending on how the REF pin is connected. The most common case is unidirectional where the output is set to ground when no current is flowing by connecting the REF pin to ground, as shown in [Figure 35](#). When the current flows from the bus supply to the load, the input voltage from IN+ to IN– increases and causes the output voltage at the OUT pin to increase.

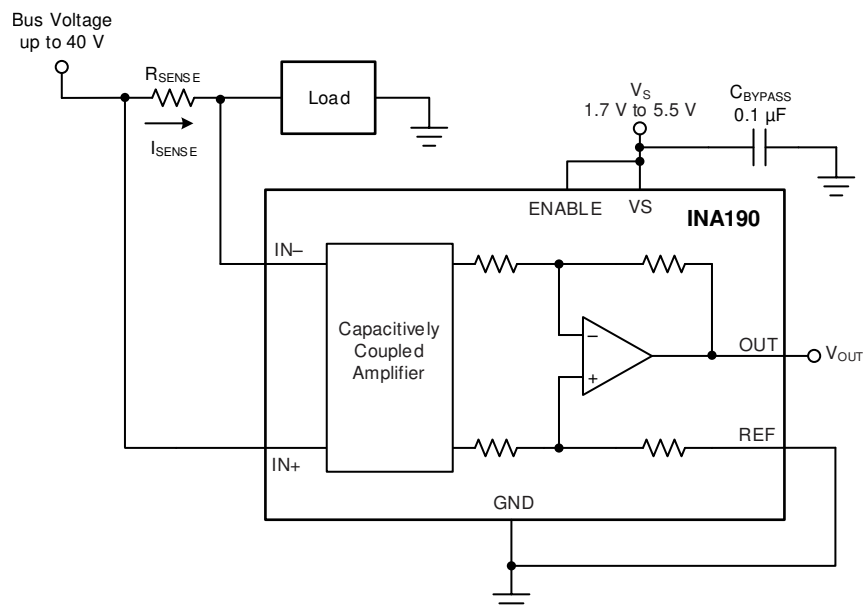

Figure 35. Typical Unidirectional Application

The linear range of the output stage is limited by how close the output voltage can approach ground under zero input conditions. The zero current output voltage of the INA190 is very small and for most unidirectional applications the REF pin is simply grounded. However, if the measured current multiplied by the current sense resistor and device gain is less than the zero current output voltage then bias the REF pin to a convenient value above the zero current output voltage to get the output into the linear range of the device. To limit common-mode rejection errors, buffer the reference voltage connected to the REF pin.

A less-frequently used output biasing method is to connect the REF pin to the power-supply voltage, V_S . This method results in the output voltage saturating at 40 mV less than the supply voltage when no differential input voltage is present. This method is similar to the output saturated low condition with no differential input voltage when the REF pin is connected to ground. The output voltage in this configuration only responds to currents that develop negative differential input voltage relative to the device IN– pin. Under these conditions, when the negative differential input signal increases, the output voltage moves downward from the saturated supply voltage. The voltage applied to the REF pin must not exceed V_S .

Device Functional Modes (continued)

Another use for the REF pin in unidirectional operation is to level shift the output voltage. Figure 36 shows an application where the device ground is set to a negative voltage so currents biased to negative supplies, as seen in optical networking cards, can be measured. The GND of the INA190 can be set to negative voltages, as long as the inputs do not violate the common-mode range specification and the voltage difference between VS and GND does not exceed 5.5 V. In this example, the output of the INA190 is fed into a positive-biased ADC. By grounding the REF pin, the voltages at the output will be positive and not damage the ADC. To make sure the output voltage never goes negative, the supply sequencing must be the positive supply first, followed by the negative supply.

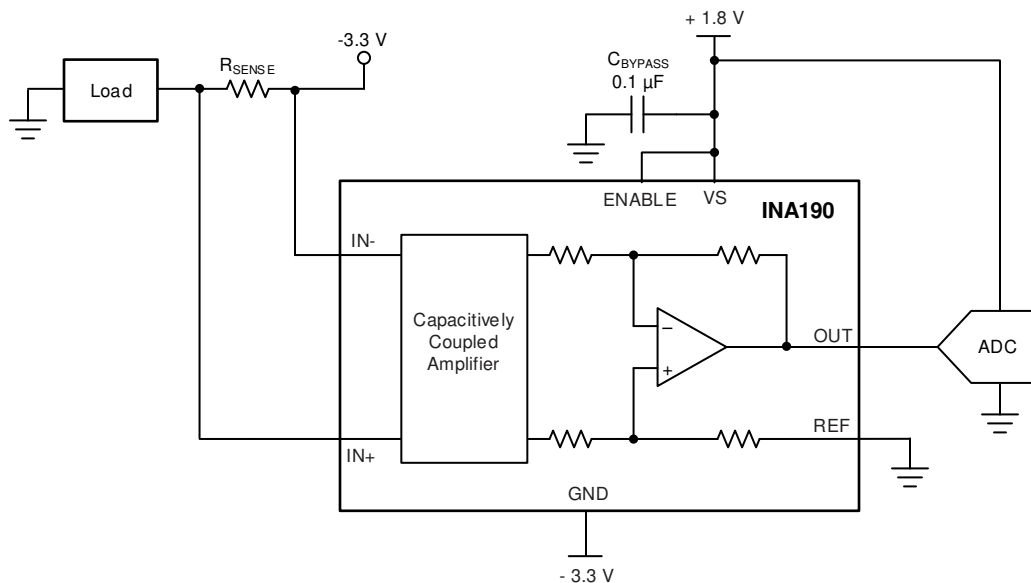

Figure 36. Using the REF Pin to Level-Shift Output Voltage

Device Functional Modes (continued)

7.4.3 Bidirectional Mode

The INA190 devices are bidirectional current-sense amplifiers capable of measuring currents through a resistive shunt in two directions. This bidirectional monitoring is common in applications that include charging and discharging operations where the current flowing through the resistor can change directions.

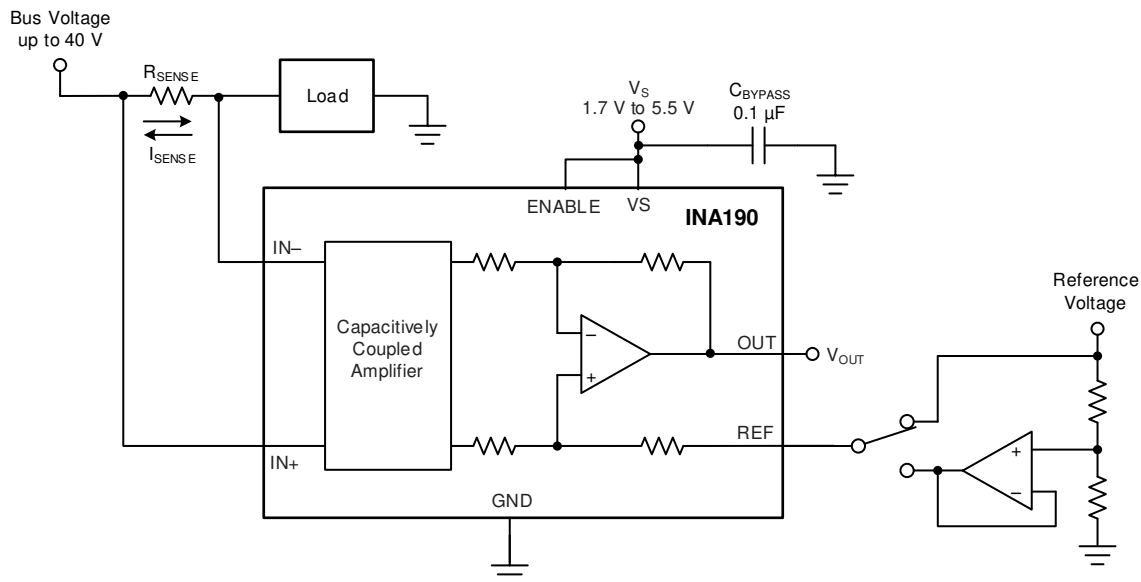

Figure 37. Bidirectional Application

The ability to measure this current flowing in both directions is achieved by applying a voltage to the REF pin, as shown in [Figure 37](#). The voltage applied to REF (V_{REF}) sets the output state that corresponds to the zero-input level state. The output then responds by increasing above V_{REF} for positive differential signals (relative to the IN- pin) and responds by decreasing below V_{REF} for negative differential signals. This reference voltage applied to the REF pin can be set anywhere between 0 V to V_S . For bidirectional applications, V_{REF} is typically set at $V_S/2$ for equal signal range in both current directions. In some cases, V_{REF} is set at a voltage other than $V_S/2$; for example, when the bidirectional current and corresponding output signal do not need to be symmetrical.

7.4.4 Input Differential Overload

If the differential input voltage ($V_{IN+} - V_{IN-}$) times gain exceeds the voltage swing specification, the INA190 drives its output as close as possible to the positive supply or ground, and does not provide accurate measurement of the differential input voltage. If this input overload occurs during normal circuit operation, then reduce the value of the shunt resistor or use a lower-gain version with the chosen sense resistor to avoid this mode of operation. If a differential overload occurs in a time-limited fault event, then the output of the INA190 returns to the expected value approximately 80 μ s after the fault condition is removed.

Device Functional Modes (continued)

7.4.5 Shutdown

The INA190 features an active-high ENABLE pin that shuts down the device when pulled to ground. When the device is shut down, the quiescent current is reduced to 10 nA (typ), and the output goes to a high-impedance state. In a battery-powered application, the low quiescent current extends the battery lifetime when the current measurement is not needed. When the ENABLE pin is driven to the supply voltage, the device turns back on. The typical output settling time when enabled is 130 μ s.

The output of the INA190 goes to a high-impedance state when disabled. Therefore, you can connect multiple outputs of the INA190 together to a single ADC or measurement device, as shown in Figure 38.

When connected in this way, enable only one INA190 at a time, and make sure all devices have the same supply voltage.

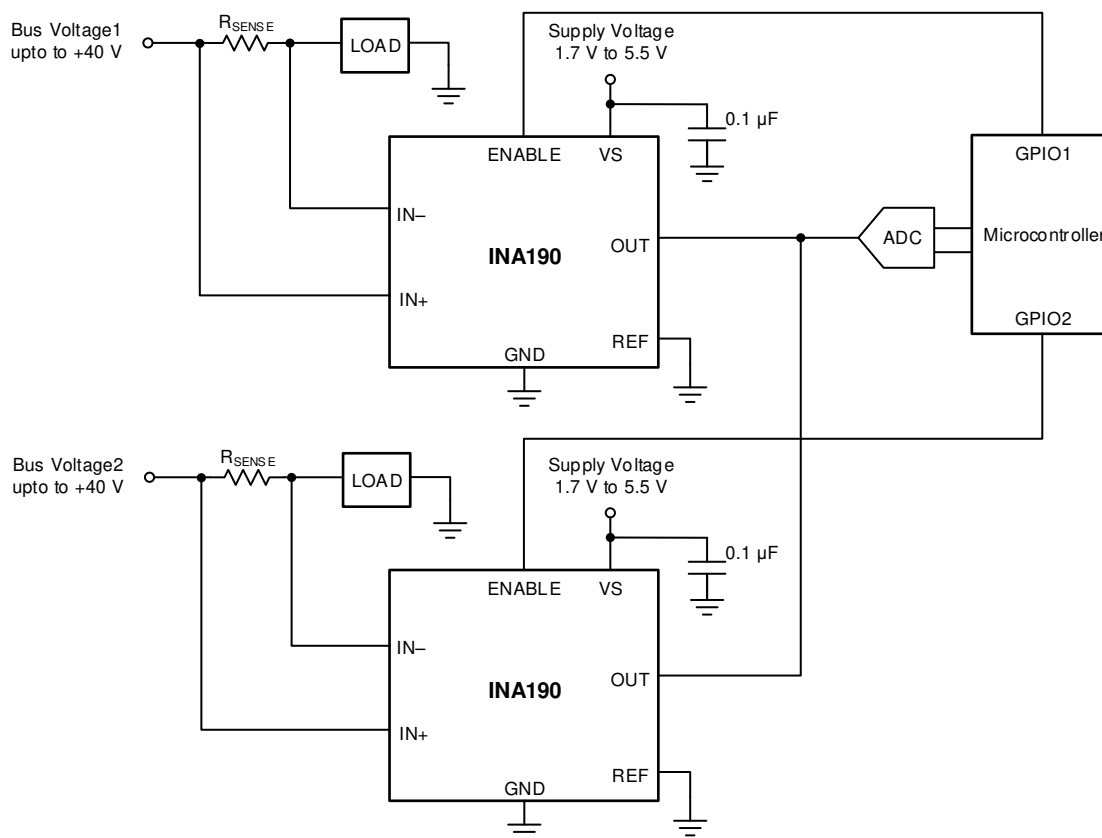

Figure 38. Multiplexing Multiple Devices With the ENABLE Pin

8 Application and Implementation

NOTE

Information in the following applications sections is not part of the TI component specification, and TI does not warrant its accuracy or completeness. TI's customers are responsible for determining suitability of components for their purposes. Customers should validate and test their design implementation to confirm system functionality.

8.1 Application Information

The INA190 amplifies the voltage developed across a current-sensing resistor as current flows through the resistor to the load or ground. The high common-mode rejection of the INA190 make it usable over a wide range of voltage rails while still maintaining an accurate current measurement.

8.1.1 Basic Connections

Figure 39 shows the basic connections of the INA190. Place the device as close as possible to the current sense resistor and connect the input pins (IN+ and IN-) to the current sense resistor through kelvin connections. If present, the ENABLE pin must be controlled externally or connected to VS if not used.

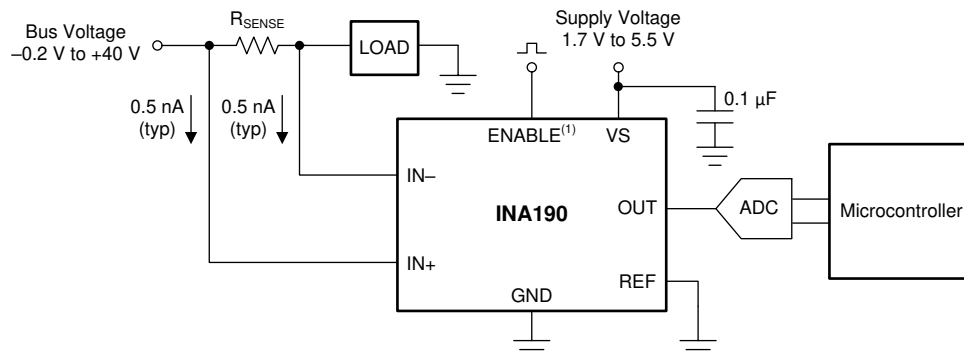

- (1) The ENABLE pin is available only in the DDF and RSW packages.

NOTE: To help eliminate ground offset errors between the device and the analog-to-digital converter (ADC), connect the REF pin to the ADC reference input. When driving SAR ADCs, filter or buffer the output of the INA190 before connecting directly to the ADC.

Figure 39. Basic Connections for the INA190

Application Information (continued)

8.1.2 R_{SENSE} and Device Gain Selection

The accuracy of any current-sense amplifier is maximized by choosing the current-sense resistor to be as large as possible. A large sense resistor maximizes the differential input signal for a given amount of current flow and reduces the error contribution of the offset voltage. However, there are practical limits as to how large the current-sense resistor can be in a given application because of the resistor size and maximum allowable power dissipation. [Equation 2](#) gives the maximum value for the current-sense resistor for a given power dissipation budget:

$$R_{\text{SENSE}} < \frac{PD_{\text{MAX}}}{I_{\text{MAX}}^2}$$

where:

- PD_{MAX} is the maximum allowable power dissipation in R_{SENSE}.
- I_{MAX} is the maximum current that will flow through R_{SENSE}. (2)

An additional limitation on the size of the current-sense resistor and device gain is due to the power-supply voltage, V_S, and device swing-to-rail limitations. In order to make sure that the current-sense signal is properly passed to the output, both positive and negative output swing limitations must be examined. [Equation 3](#) provides the maximum values of R_{SENSE} and GAIN to keep the device from exceeding the positive swing limitation.

$$I_{\text{MAX}} \times R_{\text{SENSE}} \times \text{GAIN} < V_{\text{SP}} - V_{\text{REF}}$$

where:

- I_{MAX} is the maximum current that will flow through R_{SENSE}.
- GAIN is the gain of the current-sense amplifier.
- V_{SP} is the positive output swing as specified in the data sheet.
- V_{REF} is the externally applied voltage on the REF pin. (3)

To avoid positive output swing limitations when selecting the value of R_{SENSE}, there is always a trade-off between the value of the sense resistor and the gain of the device under consideration. If the sense resistor selected for the maximum power dissipation is too large, then it is possible to select a lower-gain device in order to avoid positive swing limitations.

The negative swing limitation places a limit on how small the sense resistor value can be for a given application. [Equation 4](#) provides the limit on the minimum value of the sense resistor.

$$I_{\text{MIN}} \times R_{\text{SENSE}} \times \text{GAIN} > V_{\text{SN}} - V_{\text{REF}}$$

where:

- I_{MIN} is the minimum current that will flow through R_{SENSE}.
- GAIN is the gain of the current-sense amplifier.
- V_{SN} is the negative output swing of the device (see [Rail-to-Rail Output Swing](#)).
- V_{REF} is the externally applied voltage on the REF pin. (4)

In addition to adjusting R_{SENSE} and the device gain, the voltage applied to the REF pin can be slightly increased above GND to avoid negative swing limitations.

Application Information (continued)

8.1.3 Signal Conditioning

When performing accurate current measurements in noisy environments, the current-sensing signal is often filtered. The INA190 features low input bias currents. Therefore, adding a differential mode filter to the input without sacrificing the current-sense accuracy is possible. Filtering at the input is advantageous because this action attenuates differential noise before the signal is amplified. Figure 40 provides an example of how to use a filter on the input pins of the device.

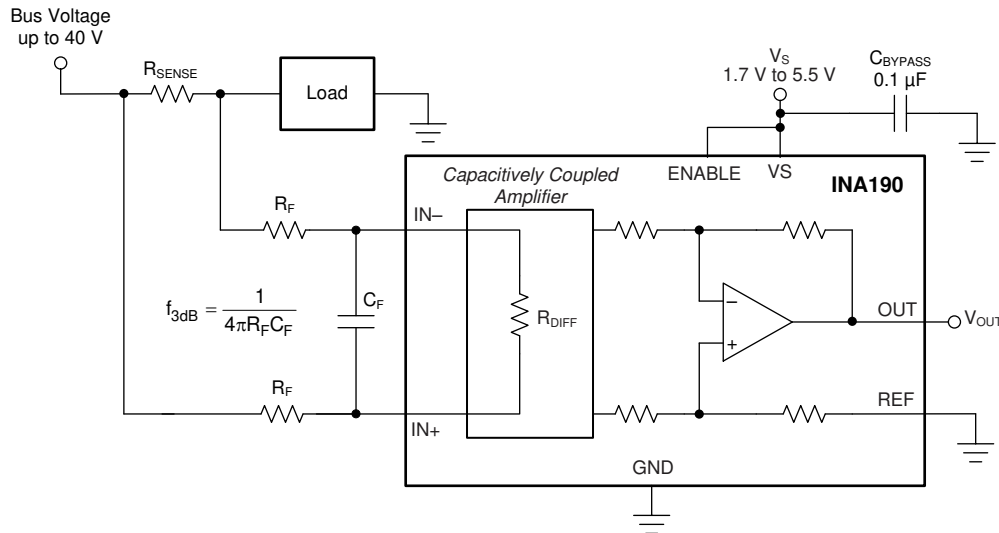

Figure 40. Filter at the Input Pins

The differential input impedance (R_{DIFF}) shown in Figure 40 limits the maximum value for R_F . The value of R_{DIFF} is a function of the device temperature, as shown in Figure 41.

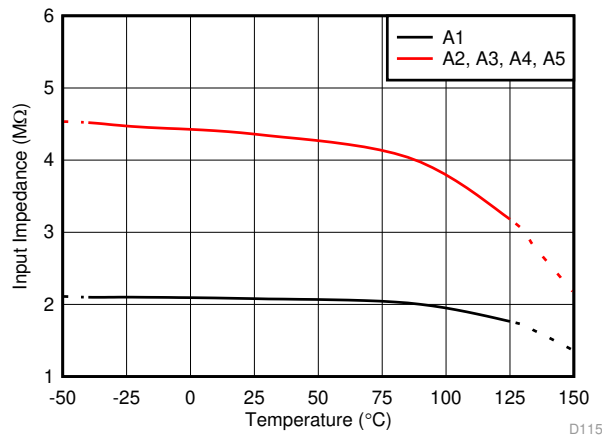

Figure 41. Differential Input Impedance vs Temperature

Application Information (continued)

As the voltage drop across the sense resistor (V_{SENSE}) increases, the amount of voltage dropped across the input filter resistors (R_F) also increases. The increased voltage drop results in additional gain error. The error caused by these resistors is calculated by the resistor divider equation shown in [Equation 5](#).

$$\text{Error}(\%) = \left(1 - \frac{R_{\text{DIFF}}}{R_{\text{SENSE}} + R_{\text{DIFF}} + (2 \times R_F)} \right) \times 100$$

where:

- R_{DIFF} is the differential input impedance.
- R_F is the added value of the series filter resistance. (5)

The input stage of the INA190 uses a capacitive feedback amplifier topology in order to achieve high dc precision. As a result, periodic high-frequency shunt voltage (or current) transients of significant amplitude (10 mV or greater) and duration (hundreds of nanoseconds or greater) may be amplified by the INA190, even though the transients are greater than the device bandwidth. Use a differential input filter in these applications to minimize disturbances at the INA190 output.

The high input impedance and low bias current of the INA190 provide flexibility in the input filter design without impacting the accuracy of current measurement. For example, set $R_F = 100 \, \Omega$ and $C_F = 22 \, \text{nF}$ to achieve a low-pass filter corner frequency of 36.2 kHz. These filter values significantly attenuate most unwanted high-frequency signals at the input without severely impacting the current sensing bandwidth or precision. If a lower corner frequency is desired, increase the value of C_F .

Filtering the input filters out differential noise across the sense resistor. If high-frequency, common-mode noise is a concern, add an RC filter from the OUT pin to ground. The RC filter helps filter out both differential and common mode noise, as well as, internally generated noise from the device. The value for the resistance of the RC filter is limited by the impedance of the load. Any current drawn by the load manifests as an external voltage drop from the INA190 OUT pin to the load input. To select the optimal values for the output filter, use [Figure 33](#) and see the [Closed-Loop Analysis of Load-Induced Amplifier Stability Issues Using ZOUT](#) application report

Application Information (continued)

8.1.4 Common-Mode Voltage Transients

With a small amount of additional circuitry, the INA190 can be used in circuits subject to transients that exceed the absolute maximum voltage ratings. The most simple way to protect the inputs from negative transients is to add resistors in series to the IN– and IN+ pins. Use resistors that are 1 kΩ or less, and limit the current in the ESD structures to less than 5 mA. For example, using 1-kΩ resistors in series with the INA190 allows voltages as low as –5 V, while limiting the ESD current to less than 5 mA. If protection from high-voltage or more-negative, common-voltage transients is needed, use the circuits shown in [Figure 42](#) and [Figure 43](#). When implementing these circuits, use only Zener diodes or Zener-type transient absorbers (sometimes referred to as *transzorb*s); any other type of transient absorber has an unacceptable time delay. Start by adding a pair of resistors as a working impedance for the Zener diode, as shown in [Figure 42](#). Keep these resistors as small as possible; most often, use around 100 Ω. Larger values can be used with an effect on gain that is discussed in the [Signal Conditioning](#) section. This circuit limits only short-term transients; therefore, many applications are satisfied with a 100-Ω resistor along with conventional Zener diodes of the lowest acceptable power rating. This combination uses the least amount of board space. These diodes can be found in packages as small as SOT-523 or SOD-523.

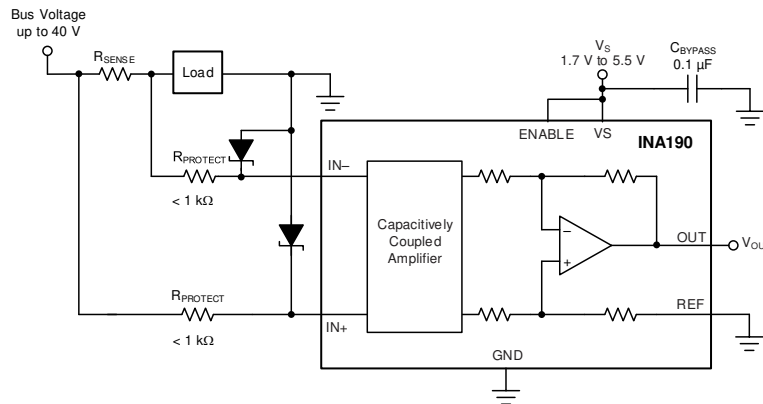

Figure 42. Transient Protection Using Dual Zener Diodes

In the event that low-power Zener diodes do not have sufficient transient absorption capability, a higher-power transzorb must be used. The most package-efficient solution involves using a single transzorb and back-to-back diodes between the device inputs, as shown in [Figure 43](#). The most space-efficient solutions are dual, series-connected diodes in a single SOT-523 or SOD-523 package. In either of the examples shown in [Figure 42](#) and [Figure 43](#), the total board area required by the INA190 with all protective components is less than that of an SO-8 package, and only slightly greater than that of an VSSOP-8 package.

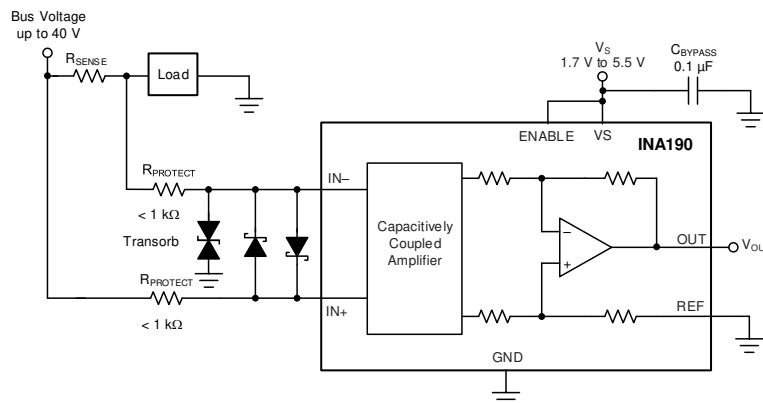

Figure 43. Transient Protection Using a Single Transzorb and Input Clamps

For more information, see the [Current Shunt Monitor With Transient Robustness](#) reference design.

8.2 Typical Applications

The low input bias current of the INA190 allows accurate monitoring of small-value currents. To accurately monitor currents in the microamp range, increase the value of the sense resistor to increase the sense voltage so that the error introduced by the offset voltage is small. The circuit configuration for monitoring low-value currents is shown in [Figure 44](#). As a result of the differential input impedance of the INA190, limit the value of R_{SENSE} to 1 k Ω or less for best accuracy.

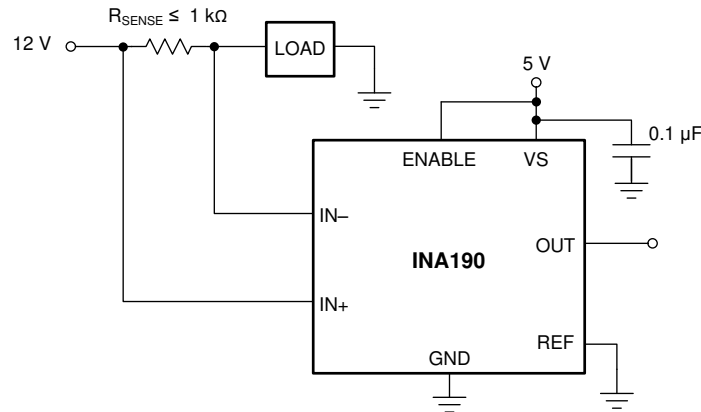

Figure 44. Microamp Current Measurement

8.2.1 Design Requirements

The design requirements for the circuit shown in [Figure 44](#) are listed in [Table 1](#).

Table 1. Design Parameters

DESIGN PARAMETER	EXAMPLE VALUE
Power-supply voltage (V_S)	5 V
Bus supply rail (V_{CM})	12 V
Minimum sense current (I_{MIN})	1 μ A
Maximum sense current (I_{MAX})	150 μ A
Device gain (GAIN)	25 V/V
Reference voltage (V_{REF})	0 V
Amplifier current in sleep or disabled state	< 1 μ A

8.2.2 Detailed Design Procedure

The maximum value of the current-sense resistor is calculated based choice of gain, value of the maximum current the be sensed (I_{MAX}), and the power supply voltage (V_S). When operating at the maximum current, the output voltage must not exceed the positive output swing specification, V_{SP} . Using Equation 6, for the given design parameters the maximum value for R_{SENSE} is calculated to be 1.321 k Ω .

$$R_{SENSE} < \frac{V_{SP}}{I_{MAX} \times GAIN} \quad (6)$$

However, because this value exceeds the maximum recommended value for R_{SENSE} , a resistance value of 1 k Ω must be used. When operating at the minimum current value, I_{MIN} the output voltage must be greater than the swing to GND (V_{SN}), specification. For this example, the output voltage at the minimum current is calculated using Equation 7 to be 25 mV, which is greater than the value for V_{SN} .

$$V_{OUTMIN} = I_{MIN} \times R_{SENSE} \times GAIN \quad (7)$$

8.2.3 Application Curve

Figure 45 shows the output of the device when disabled and enabled while measuring a 40- μ A load current. When disabled, the current draw from the device supply and inputs is less than 106 nA.

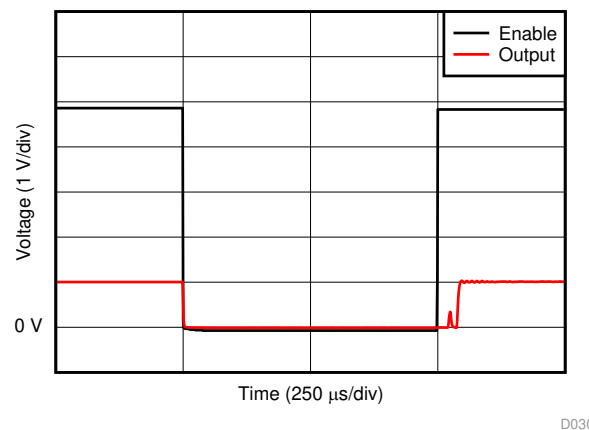

Figure 45. Output Disable and Enable Response

9 Power Supply Recommendations

The input circuitry of the INA190 accurately measures beyond the power-supply voltage, V_S . For example, V_S can be 5 V, whereas the bus supply voltage at $IN+$ and $IN-$ can be as high as 40 V. However, the output voltage range of the OUT pin is limited by the voltage on the VS pin. The INA190 also withstands the full differential input signal range up to 40 V at the $IN+$ and $IN-$ input pins, regardless of whether the device has power applied at the VS pin. There is no sequencing requirement for V_S and V_{IN+} or V_{IN-} .

10 Layout

10.1 Layout Guidelines

- Connect the input pins to the sensing resistor using a Kelvin or 4-wire connection. This connection technique makes sure that only the current-sensing resistor impedance is detected between the input pins. Poor routing of the current-sensing resistor commonly results in additional resistance present between the input pins. Given the very low ohmic value of the current resistor, any additional high-current carrying impedance can cause significant measurement errors.
- Place the power-supply bypass capacitor as close as possible to the device power supply and ground pins. The recommended value of this bypass capacitor is 0.1 μF . Additional decoupling capacitance can be added to compensate for noisy or high-impedance power supplies.
- When routing the connections from the current-sense resistor to the device, keep the trace lengths as short as possible. The input filter capacitor C_F should be placed as close as possible to the input pins of the device.

10.2 Layout Examples

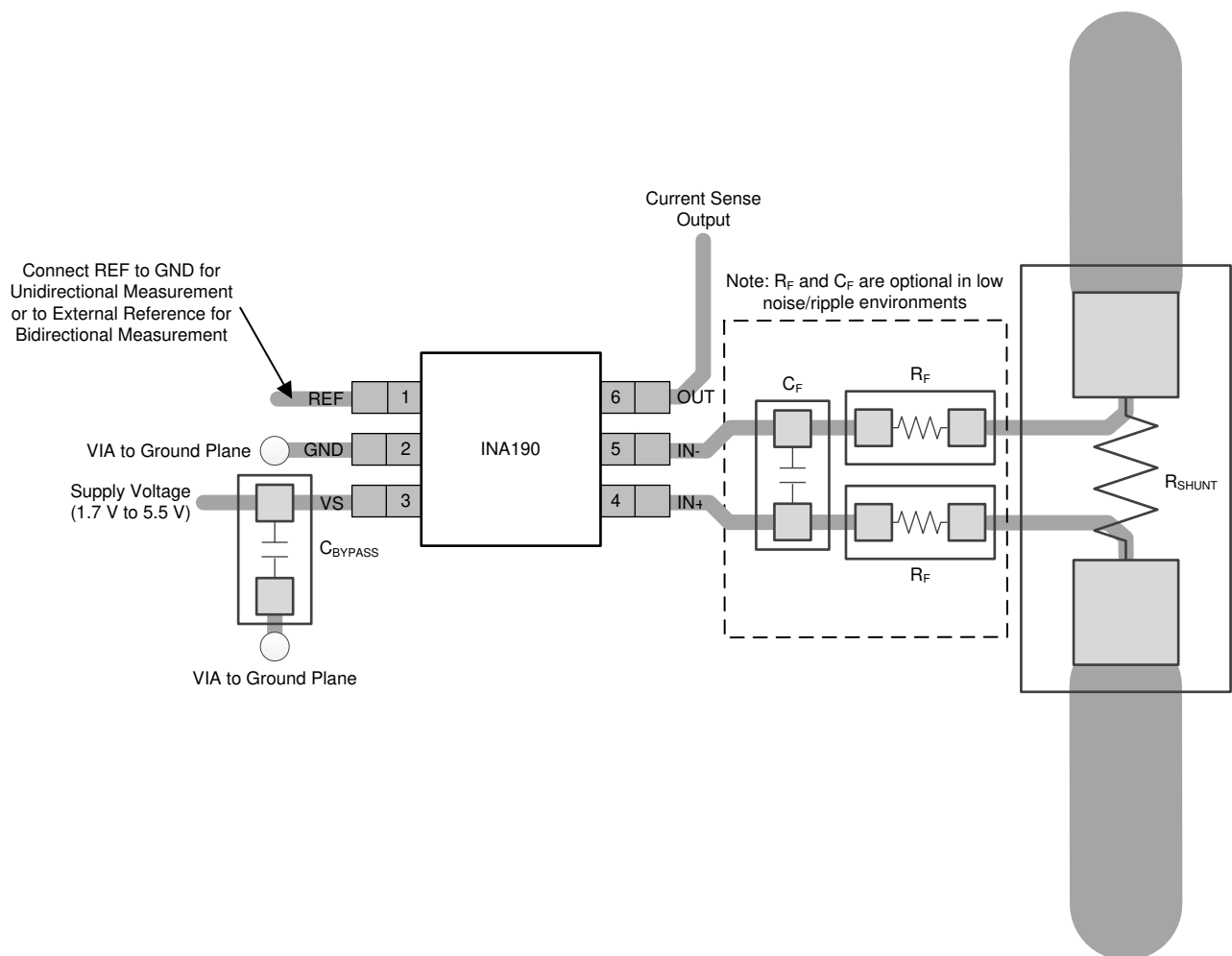

Figure 46. Recommended Layout for SC70 (DCK) Package

Layout Examples (continued)

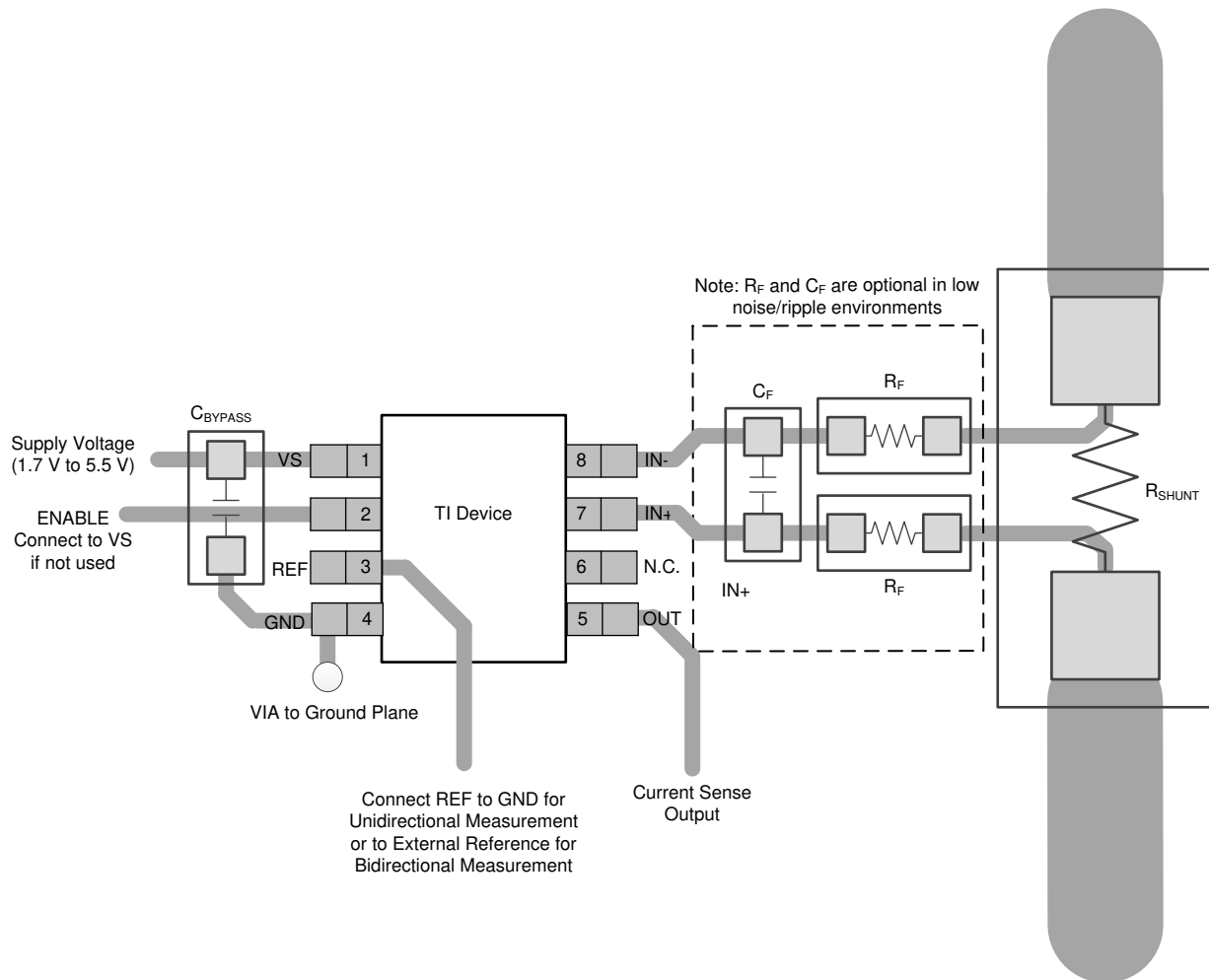

Figure 47. Recommended Layout for SOT23-8 (DDF) Package

Layout Examples (continued)

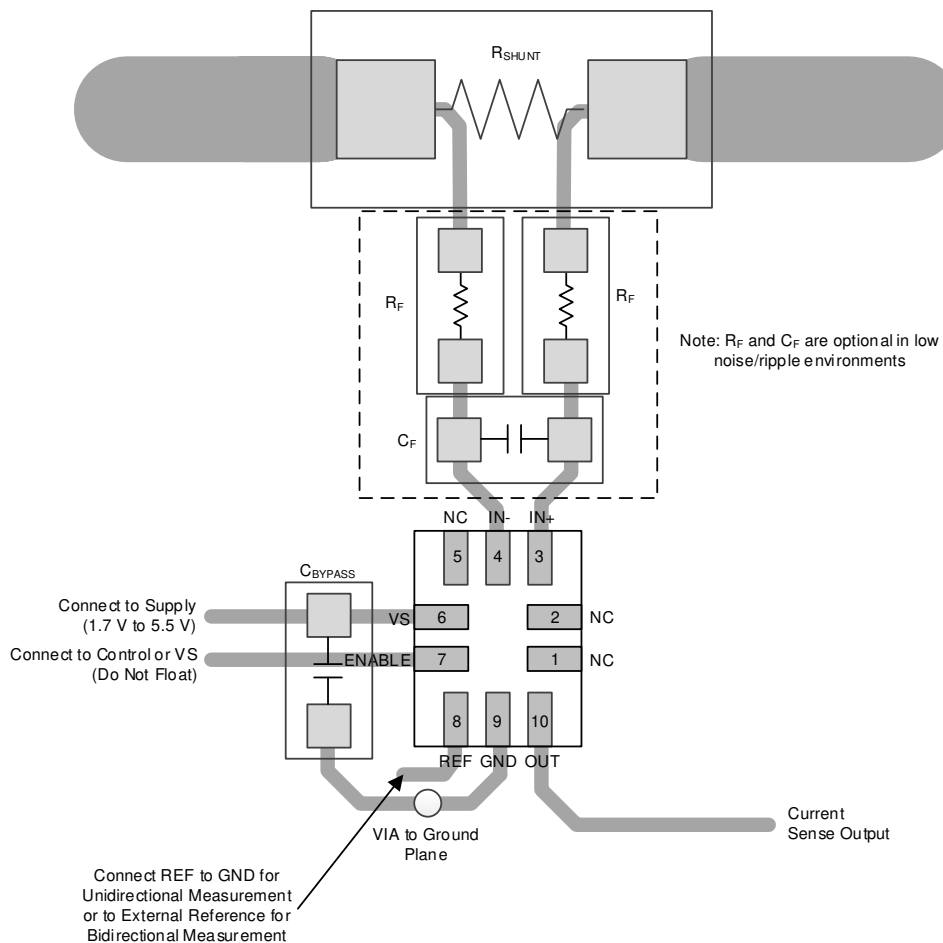

Figure 48. Recommended Layout for UQFN (RSW) Package

11 Device and Documentation Support

11.1 Documentation Support

11.1.1 Related Documentation

For related documentation see the following: Texas Instruments, [INA190EVM user's guide](#)

11.2 Receiving Notification of Documentation Updates

To receive notification of documentation updates, navigate to the device product folder on ti.com. In the upper right corner, click on *Alert me* to register and receive a weekly digest of any product information that has changed. For change details, review the revision history included in any revised document.

11.3 Support Resources

[TI E2E™ support forums](#) are an engineer's go-to source for fast, verified answers and design help — straight from the experts. Search existing answers or ask your own question to get the quick design help you need.

Linked content is provided "AS IS" by the respective contributors. They do not constitute TI specifications and do not necessarily reflect TI's views; see TI's [Terms of Use](#).

11.4 Trademarks

E2E is a trademark of Texas Instruments.
All other trademarks are the property of their respective owners.

11.5 Electrostatic Discharge Caution



This integrated circuit can be damaged by ESD. Texas Instruments recommends that all integrated circuits be handled with appropriate precautions. Failure to observe proper handling and installation procedures can cause damage.

ESD damage can range from subtle performance degradation to complete device failure. Precision integrated circuits may be more susceptible to damage because very small parametric changes could cause the device not to meet its published specifications.

11.6 Glossary

[SLYZ022](#) — *TI Glossary*.

This glossary lists and explains terms, acronyms, and definitions.

12 Mechanical, Packaging, and Orderable Information

The following pages include mechanical, packaging, and orderable information. This information is the most current data available for the designated devices. This data is subject to change without notice and revision of this document. For browser-based versions of this data sheet, refer to the left-hand navigation.

PACKAGING INFORMATION

Orderable Device	Status (1)	Package Type	Package Drawing	Pins	Package Qty	Eco Plan (2)	Lead finish/ Ball material (6)	MSL Peak Temp (3)	Op Temp (°C)	Device Marking (4/5)	Samples
INA190A1IDCKR	ACTIVE	SC70	DCK	6	3000	RoHS & Green	NIPDAU SN	Level-2-260C-1 YEAR	-40 to 125	1DP	Samples
INA190A1IDCKT	ACTIVE	SC70	DCK	6	250	RoHS & Green	NIPDAU SN	Level-2-260C-1 YEAR	-40 to 125	1DP	Samples
INA190A1IDDFR	ACTIVE	SOT-23-THIN	DDF	8	3000	RoHS & Green	NIPDAU	Level-1-260C-UNLIM	-40 to 125	1ZGW	Samples
INA190A1IDDFT	OBSOLETE	SOT-23-THIN	DDF	8		TBD	Call TI	Call TI	-40 to 125	1ZGW	
INA190A1IRSWR	ACTIVE	UQFN	RSW	10	3000	RoHS & Green	NIPDAU	Level-1-260C-UNLIM	-40 to 125	1AN	Samples
INA190A1IRSWT	ACTIVE	UQFN	RSW	10	250	RoHS & Green	NIPDAU	Level-1-260C-UNLIM	-40 to 125	1AN	Samples
INA190A2IDCKR	ACTIVE	SC70	DCK	6	3000	RoHS & Green	NIPDAU SN	Level-2-260C-1 YEAR	-40 to 125	1DQ	Samples
INA190A2IDCKT	ACTIVE	SC70	DCK	6	250	RoHS & Green	NIPDAU SN	Level-2-260C-1 YEAR	-40 to 125	1DQ	Samples
INA190A2IDDFR	ACTIVE	SOT-23-THIN	DDF	8	3000	RoHS & Green	NIPDAU	Level-1-260C-UNLIM	-40 to 125	1ZHW	Samples
INA190A2IDDFT	OBSOLETE	SOT-23-THIN	DDF	8		TBD	Call TI	Call TI	-40 to 125	1ZHW	
INA190A2IRSWR	ACTIVE	UQFN	RSW	10	3000	RoHS & Green	NIPDAU	Level-1-260C-UNLIM	-40 to 125	1AM	Samples
INA190A2IRSWT	ACTIVE	UQFN	RSW	10	250	RoHS & Green	NIPDAU	Level-1-260C-UNLIM	-40 to 125	1AM	Samples
INA190A3IDCKR	ACTIVE	SC70	DCK	6	3000	RoHS & Green	NIPDAU SN	Level-2-260C-1 YEAR	-40 to 125	1DR	Samples
INA190A3IDCKT	OBSOLETE	SC70	DCK	6		TBD	Call TI	Call TI	-40 to 125	1DR	
INA190A3IDDFR	ACTIVE	SOT-23-THIN	DDF	8	3000	RoHS & Green	NIPDAU	Level-1-260C-UNLIM	-40 to 125	1ZIW	Samples
INA190A3IDDFT	OBSOLETE	SOT-23-THIN	DDF	8		TBD	Call TI	Call TI	-40 to 125	1ZIW	
INA190A3IRSWR	ACTIVE	UQFN	RSW	10	3000	RoHS & Green	NIPDAU	Level-1-260C-UNLIM	-40 to 125	1AO	Samples
INA190A3IRSWT	ACTIVE	UQFN	RSW	10	250	RoHS & Green	NIPDAU	Level-1-260C-UNLIM	-40 to 125	1AO	Samples
INA190A4IDCKR	ACTIVE	SC70	DCK	6	3000	RoHS & Green	NIPDAU SN	Level-2-260C-1 YEAR	-40 to 125	1DS	Samples
INA190A4IDCKT	OBSOLETE	SC70	DCK	6		TBD	Call TI	Call TI	-40 to 125	1DS	
INA190A4IDDFR	ACTIVE	SOT-23-THIN	DDF	8	3000	RoHS & Green	NIPDAU	Level-1-260C-UNLIM	-40 to 125	1ZJW	Samples

Orderable Device	Status (1)	Package Type	Package Drawing	Pins	Package Qty	Eco Plan (2)	Lead finish/ Ball material (6)	MSL Peak Temp (3)	Op Temp (°C)	Device Marking (4/5)	Samples
INA190A4IRSWR	ACTIVE	UQFN	RSW	10	3000	RoHS & Green	NIPDAU	Level-1-260C-UNLIM	-40 to 125	1AP	Samples
INA190A4IRSWT	ACTIVE	UQFN	RSW	10	250	RoHS & Green	NIPDAU	Level-1-260C-UNLIM	-40 to 125	1AP	Samples
INA190A5IDCKR	ACTIVE	SC70	DCK	6	3000	RoHS & Green	NIPDAU SN	Level-2-260C-1 YEAR	-40 to 125	1DT	Samples
INA190A5IDCKT	OBSOLETE	SC70	DCK	6		TBD	Call TI	Call TI	-40 to 125	1DT	
INA190A5IDDFR	ACTIVE	SOT-23-THIN	DDF	8	3000	RoHS & Green	NIPDAU	Level-1-260C-UNLIM	-40 to 125	1ZKW	Samples
INA190A5IDDFT	OBSOLETE	SOT-23-THIN	DDF	8		TBD	Call TI	Call TI	-40 to 125	1ZKW	
INA190A5IRSWR	ACTIVE	UQFN	RSW	10	3000	RoHS & Green	NIPDAU	Level-1-260C-UNLIM	-40 to 125	1AQ	Samples
INA190A5IRSWT	OBSOLETE	UQFN	RSW	10		TBD	Call TI	Call TI	-40 to 125	1AQ	

(1) The marketing status values are defined as follows:

ACTIVE: Product device recommended for new designs.

LIFEBUY: TI has announced that the device will be discontinued, and a lifetime-buy period is in effect.

NRND: Not recommended for new designs. Device is in production to support existing customers, but TI does not recommend using this part in a new design.

PREVIEW: Device has been announced but is not in production. Samples may or may not be available.

OBSOLETE: TI has discontinued the production of the device.

(2) **RoHS:** TI defines "RoHS" to mean semiconductor products that are compliant with the current EU RoHS requirements for all 10 RoHS substances, including the requirement that RoHS substance do not exceed 0.1% by weight in homogeneous materials. Where designed to be soldered at high temperatures, "RoHS" products are suitable for use in specified lead-free processes. TI may reference these types of products as "Pb-Free".

RoHS Exempt: TI defines "RoHS Exempt" to mean products that contain lead but are compliant with EU RoHS pursuant to a specific EU RoHS exemption.

Green: TI defines "Green" to mean the content of Chlorine (Cl) and Bromine (Br) based flame retardants meet JS709B low halogen requirements of <=1000ppm threshold. Antimony trioxide based flame retardants must also meet the <=1000ppm threshold requirement.

(3) MSL, Peak Temp. - The Moisture Sensitivity Level rating according to the JEDEC industry standard classifications, and peak solder temperature.

(4) There may be additional marking, which relates to the logo, the lot trace code information, or the environmental category on the device.

(5) Multiple Device Markings will be inside parentheses. Only one Device Marking contained in parentheses and separated by a "~" will appear on a device. If a line is indented then it is a continuation of the previous line and the two combined represent the entire Device Marking for that device.

(6) Lead finish/Ball material - Orderable Devices may have multiple material finish options. Finish options are separated by a vertical ruled line. Lead finish/Ball material values may wrap to two lines if the finish value exceeds the maximum column width.

Important Information and Disclaimer: The information provided on this page represents TI's knowledge and belief as of the date that it is provided. TI bases its knowledge and belief on information provided by third parties, and makes no representation or warranty as to the accuracy of such information. Efforts are underway to better integrate information from third parties. TI has taken and continues to take reasonable steps to provide representative and accurate information but may not have conducted destructive testing or chemical analysis on incoming materials and chemicals. TI and TI suppliers consider certain information to be proprietary, and thus CAS numbers and other limited information may not be available for release.

In no event shall TI's liability arising out of such information exceed the total purchase price of the TI part(s) at issue in this document sold by TI to Customer on an annual basis.

OTHER QUALIFIED VERSIONS OF INA190 :

- Automotive : [INA190-Q1](#)
- Enhanced Product : [INA190-EP](#)

NOTE: Qualified Version Definitions:

- Automotive - Q100 devices qualified for high-reliability automotive applications targeting zero defects
- Enhanced Product - Supports Defense, Aerospace and Medical Applications

TAPE AND REEL INFORMATION

QUADRANT ASSIGNMENTS FOR PIN 1 ORIENTATION IN TAPE

*All dimensions are nominal

Device	Package Type	Package Drawing	Pins	SPQ	Reel Diameter (mm)	Reel Width W1 (mm)	A0 (mm)	B0 (mm)	K0 (mm)	P1 (mm)	W (mm)	Pin1 Quadrant
INA190A1IDCKR	SC70	DCK	6	3000	178.0	9.0	2.4	2.5	1.2	4.0	8.0	Q3
INA190A1IDCKT	SC70	DCK	6	250	178.0	9.0	2.4	2.5	1.2	4.0	8.0	Q3
INA190A1IDDFR	SOT-23-THIN	DDF	8	3000	180.0	8.4	3.2	3.2	1.4	4.0	8.0	Q3
INA190A1IRSWR	UQFN	RSW	10	3000	180.0	8.4	1.7	2.1	0.7	4.0	8.0	Q1
INA190A1IRSWT	UQFN	RSW	10	250	180.0	8.4	1.7	2.1	0.7	4.0	8.0	Q1
INA190A2IDCKR	SC70	DCK	6	3000	178.0	9.0	2.4	2.5	1.2	4.0	8.0	Q3
INA190A2IDCKT	SC70	DCK	6	250	178.0	9.0	2.4	2.5	1.2	4.0	8.0	Q3
INA190A2IDDFR	SOT-23-THIN	DDF	8	3000	180.0	8.4	3.2	3.2	1.4	4.0	8.0	Q3
INA190A2IRSWR	UQFN	RSW	10	3000	180.0	9.5	1.6	2.0	0.8	4.0	8.0	Q1
INA190A2IRSWT	UQFN	RSW	10	250	180.0	8.4	1.7	2.1	0.7	4.0	8.0	Q1
INA190A3IDCKR	SC70	DCK	6	3000	178.0	9.0	2.4	2.5	1.2	4.0	8.0	Q3
INA190A3IDDFR	SOT-23-THIN	DDF	8	3000	180.0	8.4	3.2	3.2	1.4	4.0	8.0	Q3
INA190A3IRSWR	UQFN	RSW	10	3000	180.0	9.5	1.6	2.0	0.8	4.0	8.0	Q1
INA190A3IRSWT	UQFN	RSW	10	250	180.0	8.4	1.7	2.1	0.7	4.0	8.0	Q1

Device	Package Type	Package Drawing	Pins	SPQ	Reel Diameter (mm)	Reel Width W1 (mm)	A0 (mm)	B0 (mm)	K0 (mm)	P1 (mm)	W (mm)	Pin1 Quadrant
INA190A4IDCKR	SC70	DCK	6	3000	178.0	9.0	2.4	2.5	1.2	4.0	8.0	Q3
INA190A4IDDFR	SOT-23-THIN	DDF	8	3000	180.0	8.4	3.2	3.2	1.4	4.0	8.0	Q3
INA190A4IRSWR	UQFN	RSW	10	3000	180.0	9.5	1.6	2.0	0.8	4.0	8.0	Q1
INA190A4IRSWT	UQFN	RSW	10	250	180.0	8.4	1.7	2.1	0.7	4.0	8.0	Q1
INA190A5IDCKR	SC70	DCK	6	3000	178.0	9.0	2.4	2.5	1.2	4.0	8.0	Q3
INA190A5IDDFR	SOT-23-THIN	DDF	8	3000	180.0	8.4	3.2	3.2	1.4	4.0	8.0	Q3
INA190A5IRSWR	UQFN	RSW	10	3000	180.0	9.5	1.6	2.0	0.8	4.0	8.0	Q1

TAPE AND REEL BOX DIMENSIONS



*All dimensions are nominal

Device	Package Type	Package Drawing	Pins	SPQ	Length (mm)	Width (mm)	Height (mm)
INA190A1IDCKR	SC70	DCK	6	3000	180.0	180.0	18.0
INA190A1IDCKT	SC70	DCK	6	250	180.0	180.0	18.0
INA190A1IDDFR	SOT-23-THIN	DDF	8	3000	210.0	185.0	35.0
INA190A1IRSWR	UQFN	RSW	10	3000	210.0	185.0	35.0
INA190A1IRSWT	UQFN	RSW	10	250	210.0	185.0	35.0
INA190A2IDCKR	SC70	DCK	6	3000	180.0	180.0	18.0
INA190A2IDCKT	SC70	DCK	6	250	180.0	180.0	18.0
INA190A2IDDFR	SOT-23-THIN	DDF	8	3000	210.0	185.0	35.0
INA190A2IRSWR	UQFN	RSW	10	3000	189.0	185.0	36.0
INA190A2IRSWT	UQFN	RSW	10	250	210.0	185.0	35.0
INA190A3IDCKR	SC70	DCK	6	3000	180.0	180.0	18.0
INA190A3IDDFR	SOT-23-THIN	DDF	8	3000	210.0	185.0	35.0
INA190A3IRSWR	UQFN	RSW	10	3000	189.0	185.0	36.0
INA190A3IRSWT	UQFN	RSW	10	250	210.0	185.0	35.0
INA190A4IDCKR	SC70	DCK	6	3000	180.0	180.0	18.0
INA190A4IDDFR	SOT-23-THIN	DDF	8	3000	210.0	185.0	35.0
INA190A4IRSWR	UQFN	RSW	10	3000	189.0	185.0	36.0
INA190A4IRSWT	UQFN	RSW	10	250	210.0	185.0	35.0

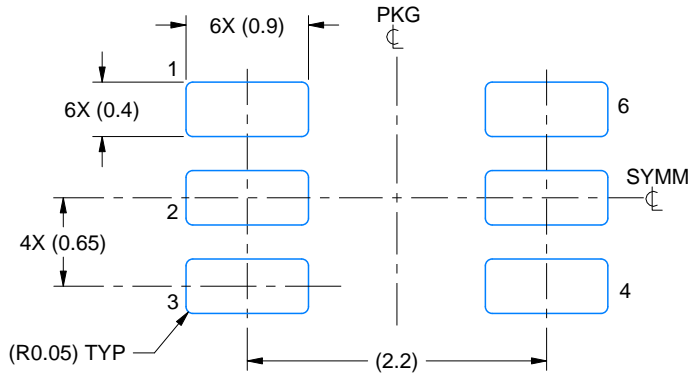
Device	Package Type	Package Drawing	Pins	SPQ	Length (mm)	Width (mm)	Height (mm)
INA190A5IDCKR	SC70	DCK	6	3000	180.0	180.0	18.0
INA190A5IDDFR	SOT-23-THIN	DDF	8	3000	210.0	185.0	35.0
INA190A5IRSWR	UQFN	RSW	10	3000	189.0	185.0	36.0

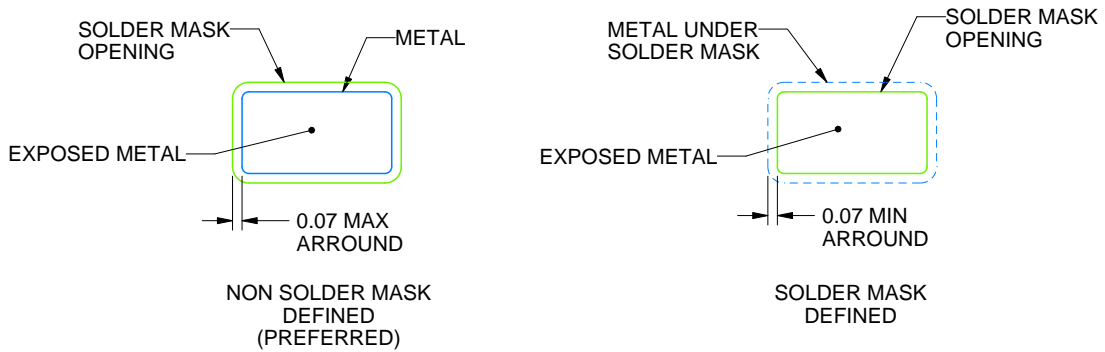

LAND PATTERN EXAMPLE
EXPOSED METAL SHOWN
SCALE:18X



SOLDER MASK DETAILS

4214835/C 08/2024

NOTES: (continued)

- 5. Publication IPC-7351 may have alternate designs.
- 6. Solder mask tolerances between and around signal pads can vary based on board fabrication site.

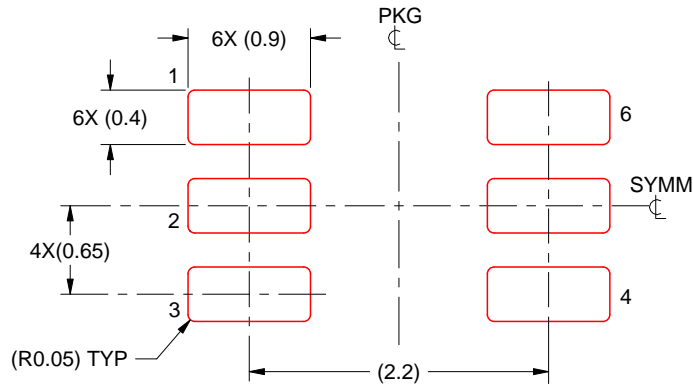

SOLDER PASTE EXAMPLE
BASED ON 0.125 THICK STENCIL
SCALE:18X

4214835/C 08/2024

NOTES: (continued)

7. Laser cutting apertures with trapezoidal walls and rounded corners may offer better paste release. IPC-7525 may have alternate design recommendations.
8. Board assembly site may have different recommendations for stencil design.

RSW0010A

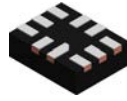

PACKAGE OUTLINE

UQFN - 0.55 mm max height

PLASTIC QUAD FLATPACK - NO LEAD

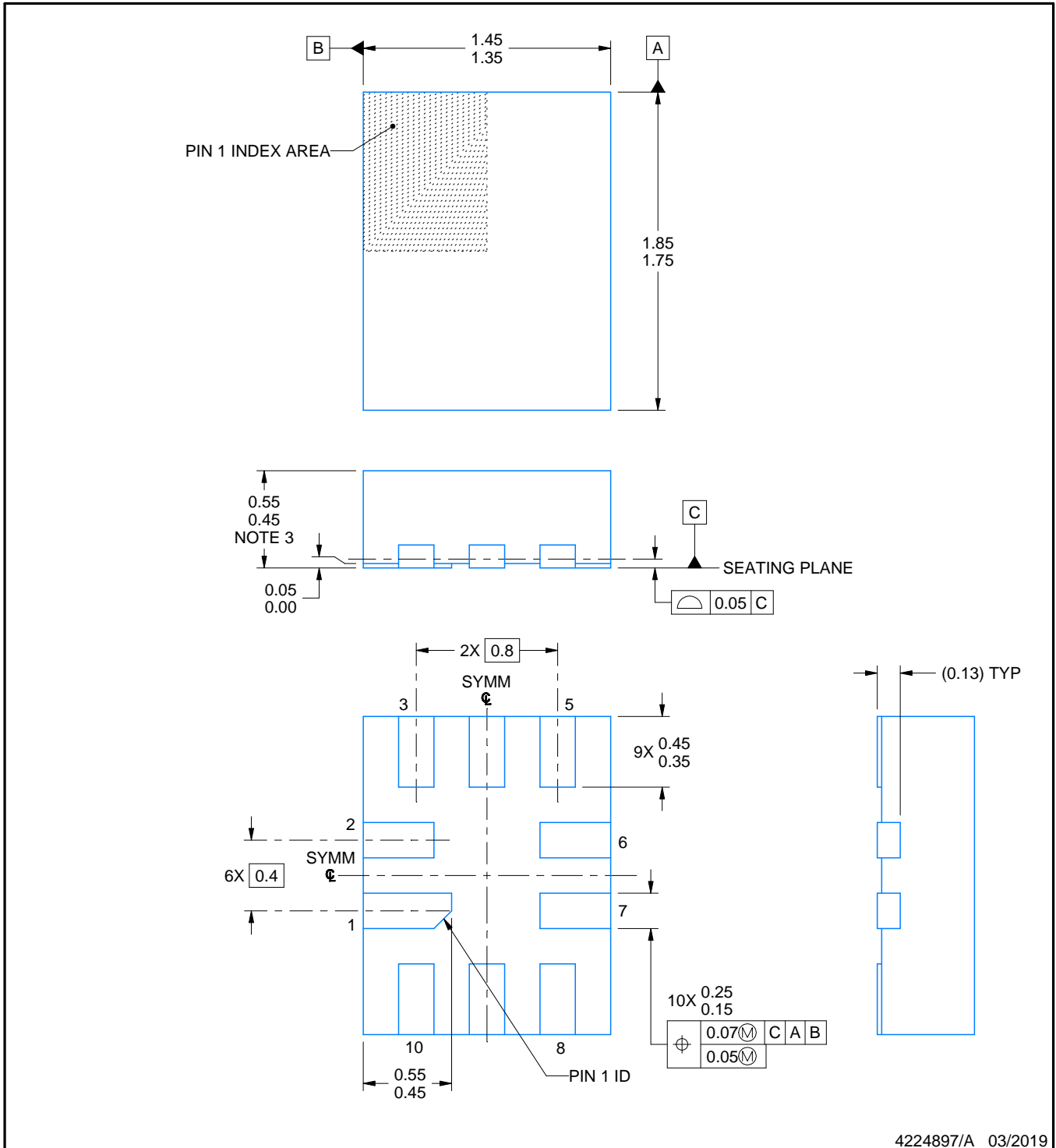

4224897/A 03/2019

NOTES:

1. All linear dimensions are in millimeters. Any dimensions in parenthesis are for reference only. Dimensioning and tolerancing per ASME Y14.5M.
2. This drawing is subject to change without notice.
3. This package complies to JEDEC MO-288 variation UDEE, except minimum package height.

EXAMPLE BOARD LAYOUT

RSW0010A

UQFN - 0.55 mm max height

PLASTIC QUAD FLATPACK - NO LEAD

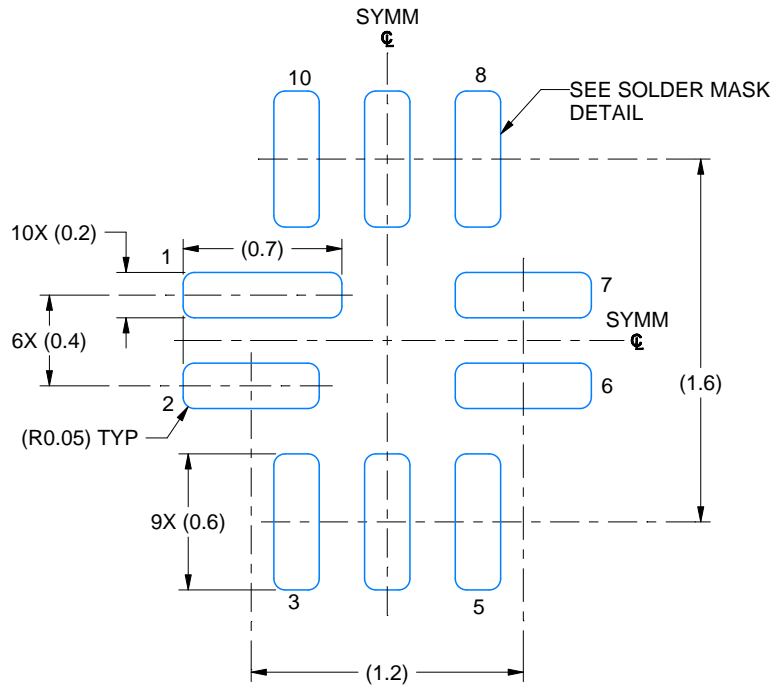

LAND PATTERN EXAMPLE
EXPOSED METAL SHOWN
SCALE: 30X

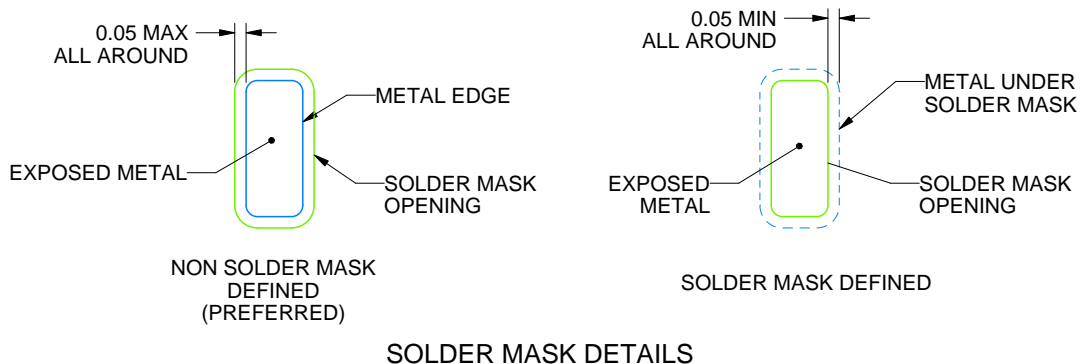

4224897/A 03/2019

NOTES: (continued)

- This package is designed to be soldered to a thermal pad on the board. For more information, see Texas Instruments literature number SLUA271 (www.ti.com/lit/slua271).
- Vias are optional depending on application, refer to device data sheet. If any vias are implemented, refer to their locations shown on this view. It is recommended that vias under paste be filled, plugged or tented.

EXAMPLE STENCIL DESIGN

RSW0010A

UQFN - 0.55 mm max height

PLASTIC QUAD FLATPACK - NO LEAD

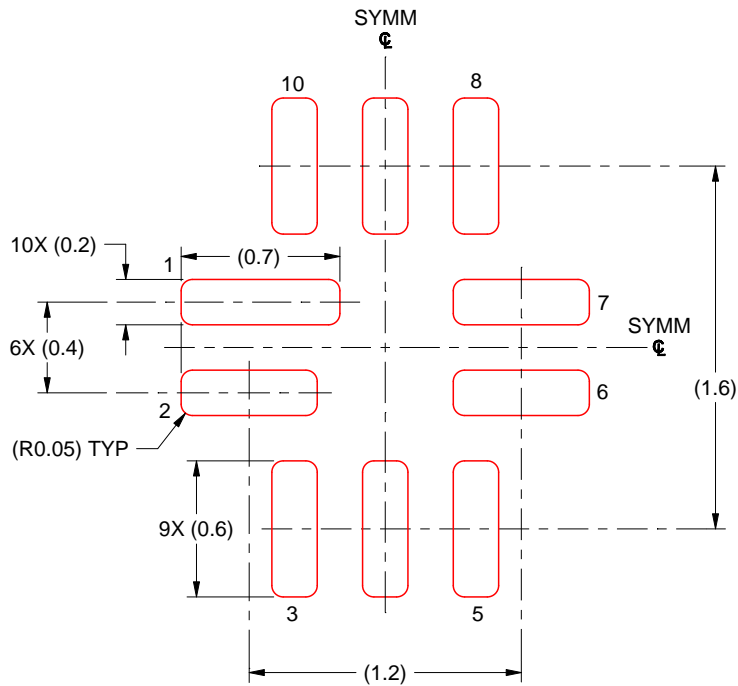

SOLDER PASTE EXAMPLE
BASED ON 0.125 MM THICK STENCIL
SCALE: 30X

4224897/A 03/2019

NOTES: (continued)

6. Laser cutting apertures with trapezoidal walls and rounded corners may offer better paste release. IPC-7525 may have alternate design recommendations.

DDF0008A



PACKAGE OUTLINE

SOT-23-THIN - 1.1 mm max height

PLASTIC SMALL OUTLINE



NOTES:

1. All linear dimensions are in millimeters. Any dimensions in parenthesis are for reference only. Dimensioning and tolerancing per ASME Y14.5M.
2. This drawing is subject to change without notice.
3. This dimension does not include mold flash, protrusions, or gate burrs. Mold flash, protrusions, or gate burrs shall not exceed 0.15 mm per side.

EXAMPLE BOARD LAYOUT

DDF0008A

SOT-23-THIN - 1.1 mm max height

PLASTIC SMALL OUTLINE



LAND PATTERN EXAMPLE
EXPOSED METAL SHOWN
SCALE:15X



SOLDER MASK DETAILS

4222047/E 07/2024

NOTES: (continued)

- 4. Publication IPC-7351 may have alternate designs.
- 5. Solder mask tolerances between and around signal pads can vary based on board fabrication site.

EXAMPLE STENCIL DESIGN

DDF0008A

SOT-23-THIN - 1.1 mm max height

PLASTIC SMALL OUTLINE



SOLDER PASTE EXAMPLE
BASED ON 0.125 mm THICK STENCIL
SCALE:15X

4222047/E 07/2024

NOTES: (continued)

6. Laser cutting apertures with trapezoidal walls and rounded corners may offer better paste release. IPC-7525 may have alternate design recommendations.
7. Board assembly site may have different recommendations for stencil design.

IMPORTANT NOTICE AND DISCLAIMER

TI PROVIDES TECHNICAL AND RELIABILITY DATA (INCLUDING DATA SHEETS), DESIGN RESOURCES (INCLUDING REFERENCE DESIGNS), APPLICATION OR OTHER DESIGN ADVICE, WEB TOOLS, SAFETY INFORMATION, AND OTHER RESOURCES "AS IS" AND WITH ALL FAULTS, AND DISCLAIMS ALL WARRANTIES, EXPRESS AND IMPLIED, INCLUDING WITHOUT LIMITATION ANY IMPLIED WARRANTIES OF MERCHANTABILITY, FITNESS FOR A PARTICULAR PURPOSE OR NON-INFRINGEMENT OF THIRD PARTY INTELLECTUAL PROPERTY RIGHTS.

These resources are intended for skilled developers designing with TI products. You are solely responsible for (1) selecting the appropriate TI products for your application, (2) designing, validating and testing your application, and (3) ensuring your application meets applicable standards, and any other safety, security, regulatory or other requirements.

These resources are subject to change without notice. TI grants you permission to use these resources only for development of an application that uses the TI products described in the resource. Other reproduction and display of these resources is prohibited. No license is granted to any other TI intellectual property right or to any third party intellectual property right. TI disclaims responsibility for, and you will fully indemnify TI and its representatives against, any claims, damages, costs, losses, and liabilities arising out of your use of these resources.

TI's products are provided subject to [TI's Terms of Sale](#) or other applicable terms available either on [ti.com](https://www.ti.com) or provided in conjunction with such TI products. TI's provision of these resources does not expand or otherwise alter TI's applicable warranties or warranty disclaimers for TI products.

TI objects to and rejects any additional or different terms you may have proposed.

Mailing Address: Texas Instruments, Post Office Box 655303, Dallas, Texas 75265
Copyright © 2024, Texas Instruments Incorporated

Looking for pricing, stock, or lifecycle information?

Click below to explore more details on WIN SOURCE:

 [View INA190A4IDCKR](#) on WIN SOURCE

 [Texas Instruments](#) Information

Optimize Your Supply Chain with WIN SOURCE Solutions

-  Global Sourcing Solution
-  Obsolete Management
-  Cost Control Management
-  Shortage Management
-  Alternative Solution
-  Excess Inventory Management