



THE DATASHEET OF
1376352-2



1. Part Names and Part Numbers

1.1 Housings

Part Number	Part Name
1565804	8Pos. Cap Housing Assembly
1376352	8Pos. Plug Housing Assembly
1473407	12Pos. Cap Housing Assembly
1318774	12Pos. Plug Housing Assembly
1473410	16Pos. Cap Housing Assembly
1318386	16Pos. Plug Housing Assembly
1473413	24Pos. Cap Housing Assembly
1318917	24Pos. Plug Housing Assembly

Fig.1

*Note : Part number is consisted from listed base number and 1 digit numeric prefix and suffix with dash. Refer to catalog or customer drawing for specific part numbers for each base number. When prefix is zero, zero and dash are omitted.

1.2 Contacts

AMP Part Number	Part Name	Wire Type (○ : Applicable, — : Not Applicable)			
		Type	0.22mm ²	0.3mm ²	0.5mm ²
1674298-1	025 Receptacle (Female Contact)	CAVUS/CAVS	○	○	○
		AVSS/AVSSH	—	○	○
1674742-1	025 TH Tab (Male Contact)	CAVUS/CAVS	—	○	○
		AVSS/AVSSH	—	○	○

Fig.2

1.3 Components View

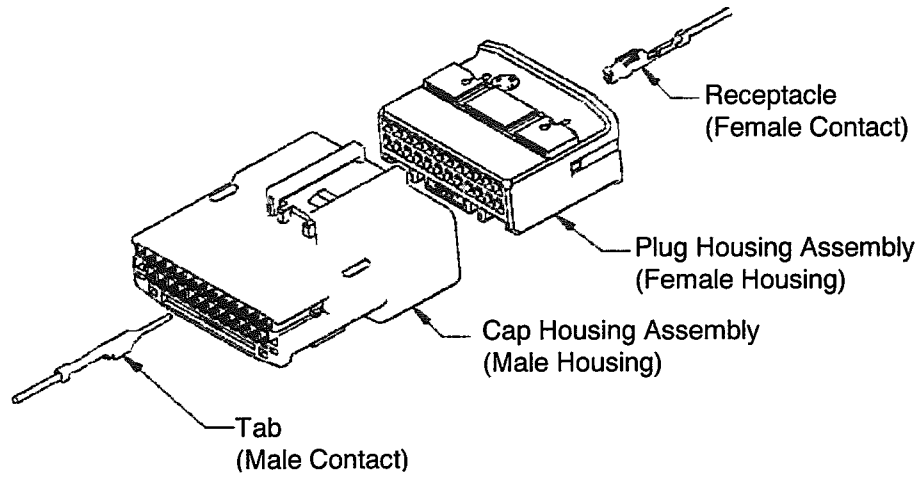

Fig.3

2. Customer Receiving Inspection

We conduct inspections according to our quality control regulations to maintain an over all lot control. In addition, the customers should conduct receiving inspections based on the specific customer drawings.

3.Storage and Carrying

3.1 Contact

- (1) Avoid leaving or carrying the contact reel in an open area without wrapping it in proper material.
- (2) Do not lift up and carry the contact reel by gripping one the side of reel, this may result in damage to the reel, and contacts before use. (See Fig.4)

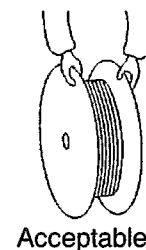
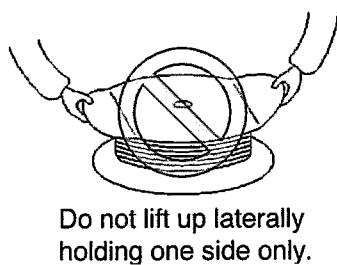

Fig.4

- (3) Avoid storing the contact reel in a moist or dusty place. Stock the reel in a comparatively dry and clean place (5~35°C, 45~85%RH) away from direct sunlight.

- (4) When removing the contact reel from the machine, fasten the end of contact strip onto the edge of the reel with use of proper string or wire. (See Fig.5)

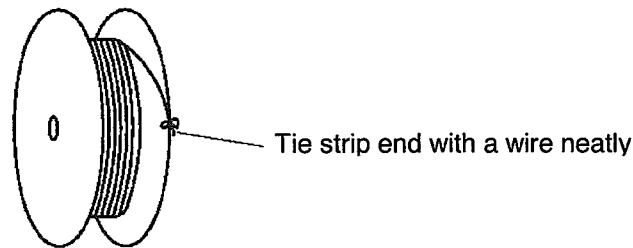

Fig.5

3.2 Housing

- (1) Avoid storing the contact reel in a moist or dusty place. Stock the reel in a comparatively dry and clean place (5~35°C, 45~85%RH) away from direct sunlight.
- (2) Avoid leaving or carrying the contact reel in an open area without wrapping it in proper material.
- (3) Do not drop or shock the housing when carrying it.

4. Crimping Operation

Using appropriate AMP tools according to the applicable Instruction Sheet and Specification must perform any crimping of contacts.

4.1 Wire

4.1.1 Applicable Wire

See Fig.2 for applicable wire.

4.1.2 Notes for Stripping of Wire End

Wire end must be stripped without nick, cutoff, or damage of wire strands.

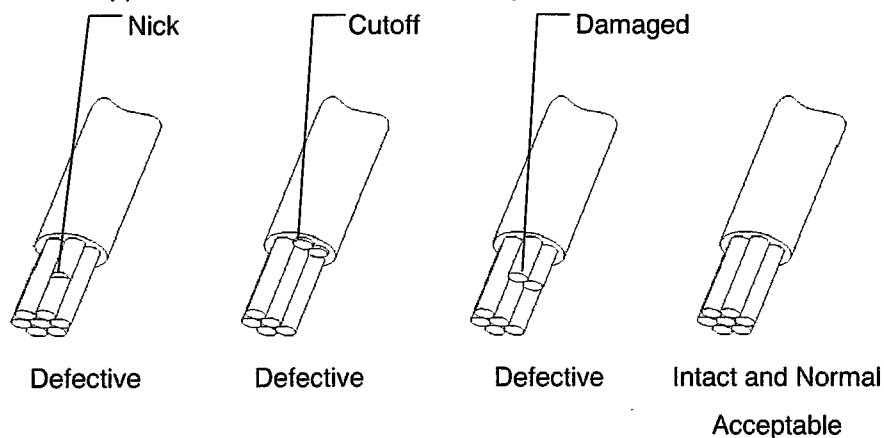

Fig.6

4.2 Operation of Crimping Machine

See the following instruction sheet for automatic terminating machine.

025 Tab & Receptacle	412-5022
----------------------	----------

4.3 Crimping Specification

See the following application specification.

025 Receptacle	114-5250-2
025 TH Tab	114-5340

4.4 Storage and Handling of Crimped Products

- (1) Store the products in a clean, dry area, cover with proper sheet or paper when placed in an open area until the next day.
- (2) Crimped leads should be processed in bundles.
 Take care of the tangle and damage (Specially the lance of contact and Tab contact) on the products.
- (3) Avoid stacking and piling up the in-process products in large volume.
 Contact failure and fall of retention force occur by deformation of the contact and specially lance.
- (4) Don't tap or hit the top of contacts for arranging them.
 Obstacle of mating and performance may be occurred by the damage of contact.

5. Harness Making

5.1 Procedure for Female Contact Insertion into Housing

- (1) Confirm the retainer is in pre-assembled condition. See para.5.3. The contact can not be inserted in final lock condition.

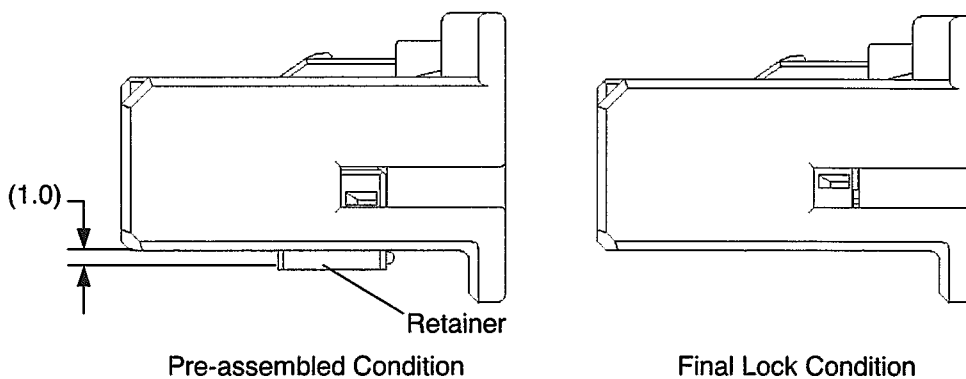

Fig. 7

(2) Confirm type of contact and housing.

It must be the same type of contact and housing. (Insert the male contact to the male housing and the female contact to the female housing)

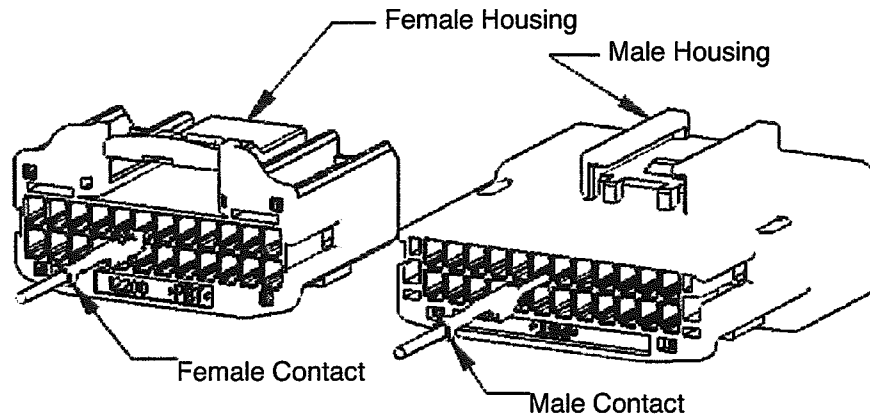

Fig.8

NOTE Should not insert the contact to different type housing.

If you insert different type, the contact and housing should be exchanged, not use.

(3) Insert the contacts into the housing with same direction as shown in Fig. 8. The insertion is finished when the lance is locked and the contact can not be more inserted.

(4) By pulling the contact lightly (MAX 20N), check to make sure that the contact can not be withdrawn.

NOTE When you insert contacts, you should have wire and take cares the breakage of lance and contact point.

5.2 Retainer (Secondary Lock) Operation

- (1) After insertion of all of the contacts, press the retainer for final lock condition. The double lock operation is finished by confirmation that the retainer is kept in the final condition by the 2 projections.

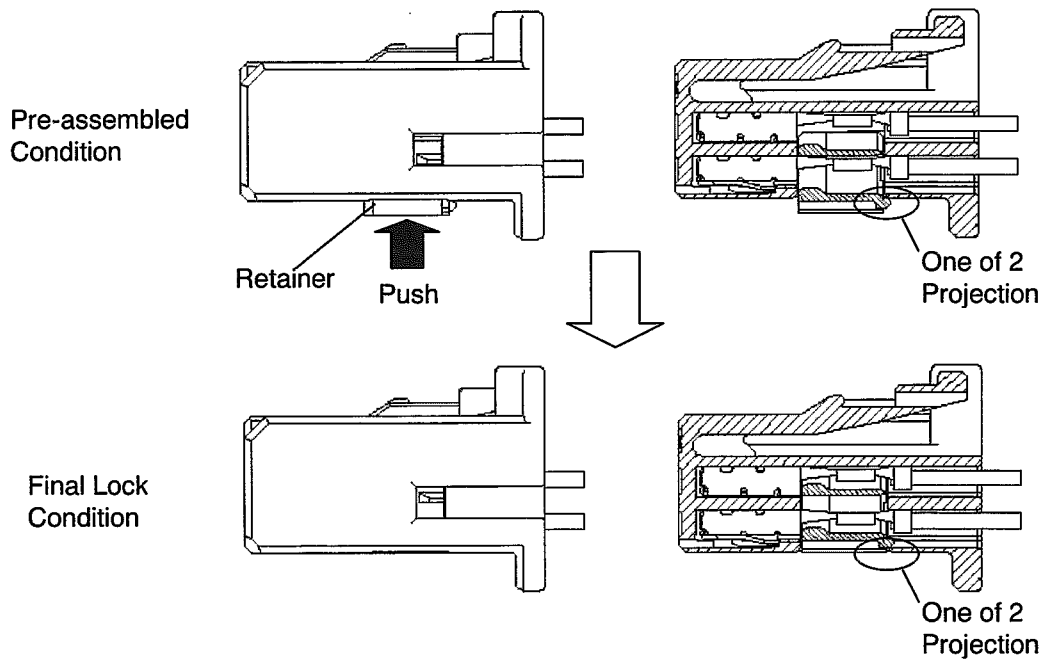

Fig.9

- (2) The double lock operation can not be completed if there are any half-inserted contacts. When the retainer can not be pressed to the final condition, do not press by force, find the half inserted contact, and insert it to proper position. See para.5.1.

5.3 How to Unlock Retainer from Final Lock Condition

When the contact requires insertion or extraction, the retainer must be in the pre-assembled condition. The insertion or extraction can not be done in final lock condition. (See Fig.10)

- (1) Insert the 1mm precision screwdriver into the window of the retainer pointed by the tear drop mark.
- (2) Draw out the retainer, about 1mm, to pre-assembled condition. Confirm that all of the projection is unlocked.

NOTE Do not extract the retainer more than appropriate length. Otherwise the retainer may be damaged.

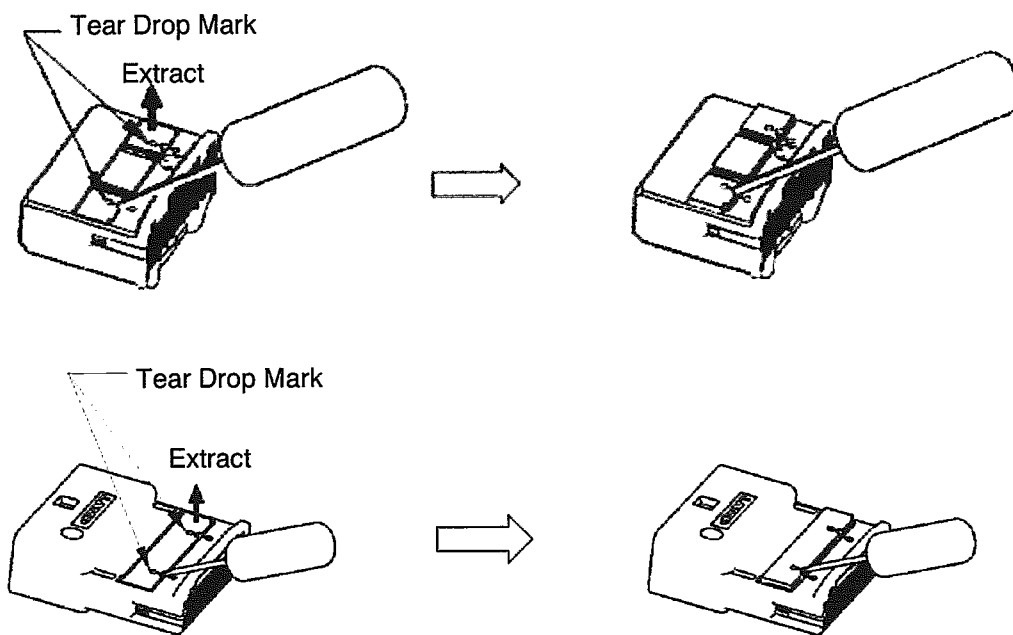

Fig.10

5.4 How to Extract Contact

Confirm the retainer is in pre-assembled condition. When the retainer is in final lock condition, it must be changed to pre-assembled condition. See para.3.3. The female contact can not be extracted in final assembled condition

(1) In the case of female contact

- ① Insert the special extractive jig (Part number:1276565-1) into the proper hole to the end.
- ② Remove the loaded contact from housing while the crimped wire. See Fig.11

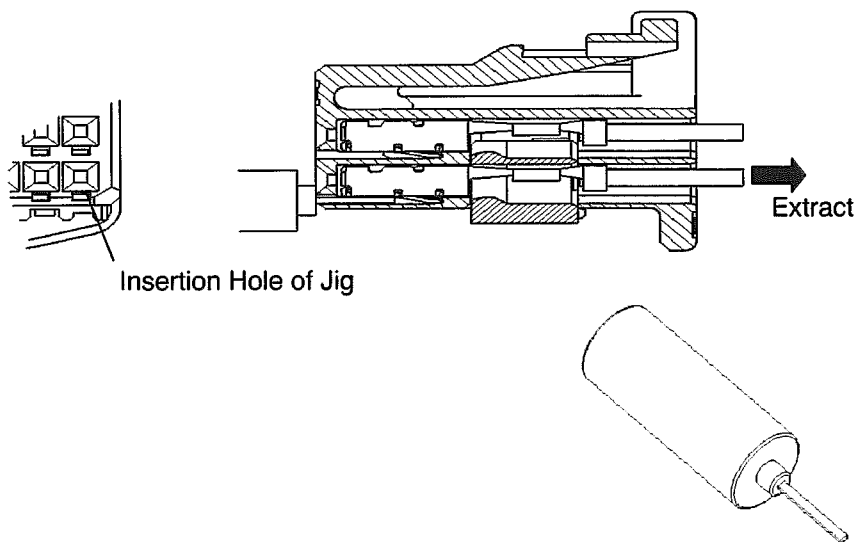

The part number of Special Extractive Jig for 025 female contact:

Fig.11

NOTE Do not insert the extractive jig into the female contact. If you insert this, the contact should be exchanged, not use.

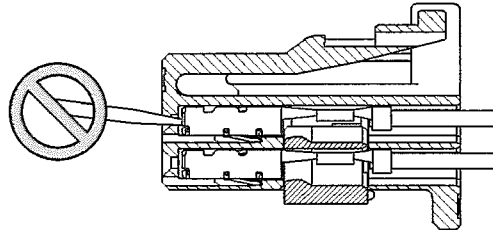
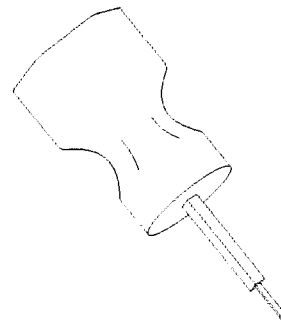
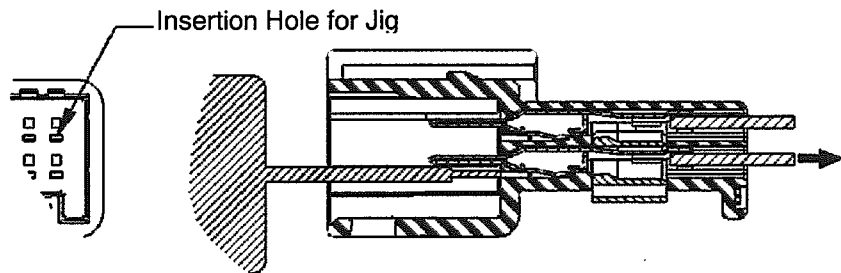

Fig.12

(2) In the case of male contact

- ① Insert the special extractive jig (Part number:1366865-1) into the proper hole to the end.
- ② Remove the loaded contact from housing while the crimped wire. See Fig.13.



The part number of Special Extractive Jig for 025 Male contact: 1366865-1

Fig.13

NOTE Attend to the crack and break of male contact, when you insert the extractive jig. If you find them, the contact should be exchanged, not use.

NOTE If you can't extract the contact, pull out the jig, and then push contact with having wire, insert the jig again.

Don't extract the contact more than 10 times.

NOTE Do not extract the retainer by this extractive jig.

NOTE Attend to the crack and break of contact and housing, when you insert the extractive jig.

5.5 Control of Harness

5.5.1 Handling

Don't apply excess force or shock to the connector and wire.

5.5.2 Taping up wire

Tape up the wire at intervals of more than 30mm from the end of housing, not apply excess force to the wires.

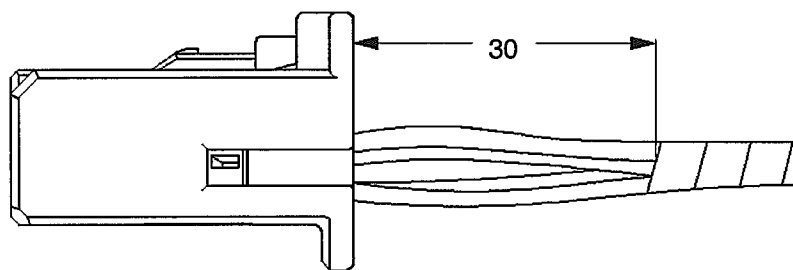

Fig.14

5.5.3 Inspection of Electric Circuit

(1) For inspection of electric circuit, use the applicable mating connector or equivalent.

(2) Must not insert the probe pin for the inspection into the female contact. Put the probe pin from the wire side.

NOTE Exchange the contact, if insert the probe pin into the female contact.

5.5.4 Storage

Avoid storing the connector in a moist or dusty place. Stock the connector away from direct sunlight.

5.5.5 Shipping and Carrying

The connector should be used with the proper packaging to prevent the ingress of dust, moisture, etc.

6. Mating and Unmating of connector

6.1 Mating of connector

(1) Check the condition of contact inserted into housing, the position of taping up wire, and the lock of retainer. If the retainer is in pre-assembled condition, press the retainer for final lock condition.

(2) Check the defects, deformation, discoloration, damage, rust, crack, deficit, etc. of housing and contact.

NOTE Exchange the connector, if any defects are found.

- (3) Insert the proper female housing straight into the male housing with the direction shown on Fig.14. If the operation is finished, you can hear the click sound and can't insert further. Don't apply excess force, if you can't insert into the male housing, and check the items of (1) and (2).

NOTE Don't apply excess force without the insertion direction at inserting.

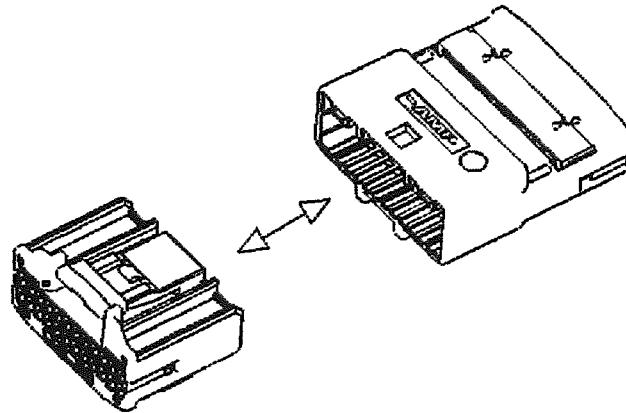

Fig.15

- (4) Check the connector can not be withdrawn by pulling the female connector lightly.

6.2 Unmating of Connector

Grip the male and female housing, then draw straight out while pressing down the locking lever. If the housing can not be drawn out, do not pull by excess force but check to make sure if the locking mechanism is released.

NOTE Don't apply excess force without the insertion direction at unmating.

NOTE Don't pull only the wire.

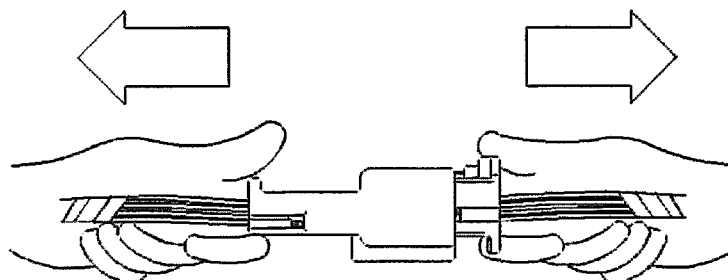

Fig.16

6.3 General Attention Matters



- (1) Don't mate and unmate the connector unnecessarily.
- (2) Don't insert any objects except the proper connector.
- (4) Don't apply unnecessary force or shock to the wire and connector at mating and unmating operation.

7. Installation of connector to vehicles





- (1) Don't force to pull connector out, when you run the connector through the hole of vehicle.
- (2) At inserting to bracket,
 - ① Take male and female housing.
 - ② Check position and direction between bracket and cassette.
 - ③ Don't apply excess force without the insertion direction at inserting
- (3) If the operation is finished, you can hear the click sound.

Looking for pricing, stock, or lifecycle information?

Click below to explore more details on WIN SOURCE:

-  [View 1376352-2 on WIN SOURCE](#)
-  [TE Connectivity](#) Information

Optimize Your Supply Chain with WIN SOURCE Solutions

-  Global Sourcing Solution
-  Obsolete Management
-  Cost Control Management
-  Shortage Management
-  Alternative Solution
-  Excess Inventory Management