



**THE DATASHEET OF
AL8853AQS-13**



Description

The AL8853AQ is an automotive AEC-Q100 highly integrated and cost-effective boost controller and single-ended primary-inductance controller (SEPIC). It provides a high-performance LED lighting solution with low BOM (bill of material) cost.

The AL8853AQ contains a PWM (pulse-width modulation) boost/SEPIC control which uses current-mode and fixed-frequency operation to regulate the LED current. The LED current is sensed through an external current-sense resistor. The voltage across the sensing resistor is compared with reference level of 200mV. The error is amplified to control the pulse width of the power switch thus to regulate the current flowing into the LED.

The AL8853AQ offers PWM converted to analog DC dimming mode for a wide range of dimming control.

The AL8853AQ has comprehensive protection features such as power MOSFET overcurrent protection (OCP), output overvoltage protection (OVP), diode & inductor short protection, LED cathode short to GND protection, IC power-supply undervoltage lockout (UVLO), LED open protection, V_{OUT} short protection and overtemperature protection (OTP).

The AL8853AQ is available in the SO-8 package.

Features

- AEC-Q100 Grade 1 Qualified
- Wide Input-Voltage Range: 6.0V to 40V
- High-Precision Feedback Reference Voltage: 200mV/±3%
- Current-Mode PWM Controller with Good Dynamic Response
- PWM to Analog Dimming Mode
- Fixed 400kHz Switching Frequency
- Built-In Comprehensive Protections
 - Undervoltage Lockout (UVLO)
 - Output Overvoltage Protection (OVP)
 - Power MOSFET Overcurrent Protection (OCP)
 - Diode- and Inductor-Short Protection
 - LED Cathode Short-to-GND Protection
 - LED-Open Protection
 - V_{OUT} Short Protection
 - Overtemperature Protection (OTP)
- Available in Pb-Free SO-8 package
- **Totally Lead-Free & Fully RoHS Compliant (Notes 1 & 2)**
- **Halogen and Antimony Free. "Green" Device (Note 3)**
- **The AL8853AQ is suitable for automotive applications requiring specific change control; this part is AEC-Q100 qualified, PPAP capable, and manufactured in IATF 16949 certified facilities.**

<https://www.diodes.com/quality/product-definitions/>

- Notes:
1. No purposely added lead. Fully EU Directive 2002/95/EC (RoHS), 2011/65/EU (RoHS 2) & 2015/863/EU (RoHS 3) compliant.
 2. See <https://www.diodes.com/quality/lead-free/> for more information about Diodes Incorporated's definitions of Halogen- and Antimony-free, "Green" and Lead-free.
 3. Halogen- and Antimony-free "Green" products are defined as those which contain <900ppm bromine, <900ppm chlorine (<1500ppm total Br + Cl) and <1000ppm antimony compounds.

Pin Assignments

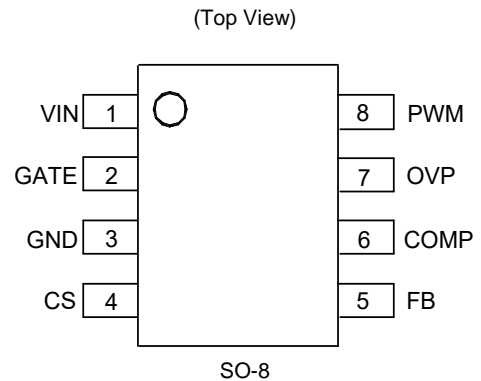

Applications

- Automotive LED lamps
- Fog lights, reversing lights, daytime running lights
- Head lamps
- Auto head-up displays
- Infotainment and cluster backlight displays
- DC-DC power conversion

Typical Applications Circuit

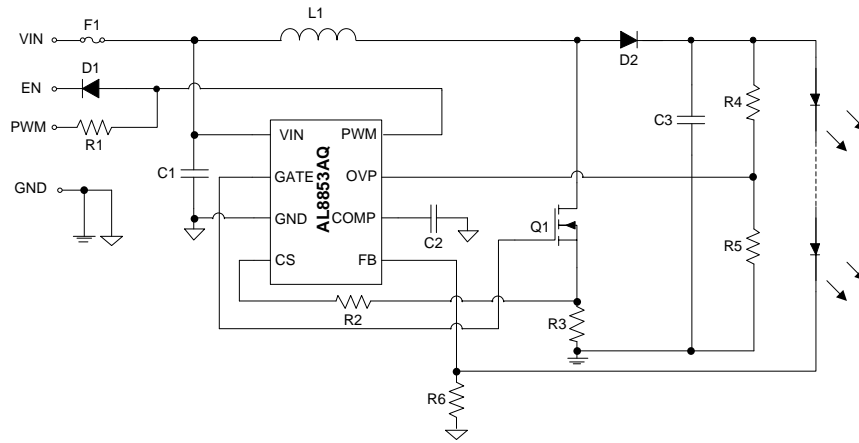

Figure 1. Typical Boost Schematic for Constant Current Output Application

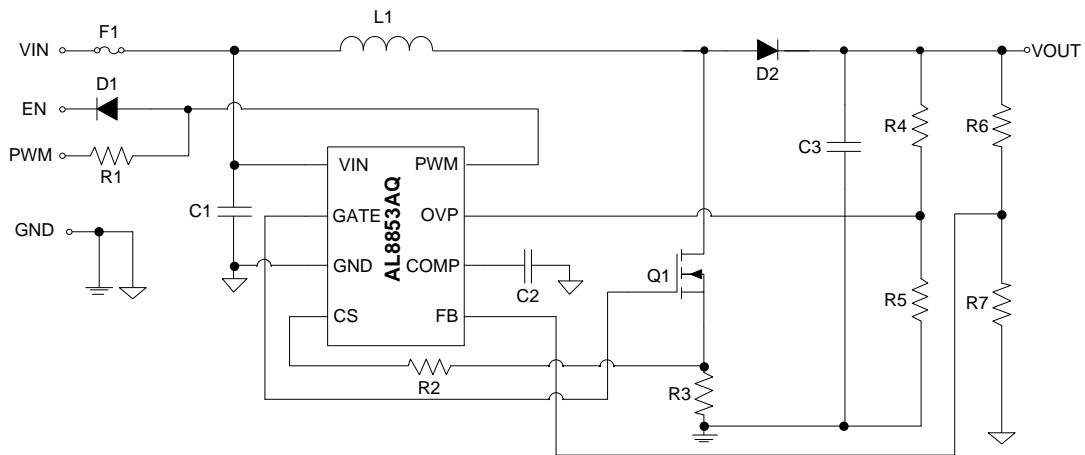

Figure 2. Typical Boost Schematic for Constant Voltage Output Application

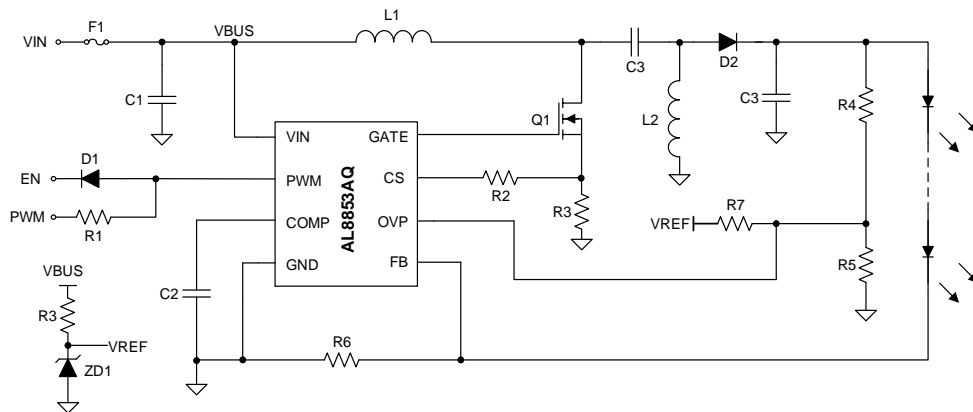
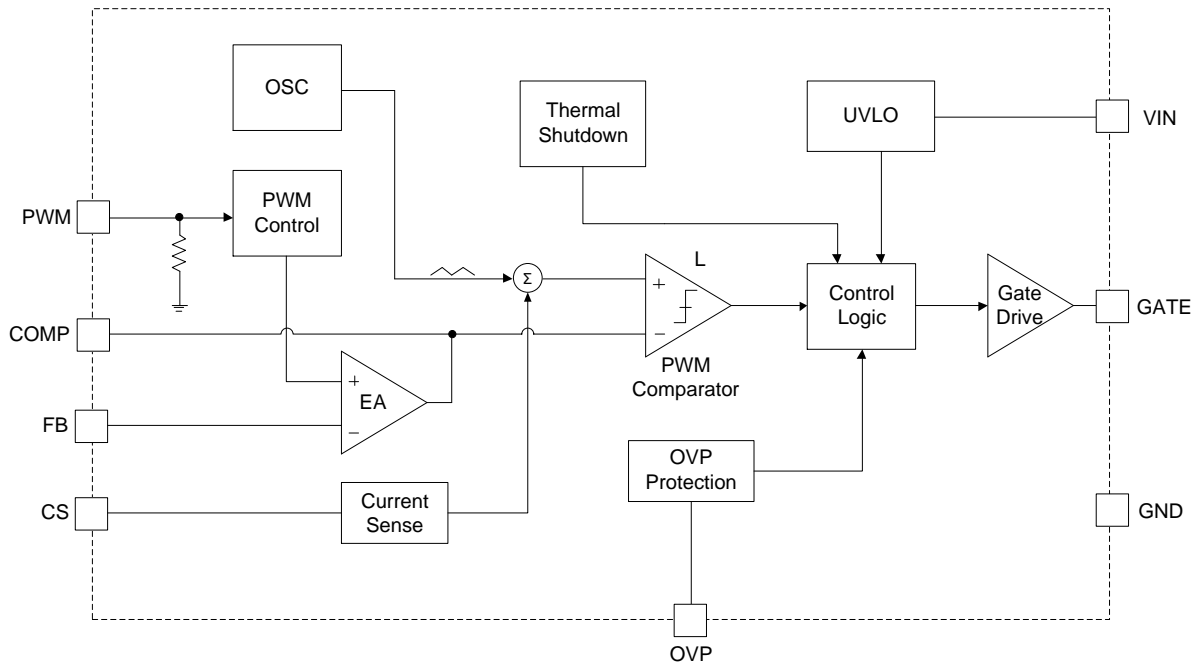

Figure 3. Typical SEPIC Schematic for Constant Current Output Application

Pin Descriptions

Pin Number	Pin Name	Function
1	VIN	Power-Supply Input
2	GATE	Gate Drive Output
3	GND	Ground
4	CS	Current-Sense Input
5	FB	LED Current Feedback
6	COMP	Boost-Controller Loop Compensation
7	OVP	Overvoltage Protection Sense
8	PWM	PWM Signal Input for Analog Dimming Control

Functional Block Diagram



Absolute Maximum Ratings (@T_A = +25°C, unless otherwise specified.) (Note 4)

Symbol	Parameter	Rating	Unit
V _{IN} , V _{GATE} , V _{OVP}	V _{IN} , GATE, OVP Pin Voltage	-0.3 to 43	V
V _{CS} , V _{FB} , V _{COMP} , V _{PWM}	CS, FB, COMP, PWM Pin Voltage	-0.3 to 7	V
T _J	Operating Junction Temperature	+160	°C
T _{STG}	Storage Temperature Range	-65 to +150	°C
T _{LEAD}	Lead Temperature (Soldering, 10sec)	+260	°C
θ _{JA}	Thermal Resistance (Junction to Ambient) (Note 5)	123	°C/W
θ _{JC}	Thermal Resistance (Junction to Case) (Note 5)	17	°C/W
—	ESD (Charged Device Model)	750	V
—	ESD (Human Body Model)	2000	V

Notes: 4. Stresses greater than those listed under *Absolute Maximum Ratings* can cause permanent damage to the device. These are stress ratings only and functional operation of the device at these or any other conditions beyond those indicated under *Recommended Operating Conditions* is not implied. Exposure to *Absolute Maximum Ratings* for extended periods can affect device reliability.
 5. Device mounted on 1"x1" FR-4 substrate PCB, 2oz copper, with minimum recommended pad layout.

Recommended Operating Conditions

Symbol	Parameter	Min	Max	Unit
V _{IN}	VIN Pin Voltage	6	40	V
f _{PWM}	PWM Frequency for PWM Converted to Analog DC Dimming	5	50	kHz
T _J	Operating Junction Temperature	-40	+150	°C
T _A	Ambient Temperature	-40	+125	°C

Electrical Characteristics (V_{IN} = 12V, V_{PWM} = 5V, @T_A = -40°C to +125°C, unless otherwise specified.) (Note 6)

Symbol	Parameter	Conditions	Min	Typ	Max	Unit
Supply Voltage						
V _{IN}	Input Voltage	—	6.0	—	40	V
I _{OP}	Operating Supply Current	V _{IN} = 12V, V _{PWM} = 5V, No Load	—	2	3	mA
I _{SHDN}	Shutdown Supply Current	PWM Low > 50ms, Sleep Mode	—	55	180	μA
Undervoltage Lockout						
V _{UVLO}	Input UVLO Threshold	V _{IN} Rising	4.8	5.4	6	V
V _{HYS}	Input UVLO Hysteresis	—	—	400	—	mV
Soft-Start						
I _{SS_SLOP}	Soft-Start Slope	—	—	22	—	mV/ms
Error Amplifier and Current Sense						
V _{FB}	Feedback Reference Voltage	Reference Voltage at Non-Inverting Input T _A = +25°C	194	200	206	mV
		T _A = -40°C to +125°C	190	200	215	mV
A _m	Open-Loop Voltage Gain	—	—	70	—	dB
G _m	Transconductance of EA	—	—	100	—	μA/V
I _{SOURCE}	Output Source Current	—	—	30	—	μA
I _{SINK}	Output Sink Current	—	—	60	—	μA
K _{CS}	DC Gain of Current Sense	Input-to-Output Gain at DC, V _{CS} < 1V	0.6	1	1.4	—
PWM to Analog Dimming Control						
—	PWM Duty Input Range	—	0	—	100	%
V _{PWM_H}	PWM Logic Input for Analog Dimming	—	2.5	—	—	V
V _{PWM_L}		—	—	—	1.2	V
Protection Threshold						
V _{OVP_OV}	Output Overvoltage Threshold Voltage	—	1.9	2.0	2.1	V
V _{OVP_UVLO}	OVP UVLO Threshold Voltage	Normal Operation	—	200	—	mV
		System Startup	—	100	—	mV
V _{CS_OCP}	Overcurrent Threshold Voltage	Duty = 90%	255	300	345	mV
V _{CS_HIGH}	CS High-Protection Threshold	Diode or Inductor Short	1.1	1.2	1.3	V
V _{COMP_HIGH}	COMP High-Protection Threshold	FB Short to GND	2.9	3.2	3.5	V
T _{OTP}	Overtemperature Threshold	—	—	+160	—	°C
Gate Driver						
f _{OSC}	Oscillator Frequency	—	360	400	430	kHz
D _{MAX}	Max Duty Cycle	—	91	93	95	%
V _{GATE}	Gate Pin Output Voltage	V _{IN} = 24V	—	13	—	V
t _{RISE}	Rising Time	1nF Load	—	40	—	ns
t _{FALL}	Falling Time		—	20	—	ns

Note: 6. These parameters, although guaranteed by design, are not 100% tested in production.

Performance Characteristics

Oscillator Frequency vs. Ambient Temperature

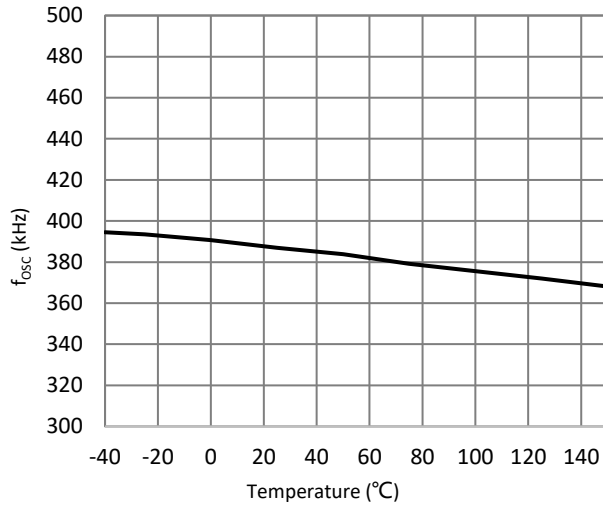

Reference Voltage vs. Ambient Temperature

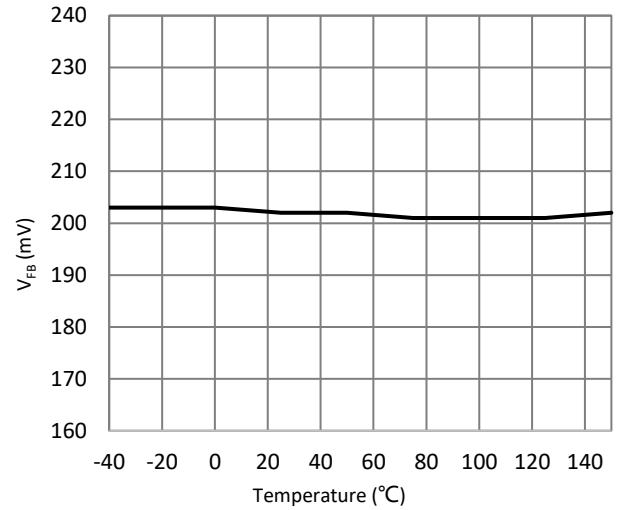

Shutdown Supply Current vs. Ambient Temperature

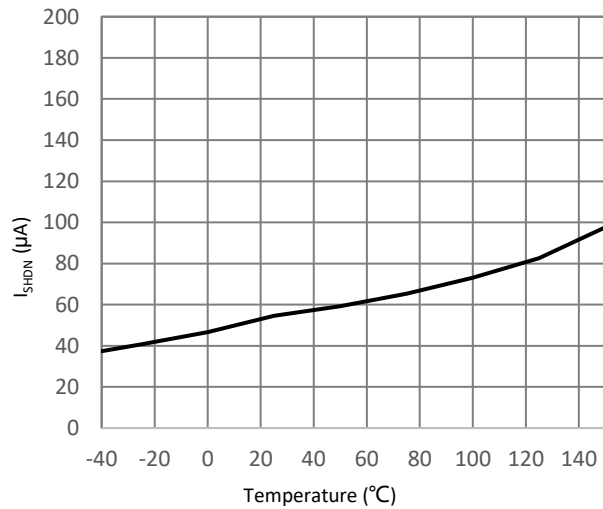

Operating Supply Current vs. Ambient Temperature

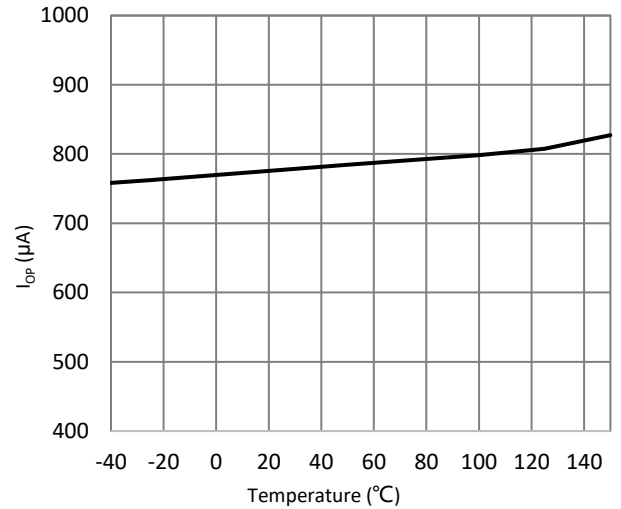

Input UVLO Threshold (V_{IN} Rising) vs. Ambient Temperature

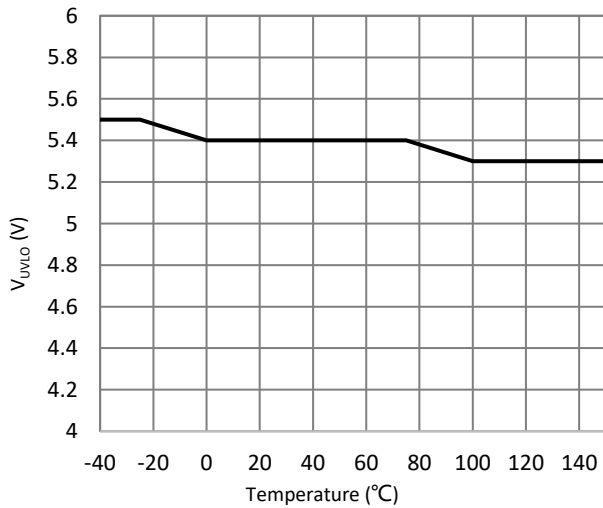

Overvoltage Threshold Voltage vs. Ambient Temperature

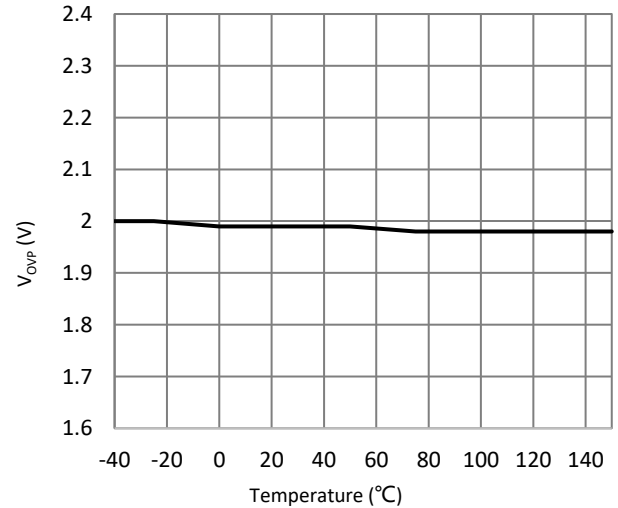

Performance Characteristics (continued)

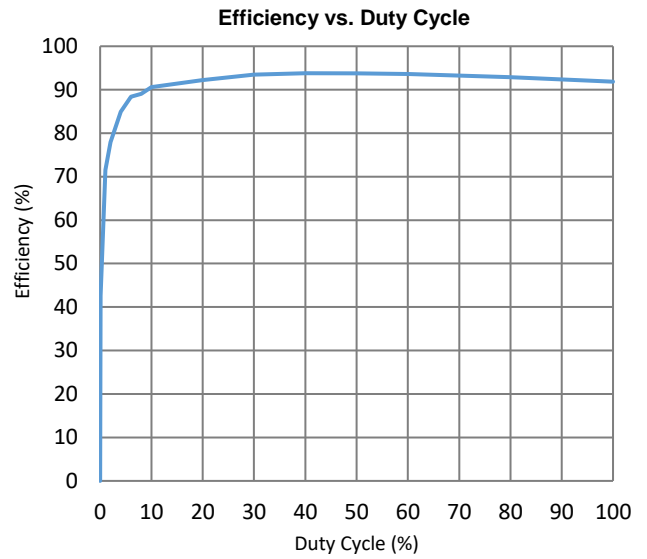
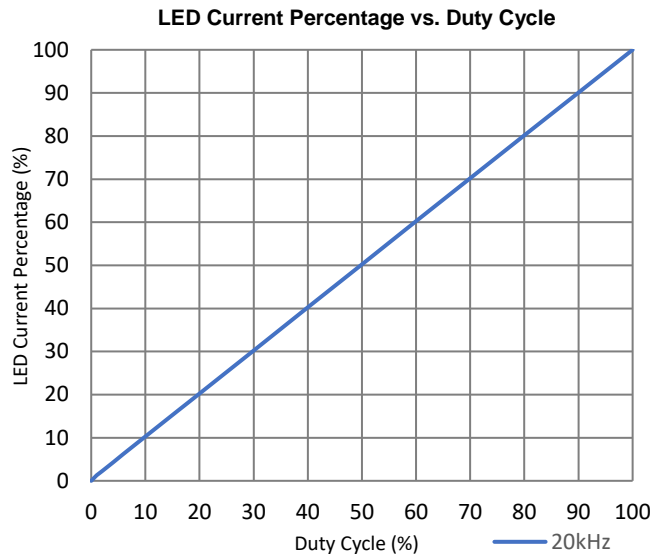

Functional Description

The AL8853AQ is a LED driver controller designed for boost and SEPIC controllers in a constant-frequency mode. It implements a peak current-mode control scheme and an internal transconductance amplifier to accurately control the output current over a wide input and load conditions.

The AL8853AQ has comprehensive protection features such as power MOSFET overcurrent protection (OCP), output overvoltage protection (OVP), diode & inductor short protection, LED cathode short to GND protection, IC power-supply undervoltage lockout (UVLO), LED open protection, V_{out} short protection and overtemperature protection (OTP).

Startup

AL8853AQ is enabled by applying a voltage of greater than 2.5V to the PWM pin. The PWM pin is pulled down to GND with an on-chip 220kΩ resistor. When the first rising edge is applied to the PWM pin, the AL8853AQ will power up immediately, and remains powered up until the PWM input is lower than 1.3V for at least 20ms (typical). At this time the IC will enter standby mode. At standby mode, the current consumption of the AL8853AQ will be lower than 130μA (typical). Once AL8853AQ is enabled, the internal 5V regulator will be activated and consumes less than 4mA.

When PWM is active-high, the AL8853AQ checks the topology connection first. The IC monitors the OVP pin to see if the boost Schottky diode is connected or the output is short to GND. If the voltage at OVP pin is lower than 100mV, the output will be disabled. Due to the output voltage is zero before system startup in SEPIC application, it's necessary to supply a 0.2V offset on OVP pin for SEPIC topology, otherwise system may not start up normally. The AL8853AQ will also check other faults (UVLO, CS high, CMP high, FB high, OCP and OTP), and the boost controller will boost up the output with the internal soft-start if no fault conditions.

UVLO

AL8853AQ contains an undervoltage lockout (UVLO) protection. AL8853AQ is not turned on until the power supply V_{IN} has reached 5.4V (typical). Whenever the input voltage falls below approximately 5.0V (typical), the device is turned off. The UVLO circuit has a hysteresis of 400mV.

LED Current Regulation

The AL8853AQ senses the FB pin voltage to control the LED current. The error between the sensed voltage and the internal FB reference voltage is amplified and compared to the CS pin sensing current signal plus the slope compensation to determine the power MOSFET on-time. The error amplifier sources or sinks current to the COMP pin to adjust the required inductor current responding to the load changes. The slope compensation signal is added to the current-sense signal to guarantee system stability at high duty cycle.

The error amplifier reference is set by internal reference voltage and the PWM duty cycle at PWM pin. And the average LED current is approximated by Equation 1:

$$I_{LED} [mA] = \frac{200mV \cdot DUTY}{R_{FB}[\Omega]} \dots\dots\dots (1)$$

AL8853AQ enters the pulse-skip mode at light load to improve efficiency and prevent overcharging the output capacitor. AL8853AQ turns the GATE signal high for a minimum on-time (typical 600ns), and remains low until another pulse is needed to maintain the boost-controller output voltage.

Dimming Control

The LED current is controlled by the external PWM signal with different duty cycles. The AL8853AQ can support PWM signals with frequency ranging from 5kHz to 50kHz, and the PWM signal shall be higher than 2.5V for high logic and be lower than 1.3V for low logic. An internal square wave with duty cycle same as the external PWM signal is filtered to provide reference voltage of EA input, which determines the FB reference.

Slope Compensation

The AL8853AQ adopts a peak current-mode control scheme. The main advantages of current mode are inherent cycle-by-cycle current limit of the power MOSFET and simple control loop characteristics. However, current-mode control could cause the sub-harmonic oscillation for duty cycles greater than 50%, leading to system instability. The AL8853AQ has a build-in slope compensation to avoid the sub-harmonic oscillation.

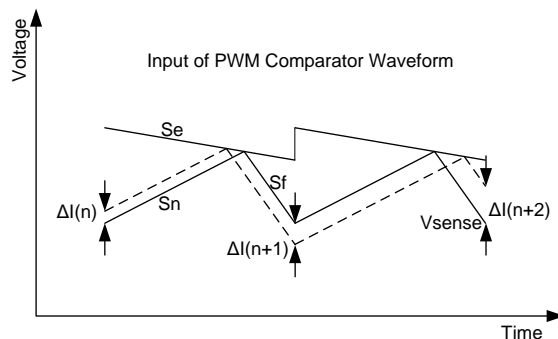

Figure 4. Sub-Harmonic Oscillation at Duty > 50% and Compensation Slope to Avoid Sub-Harmonic Oscillation

Functional Description (continued)

In Figure 4, $\Delta I(n)$, $\Delta I(n+1)$ and $\Delta I(n+2)$ represent the inductor current increments when there is disturbance in the inductor current. And the relationship of the inductor current increments can be calculated with Equation 2:

$$\Delta I_{(n+1)} = \frac{S_f - S_e}{S_n + S_e} \cdot \Delta I_{(n)} \dots\dots\dots (2)$$

Where S_n is the slope of the inductor current when rising, S_f is the slope of the inductor current when falling and S_e is the slope of control signal.

If the control signal has no compensation, the inductor current ramps up till slope reaches the control signal, and then ramps down. If the PWM duty is higher than 50%, the distribution will not be converged from duty to duty, and system runs into sub-harmonic oscillation. To avoid sub-harmonic oscillation, a control compensation is needed and $(S_f - S_e) / (S_n + S_e)$ should always be smaller than 1. For boost applications, the slopes S_e , S_f and S_n can be calculated with the equations below:

$$S_e = V_{SL} \cdot f_s \dots\dots\dots (3)$$

$$S_f = R_{sen} \cdot (V_{OUT} - V_{IN}) / L \dots\dots\dots (4)$$

$$S_n = R_{sen} \cdot V_{IN} / L \dots\dots\dots (5)$$

Where R_{sen} is the current-sense resistance and typical value of V_{SL} is 100mV.

From the equations, the factor $(S_f - S_e) / (S_n + S_e)$ will decrease if S_e increases. When the duty cycle is greater than 50%, lower inductance can also result in the factor increase. And for more flexibility, slope compensation amplitude can be increased by adding one external resistor, R_{SL} , in the CS path. Figure 5 shows the circuit setup. The externally generated slope compensation is then added to the internal slope compensation of the AL8853AQ. When using external slope compensation, the equation for S_e becomes:

$$S_e = (V_{SL} + I_s \cdot R_{SL}) \cdot f_s \dots\dots\dots (6)$$

Where I_s typical value is 50 μ A.

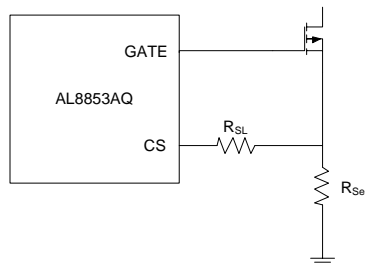

Figure 5. Adding External Slope Compensation

It is a good design practice to only add as much slope compensation as needed to avoid sub-harmonic oscillation. Additional slope compensation minimizes the influence of the sensed current in the control loop. With very large slope compensation, the control loop characteristics are similar to a voltage-mode regulator which compares the error voltage to a saw tooth waveform rather than the inductor current.

LED Open Protection

AL8853AQ shuts down the output if the output voltage is higher than the preset threshold level. When LED open failure happens, the LED current and the resulted voltage drop on sensing resistor is nearly zero; the controller will run at maximum duty cycle that boosts the output voltage to a very high level. To prevent this from happening, the output voltage is monitored through the OVP pin, and the controller is shut down and the COMP capacitor is discharged if the output voltage exceeds the preset level. A soft-start sequence is initiated once the voltage on OVP pin drops below the hysteresis threshold (100mV).

LED Cathode Short to GND Protection

When the LED cathode is short to GND, the output voltage will increase to the OVP voltage and IC will turn off the GATE signal. However, in some conditions, if the output power is limited by the OCP protection before the output voltage reaches the OVP voltage, the GATE will never be turned off. In this case, large current goes through both the power MOSFET and Schottky diode, and leads to damages. To enhance safety, the AL8853AQ monitors the voltage on the COMP pin and latches the GATE signal if the COMP voltage is continuously greater than 3.2V for 37ms.

Functional Description (continued)

Diode & Inductor Short Protection

When the Schottky diode or the inductor is short, the current of the power MOSFET increases significantly, which would cause the MOSFET damage if the IC continues working. AL8853AQ monitors the voltage on the CS pin cycle by cycle. If the CS pin voltage is greater than 1.2V (typical) for continuous 17 cycles, the IC will latch and shut down the GATE output to prevent the MOSFET from permanent damage.

V_{OUT} Short Protection

V_{OUT} short condition is monitored by the voltage at OVP pin. In normal operation, when the OVP voltage drops below a threshold of approximately 0.2V (typical), V_{OUT} short protection is triggered and the GATE turns off. This state latched can be reset from VIN or PWM.

Thermal Shutdown

The AL8853AQ includes a thermal protection circuit to ensure that the system will not run into condition of thermal runaway and blow up. When the junction temperature exceeds +160°C, AL8853AQ shuts down. And if the junction temperature falls below +135°C, AL8853AQ will automatically restart.

Application Information

Constant Voltage Application

Besides boost controller for LED driver applications, the AL8853AQ can also be applied in constant output-voltage boost applications. Figure 2 shows the typical circuit schematic for constant voltage applications.

To make the output voltage constant, a resistor divider (R6 and R7 in Figure 2) is added and the FB pin is connected to sense the divided output voltage. The output voltage V_{OUT} is set with Equation 7:

$$V_{OUT} = \frac{R_6 + R_7}{R_7} \cdot 0.2V \dots\dots\dots (7)$$

For the OCP setting, OVP setting, inductor design, power MOSFET selection and Schottky diode selection, the above configuration guides for LED driver are also applicable.

Constant Current Application

The AL8853AQ is a highly integrated and cost-effective LED controller optimized for automotive LED lamp applications. It provides a high-performance LED lighting solution with low BOM cost.

To build a boost or SEPIC constant current control with AL8853AQ, several configurations are in need. The LED current, OCP and OVP should be set with corresponding resistors, and proper inductor, power MOSFET and Schottky diode should be selected.

LED Current Setting

The LED current is controlled by the feedback resistor (R6 in Figure 1 and Figure 3). LED current accuracy is determined by the regulator's feedback threshold accuracy and is independent of the LED's forward voltage variation. So, precision resistors are preferred:

$$I_{LED} = \frac{200mV}{R_{FB}} \text{ (mA)} \dots\dots\dots (8)$$

Inductor Design

An inductor is the energy-storage component in a controller. Designing an inductor means specifying its size, structure, material, inductance, saturation level, DC-resistance (DCR), and core loss. The peak-to-peak inductor ripple current can be calculated with Equation 9 for boost controller:

$$I_{P-P} = \frac{V_{IN} \cdot (V_{OUT} - V_{IN})}{V_{OUT} \cdot L \cdot f} \text{ (Boost)} \dots\dots\dots (9)$$

And Equation 10 for SEPIC control:

$$I_{P-P} = \frac{V_{IN} \cdot V_{OUT}}{(V_{IN} + V_{OUT}) \cdot L \cdot f} \text{ (SEPIC)} \dots\dots\dots (10)$$

Where V_{IN} is the input voltage, V_{OUT} is the output voltage, f is the switching frequency, and L is the inductance.

The average inductor current for boost and SEPIC can be calculated with Equation 11, in which η is the conversion efficiency:

$$I_L = \frac{I_{LED} \cdot V_{OUT}}{V_{IN} \cdot \eta} \text{ (Boost & SEPIC)} \dots\dots\dots (11)$$

And the inductor current ripple rate for boost and SEPIC is defined with Equation 12:

$$\gamma = \frac{I_{P-P}}{I_L} \text{ (Boost & SEPIC)} \dots\dots\dots (12)$$

Application Information (continued)

Higher inductance means lower ripple current, lower RMS (root mean square) current, lower voltage ripple on both input and output, and higher efficiency unless the resistive loss of the inductor dominates the overall loss. However, higher inductance also means a bigger inductor size and a slower response to transients. For optimal practical design, the inductor current ripple rate γ is set 0.3 to 0.5.

The saturation level is another important parameter in designing inductor.

The maximum peak inductor current can be calculated with Equation 13:

$$I_{PK} = \frac{I_{LED} \cdot V_{OUT}}{V_{IN} \cdot \eta} + \frac{I_{P-P}}{2} \dots\dots\dots (13)$$

The inductor saturation current should be higher than the inductor peak current with a reasonable margin.

Considering the system efficiency, cost requirements and the peak inductor current limitations, an inductor is then designed accordingly.

OCP Setting

To protect the power MOSFET from overcurrent and other anomalies, AL8853AQ integrates an overcurrent protection (OCP) function. AL8853AQ senses the CS pin voltage and enters the OCP protection when the threshold voltage is touched. The OCP current should be set 30% higher than the maximum peak inductor current at the lowest input voltage and full load output. The OCP resistor (R3 in Figure 1) sets the desired OCP current with the Equation 14:

$$R_{OCP} = \frac{300mV}{I_{OCP}} \dots\dots\dots (14)$$

OVP Setting

AL8853AQ shuts down the output if the output voltage is higher than the preset output threshold voltage. The threshold voltage must be set higher than the nominal output voltage with at least 20% margin to avoid mis-trigger. The threshold voltage is set by a resistor divider (R4 and R5 in Figure 1) with Equation 15:

$$V_{OUT_OVP} = \frac{R_4 + R_5}{R_5} \cdot 2V \dots\dots\dots (15)$$

The output threshold voltage cannot be set to a much too high voltage, since the AL8853AQ monitors the OVP pin voltage during startup and shuts the system if OVP pin voltage is lower than 100mV.

$$R_{OCP} = \frac{300mV}{I_{OCP}} \dots\dots\dots (16)$$

MOSFET Selection

To select a proper power MOSFET, a few key parameters are considered, such as the drain-source breakdown voltage (BV_{DSS}), on-resistance ($R_{DS(ON)}$) and package type (i.e., TO-220, TO-252, etc.). The MOSFET BV_{DSS} should be higher than the OVP voltage with 20% margin, since the MOSFET stress voltage when OVP is exactly the output voltage. The package of a power MOSFET greatly affects its thermal performance, a TO-252 (DPAK) package is recommended for typical applications. A low $R_{DS(ON)}$ MOSFET is beneficial for both system efficiency and the MOSFET thermal performance, but lower $R_{DS(ON)}$ usually means higher cost. Taking the peak inductor current and RMS current into account, a trade-off of system efficiency, thermal performance and cost is needed for selection.

Diode Selection

To maximize controller efficiency, the use of a Schottky diode is strongly recommended. In a boost controller, the average forward current of the rectifier diode I_F is equal to the output current I_{OUT} .

$$I_F = I_{OUT} \dots\dots\dots (17)$$

In practical application diode selection, the forward current rating should be at least 3 times the LED current.

The peak repetitive reverse voltage (V_{RRM}) of the diode should be higher than the OVP voltage with at least 20% margin, since the stress voltage when OVP is exactly the output voltage. A low-forward drop diode is preferable for its efficiency advantages and low-power dissipation of the diode.

PCB Layout Information

Layout Guide

The PCB layout is critical for the optimal performance of the boost-controller design. A good PCB layout is fundamental to achieve proper operation and high performance of the controller. EMI (electromagnetic interference) performance is especially dependent on the PCB layout.

So, the below important guidelines should be followed:

1. The traces of the power loops should be wide and short, and the power components should be placed close together to make the loop area as small as possible. There are two high-current power loops in the controller. One is the high-current input loop, and the other is the high-current output loop. The high-current input loop goes from the positive terminal of the CIN to the inductor, to the MOSFET, then to the current-sense resistor, and to the negative terminal of CIN. The high-current output loop goes from the positive terminal of the CIN to the inductor, to the diode, to the positive terminal of the COUT, reconnecting between the COUT and the CIN ground terminals.

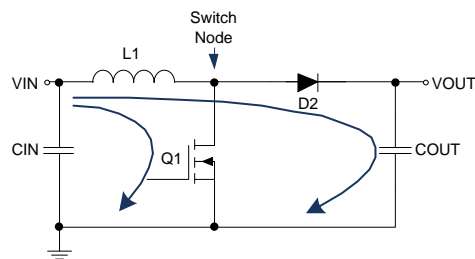

Figure 6. The Power Loops of a Boost Controller

2. A decoupling capacitor of the VIN pin is recommended and it should be placed as close as possible to the pin, to reduce the noise on the power source for the internal logic circuit.
3. To keep the gate signal clean, the gate driving trace should be placed away from the inductor, since the alternating magnetic field is the primary noise source in a switching controller
4. For the OVP resistor divider, the both resistors should be placed close to the IC, and the divider should be grounded close to the IC ground.
5. For the compensation capacitor, it should be placed as close as possible to the COMP pin.
6. Copper area of the power loop, especially around the switching node should be as big as possible for good thermal performance.

Design Tools (<https://www.diodes.com/design/tools/>)

- Evaluation Board User Guides
- Spice Models (PSpice Digital Simulation)
- Design Calculators

Ordering Information

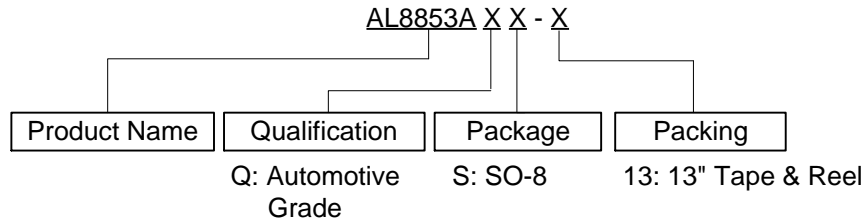

Part Number	Package Code	Package	Packing	
			Qty.	Carrier
AL8853AQS-13	S	SO-8	4000	13" Tape and Reel

Marking Information

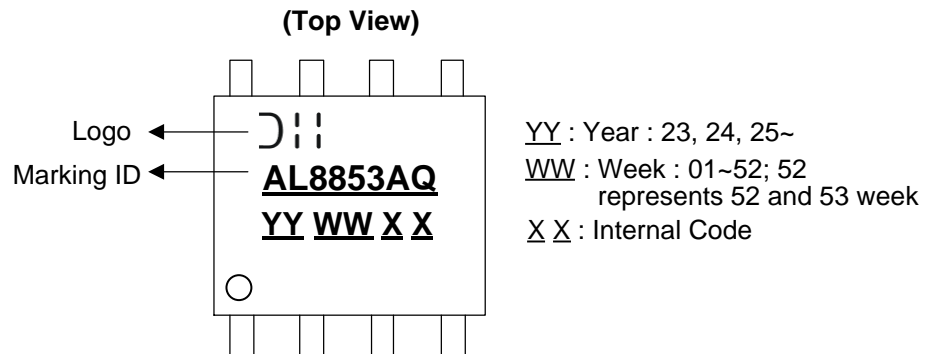

Package Outline Dimensions

Please see <http://www.diodes.com/package-outlines.html> for the latest version.

SO-8

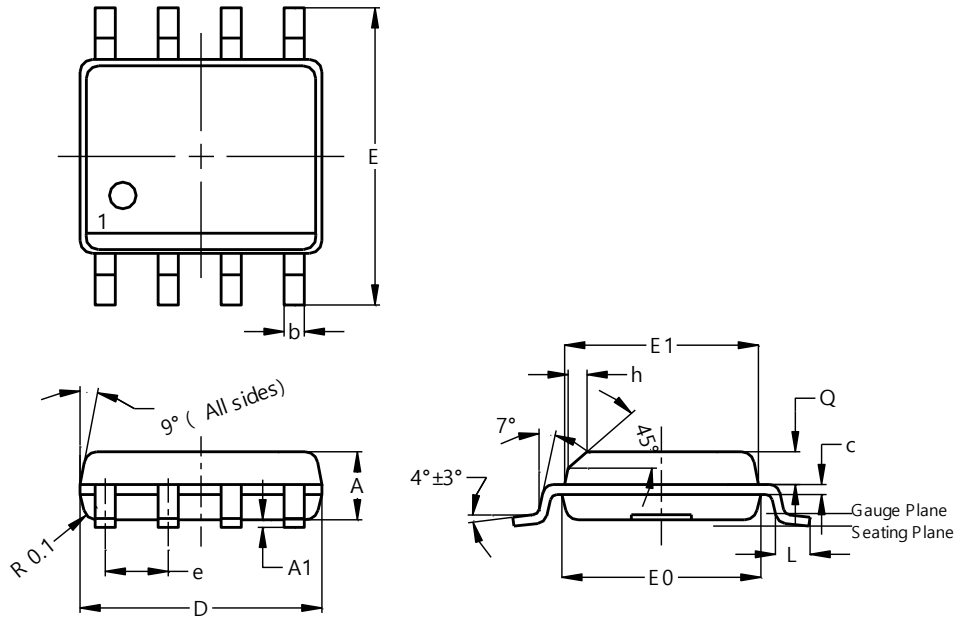

SO-8			
Dim	Min	Max	Typ
A	1.40	1.50	1.45
A1	0.10	0.20	0.15
b	0.30	0.50	0.40
c	0.15	0.25	0.20
D	4.85	4.95	4.90
E	5.90	6.10	6.00
E1	3.80	3.90	3.85
E0	3.85	3.95	3.90
e	--	--	1.27
h	-	--	0.35
L	0.62	0.82	0.72
Q	0.60	0.70	0.65
All Dimensions in mm			

Suggested Pad Layout

Please see <http://www.diodes.com/package-outlines.html> for the latest version.

SO-8

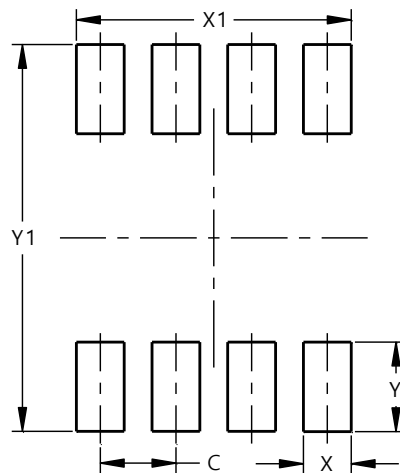

Dimensions	Value (in mm)
C	1.27
X	0.802
X1	4.612
Y	1.505
Y1	6.50

Mechanical Data

- Package: SO-8
- Surface-Mount Package
- Package Material: Molded Plastic, UL Flammability Rating 94V-0
- Moisture Sensitivity: Level 1 per JESD22-A113
- Terminals: Finish - Matte Tin Plated Leads, Solderable per M2003 JESD22-B1 (e3)
- Weight: 0.079 grams (Approximate)

IMPORTANT NOTICE

1. DIODES INCORPORATED (Diodes) AND ITS SUBSIDIARIES MAKE NO WARRANTY OF ANY KIND, EXPRESS OR IMPLIED, WITH REGARDS TO ANY INFORMATION CONTAINED IN THIS DOCUMENT, INCLUDING, BUT NOT LIMITED TO, THE IMPLIED WARRANTIES OF MERCHANTABILITY, FITNESS FOR A PARTICULAR PURPOSE OR NON-INFRINGEMENT OF THIRD PARTY INTELLECTUAL PROPERTY RIGHTS (AND THEIR EQUIVALENTS UNDER THE LAWS OF ANY JURISDICTION).
2. The Information contained herein is for informational purpose only and is provided only to illustrate the operation of Diodes' products described herein and application examples. Diodes does not assume any liability arising out of the application or use of this document or any product described herein. This document is intended for skilled and technically trained engineering customers and users who design with Diodes' products. Diodes' products may be used to facilitate safety-related applications; however, in all instances customers and users are responsible for (a) selecting the appropriate Diodes products for their applications, (b) evaluating the suitability of Diodes' products for their intended applications, (c) ensuring their applications, which incorporate Diodes' products, comply the applicable legal and regulatory requirements as well as safety and functional-safety related standards, and (d) ensuring they design with appropriate safeguards (including testing, validation, quality control techniques, redundancy, malfunction prevention, and appropriate treatment for aging degradation) to minimize the risks associated with their applications.
3. Diodes assumes no liability for any application-related information, support, assistance or feedback that may be provided by Diodes from time to time. Any customer or user of this document or products described herein will assume all risks and liabilities associated with such use, and will hold Diodes and all companies whose products are represented herein or on Diodes' websites, harmless against all damages and liabilities.
4. Products described herein may be covered by one or more United States, international or foreign patents and pending patent applications. Product names and markings noted herein may also be covered by one or more United States, international or foreign trademarks and trademark applications. Diodes does not convey any license under any of its intellectual property rights or the rights of any third parties (including third parties whose products and services may be described in this document or on Diodes' website) under this document.
5. Diodes' products are provided subject to Diodes' Standard Terms and Conditions of Sale (<https://www.diodes.com/about/company/terms-and-conditions/terms-and-conditions-of-sales/>) or other applicable terms. This document does not alter or expand the applicable warranties provided by Diodes. Diodes does not warrant or accept any liability whatsoever in respect of any products purchased through unauthorized sales channel.
6. Diodes' products and technology may not be used for or incorporated into any products or systems whose manufacture, use or sale is prohibited under any applicable laws and regulations. Should customers or users use Diodes' products in contravention of any applicable laws or regulations, or for any unintended or unauthorized application, customers and users will (a) be solely responsible for any damages, losses or penalties arising in connection therewith or as a result thereof, and (b) indemnify and hold Diodes and its representatives and agents harmless against any and all claims, damages, expenses, and attorney fees arising out of, directly or indirectly, any claim relating to any noncompliance with the applicable laws and regulations, as well as any unintended or unauthorized application.
7. While efforts have been made to ensure the information contained in this document is accurate, complete and current, it may contain technical inaccuracies, omissions and typographical errors. Diodes does not warrant that information contained in this document is error-free and Diodes is under no obligation to update or otherwise correct this information. Notwithstanding the foregoing, Diodes reserves the right to make modifications, enhancements, improvements, corrections or other changes without further notice to this document and any product described herein. This document is written in English but may be translated into multiple languages for reference. Only the English version of this document is the final and determinative format released by Diodes.
8. Any unauthorized copying, modification, distribution, transmission, display or other use of this document (or any portion hereof) is prohibited. Diodes assumes no responsibility for any losses incurred by the customers or users or any third parties arising from any such unauthorized use.
9. This Notice may be periodically updated with the most recent version available at <https://www.diodes.com/about/company/terms-and-conditions/important-notice>

The Diodes logo is a registered trademark of Diodes Incorporated in the United States and other countries.
All other trademarks are the property of their respective owners.
© 2023 Diodes Incorporated. All Rights Reserved.

www.diodes.com

Looking for pricing, stock, or lifecycle information?

Click below to explore more details on WIN SOURCE:

 [View AL8853AQS-13 on WIN SOURCE](#)

 [Diodes Incorporated](#) Information

Optimize Your Supply Chain with WIN SOURCE Solutions

-  Global Sourcing Solution
-  Obsolete Management
-  Cost Control Management
-  Shortage Management
-  Alternative Solution
-  Excess Inventory Management