



**THE DATASHEET OF
PI6C49CB02Q2WEX**



PI6C49CB02Q

Automotive AEC-Q100 Qualified Low Skew, 1-To-2 LVCMOS / LVTTTL Fanout Buffer

Features

- 2 LVCMOS / LVTTTL outputs
- LVCMOS / LVTTTL clock input accepts LVCMOS or LVTTTL input levels
- Maximum output frequency: 250MHz
- Output skew: 25ps (typical)
- Part-to-part skew: 250ps (typical)
- Small 8 lead SOIC package saves board space
- Full 3.3V, 2.5V operation modes
- AEC-Q100 Qualified
- Automotive Grade 2 temperature range (-40 to 105 °C)
- Automotive Grade 3 temperature range (-40 to 85 °C)
- Totally Lead-Free & Fully RoHS Compliant (Notes 1 & 2)
- Halogen and Antimony Free “Green” Device (Note 3)
- The PI6C49CB02Q is suitable for automotive applications requiring specific change control and is AEC-Q100 qualified, has a grade 2, -40 to 105 °C temperature rating and grade 3, -40 to 85 °C temperature rating, is PPAP capable, and is manufactured in IATF16949:2016 certified facilities.
- Package: 8-Pin, SOIC (W)

Description

The PI6C49CB02Q is an automotive qualified low skew, 1-to-2 LVCMOS/LVTTTL High Performance Fanout Buffer. The PI6C49CB02Q has a single ended clock input. The single ended clock input accepts LVCMOS or LVTTTL input levels. The PI6C49CB02Q features a pair of LVCMOS/LVTTTL outputs. Guaranteed output and part-to-part skew characteristics make the PI6C49CB02Q ideal for clock distribution applications demanding well defined performance and repeatability.

Block Diagram

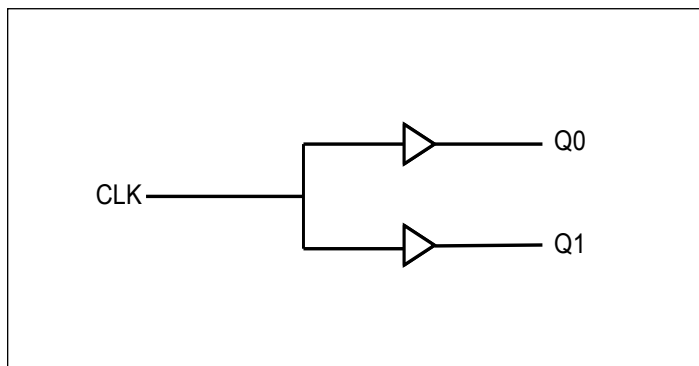

Pin Assignment

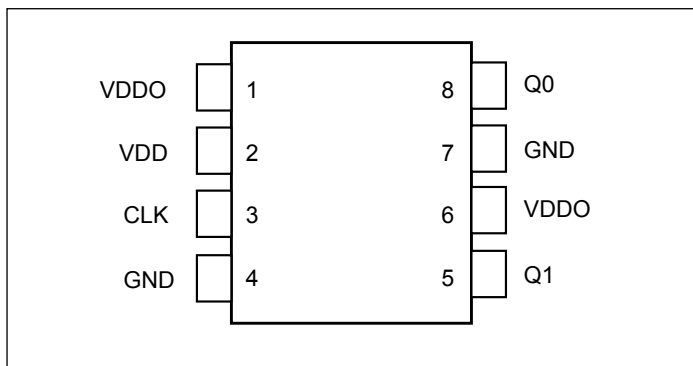

Notes:

1. No purposely added lead. Fully EU Directive 2002/95/EC (RoHS), 2011/65/EU (RoHS 2) & 2015/863/EU (RoHS 3) compliant.
2. See <https://www.diodes.com/quality/lead-free/> for more information about Diodes Incorporated’s definitions of Halogen- and Antimony-free, “Green” and Lead-free.
3. Halogen- and Antimony-free “Green” products are defined as those which contain <900ppm bromine, <900ppm chlorine (<1500ppm total Br + Cl) and <1000ppm antimony compounds.

Pin Descriptions

Pin#	Pin Name	Pin Type		Pin Description
1, 6	VDDO	Power		Output supply pins.
2	VDD	Power		Core supply pin.
3	CLK	Input	Pull-down	LVC MOS / LV TTL clock input.
4, 7	GND	Power		Power supply ground.
5	Q1	Output		Single clock output. LVC MOS / LV TTL interface levels.
8	Q0	Output		Single clock output. LVC MOS / LV TTL interface levels.

Note: *Pull-down* refer to internal input resistors, typical values in Pin Characteristics table.

Pin Characteristics

Symbol	Parameter	Test Conditions	Min.	Typ.	Max.	Units
C_N	Capacitance			4		pF
$R_{PULLDOWN}$	Input Pull-down Resistor			51		k Ω
R_{OUT}	Output Impedance		5	7	12	Ω

Maximum Ratings

(Above which useful life may be impaired. For user guidelines, not tested.)

Maximum Supply Voltage, VDD, VDDO	4.6V
Inputs, V _I	-0.5V to VDD+0.5V
Output, V _O	-0.5V to VDDO+0.5V
Storage Temperature	-65°C to 150°C
ESD Protection (HBM)	2000V
Junction Temperature	125°C (Max)

Note:

Stresses beyond those listed under Absolute Maximum Ratings may cause permanent damage to the device. These ratings are stress specifications only. Functional operation of product at these conditions or any conditions beyond those listed in the DC Characteristics or AC Characteristics

is not implied. Exposure to absolute maximum rating conditions for extended periods may affect product reliability.

Recommended Operation Conditions

Parameter	Min.	Typ.	Max.	Units
Ambient Operating Temperature (Automotive Grade 2)	-40		+105	°C
Ambient Operating Temperature (Automotive Grade 3)	-40		+85	°C
Power Supply Voltage (measured in respect to GND)	+2.375		+3.465	V

Power Supply DC Characteristics

Symbol	Parameter	Conditions	Min.	Typ.	Max.	Units
VDD	Core Supply Voltage	3.3V Operation	3.135	3.3	3.465	V
		2.5V Operation	2.375	2.5	2.625	
VDDO	Output Power Supply Voltage	3.3V Supply	3.135	3.3	3.465	V
		2.5V Supply	2.375	2.5	2.625	
IDD	Power Supply Current	T _A = -40°C to 85°C			5	mA
IDDO	Output Supply Current	Unloaded, 25 MHz, T _A = -40°C to 85°C			6.5	mA
IDD	Power Supply Current	T _A = -40°C to 105°C			5	mA
IDDO	Output Supply Current	Unloaded, 25 MHz, T _A = -40°C to 105°C			6.5	mA

Note: Parameters measured up to f_{max} unless otherwise noted.

LVCMOS / LVTTTL DC Characteristics, $T_A = -40^{\circ}\text{C}$ to 85°C

Symbol	Parameter	Conditions	Min.	Typ.	Max.	Units
V_{IH}	Input High Voltage	VDD = 3.3V	2		VDD+0.3	V
		VDD = 2.5V	1.7		VDD+0.3	
V_{IL}	Input Low Voltage	VDD = 3.3V	-0.3		0.8	V
		VDD = 2.5V	-0.3		0.8	
I_{IH}	Input High Current	VDD = $V_{IN} = 3.465\text{V}$			100	μA
		VDD = $V_{IN} = 2.625\text{V}$			80	
I_{IL}	Input Low Current	VDD = 3.465V, $V_{IN} = 0\text{V}$	-5			μA
		VDD = 2.625V, $V_{IN} = 0\text{V}$	-5			
V_{OH}	Output High Voltage	VDDO = 3.3V $I_{OH} = -100\mu\text{A}$	2.9			V
		VDDO = 2.5V $I_{OH} = -100\mu\text{A}$	2.2			V
V_{OL}	Output Low Voltage	VDDO = 3.3V $I_{OL} = 100\mu\text{A}$			0.2	V
		VDDO = 2.5V $I_{OL} = 100\mu\text{A}$			0.2	V

LVCMOS / LVTTTL DC Characteristics, $T_A = -40^{\circ}\text{C}$ to 105°C

Symbol	Parameter	Conditions	Min.	Typ.	Max.	Units
V_{IH}	Input High Voltage	VDD = 3.3V	2		VDD+0.3	V
		VDD = 2.5V	1.7		VDD+0.3	
V_{IL}	Input Low Voltage	VDD = 3.3V	-0.3		0.8	V
		VDD = 2.5V	-0.3		0.8	
I_{IH}	Input High Current	VDD = $V_{IN} = 3.465\text{V}$			100	μA
		VDD = $V_{IN} = 2.625\text{V}$			80	
I_{IL}	Input Low Current	VDD = 3.465V, $V_{IN} = 0\text{V}$	-5			μA
		VDD = 2.625V, $V_{IN} = 0\text{V}$	-5			
V_{OH}	Output High Voltage	VDDO = 3.3V $I_{OH} = -100\mu\text{A}$	2.9			V
		VDDO = 2.5V $I_{OH} = -100\mu\text{A}$	2.2			V
V_{OL}	Output Low Voltage	VDDO = 3.3V $I_{OL} = 100\mu\text{A}$			0.2	V
		VDDO = 2.5V $I_{OL} = 100\mu\text{A}$			0.2	V

AC Characteristics, VDD = 3.3V ± 5%, T_A = -40°C to 85°C

Symbol	Parameter	Conditions	Min.	Typ.	Max.	Units
f _{MAX}	Output Frequency	VDDO = 3.3V	4		250	MHz
		VDDO = 2.5V	4		250	
t _{pLH}	Propagation Delay, Low-to-High ⁽¹⁾	VDDO = 3.3V, f ≤ 250MHz	1.4		2.2	ns
		VDDO = 2.5V, f ≤ 250MHz	1.5		3.0	
t _{sk(o)}	Output Skew ⁽²⁾			25	80	ps
t _{sk(pp)}	Part-to-Part Skew ⁽³⁾			250	800	ps
t _R	Output Rise Time ⁽⁴⁾	VDDO = 3.3V	100	300	400	ps
		VDDO = 2.5V	100	350	500	
t _F	Output Fall Time ⁽⁴⁾	VDDO = 3.3V	100	300	400	ps
		VDDO = 2.5V	100	350	500	
odc	Output Duty Cycle ⁽⁵⁾	f ≤ 133MHz	48		52	%
		133MHz < f ≤ 200MHz	47		53	%
		200MHz < f ≤ 250MHz	47		53	%
t _{jit}	Additive RMS Jitter	156.25MHz (@12kHz to 20MHz)		0.1		ps
		125MHz (@12kHz to 20MHz)		0.07		ps

Note:

Parameters measured at f_{MAX} unless otherwise noted.

1. Measured from VDD /2 of the input to VDDO /2 of the output.

2. Defined as skew between outputs at the same supply voltage and with equal load conditions. Measured at VDDO /2.

3. Defined as skew between outputs on different devices operating at the same supply voltages and with equal load conditions. Using the same type of inputs on each device, the outputs are measured at VDDO /2.

4. Defined from 20% to 80%

5. Measured at VDDO /2

AC Characteristics, $VDD = 3.3V \pm 5\%$, $T_A = -40^{\circ}C$ to $105^{\circ}C$

Symbol	Parameter	Conditions	Min.	Typ.	Max.	Units
f_{MAX}	Output Frequency	VDDO = 3.3V	4		250	MHz
		VDDO = 2.5V	4		250	
t_{pLH}	Propagation Delay, Low-to-High ⁽¹⁾	VDDO = 3.3V, $f \leq 250MHz$	1.4		2.2	ns
		VDDO = 2.5V, $f \leq 250MHz$	1.5		3.0	
$tsk(o)$	Output Skew ⁽²⁾			25	80	ps
$tsk(pp)$	Part-to-Part Skew ⁽³⁾			250	800	ps
t_R	Output Rise Time ⁽⁴⁾	VDDO = 3.3V	100	300	400	ps
		VDDO = 2.5V	100	350	500	
t_F	Output Fall Time ⁽⁴⁾	VDDO = 3.3V	100	300	400	ps
		VDDO = 2.5V	100	350	500	
odc	Output Duty Cycle ⁽⁵⁾	$f \leq 133MHz$	48		52	%
		$133MHz < f \leq 200MHz$	47		53	%
		$200MHz < f \leq 250MHz$	47		53	%
t_{jit}	Additive RMS Jitter	156.25MHz (@12kHz to 20MHz)		0.1		ps
		125MHz (@12kHz to 20MHz)		0.07		ps

Note:

 Parameters measured at f_{MAX} unless otherwise noted.

1. Measured from $VDD / 2$ of the input to $VDDO / 2$ of the output.
2. Defined as skew between outputs at the same supply voltage and with equal load conditions. Measured at $VDDO / 2$.
3. Defined as skew between outputs on different devices operating at the same supply voltages and with equal load conditions. Using the same type of inputs on each device, the outputs are measured at $VDDO / 2$.
4. Defined from 20% to 80%
5. Measured at $VDDO / 2$

AC Characteristics, $V_{DD} = 2.5V \pm 5\%$, $T_A = -40^\circ C$ to $85^\circ C$

Symbol	Parameter	Conditions	Min.	Typ.	Max.	Units
f_{MAX}	Output Frequency	$V_{DDO} = 2.5V$	4		250	MHz
t_{pLH}	Propagation Delay, Low-to-High ⁽¹⁾	$V_{DDO} = 2.5V, f \leq 250MHz$	1.5		2.8	ns
$tsk(o)$	Output Skew ⁽²⁾			25	75	ps
$tsk(pp)$	Part-to-Part Skew ⁽³⁾			250	800	ps
t_R	Output Rise Time ⁽⁴⁾	$V_{DDO} = 2.5V$	100	350	500	ps
t_F	Output Fall Time ⁽⁴⁾	$V_{DDO} = 2.5V$	100	350	500	ps
odc	Output Duty Cycle ⁽⁵⁾	$f \leq 133MHz$	48		52	%
		$133MHz < f \leq 200MHz$	47		53	%
		$200MHz < f \leq 250MHz$	42		58	%
t_{jit}	Additive RMS Jitter	156.25MHz (@12kHz to 20MHz)		0.1		ps
		125MHz (@12kHz to 20MHz)		0.07		ps

Note:

Parameters measured at f_{MAX} unless otherwise noted.

1. Measured from $V_{DD} / 2$ of the input to $V_{DDO} / 2$ of the output.
2. Defined as skew between outputs at the same supply voltage and with equal load conditions. Measured at $V_{DDO} / 2$.
3. Defined as skew between outputs on different devices operating at the same supply voltages and with equal load conditions. Using the same type of inputs on each device, the outputs are measured at $V_{DDO} / 2$.
4. Defined from 20% to 80%
5. Measured at $V_{DDO} / 2$

AC Test Circuit Load

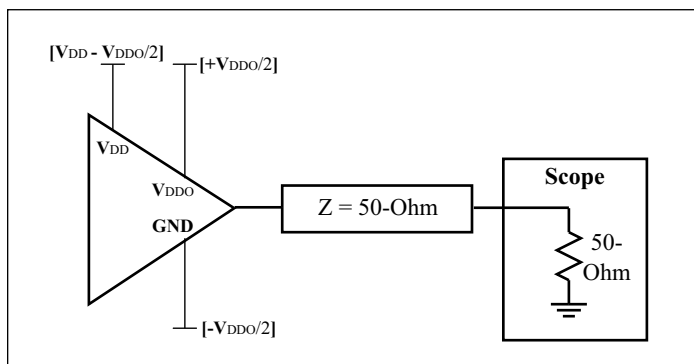

AC Characteristics, VDD = 2.5V ± 5%, T_A = -40°C to 105°C

Symbol	Parameter	Conditions	Min.	Typ.	Max.	Units
f _{MAX}	Output Frequency	VDDO = 2.5V	4		250	MHz
tp _{LH}	Propagation Delay, Low-to-High ⁽¹⁾	VDDO = 2.5V, f ≤ 250MHz	1.5		2.8	ns
tsk(o)	Output Skew ⁽²⁾			25	75	ps
tsk(pp)	Part-to-Part Skew ⁽³⁾			250	800	ps
t _R	Output Rise Time ⁽⁴⁾	VDDO = 2.5V	100	350	500	ps
t _F	Output Fall Time ⁽⁴⁾	VDDO = 2.5V	100	350	500	ps
odc	Output Duty Cycle ⁽⁵⁾	f ≤ 133MHz	48		52	%
		133MHz < f ≤ 200MHz	47		53	%
		200MHz < f ≤ 250MHz	42		58	%
t _{jit}	Additive RMS Jitter	156.25MHz (@12kHz to 20MHz)		0.1		ps
		125MHz (@12kHz to 20MHz)		0.07		ps

- Note:**
Parameters measured at f_{MAX} unless otherwise noted.
1. Measured from VDD / 2 of the input to VDDO / 2 of the output.
 2. Defined as skew between outputs at the same supply voltage and with equal load conditions. Measured at VDDO / 2.
 3. Defined as skew between outputs on different devices operating at the same supply voltages and with equal load conditions. Using the same type of inputs on each device, the outputs are measured at VDDO / 2.
 4. Defined from 20% to 80%
 5. Measured at VDDO / 2

Part Marking

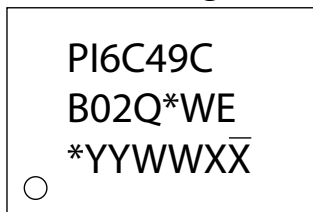

- *: Die Rev (2 or 3)
- YY: Year
- WW: Workweek
- 1st X: Assembly Site Code
- 2nd X: Wafer Site Code

PI6C49CB02Q

Packaging Mechanical: 8-SOIC (W)

SYMBOLS	MIN.	NOM.	MAX.
A	—	—	1.75
A1	0.10	—	0.25
A2	1.25	—	—
b	0.31	—	0.51
c	0.10	—	0.25
D	4.80	4.90	5.00
E	5.80	6.00	6.20
E1	3.80	3.90	4.00
e	1.27 BSC		
L	0.40	—	1.27
h	0.25	—	0.50
θ°	0	—	8

UNIT : mm

NOTE :
 1. ALL DIMENSIONS ARE IN mm. ANGLES IN DEGREES
 2. DIMENSIONS EXCLUDE BURRS, MOLD FLASH OR PROTRUSIONS
 3. REFER JEDEC MS-012

PERICOM
Enabling Serial Connectivity

DATE: 02/21/14

DESCRIPTION: 8-Pin, 150mil-Wide, SOIC

PACKAGE CODE: W (W8)

DOCUMENT CONTROL #: PD-1001

REVISION: G

15-0103

For latest package info.

please check: <http://www.diodes.com/design/support/packaging/pericom-packaging/packaging-mechanicals-and-thermal-characteristics/>

Ordering Information

Ordering Code	Package Code	Operating Temperature	Package Description
PI6C49CB02Q2WEX	W	-40 to 105°C	8-pin, 150mil-Wide (SOIC)
PI6C49CB02Q3WEX	W	-40 to 85°C	8-pin, 150mil-Wide (SOIC)

Notes:

1. No purposely added lead. Fully EU Directive 2002/95/EC (RoHS), 2011/65/EU (RoHS 2) & 2015/863/EU (RoHS 3) compliant.
2. See <https://www.diodes.com/quality/lead-free/> for more information about Diodes Incorporated's definitions of Halogen- and Antimony-free, "Green" and Lead-free.
3. Halogen- and Antimony-free "Green" products are defined as those which contain <900ppm bromine, <900ppm chlorine (<1500ppm total Br + Cl) and <1000ppm antimony compounds.
4. Q = Automotive Compliant
5. 2 and 3 = AEC-Q100 Grade Level
6. E = Pb-free and Green
7. X suffix = Tape/Reel

IMPORTANT NOTICE

DIODES INCORPORATED MAKES NO WARRANTY OF ANY KIND, EXPRESS OR IMPLIED, WITH REGARDS TO THIS DOCUMENT, INCLUDING, BUT NOT LIMITED TO, THE IMPLIED WARRANTIES OF MERCHANTABILITY AND FITNESS FOR A PARTICULAR PURPOSE (AND THEIR EQUIVALENTS UNDER THE LAWS OF ANY JURISDICTION).

Diodes Incorporated and its subsidiaries reserve the right to make modifications, enhancements, improvements, corrections or other changes without further notice to this document and any product described herein. Diodes Incorporated does not assume any liability arising out of the application or use of this document or any product described herein; neither does Diodes Incorporated convey any license under its patent or trademark rights, nor the rights of others. Any Customer or user of this document or products described herein in such applications shall assume all risks of such use and will agree to hold Diodes Incorporated and all the companies whose products are represented on Diodes Incorporated website, harmless against all damages.

Diodes Incorporated does not warrant or accept any liability whatsoever in respect of any products purchased through unauthorized sales channel.

Should Customers purchase or use Diodes Incorporated products for any unintended or unauthorized application, Customers shall indemnify and hold Diodes Incorporated and its representatives harmless against all claims, damages, expenses, and attorney fees arising out of, directly or indirectly, any claim of personal injury or death associated with such unintended or unauthorized application.

Products described herein may be covered by one or more United States, international or foreign patents pending. Product names and markings noted herein may also be covered by one or more United States, international or foreign trademarks.

This document is written in English but may be translated into multiple languages for reference. Only the English version of this document is the final and definitive format released by Diodes Incorporated.

LIFE SUPPORT

Diodes Incorporated products are specifically not authorized for use as critical components in life support devices or systems without the express written approval of the Chief Executive Officer of Diodes Incorporated. As used herein:

A. Life support devices or systems are devices or systems which:

1. are intended to implant into the body, or

2. support or sustain life and whose failure to perform when properly used in accordance with instructions for use provided in the labeling can be reasonably expected to result in significant injury to the user.

B. A critical component is any component in a life support device or system whose failure to perform can be reasonably expected to cause the failure of the life support device or to affect its safety or effectiveness.

Customers represent that they have all necessary expertise in the safety and regulatory ramifications of their life support devices or systems, and acknowledge and agree that they are solely responsible for all legal, regulatory and safety-related requirements concerning their products and any use of Diodes Incorporated products in such safety-critical, life support devices or systems, notwithstanding any devices- or systems-related information or support that may be provided by Diodes Incorporated. Further, Customers must fully indemnify Diodes Incorporated and its representatives against any damages arising out of the use of Diodes Incorporated products in such safety-critical, life support devices or systems.

Copyright © 2016, Diodes Incorporated

www.diodes.com

Looking for pricing, stock, or lifecycle information?

Click below to explore more details on WIN SOURCE:

 [View PI6C49CB02Q2WEX on WIN SOURCE](#)

 [Diodes Incorporated](#) Information

Optimize Your Supply Chain with WIN SOURCE Solutions

-  Global Sourcing Solution
-  Obsolete Management
-  Cost Control Management
-  Shortage Management
-  Alternative Solution
-  Excess Inventory Management