



**THE DATASHEET OF
ADUM1253ASA+T**



Ultra-Low-Power, I2C Isolator with Unidirectional SCL, Extended VDD, Idle-Bus Hot-Swap, and Low VOL

ADuM1253

General Description

The ADuM1253 offers two open-drain channels, one unidirectional and one bidirectional for applications, such as I²C, that require data to be transmitted in both directions on the same line but have a unidirectional clock. To prevent latch-up action, side 1 outputs comprise special buffers that regulate the logic-low voltage at 0.64V, and the input logic-low threshold is at least 50mV lower than the output logic-low voltage. Side 2 features conventional buffers that do not regulate logic-low output voltage.

The ADuM1253 features independent 1.71V to 5.5V supplies on both side 1 and side 2 of the isolator. The device operates up to 2MHz. The ultra-low standby current of 21µA per side is ideal for battery-operated systems.

The ADuM1253 provides a disturbance-free bus connection for hot-plug connections on side 2 by first precharging the bus pins and then monitoring the bus state for either an idle bus or detection of a I²C stop condition before connecting side 1 and side 2.

The ADuM1253 is available in both an 8-pin narrow- and wide-body SOIC package, and in an 8-pin MSOP package. The device is rated for operation at ambient temperatures of -40°C to +125°C.

Key Applications

- Isolated I²C/SMBus Interface
- Battery Management Systems
- Power Over Ethernet (PoE)
- Motor Control Systems

Simplified Application Diagram

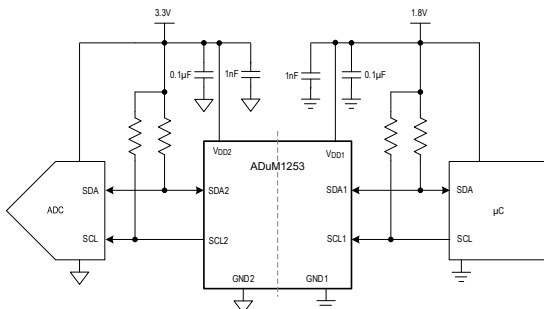

Benefits and Features

- Low $V_{OL(MAX)}$ for Greater I²C Device Compatibility
 - Side 1: 0.69V
 - Side 2: 0.4V
- Ultra-Low-Power Consumption for Longer Battery Life
 - 142µA (typ) per Channel at 400kHz
- Wide Independent V_{DD1}/V_{DD2} Supply Range Supports More Logic Voltage Levels and Allows Level Shifting
 - 1.71V to 5.5V for Both Sides
- Hot-Swappable Side 2 I/O Prevents Data Corruption
 - Initial Side 2 Connection Occurs at Bus Idle or Stop States
- Bidirectional I²C Transfer up to 2MHz SCL
- Strong Current Sinking Enables Lower $R_{PULL-UP}$ Values for Faster Bus Speeds
 - Side 1: 5mA
 - Side 2: 50mA
- Robust Galvanic Isolation of Digital Signals
 - Continuously Withstands (V_{IOWM})
 - 8-MSOP: 300 V_{RMS}
 - 8-Narrow SOIC: 445 V_{RMS}
 - 8-Wide SOIC: 848 V_{RMS}
 - Withstands ±10kV Surge per IEC 61000-4-5
 - 3 Package with Creepage and Clearance
 - 8-MSOP: 3mm
 - 8-Narrow SOIC: 4mm
 - 8-Wide SOIC: 8mm
- Safety and Regulatory Approvals (Pending)
 - IEC 60747-17 (Pending)
 - Reinforced V_{IORM} Narrow SOIC: 630V_{PEAK}
 - Reinforced V_{IORM} Wide SOIC: 1200V_{PEAK}
 - UL 1577 (Pending)
 - 8-Narrow SOIC: 3000 V_{RMS} for 1min
 - 8-Wide SOIC: 5000 V_{RMS} for 1min
 - IEC/EN/CSA 62368-1 (Pending)
 - IEC/EN/CSA 61010-1 (Pending)
 - CAN/CSA-C22.2 No. 14–18 (Pending)

[Ordering Information](#) appears at end of data sheet.

Ultra-Low-Power, I2C Isolator with Unidirectional SCL, Extended VDD, Idle-Bus Hot-Swap, and Low VOL

ADuM1253

Absolute Maximum Ratings

V _{DD1} to GND1.....	-0.3V to +6.0V	8 MSOP (Derate 3.09mW/°C above +70°C).....	+247mW
V _{DD2} to GND2.....	-0.3V to +6.0V	8 NSOIC (Derate 5.49mW/°C above +70°C).....	+440mW
SDA1, SCL1 to GND1.....	-0.3V to +6.0V	8 WSOIC (Derate 5.88mW/°C above +70°C).....	+471mW
SDA2, SCL2 to GND2.....	-0.3V to +6.0V	Temperature	
Short-Circuit Continuous Current		Operating Temperature Range.....	-40°C to +125°C
SDA1, SCL1 to V _{DD1}	20mA	Junction Temperature.....	+150°C
SDA2, SCL2 to V _{DD2}	100mA	Storage Temperature.....	-65°C to +150°C
Continuous Power Dissipation		Lead Temperature (Soldering, 10s).....	+300°C
		Soldering Temperature (reflow).....	+260°C

Stresses beyond those listed under "Absolute Maximum Ratings" may cause permanent damage to the device. These are stress ratings only, and functional operation of the device at these or any other conditions beyond those indicated in the operational sections of the specifications is not implied. Exposure to absolute maximum rating conditions for extended periods may affect device reliability.

Package Information

8 MSOP

Outline Number	21-0036
Land Pattern Number	90-0092
Junction-to-Ambient Thermal Resistance (θ_{JA})	324°C/W
Junction-to-Case Top Thermal Resistance ($\theta_{JC(TOP)}$)	72°C/W
Junction-to-Board Thermal Resistance (θ_{JB})	153.5°C/W
Junction-to-Case Top Thermal Characterization Parameter (ψ_{JT})	4°C/W
Junction-to-Board Thermal Characterization Parameter (ψ_{JB})	152°C/W
Moisture Sensitivity Level	3

8 Narrow SOIC

Outline Number	21-0041
Land Pattern Number	90-0096
Junction-to-Ambient Thermal Resistance (θ_{JA})	182°C/W
Junction-to-Case Top Thermal Resistance ($\theta_{JC(TOP)}$)	50°C/W
Junction-to-Board Thermal Resistance (θ_{JB})	63.6°C/W
Junction-to-Case Top Thermal Characterization Parameter (ψ_{JT})	8°C/W
Junction-to-Board Thermal Characterization Parameter (ψ_{JB})	60°C/W
Moisture Sensitivity Level	3

8 Wide SOIC

Outline Number	21-100415
Land Pattern Number	90-100146
Junction-to-Ambient Thermal Resistance (θ_{JA})	170°C/W
Junction-to-Case Top Thermal Resistance ($\theta_{JC(TOP)}$)	64°C/W
Junction-to-Board Thermal Resistance (θ_{JB})	60.9°C/W
Junction-to-Case Top Thermal Characterization Parameter (ψ_{JT})	12°C/W
Junction-to-Board Thermal Characterization Parameter (ψ_{JB})	62°C/W
Moisture Sensitivity Level	3

For the latest package outline information and land patterns (footprints), go to www.analog.com/en/design-center/packaging-quality-symbols-footprints/package-index.html. Note that a “+”, “#”, or “-” in the package code indicates RoHS status only. Package drawings may show a different suffix character, but the drawing pertains to the package regardless of RoHS status.

Package thermal resistances were obtained using the method described in JEDEC specification JESD51-7, using a four-layer board. For detailed information on package thermal considerations, refer to www.analog.com/en/technical-articles/thermal-characterization-of-ic-packages.

Electrical Characteristics

($V_{DD1} - V_{GND1} = +1.71V$ to $+5.5V$, $V_{DD2} - V_{GND2} = +1.71V$ to $+5.5V$, $C_L = 20pF$, $T_A = -40^\circ C$ to $+125^\circ C$, unless otherwise noted ([Note 1](#), [Note 2](#)). Typical values are at $V_{DD1} - V_{GND1} = 3.3V$, $V_{DD2} - V_{GND2} = 3.3V$, $T_A = +25^\circ C$, unless otherwise noted.)

PARAMETER	SYMBOL	CONDITIONS	MIN	TYP	MAX	UNITS
POWER SUPPLY						
Supply Voltage	V_{DD1}	Relative to GND1	1.71		5.5	V
	V_{DD2}	Relative to GND2	1.71		5.5	
Undervoltage-Lockout Threshold Side _u	$V_{UVLO_}$	$V_{DD_}$ rising	1.48	1.6	1.65	V
Undervoltage-Lockout Threshold Hysteresis	V_{UVLO_HYST}	(Note 5)		30		mV
SUPPLY CURRENT (Note 2 , Note 3)						
Supply Current—Side 1	I_{DD1}	$V_{DD1} = V_{DD2} = 1.8V - 5V$	SDA1/SCL1 = V_{DD1}	20	34	μA
			SDA1/SCL1 = 400kHz square wave	200	250	
			SDA1/SCL1 = 1MHz square wave	270	340	
Supply Current—Side 2	I_{DD2}	$V_{DD1} = V_{DD2} = 1.8V - 5V$	SDA2/SCL2 = V_{DD2}	21	35	μA
			SDA2/SCL2 = GND2	49	70	
			SDA2/SCL2 = 400kHz square wave	84	110	
			SDA2/SCL2 = 1MHz square wave	146	180	
LOGIC INPUTS AND OUTPUTS						
Input High Voltage, SDA1/SCL1	V_{IH1}	Relative to GND1	0.52	0.56	0.62	V

($V_{DD1} - V_{GND1} = +1.71V$ to $+5.5V$, $V_{DD2} - V_{GND2} = +1.71V$ to $+5.5V$, $C_L = 20pF$, $T_A = -40^\circ C$ to $+125^\circ C$, unless otherwise noted ([Note 1](#), [Note 2](#)). Typical values are at $V_{DD1} - V_{GND1} = 3.3V$, $V_{DD2} - V_{GND2} = 3.3V$, $T_A = +25^\circ C$, unless otherwise noted.)

PARAMETER	SYMBOL	CONDITIONS		MIN	TYP	MAX	UNITS
Input Low Voltage, SDA1/SCL1	V_{IL1}	Relative to GND1		0.47	0.51	0.56	V
Input Hysteresis, Side 1	V_{HYS1}	$V_{IH1} - V_{IL1}$	(Note 5)	50			mV
Output Low Voltage, SDA1	V_{OL1}	Relative to GND1	$I = 0.1mA - 5mA$ sink	0.59	0.64	0.69	V
Low-level Output Voltage to High-Level Input Voltage Threshold Difference, SDA1	$\Delta V_{O/IT}$	SDA1, $V_{OL} - V_{IH}$	(Note 4)	45			mV
Input High Voltage, SDA2	V_{IH2}	SDA2 to GND2		$0.52 \times V_{DD2}$	$0.45 \times V_{DD2}$		V
Input Low Voltage, SDA2	V_{IL2}	SDA2 to GND2			$0.38 \times V_{DD2}$	$0.3 \times V_{DD2}$	V
Input Hysteresis, Side 2	V_{HYS2}	$V_{IH2} - V_{IL2}$			$0.07 \times V_{DD2}$		V
Output Low Voltage, Side 2	V_{OL2}	SDA2/SCL2 to GND2	$I = 50mA$ sink			0.4	V
Static Output Loading	I_{SDA1}	Side 1		0.1		5	mA
	$I_{SDA2/SCL2}$	Side 2		0.1		50	
Leakage Current	I_L	Device unpowered	SDA1/SCL1 = 5.5V, $V_{DD1} = 0V$	-10		+10	μA
			SDA2/SCL2 = 5.5V, $V_{DD2} = 0V$	-10		+10	
		Device powered	SDA1 = SCL1 = $V_{DD1} = 5.5V$	-10		+10	
		Device powered and not in precharge	SDA2 = SCL2 = $V_{DD2} = 5.5V$	-10		+10	
Input Capacitance	C_{IN}	$f = 1MHz$	(Note 5)	5			pF
ESD Protection (Note 5)							
ESD		Human Body Model	V_{DD1} to same side pins, V_{DD2} to same side pins	± 8			kV
			SDA1/SCL1 to GND1	± 17			
			SDA2/SCL2 to GND2	± 17			
		IEC 61000-4-2 contact discharge	SDA1/SCL1 to GND1 unpowered	± 8			
			SDA2/SCL2 to GND2 unpowered	± 8			
		IEC 61000-4-2 contact discharge (GND2 to GND1)	8 Wide SOIC	± 5			
			8 Narrow SOIC	± 5			
		8 MSOP	± 4				

Dynamic Characteristics

($V_{DD1} - V_{GND1} = 1.71V$ to $5.5V$, $V_{DD2} - V_{GND2} = 1.71V$ to $5.5V$, $C_L = 20pF$, $T_A = -40^\circ C$ to $+125^\circ C$, unless otherwise noted. ([Note 5](#))
Typical values are at $V_{DD1} - V_{GND1} = 3.3V$, $V_{DD2} - V_{GND2} = 3.3V$, $T_A = +25^\circ C$, unless otherwise noted.)

PARAMETER	SYMBOL	CONDITIONS	MIN	TYP	MAX	UNITS		
Common-Mode Transient Immunity	CMTI	(Note 6)	200			kV/ μs		
Maximum Data Rate	DR _{MAX}		2			MHz		
Fall Time	t_{F1}	SDA1 = $0.7 \times V_{DD1}$ to $0.3 \times V_{DD1}$	$4.5V \leq V_{DD1} \leq 5.5V$, $C_{L1} = 40pF$, $R_1 = 1.6k\Omega$	8.8	20.3	36.1	ns	
			$3.0V \leq V_{DD1} \leq 3.6V$, $C_{L1} = 40pF$, $R_1 = 1k\Omega$	6.1	13.7	24.1		
			$2.25V \leq V_{DD1} \leq 2.75V$, $C_{L1} = 40pF$, $R_1 = 810\Omega$	4.6	10.4	18.5		
		SDA1 = $0.7 \times V_{DD1}$ to $0.75V$	$1.71V \leq V_{DD1} \leq 1.89V$, $C_{L1} = 40pF$, $R_1 = 470\Omega$	2.4	4.7	11.5		
		SDA1 = $0.9 \times V_{DD1}$ to $0.9V$	$4.5V \leq V_{DD1} \leq 5.5V$, $C_{L1} = 40pF$, $R_1 = 1.6k\Omega$	15.4	34.7	64.7		
			$3.0V \leq V_{DD1} \leq 3.6V$, $C_{L1} = 40pF$, $R_1 = 1k\Omega$	9.1	19.7	35.9		
			$2.25V \leq V_{DD1} \leq 2.75V$, $C_{L1} = 40pF$, $R_1 = 810\Omega$	6.0	12.2	23.3		
			$1.71V \leq V_{DD1} \leq 1.89V$, $C_{L1} = 40pF$, $R_1 = 470\Omega$	3.8	6.5	11.1		
			t_{F2}	SDA2/SCL2 = $0.7 \times V_{DD2}$ to $0.3 \times V_{DD2}$	$4.5V \leq V_{DD2} \leq 5.5V$, $C_{L2} = 400pF$, $R_2 = 180\Omega$	11.8		18.6
		$3.0V \leq V_{DD2} \leq 3.6V$, $C_{L2} = 400pF$, $R_2 = 120\Omega$			9.0	13.8		21.0
		$2.25V \leq V_{DD2} \leq 2.75V$, $C_{L2} = 400pF$, $R_2 = 91\Omega$			7.6	11.6		17.0
		$1.71V \leq V_{DD2} \leq 1.89V$, $C_{L2} = 400pF$, $R_2 = 81\Omega$			6.5	9.5		13.4
	SDA2/SCL2 = $0.9 \times V_{DD2}$ to $0.4V$	$4.5V \leq V_{DD2} \leq 5.5V$, $C_{L2} = 400pF$, $R_2 = 180\Omega$		25.7	41.0	63.0		
		$3.0V \leq V_{DD2} \leq 3.6V$, $C_{L2} = 400pF$, $R_2 = 120\Omega$		19.0	29.0	44.4		
		$2.25V \leq V_{DD2} \leq 2.75V$, $C_{L2} = 400pF$, $R_2 = 91\Omega$		15.5	24.0	36.3		

($V_{DD1} - V_{GND1} = 1.71V$ to $5.5V$, $V_{DD2} - V_{GND2} = 1.71V$ to $5.5V$, $C_L = 20pF$, $T_A = -40^\circ C$ to $+125^\circ C$, unless otherwise noted. (Note 5)
Typical values are at $V_{DD1} - V_{GND1} = 3.3V$, $V_{DD2} - V_{GND2} = 3.3V$, $T_A = +25^\circ C$, unless otherwise noted.)

PARAMETER	SYMBOL	CONDITIONS	MIN	TYP	MAX	UNITS	
		$1.71V \leq V_{DD2} \leq 1.89V$, $C_{L2} = 400pF$, $R_2 = 81\Omega$	12.4	18.0	26.1		
Propagation Delay	t_{PLH12}	$4.5V \leq V_{DD_} \leq 5.5V$, $C_{L1} = 20pF$, $R_1 = 1.6k\Omega$, $C_{L2} = 20pF$, $R_2 = 180\Omega$		37.6	50.0	ns	
		$3.0V \leq V_{DD_} \leq 3.6V$, $C_{L1} = 20pF$, $R_1 = 1k\Omega$, $C_{L2} = 20pF$, $R_2 = 120\Omega$		35.9	48.0		
		$2.25V \leq V_{DD_} \leq 2.75V$, $C_{L1} = 20pF$, $R_1 = 810\Omega$, $C_{L2} = 20pF$, $R_2 = 91\Omega$		35.2	47.0		
		$1.71V \leq V_{DD_} \leq 1.89V$, $C_{L1} = 20pF$, $R_1 = 470\Omega$, $C_{L2} = 20pF$, $R_2 = 81\Omega$		36.5	51.6		
	t_{PHL12}	$4.5V \leq V_{DD_} \leq 5.5V$, $C_{L1} = 20pF$, $R_1 = 1.6k\Omega$, $C_{L2} = 20pF$, $R_2 = 180\Omega$		93.7	133.3		
		$3.0V \leq V_{DD1_} \leq 3.6V$, $C_{L1} = 20pF$, $R_1 = 1k\Omega$, $C_{L2} = 20pF$, $R_2 = 120\Omega$		84.2	116.4		
		$2.25V \leq V_{DD_} \leq 2.75V$, $C_{L1} = 10pF$, $R_1 = 810\Omega$, $C_{L2} = 20pF$, $R_2 = 91\Omega$		78.8	107.3		
		$1.71V \leq V_{DD_} \leq 1.89V$, $C_{L1} = 20pF$, $R_1 = 470\Omega$, $C_{L2} = 20pF$, $R_2 = 81\Omega$		75.6	100.1		
	t_{PLH21}	$4.5V \leq V_{DD_} \leq 5.5V$, $C_{L1} = 20pF$, $R_1 = 1.6k\Omega$, $C_{L2} = 20pF$, $R_2 = 180\Omega$			86.7		95.8
		$3.0V \leq V_{DD_} \leq 3.6V$, $C_{L1} = 20pF$, $R_1 = 1k\Omega$, $C_{L2} = 20pF$, $R_2 = 120\Omega$			67.3		76.3
		$2.25V \leq V_{DD_} \leq 2.75V$, $C_{L1} = 20pF$, $R_1 = 810\Omega$, $C_{L2} = 20pF$, $R_2 = 91\Omega$			61.0		70.1
		$1.71V \leq V_{DD_} \leq 1.89V$, $C_{L1} = 20pF$,			41.3		53.0

($V_{DD1} - V_{GND1} = 1.71V$ to $5.5V$, $V_{DD2} - V_{GND2} = 1.71V$ to $5.5V$, $C_L = 20pF$, $T_A = -40^\circ C$ to $+125^\circ C$, unless otherwise noted. (Note 5)
Typical values are at $V_{DD1} - V_{GND1} = 3.3V$, $V_{DD2} - V_{GND2} = 3.3V$, $T_A = +25^\circ C$, unless otherwise noted.)

PARAMETER	SYMBOL	CONDITIONS	MIN	TYP	MAX	UNITS
	t_{PHL21}	$R_1 = 470\Omega$, $C_{L2} = 20pF$, $R_2 = 81\Omega$				
		$4.5V \leq V_{DD_} \leq 5.5V$, $C_{L1} = 20pF$, $R_1 = 1.6k\Omega$, $C_{L2} = 20pF$, $R_2 = 180\Omega$		82.6	128.4	
		$3.0V \leq V_{DD_} \leq 3.6V$, $C_{L1} = 20pF$, $R_1 = 1k\Omega$, $C_{L2} = 20pF$, $R_2 = 120\Omega$		69.9	101.0	
		$2.25V \leq V_{DD_} \leq 2.75V$, $C_{L1} = 20pF$, $R_1 = 810\Omega$, $C_{L2} = 20pF$, $R_2 = 91\Omega$		65.1	88.9	
		$SDA2 = 0.3 \times V_{DD2}$ to $SDA1 = 0.3 \times V_{DD1}$				
		$SDA2 = 0.3 \times V_{DD2}$ to $SDA1 = 0.75V$		59.3	79.7	
Pulse-Width Distortion	PWD_{12}	$ t_{PLH12} - t_{PHL12} $	$4.5V \leq V_{DD_} \leq 5.5V$	56.1	94.2	ns
			$3.0V \leq V_{DD_} \leq 3.6V$	48.3	79.0	
			$2.25V \leq V_{DD_} \leq 2.75V$	43.6	70.6	
			$1.71V \leq V_{DD_} \leq 1.89V$	39.1	59.8	
	PWD_{21}	$ t_{PLH21} - t_{PHL21} $	$4.5V \leq V_{DD_} \leq 5.5V$	5.9	50.7	
			$3.0V \leq V_{DD_} \leq 3.6V$	12.6	43.1	
			$2.25V \leq V_{DD_} \leq 2.75V$	14.1	37.6	
			$1.71V \leq V_{DD_} \leq 1.89V$	18.0	35.1	
Round-Trip Propagation Delay on Side 1	t_{LOOP1}	$SDA1/SCL1 = 0.425V$ to $SDA1/SCL1 = 0.3 \times V_{DD1}$	$4.5V \leq V_{DD_} \leq 5.5V$, $C_{L1} = 40pF$, $R_1 = 1.6k\Omega$, $C_{L2} = 400pF$, $R_2 = 180\Omega$	142.2	163.2	ns
			$3.0V \leq V_{DD_} \leq 3.6V$, $C_{L1} = 40pF$, $R_1 = 1k\Omega$, $C_{L2} = 400pF$, $R_2 = 120\Omega$	114.1	133.5	
			$2.25V \leq V_{DD_} \leq 2.75V$, $C_{L1} = 40pF$, $R_1 = 810\Omega$, $C_{L2} = 400pF$, $R_2 = 91\Omega$	101.3	122.8	
		$SDA1/SCL1 = 0.425V$ to $SDA1/SCL1 = 0.75V$				
		$1.71V \leq V_{DD_} \leq 1.89V$, $C_{L1} = 40pF$, $R_1 = 470\Omega$, $C_{L2} = 400pF$, $R_2 = 81\Omega$	100.5	128.4		
Side 1 Time from UVLO to Active State	t_{ACT}	V_{DD1} rising, V_{DD2} powered up for more than t_{HS_EN} and $SDA_/SCL_high$		1.1	1.7	ms

($V_{DD1} - V_{GND1} = 1.71V$ to $5.5V$, $V_{DD2} - V_{GND2} = 1.71V$ to $5.5V$, $C_L = 20pF$, $T_A = -40^{\circ}C$ to $+125^{\circ}C$, unless otherwise noted. ([Note 5](#))
Typical values are at $V_{DD1} - V_{GND1} = 3.3V$, $V_{DD2} - V_{GND2} = 3.3V$, $T_A = +25^{\circ}C$, unless otherwise noted.)

PARAMETER	SYMBOL	CONDITIONS		MIN	TYP	MAX	UNITS
Input Power Loss to Output High-Z	t_{Hi-Z}	Opposite $V_{DD_}$ falling below $V_{UVLO_}$				0.4	ms
HOT SWAP/BUS STUCK TIMER, SIDE 2							
Precharge Voltage	V_{PRECHG}	SDA2/SCL2 open, $V_{DD2} > 0.6V$	At power-up		$0.3 \times V_{DD2}$		V
Precharge Thevenin Equivalent Impedance	R_{PRECHG}	SDA2/SCL2 open, $V_{DD2} > 0.6V$	At power-up		140		k Ω
Precharge Glitch Filter on SDA2/SCL2	t_{PRE_GLITCH}	V_{DD2} rising above V_{UVLO}	At power-up		220		ns
Hot-Swap Detection Enable Time	t_{HS_EN}	At power-up			102		ms
SDA2/SCL2 Idle Detection Time	t_{IDLE}	After t_{HS_EN}	At power-up		75		μs
Bus Stuck Timeout	t_{STUCK}	Either SDA1 or SCL1 low			102		ms

Note 1: All devices are 100% production tested at $T_A = +25^{\circ}C$. Specifications over temperature are guaranteed by design.

Note 2: All currents into the device are positive. All currents out of the device are negative. All voltages are referenced to their respective ground (GND1 or GND2), unless otherwise noted.

Note 3: The supply current does not include any current entering the SDA_/SCL_ pins. Current is after successful hot-swap connection. $R_1 = R_2 = 1k\Omega$, $C_{L1} = C_{L2} = 10pF$.

Note 4: This is the minimum difference between the output logic-low level and the input logic threshold. This ensures that there is no possibility of the part latching up the bus to which it is connected.

Note 5: Not production tested. Guaranteed by design.

Note 6: CMTI is the maximum sustainable common-mode voltage slew rate while maintaining operation. CMTI applies to both rising and falling common-mode voltage edges. Tested with the transient generator connected between GND1 and GND2 ($V_{CM} = 1000V$).

Timing Diagrams

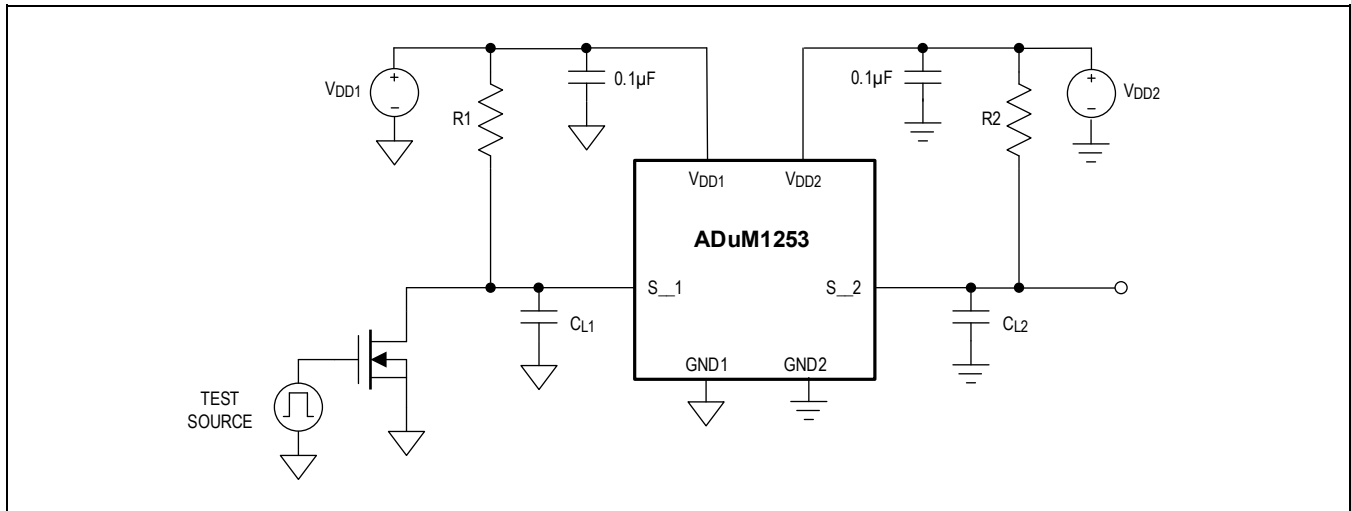

Figure 1. Timing Test Diagram

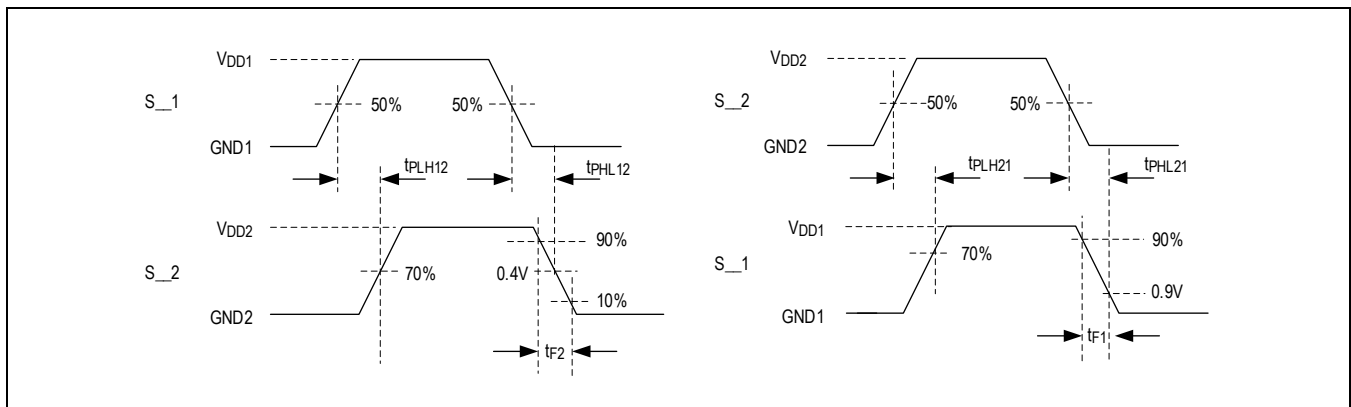

Figure 2. Timing Parameter Definition

Safety Limits

Damage to the IC can result in a low-resistance path to ground or to the supply and, without current limiting, the ADuM1253 can dissipate excessive amounts of power. Excessive power dissipation can damage the die and result in damage to the isolation barrier, potentially causing downstream issues. The safety limits for the ADuM1253 are listed in the package specific [Isolation Characteristics](#) table.

The maximum safety temperature (T_S) for the device is the +150°C maximum junction temperature specified in the [Absolute Maximum Ratings](#). See the [Thermal Considerations](#) section for details on determining the junction temperature.

[Figure 3](#) and [Figure 4](#) show the thermal derating curves for safety limiting the power and the current for the device in the 8-lead Narrow SOIC (21-0041) package when mounted on the JEDEC 2S2P test card. Ensure that the junction temperature does not exceed +150°C.

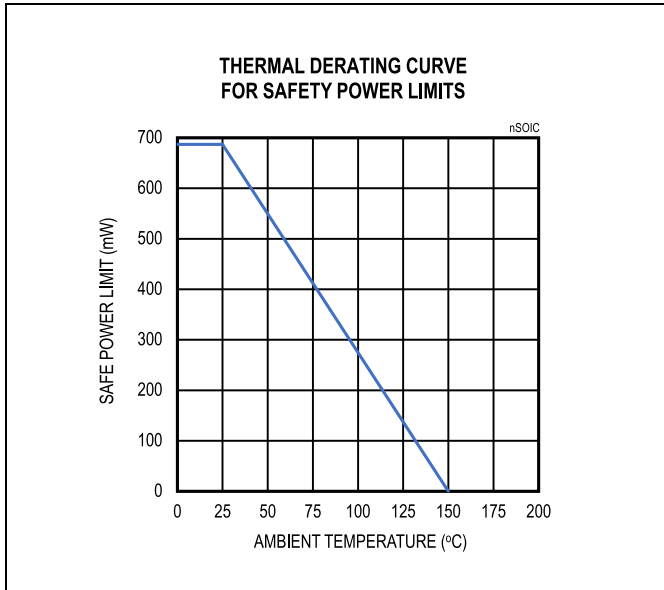

Figure 3. Thermal Derating Curve for 8-Lead Narrow SOIC Package

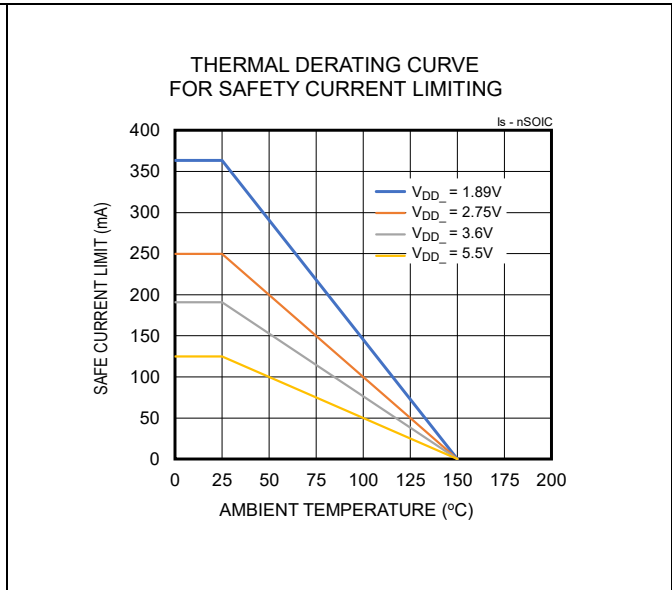

Figure 4. Thermal Derating Curve for Safety Current Limiting for 8-Lead Narrow SOIC Package

Figure 5 and Figure 6 show the thermal derating curves for safety limiting the power and the current of the device in the 8-lead Wide SOIC (21-100415) package when mounted on the JEDEC 2S2P test card. Ensure that the junction temperature does not exceed 150°C.

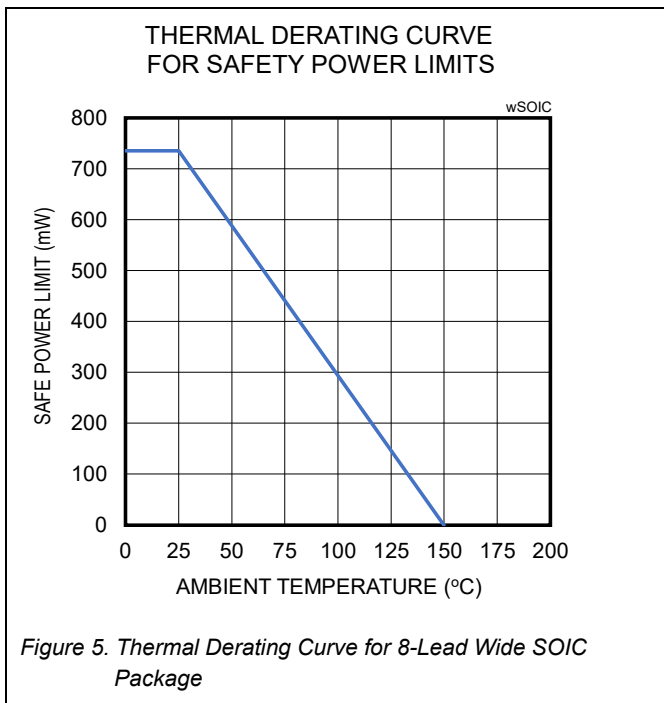

Figure 5. Thermal Derating Curve for 8-Lead Wide SOIC Package

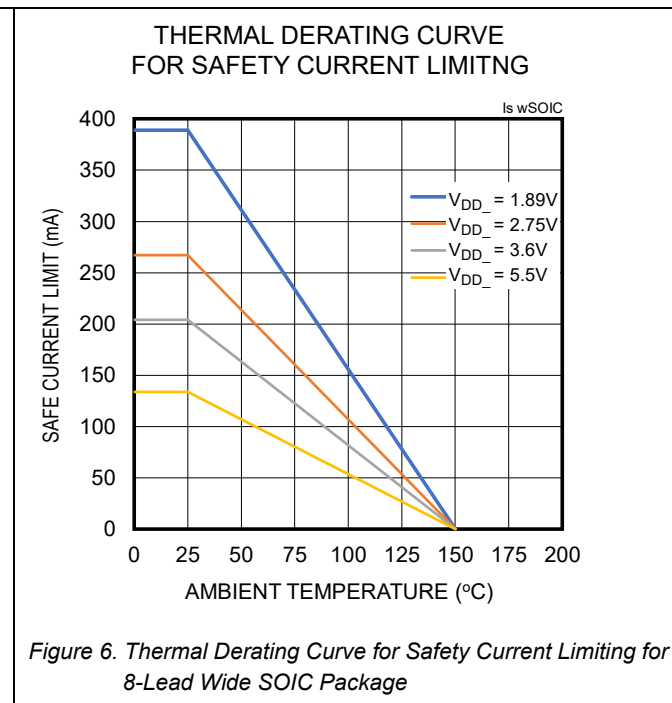

Figure 6. Thermal Derating Curve for Safety Current Limiting for 8-Lead Wide SOIC Package

Isolation Characteristics

8-Lead MSOP (21-0036) Isolation Characteristics

PARAMETER	SYMBOL	CONDITIONS	VALUE	UNITS
VOLTAGE (<i>Note 2</i>)				
Maximum Working Isolation Voltage	V_{IOWM}	Continuous RMS voltage (<i>Note 1</i>)	300	V_{RMS}
Maximum Withstanding Isolation Voltage	V_{ISO}	$f_{TEST} = 60\text{Hz}$, duration = 60s (<i>Note 1, Note 2</i>)	2500	V_{RMS}
PACKAGE CHARACTERISTICS				
External Clearance	CLR	Measured from input terminals to output terminals, shortest distance through air	3	mm
External Creepage	CPG	Measured from input terminals to output terminals, shortest distance along body	3	mm
Internal Clearance	DTI	Distance through insulation	21	μm
Comparative Tracking Index	CTI		> 400	V
Material Group		Material group (IEC 60112)	II	—
Resistance (Input to Output)	R_{IO}	$V_{IO} = 500\text{V}$, $T_A = +25^\circ\text{C}$ (<i>Note 3</i>)	10^{12}	Ω
		$V_{IO} = 500\text{V}$, $+100^\circ\text{C} \leq T_A \leq +125^\circ\text{C}$ (<i>Note 3</i>)	10^{11}	Ω
Capacitance (Input to Output)	C_{IO}	$f_{TEST} = 1\text{MHz}$ (<i>Note 3</i>)	1.5	pF

Note 1: V_{ISO} and V_{IOWM} are defined by the IEC 60747-17 standard.

Note 2: Insulation voltage guaranteed by design, not tested in production. Insulation is similar in structure to devices that are tested to 5 kV rms in production.

Note 3: Device is measured as a 2-terminal device with Pin 1 through Pin 4 connected and Pin 5 through Pin 8 connected.

8-Lead Narrow SOIC (21-0041) Isolation Characteristics

PARAMETER	SYMBOL	CONDITIONS	VALUE	UNITS
CLASSIFICATIONS				
Overvoltage Category per IEC60664-1		For rated mains voltage $\leq 150V_{RMS}$	I to IV	—
		For rated mains voltage $\leq 300V_{RMS}$	I to III	—
Climatic Classification			40/125/21	—
Pollution Degree		Per DIN VDE V 0110 (refer to <i>Table 1</i> of the DIN VDE standard)	2	—
VOLTAGE				
Maximum Working Isolation Voltage	V_{IOWM}	Continuous RMS voltage (<i>Note 1</i>)	445	V_{RMS}
Maximum Repetitive Isolation Voltage	V_{IORM}	(<i>Note 1</i>)	630	V_{PEAK}
Maximum Transient Isolation Voltage	V_{IOTM}	$t = 1\text{s}$ (<i>Note 1</i>)	4242	V_{PEAK}
Maximum Withstanding Isolation Voltage	V_{ISO}	$f_{TEST} = 60\text{Hz}$, duration = 60s (<i>Note 1, Note 2</i>)	3000	V_{RMS}
Maximum Surge Isolation Voltage, Reinforced	V_{IOSM}	Test method per IEC 60065, $V_{TEST} = 1.6 \times V_{IOSM} = 10000V_{PEAK}$ (<i>Note 1, Note 4</i>)	6250	V_{PEAK}
Maximum Impulse Voltage	V_{IMP}	Tested in air, $1.2\mu\text{s}/50\mu\text{s}$ waveform per IEC 62368-1	6000	V_{PEAK}
Input to Output Test Voltage	V_{PR}		1182	V_{PEAK}
Apparent Charge	q_{pd}	Method B1, $V_{PR} = 1.875 \times V_{IORM}$, $t = 1\text{s}$	5	pC
PACKAGE CHARACTERISTICS				
External Clearance	CLR	Measured from input terminals to output terminals, shortest distance through air	4	mm
External Creepage	CPG	Measured from input terminals to output terminals, shortest distance along body	4	mm
Internal Clearance	DTI	Distance through insulation	21	μm

PARAMETER	SYMBOL	CONDITIONS	VALUE	UNITS
Comparative Tracking Index	CTI		> 600	V
Material Group		Material group (IEC 60112)	I	—
Resistance (Input to Output)	R _{IO}	V _{IO} = 500V, T _A = +25°C (Note 3)	10 ¹²	Ω
		V _{IO} = 500V, +100°C ≤ T _A ≤ +125°C (Note 3)	10 ¹¹	Ω
	R _{IO_S}	V _{IO} = 500V, T _S = +150°C (Note 3)	10 ⁹	Ω
Capacitance (Input to Output)	C _{IO}	f _{TEST} = 1MHz (Note 3)	1.5	pF
SAFETY LIMITING VALUES				
Maximum Ambient Safety Temperature	T _S		150	°C
Maximum Input Power Dissipation	P _{SI}	θ _{JA} = 182°C/W, T _J = +150°C, T _A = +25°C	687	mW
Maximum Output Current	I _{SO}	θ _{JA} = 182°C/W, T _J = +150°C, T _A = +25°C, V _{DD} = 5.5V	124	mA
		θ _{JA} = 182°C/W, T _J = +150°C, T _A = +25°C, V _{DD} = 3.6V	190	mA
		θ _{JA} = 182°C/W, T _J = +150°C, T _A = +25°C, V _{DD} = 2.75V	249	mA
		θ _{JA} = 182°C/W, T _J = +150°C, T _A = +25°C, V _{DD} = 1.89V	363	mA

Note 1: V_{ISO}, V_{IOTM}, V_{IOWM}, V_{IORM} and V_{IOSM} are defined by the IEC 60747-17 standard.

Note 2: Product is qualified at V_{ISO} for 60s and 100% production tested at 120% of V_{ISO} for 1s.

Note 3: Device is measured as a 2-terminal device with Pin 1 through Pin 4 connected and Pin 5 through Pin 8 connected.

Note 4: Devices are immersed in oil during surge characterization.

8-Lead Wide SOIC (21-100415) Isolation Characteristics

PARAMETER	SYMBOL	CONDITIONS	VALUE	UNITS
CLASSIFICATIONS				
Overvoltage Category per IEC60664-1		For rated mains voltage $\leq 150 V_{RMS}$	I to IV	—
		For rated mains voltage $\leq 300 V_{RMS}$	I to IV	—
		For rated mains voltage $\leq 600 V_{RMS}$	I to IV	—
Climatic Classification			40/125/21	—
Pollution Degree		Per DIN VDE V 0110 (refer to Table 1 of the DIN VDE standard)	2	—
VOLTAGE				
Maximum Working Isolation Voltage	V_{IOWM}	Continuous RMS voltage (Note 1)	848	V_{RMS}
Maximum Repetitive Isolation Voltage	V_{IORM}	(Note 1)	1200	V_{PEAK}
Maximum Transient Isolation Voltage	V_{IOTM}	$t = 1s$ (Note 1)	7070	V_{PEAK}
Maximum Withstanding Isolation Voltage	V_{ISO}	$f_{TEST} = 60Hz$, duration = 60s (Note 1 , Note 2)	5000	V_{RMS}
Maximum Surge Isolation Voltage, Reinforced	V_{IOSM}	Test method per IEC 60065, $V_{TEST} = 1.6 \times V_{IOSM} = 10000V_{PEAK}$ (Note 1 , Note 4)	6250	V_{PEAK}
Maximum Impulse Voltage	V_{IMP}	Tested in air, 1.2 μ s/50 μ s waveform per IEC 62368-1	8000	V_{PEAK}
Input to Output Test Voltage	V_{PR}		2250	V_{PEAK}
Apparent Charge	q_{pd}	Method B1, $V_{PR} = 1.875 \times V_{IORM}$, $t = 1s$	5	pC
PACKAGE CHARACTERISTICS				
External Clearance	CLR	Measured from input terminals to output terminals, shortest distance through air	8	mm
External Creepage	CPG	Measured from input terminals to output terminals, shortest distance along body	8	mm
Internal Clearance	DTI	Distance through insulation	21	μ m
Comparative Tracking Index	CTI		> 600	V
Material Group		Material group (IEC 60112)	I	—
Resistance (Input to Output)	R_{IO}	$V_{IO} = 500V$, $T_A = +25^\circ C$ (Note 3)	10 ¹²	Ω
		$V_{IO} = 500V$, $+100^\circ C \leq T_A \leq +125^\circ C$ (Note 3)	10 ¹¹	Ω
	R_{IO_S}	$V_{IO} = 500V$, $T_S = +150^\circ C$ (Note 3)	10 ⁹	Ω
Capacitance (Input to Output)	C_{IO}	$f_{TEST} = 1MHz$ (Note 3)	1.5	pF
SAFETY LIMITING VALUES				
Maximum Ambient Safety Temperature	T_S		150	$^\circ C$
Maximum Input Power Dissipation	PSI	$\theta_{JA} = 170^\circ C/W$, $T_J = +150^\circ C$, $T_A = +25^\circ C$	735	mW
Maximum Output Current	ISO	$\theta_{JA} = 170^\circ C/W$, $T_J = +150^\circ C$, $T_A = +25^\circ C$, $V_{DD} = 5.5V$	133	mA
		$\theta_{JA} = 170^\circ C/W$, $T_J = +150^\circ C$, $T_A = +25^\circ C$, $V_{DD} = 3.6V$	204	mA
		$\theta_{JA} = 170^\circ C/W$, $T_J = +150^\circ C$, $T_A = +25^\circ C$, $V_{DD} = 2.75V$	267	mA
		$\theta_{JA} = 170^\circ C/W$, $T_J = +150^\circ C$, $T_A = +25^\circ C$, $V_{DD} = 1.89V$	388	mA

Note 1: V_{ISO} , V_{IOTM} , V_{IOWM} , V_{IORM} and V_{IOSM} are defined by the IEC 60747-17 standard.

Note 2: Product is qualified at V_{ISO} for 60s and 100% production tested at 120% of V_{ISO} for 1s.

Note 3: Device is measured as a 2-terminal device with Pin 1 through Pin 4 connected and Pin 5 through Pin 8 connected.

Note 4: Devices are immersed in oil during surge characterization.

Regulatory Information

The ADuM1253 has been approved by the organizations listed below. Certifications are available at [Safety and Regulatory Certifications for Digital Isolation](#).

8-Lead Narrow SOIC (21-0041) Package Certifications

REGULATORY AGENCY	STANDARD CERTIFICATION/APPROVAL	FILE
UL	UL 1577 component recognition program (Note 1): Single/basic 3000V _{RMS} isolation voltage.	(Pending)
CSA	CSA No 14-18 (Note 2 and Note 3): CSA 62368-1:19, IEC 62368-1:2018 Ed. 3 and EN62368-1:2020+A11:2020: Basic insulation at 400V _{RMS} . CSA 61010-1-12+A1 and IEC 61010-1 3rd Ed.: Basic insulation at 300V _{RMS} from mains, 400V _{RMS} from secondary circuit.	(Pending)
VDE	IEC 60747-17 (Note 4): Reinforced insulation, maximum transient isolation voltage 4242V _{PK} , maximum repetitive peak isolation voltage 630V _{PK} .	(Pending)
CQC	GB 4943.1-2022: Basic insulation at 400V _{RMS} (565V _{PEAK}) maximum working voltage, tropical climate, altitude < 5000m	(Pending)
TUV Sud	IEC 62368-1:2018 Ed. 3 and EN62368-1:2020+A11:2020: Basic insulation at 400V _{RMS}	(Pending)

Note 1: In accordance with UL 1577, each ADuM1253ASA+ is proof tested by applying an insulation test voltage $\geq 3600V_{RMS}$ for 1 second (current leakage detection limit = 5 μ A).

Note 2: Working voltages are quoted for material group III case material in pollution degree 2. ADuM1253ASA+ case material has been evaluated by CSA as material group I.

Note 3: The creepage and clearance distances have been evaluated for altitudes < 2000m, material group III, in pollution degree 2 and overvoltage category II, except where specified above.

Note 4: In accordance with IEC 60747-17, each ADuM1253 is proof tested by applying an insulation test voltage $\geq 1182V$ peak for 1s (partial discharge detection limit = 5 pC). This coupler is suitable for “safe electrical insulation” only within the safety ratings. Compliance with the safety ratings shall be ensured by means of suitable protective circuits.

8-Lead Wide SOIC (21-00415) Package Certifications

REGULATORY AGENCY	STANDARD CERTIFICATION/APPROVAL	FILE
UL	UL 1577 component recognition program (Note 1): Single/basic 5000V _{RMS} isolation voltage.	(Pending)
CSA	CSA No 14-18 (Note 2 and Note 3): CSA 62368-1:19, IEC 62368-1:2018 Ed. 3 and EN62368-1:2020+A11:2020: Basic insulation at 800V _{RMS} . CSA 61010-1-12+A1 and IEC 61010-1 3rd Ed.: Basic insulation at 600V _{RMS} from mains, 800V _{RMS} from secondary circuit	(Pending)

VDE	IEC 60747-17 (Note 4): Reinforced insulation, maximum transient isolation voltage 7070V _{PK} , maximum repetitive peak isolation voltage 1200V _{PK} .	(Pending)
CQC	GB 4943.1-2022: Basic insulation at 800V _{RMS} (1131V _{PEAK}) maximum working voltage, tropical climate, altitude < 5000m	(Pending)
TUV Sud	IEC 62368-1:2018 Ed. 3 and EN62368-1:2020+A11:2020: Basic insulation at 800V _{RMS}	(Pending)

- Note 1:** In accordance with UL 1577, each ADuM1253AWA+ is proof tested by applying an insulation test voltage $\geq 6000V_{RMS}$ for 1 second (current leakage detection limit = 5 μ A).
- Note 2:** Working voltages are quoted for material group III case material in pollution degree 2. ADuM1253AWA+ case material has been evaluated by CSA as material group I.
- Note 3:** The creepage and clearance distances have been evaluated for altitudes < 2000m, material group III, in pollution degree 2 and overvoltage category II, except where specified above.
- Note 4:** In accordance with IEC 60747-17, each ADuM1253 is proof tested by applying an insulation test voltage $\geq 2250V$ peak for 1s (partial discharge detection limit = 5 pC). This coupler is suitable for "safe electrical insulation" only within the safety ratings. Compliance with the safety ratings shall be ensured by means of suitable protective circuits.

Typical Operating Characteristics

(Typical values are at $V_{DD1} = V_{DD2} = 3.3V$, $GND1 = GND2$, $T_A = +25^\circ C$, unless otherwise noted. $C_L = 20pF$, $R_{PULLUP} = 1k\Omega$ and $1nF$, $100nF$ and $1\mu F$ decoupling capacitors are on V_{DD1} and V_{DD2} . All tests were performed using the ADuM1252SEVKIT#.)

SIDE 1 SUPPLY CURRENT vs. DATA RATE

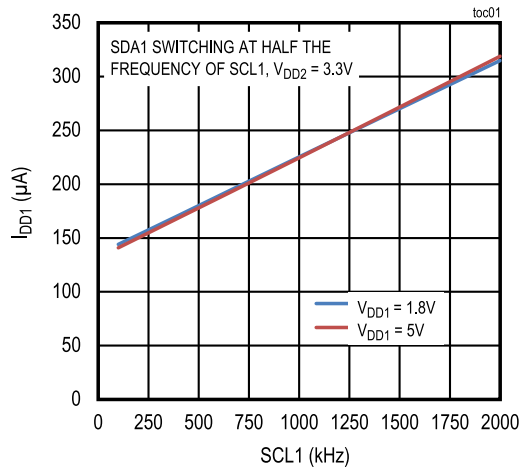

SIDE 2 SUPPLY CURRENT vs. DATA RATE

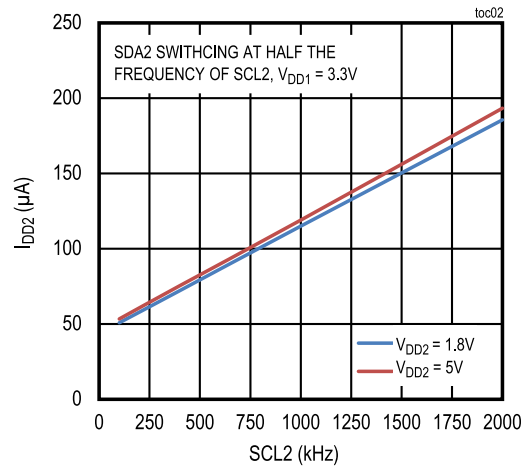

PROPAGATION DELAY t_PLH12 vs. TEMPERATURE

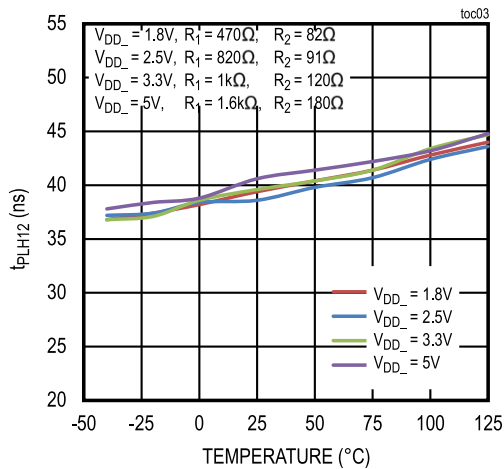

PROPAGATION DELAY t_PLH21 vs. TEMPERATURE

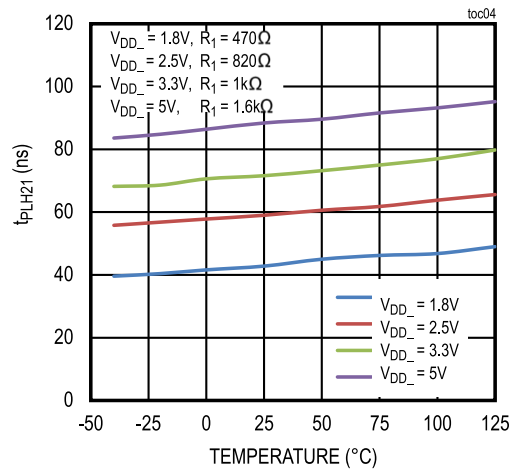

PROPAGATION DELAY t_{PHL12} vs. TEMPERATURE

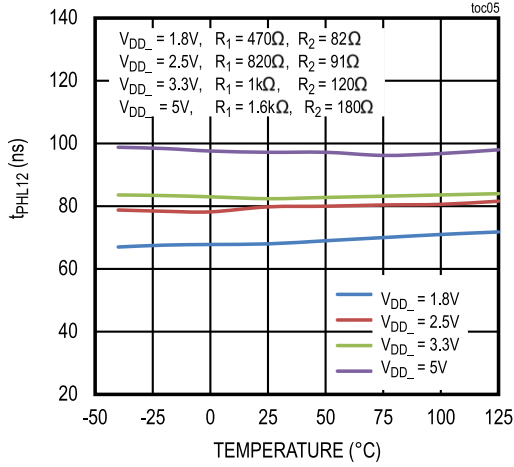

PROPAGATION DELAY t_{PHL21} vs. TEMPERATURE

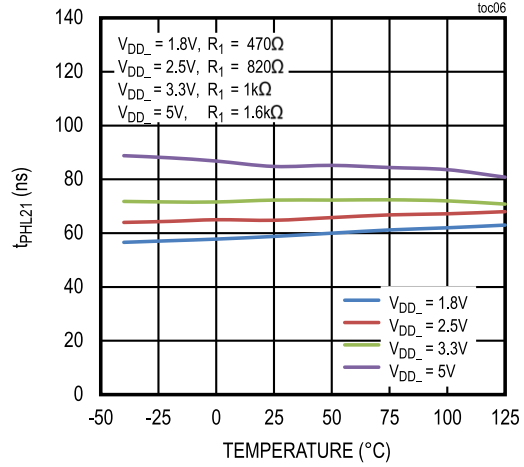

SIDE 1 OUTPUT LOW VOLTAGE vs. TEMPERATURE

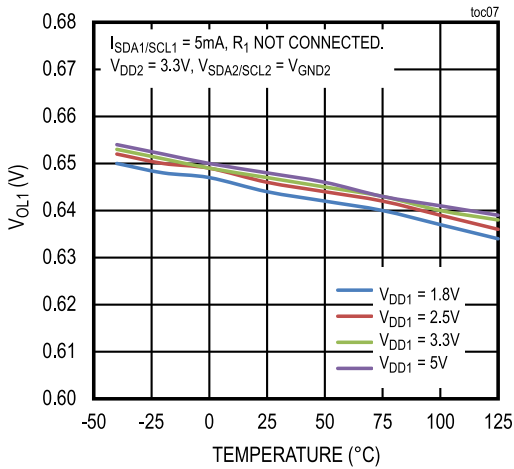

SIDE 1 OUTPUT FALL TIME vs. TEMPERATURE

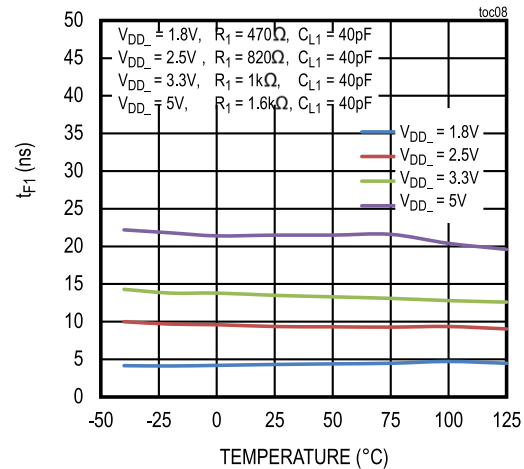

t_{F1} MEASURED FROM:
 $V_{DD} = 1.8V: 0.7V_{DD1}$ TO $0.75V$
 $V_{DD} = 2.5V, 3.3V, \text{ OR } 5V: 0.7V_{DD1}$ TO $0.3V_{DD1}$

SIDE 2 OUTPUT FALL TIME vs. TEMPERATURE

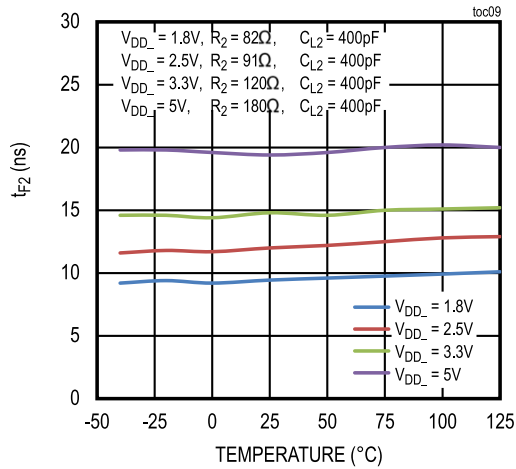

t_{F2} MEASURED FROM: $0.7V_{DD2}$ TO $0.3V_{DD2}$

t_{LOOP1} vs. TEMPERATURE

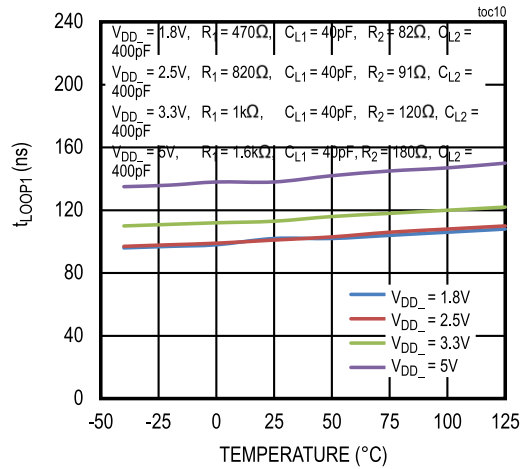

Pin Configuration

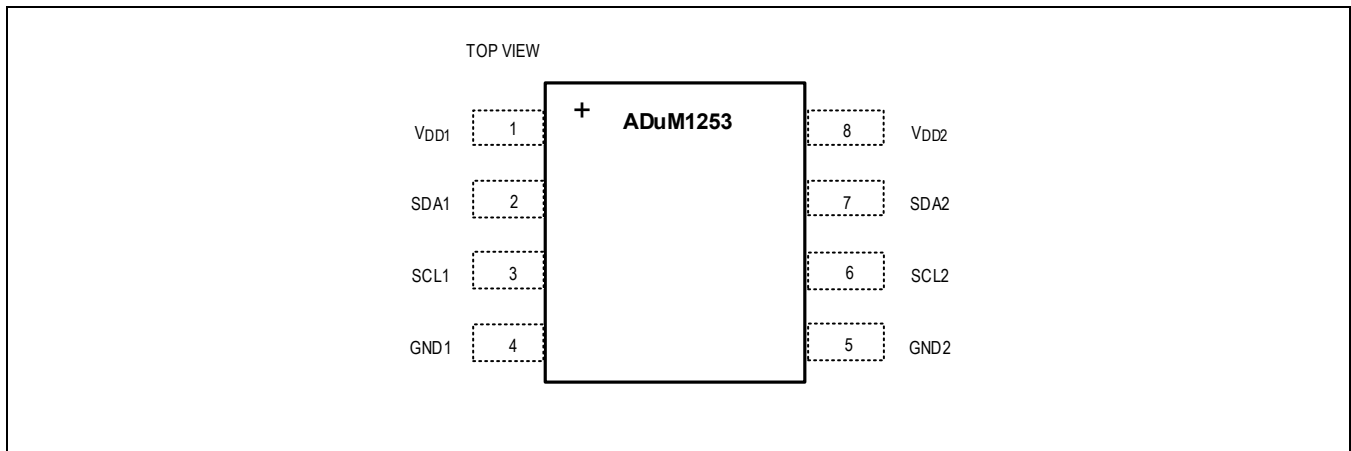

Pin Description

PIN	NAME	FUNCTION
1	V_{DD1}	Supply Voltage Side 1. Bypass V_{DD1} with a 1nF and a 0.1 μ F ceramic capacitor as close as possible to the pin.
2	SDA1	Serial Data Input/Output on Side 1. SDA1 is translated to/from SDA2 and is an open-drain output.
3	SCL1	Serial Clock Input on Side 1. SCL1 is translated to SCL2 and is an input.
4	GND1	Ground Reference for Side 1
5	GND2	Ground Reference for Side 2
6	SCL2	Serial Clock Output on Side 2. SCL2 is translated from SCL1 and is an open-drain output.
7	SDA2	Serial Data Input/Output on Side 2. SDA2 is translated to/from SDA1 and is an open-drain output.
8	V_{DD2}	Supply Voltage Side 2. Bypass V_{DD2} with a 1nF and a 0.1 μ F ceramic capacitor as close as possible to the pin.

Functional Diagram

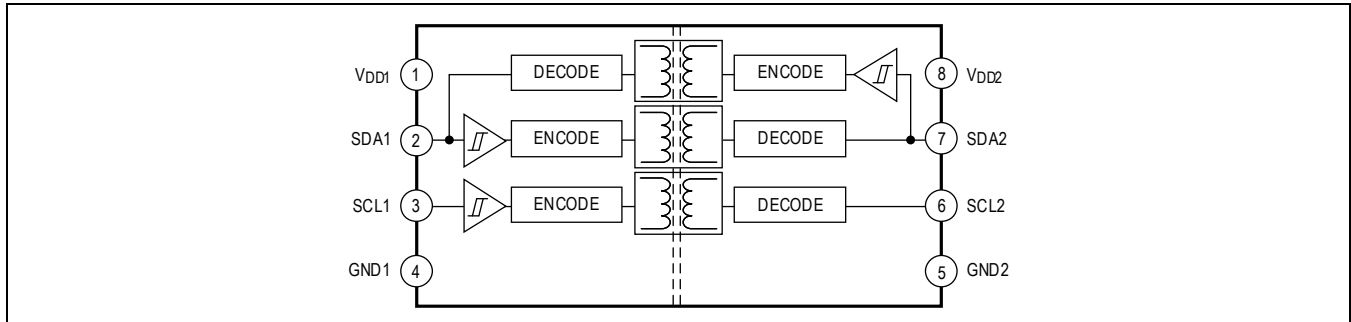

Detailed Description

The ADuM1253 is a two-channel I²C isolator utilizing Analog Devices, Inc. proprietary process technology. The device transfers digital signals between circuits with different power domains at ambient temperatures up to +125°C.

The device offers two open-drain channels, one bidirectional for data and one unidirectional for clock and is suitable for I²C applications where only a single clock direction across the isolation barrier is required. Example applications include I²C bus topologies where all I²C controllers are located on one side of the isolation barrier and/or where clock stretching is not used by devices on the non-controller side of the isolation barrier.

The device features independent 1.71V to 5.5V supplies on each side of the isolator. The device operates with SCL frequencies up to 2MHz. The wide temperature range and high isolation voltage make the device ideal for use in harsh industrial environments.

Digital Isolation

The ADuM1253 provides reinforced galvanic isolation for digital signals that are transmitted between two ground domains.

In the 8-pin MSOP package (21-0036), the ADuM1253 withstands voltage differences of up to 2.5kV_{RMS} for up to 60 seconds and up to 424V_{PEAK} of continuous isolation.

In the 8-pin narrow SOIC package (21-0041), the ADuM1253 withstands voltage differences of up to 3kV_{RMS} for up to 60 seconds and up to 630V_{PEAK} of continuous isolation.

In the 8-pin wide SOIC package (21-100415), the ADuM1253 withstands voltage differences of up to 5kV_{RMS} for up to 60 seconds and up to 1200V_{PEAK} of continuous isolation.

Bidirectional Channels

The ADuM1253 device features one bidirectional channel which has open-drain outputs.

The bidirectional channels do not require a direction control input. A logic-low on one side causes the corresponding pin on the other side to be pulled low while avoiding data latching within the device due to the coordination of the side 1 output logic-low voltage (V_{OL1}) and input logic-low threshold (V_{IL1}). The side 1 outputs utilize special buffers that regulate V_{OL1} to approximately 0.64V while keeping V_{IL1} at least 50mV lower than V_{OL1} . This difference prevents an output logic-low on side 1 from being accepted as an input low and subsequently transmitted to side 2, thus, preventing a latching action. SDA2 and SCL2 are conventional outputs that do not regulate the logic-low output voltage.

Due to their special nature, the side 1 SDA/SCL pins of different ADuM1253 devices cannot be connected together. This restriction also includes pins on other devices which employ similar buffers or rise-time accelerators. The side 2 pins do not have this restriction. Therefore, the side 2 pins of the ADuM1253 can be connected to each other or to any other bidirectional buffer or level translator's pin, including the side 1 pins of the ADuM1253.

The ADuM1253's outputs are all open-drain and require pull-up resistors to their respective supplies to generate the logic-high output voltage. The output low voltages are guaranteed for sink currents of up to 50mA for side 2 and 5mA for side 1 (see the [Electrical Characteristics](#) table).

Startup and Undervoltage Lockout

The V_{DD1} and V_{DD2} supplies are both internally monitored for undervoltage conditions. Undervoltage events can occur during power-up, power-down, or during normal operation due to a sagging supply voltage. When an undervoltage condition is detected on either supply, all outputs go to their default states regardless of the state of the inputs as seen in [Table 1](#).

Table 1. Output Behavior During Undervoltage Condition

V_{DD1}	V_{DD2}	INPUT	V_{OUT1}	V_{OUT2}
Powered	Powered	High	High-Z	High-Z
Powered	Powered	Low	Low	Low
Undervoltage	Powered	Don't care	High-Z	High-Z
Powered	Undervoltage	Don't care	High-Z	High-Z

Level Shifting

The wide supply voltage range of both V_{DD1} and V_{DD2} allows the ADuM1253 to be used for level translation in addition to isolation. V_{DD1} and V_{DD2} can be independently set to any voltage from 1.71V to 5.5V. The supply voltage sets the logic level on the corresponding side of the isolator.

Hot Swap

The ADuM1253 includes special precharge circuitry on SDA2/SCL2 to prevent loading on the I²C bus lines while the supply is either unpowered or in the process of being powered on. When the supply is below the UVLO threshold, the ADuM1253 bus lines do not load the bus to avoid disrupting or corrupting an active I²C bus. If the isolator is plugged into a live backplane using a staggered connector, where the supply and ground make connection first followed by the bus lines, the SDA2 and SCL2 lines are precharged to $V_{DD2}/3$ to minimize the current required to charge the parasitic capacitance of the device. Once the device is fully powered on, the device I/O pins become active. However, the connection between side 1 and side 2 does not occur until after the side 2 bus either detects an I²C stop condition or the bus has been idle for 125 μ s. See [Figure 7](#).

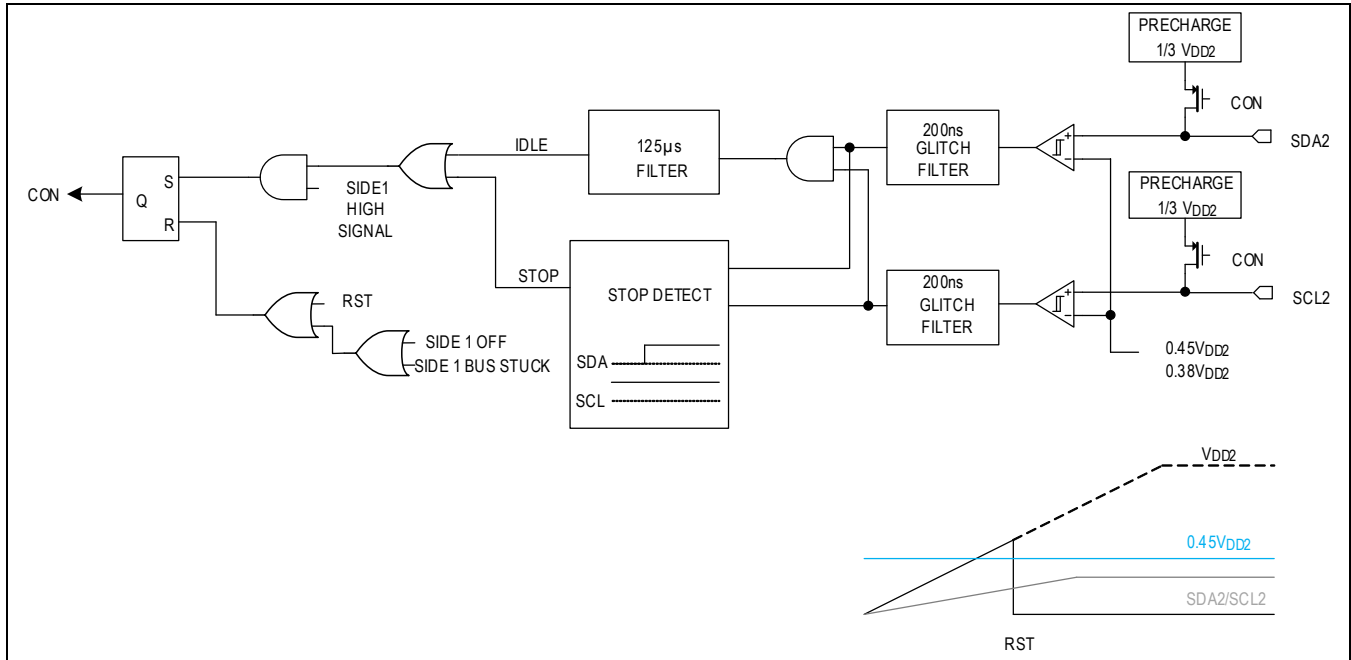

Figure 7. Bus Connection Logic

Bus Connection

The ADuM1253 connects the side 1 bus to the side 2 bus when both busses are idle or when side 1 is high and an I²C stop condition has been detected on side 2. If a stuck bus condition is detected on side 1, then the ADuM1253 disconnects the two busses to allow the external system to attempt a recovery.

Applications Information

Power-Supply Sequencing

The ADuM1253 does not require special power-supply sequencing. The logic levels are set independently on either side by V_{DD1} and V_{DD2} . Each supply can be present over the entire specified range regardless of the level or presence of the other supply.

Power-Supply Decoupling

To reduce ripple and the chance of introducing data errors especially if large common-mode transients are expected in the application, bypass V_{DD1} and V_{DD2} with 100nF and 1nF low-ESR ceramic capacitors to GND1 and GND2, respectively. Place the bypass capacitors as close to the power-supply input pins as possible.

Thermal Considerations

Thermal performance is directly linked to printed circuit board (PCB) design and operating environment. Pay careful attention to the PCB thermal design.

Thermal parameter values are specified in the [Package Information](#) section. θ_{JA} and θ_{JB} are mainly used to compare the thermal performance of the package of the device with other semiconductor packages when all test conditions listed are similar. Ψ_{JB} or Ψ_{JT} can be used to estimate the junction temperature when an accurate thermal measurement of the board temperature is available. The temperature measurement must be near the device under test (DUT) or directly on the package top surface, operating in the system environment.

θ_{JA} can be used for a first-order approximation to calculate the junction temperature in the system environment. The power dissipation (P_D), junction-to-ambient thermal impedance (θ_{JA}), and ambient temperature (T_A) determine the junction temperature (T_J) according to the expression:

$$T_J = T_A + (P_D \times \theta_{JA})$$

A more accurate estimate of the junction temperature can be found using Ψ_{JT} . Measure the device package temperature ($T_{PACKAGE}$) in the center of the package using an IR camera or thermocouple and then use the following expression:

$$T_J = T_{PACKAGE} + \Psi_{JT} \times P_D$$

Layout Considerations

The PCB designer should follow some critical recommendations to get the best performance from the design.

- Keep the input/output traces as short as possible. To keep signal paths low inductance, avoid using vias.
- Have a solid ground plane underneath the high-speed signal layer.
- Keep the area underneath the ADuM1253 free from ground and signal planes. Any galvanic or metallic connection between side 1 and side 2 defeats the isolation.

Typical Application Circuit

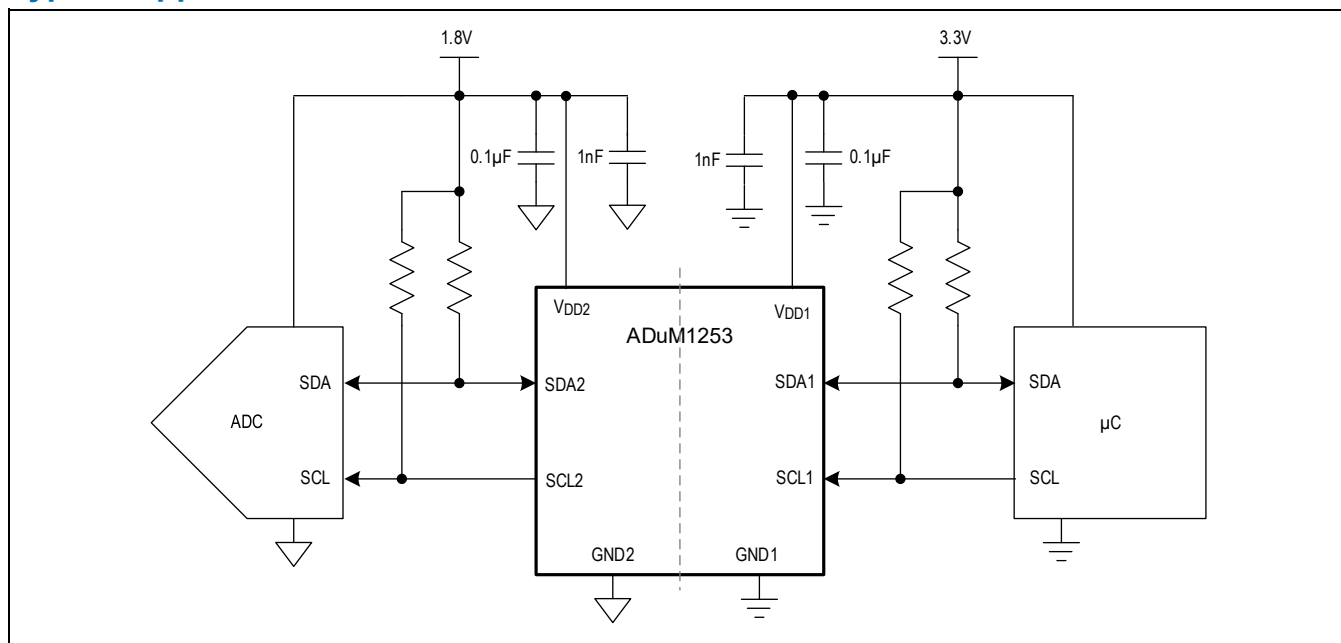

Ordering Information

PART NUMBER	TEMP RANGE	PIN-PACKAGE
ADuM1253AUA+	-40°C to +125°C	8 MSOP
ADuM1253AUA+T	-40°C to +125°C	8 MSOP
ADuM1253ASA+	-40°C to +125°C	8 Narrow SOIC
ADuM1253ASA+T	-40°C to +125°C	8 Narrow SOIC
ADuM1253AWA+	-40°C to +125°C	8 Wide SOIC
ADuM1253AWA+T	-40°C to +125°C	8 Wide SOIC

+ Denotes a lead (Pb)-free/RoHS-compliant package.

T = Tape and reel.

Chip Information

PROCESS: BiCMOS

Revision History

REVISION NUMBER	REVISION DATE	DESCRIPTION	PAGES CHANGED
0	10/23	Initial release	—
1	5/24	Added of MSOP and Wide SOIC packages, change Narrow SOIC safety limit current VDD from 5.6V to 5.5V, moved ESD characteristics to Electrical Characteristics table, clarified which parameters are guaranteed by design, removed statement that asterisk (*) marking branded on the component designates DIN IEC60747-17 approval, and added statement on safe electrical isolation to Package Certifications table Note 4	1-14, 18, 21



Looking for pricing, stock, or lifecycle information?

Click below to explore more details on WIN SOURCE:

 [View ADUM1253ASA+T on WIN SOURCE](#)

 [Analog Devices Inc. Information](#)

Optimize Your Supply Chain with WIN SOURCE Solutions

-  Global Sourcing Solution
-  Obsolete Management
-  Cost Control Management
-  Shortage Management
-  Alternative Solution
-  Excess Inventory Management