

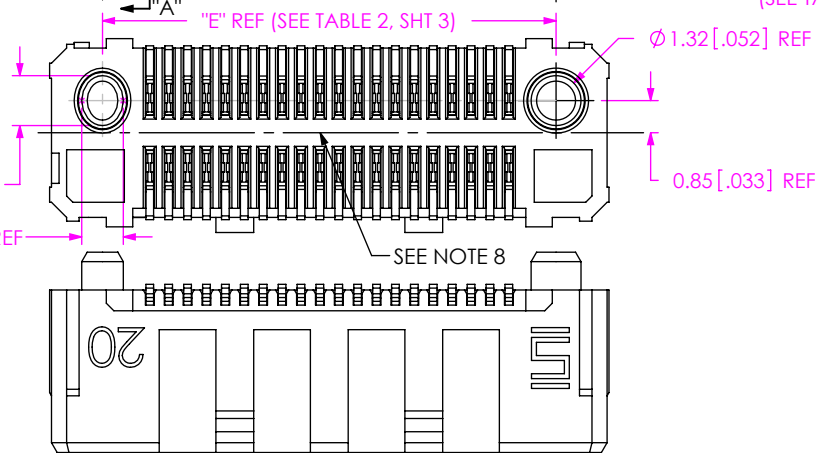

**THE DATASHEET OF  
LSHM-120-03.0-L-DV-A-S-K-TR**

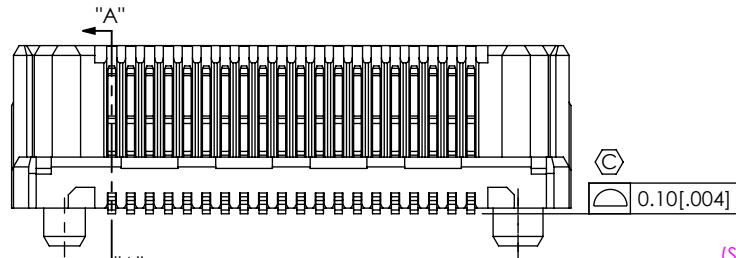

DO NOT SCALE FROM THIS PRINT

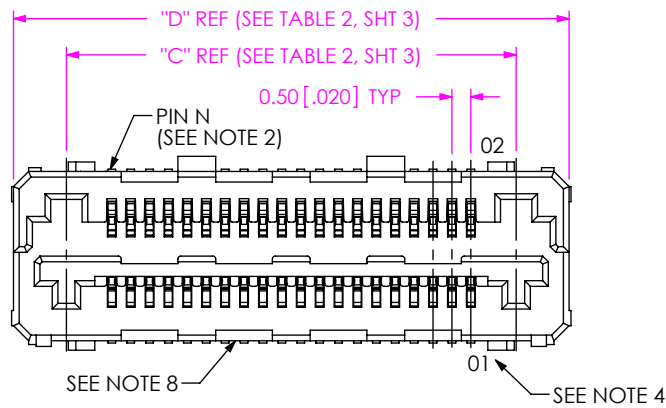

LSHM-1XX-XX.X-XXX-DV-A-X-X-XX

No OF POSITIONS  
05, 10, 20, 30, 40, 50

LEAD STYLE

- 02.5
- 03.0
- 04.0
- 06.0
- L2.5: LUBRICATED
- L3.0: LUBRICATED
- L4.0: LUBRICATED
- L6.0: LUBRICATED

PLATING SPECIFICATION

- L: 10µ" SELECTIVE GOLD IN CONTACT AREA, MATTE TIN ON TAIL
- F: 3µ" SELECTIVE GOLD IN CONTACT AREA, MATTE TIN ON TAIL
- S: 30µ" SELECTIVE GOLD IN CONTACT AREA, MATTE TIN ON TAIL
- H: 30µ" HEAVY GOLD IN CONTACT AREA, 3µ" GOLD ON TAIL
- SL: 30" SELECTIVE GOLD IN CONTACT AREA, TIN/LEAD (90/10 +/- 5%) TAIL (SEE NOTE 9) (SEE NOTE 11)

PACKAGING  
-TR: TAPE & REEL (SEE NOTE 6)  
-FR: FULL REEL QTY. TAPE & REEL (SEE NOTE 10)

OPTION  
-K: POLYIMIDE FILM (USE K-DOT-.138-.250-.005) (SEE FIG 3, SHT 3)

SHIELD  
S: WITH SHIELD  
N: NO SHIELD

TAIL OPTION  
DV:VERTICAL

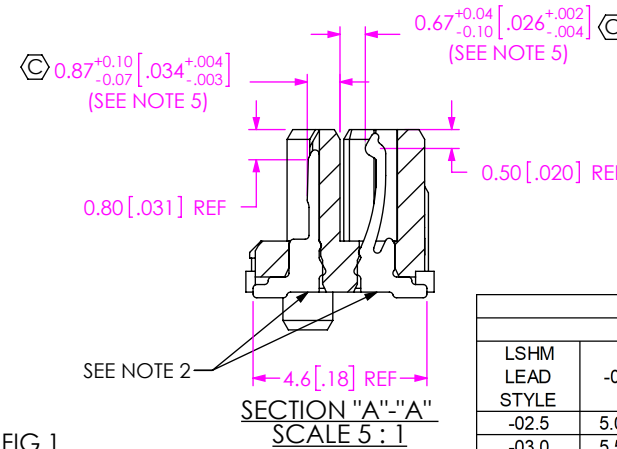
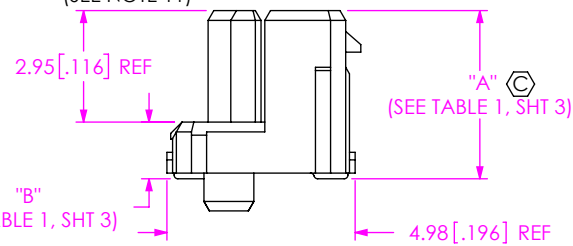
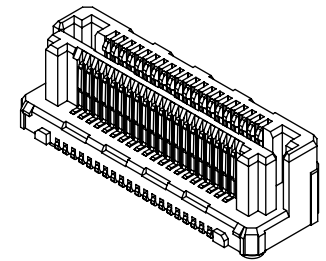

TABLE 4-REF STACK HEIGHT				
LSHM LEAD STYLE	-02.5	-03.0	-04.0	-06.0
-02.5	5.0MM	--	--	--
-03.0	5.5MM	6.0MM	--	--
-04.0	6.5MM	7.0MM	8.0MM	--
-06.0	8.5MM	9.0MM	10.0MM	12.0MM

NOTES:

1. Ⓢ REPRESENTS A CRITICAL DIMENSION.
2. BREAKOFF BURR ALLOWANCE .054 [.0021].
3. MINIMUM PUSHOUT FORCE; TERMINALS: 2.22 N [.5 LBS], CONTACTS: 2.22 N [.5 LBS].
4. WHEN MATING WITH ANOTHER LSHM-DV, PIN 01 WILL MATE WITH CONTACT 02 ON MATING CONNECTOR. WHEN MATING WITH A LSHM-DH, PIN 01 WILL MATE WITH PIN N, WHERE N=TOTAL NUMBER OF POSITIONS.
5. MEASURE FROM TOP OF VERTICAL WALL.
6. ORDERS WILL BE PACKAGED ACCORDING TO THE SAMTEC PACKAGING EFFICIENCY STANDARDS (SPES) FOUND ON WWW.SAMTEC.COM
7. FOR APPLICATION REQUIRING TWO OR MORE CONNECTORS PER BOARD, CONTACT IPG@SAMTEC.COM.
8. VOID CORING ON THIS SURFACE MAY VARY DEPENDING ON LEAD STYLE AND POSITION COUNT.
9. FOR SL/-STL PLATING:
  - USE SUB-C-261-X1-STL FOR -02.5 LEAD STYLE
  - USE SUB-C-185-X1-STL FOR -03.0 LEAD STYLE
  - ALL OTHER LEAD STYLES USE STANDARD -STL PLATED PIN
10. ATTACH LABEL-4X2 TO EACH REEL.
11. -STL CALLOUT IS VALID FOR EXISTING CUSTOMERS ONLY, NEW CUSTOMERS WILL USE -SL.

FIG 1

(LSHM-1XX-XX.X-XXX-DV-A-N-X-XX SHOWN)

**UNLESS OTHERWISE SPECIFIED, DIMENSIONS ARE IN MILLIMETERS(INCHES).**

TOLERANCES ARE:  
DECIMALS ANGLES  
X.X: ±0.3 [.01] 2°  
X.XX: ±0.13 [.005]  
X.XXX: ±0.051 [.0020]

**MATERIAL:** DO NOT SCALE DRAWING SHEET SCALE: 2:1  
INSULATOR: LCP, UL 94 V0; COLOR: BLACK  
CONTACT OR TERMINAL: PHOS BRONZE  
SHIELD: STAINLESS STEEL

**PROPRIETARY NOTE**  
THIS DOCUMENT CONTAINS CONFIDENTIAL AND PROPRIETARY INFORMATION AND ALL DESIGN, MANUFACTURING, REPRODUCTION, USE, PATENT RIGHTS AND SALES RIGHTS ARE EXPRESSLY RESERVED BY SAMTEC, INC. THIS DOCUMENT SHALL NOT BE DISCLOSED, IN WHOLE OR PART, TO ANY UNAUTHORIZED PERSON OR ENTITY NOR REPRODUCED, TRANSFERRED OR INCORPORATED IN ANY OTHER PROJECT IN ANY MANNER WITHOUT THE EXPRESS WRITTEN CONSENT OF SAMTEC, INC.

F:\DWG\MISC\MKTG\LSHM-1XX-XX.X-XXX-DV-A-X-X-XX-MKT.SLDRW

**DESCRIPTION:**  
0.50mm TERMINAL/SOCKET COMBO

DWG. NO.  
LSHM-1XX-XX.X-XXX-DV-A-X-X-XX

BY: AGEN H 10/30/2008 SHEET 1 OF 3



520 PARK EAST BLVD, NEW ALBANY, IN 47150  
PHONE: 812-944-6733 FAX: 812-948-5047  
e-Mail info@SAMTEC.com code 55322

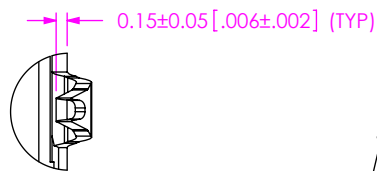
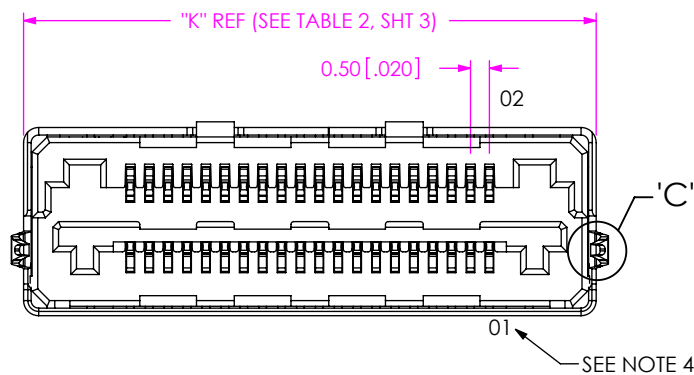

DETAIL 'C'  
SCALE 10:1

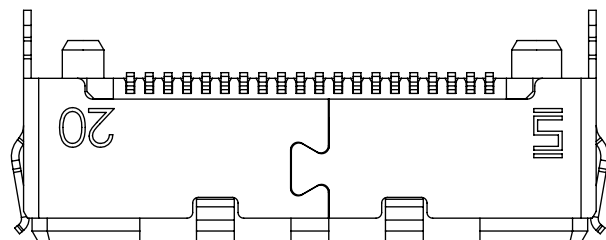
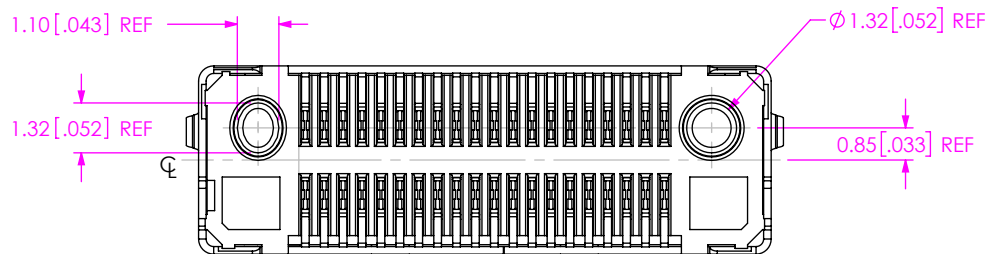
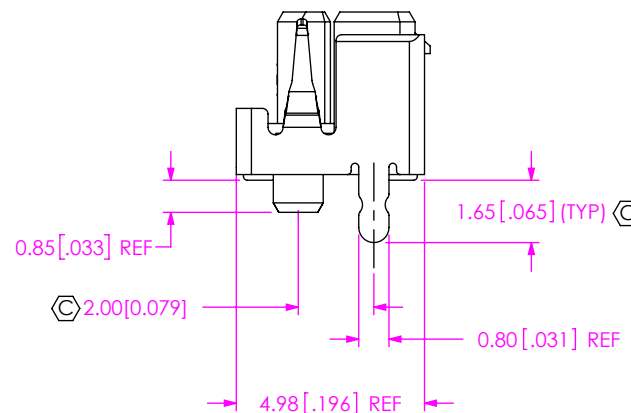
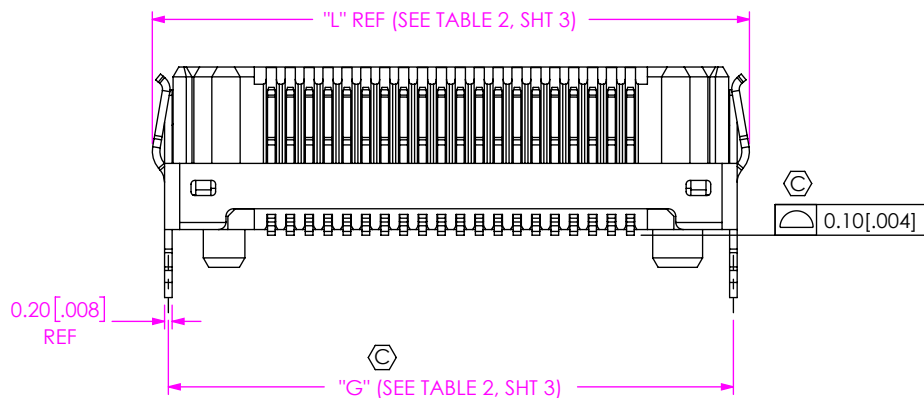
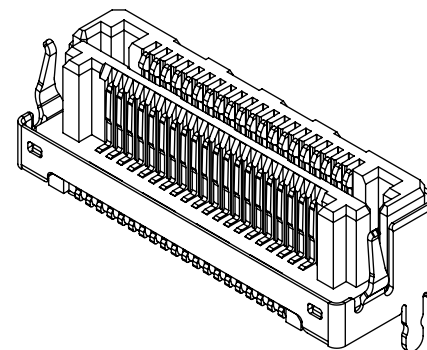

FIG 2  
(LSHM-1XX-XX.X-XXX-DV-A-S-X-XX SHOWN)

**PROPRIETARY NOTE**  
 THIS DOCUMENT CONTAINS CONFIDENTIAL AND PROPRIETARY INFORMATION AND ALL DESIGN, MANUFACTURING, REPRODUCTION, USE, PATENT RIGHTS AND SALES RIGHTS ARE EXPRESSLY RESERVED BY SAMTEC, INC. THIS DOCUMENT SHALL NOT BE DISCLOSED, IN WHOLE OR PART, TO ANY UNAUTHORIZED PERSON OR ENTITY NOR REPRODUCED, TRANSFERRED OR INCORPORATED IN ANY OTHER PROJECT IN ANY MANNER WITHOUT THE EXPRESS WRITTEN CONSENT OF SAMTEC, INC.

DO NOT SCALE DRAWING  
 SHEET SCALE: 1:0.2



520 PARK EAST BLVD, NEW ALBANY, IN 47150  
 PHONE: 812-944-6733 FAX: 812-948-5047  
 e-Mail info@SAMTEC.com code 55322

DESCRIPTION:  
 0.50mm TERMINAL/SOCKET COMBO

DWG. NO.  
 LSHM-1XX-XX.X-XXX-DV-A-S-X-XX

BY: AGEN H 10/30/2008 SHEET 2 OF 3

TABLE 1			
STYLE	"A"	"B"	"J"
-02.5	3.95 [0.156]	1.00 [0.039]	4.10 [0.161]
-03.0	4.45 [0.175]	1.50 [0.059]	4.60 [0.181]
-04.0	5.45 [0.215]	2.50 [0.098]	5.60 [0.220]
-06.0	7.45 [0.293]	4.50 [0.177]	7.60 [0.299]

TABLE 2							
No OF POS	"C"	"D"	"E"	"G"	"H"	"K"	"L"
-05	4.40 [0.173]	7.20 [0.283]	4.50 [0.177]	7.45 [0.293]	1.85 [0.073]	7.65 [0.301]	8.30 [0.327]
-10	6.90 [0.272]	9.70 [0.382]	7.00 [0.276]	9.95 [0.392]	3.10 [0.122]	10.15 [0.400]	10.80 [0.425]
-20	11.90 [0.469]	14.70 [0.579]	12.00 [0.472]	14.95 [0.589]	5.60 [0.220]	15.15 [0.596]	15.80 [0.622]
-30	16.90 [0.665]	19.70 [0.776]	17.00 [0.669]	19.95 [0.785]	8.10 [0.319]	20.15 [0.793]	20.80 [0.819]
-40	21.90 [0.862]	24.70 [0.972]	22.00 [0.866]	24.95 [0.982]	10.60 [0.417]	25.15 [0.990]	25.80 [1.016]
-50	26.90 [1.059]	29.70 [1.169]	27.00 [1.063]	29.95 [1.179]	13.10 [0.516]	30.15 [1.187]	30.80 [1.213]

TABLE 3				
LEAD STYLE	SHIELD	BODY	CONTACT (SEE NOTE 9)	SHIELD
-02.5	N	LSHM-XX-02.5-DV-A	C-261-01-XXX	N/A
-03.0	N	LSHM-XX-03.0-DV-A	C-185-01-XXX	N/A
-04.0	N	LSHM-XX-04.0-DV-A	C-185-03-XXX	N/A
-06.0	N	LSHM-XX-06.0-DV-A	C-185-02-XXX	N/A
-02.5	S	LSHM-XX-02.5-DV-A	C-261-01-XXX	SH26-XX-02.5-DV-N
-03.0	S	LSHM-XX-03.0-DV-A	C-185-01-XXX	SH26-XX-03.0-DV-N
-04.0	S	LSHM-XX-04.0-DV-A	C-185-03-XXX	SH26-XX-04.0-DV-N
-06.0	S	LSHM-XX-06.0-DV-A	C-185-02-XXX	SH26-XX-06.0-DV-N
-L2.5	N	LSHM-XX-02.5-DV-A	C-261-L1-XXX	N/A
-L3.0	N	LSHM-XX-03.0-DV-A	C-185-L1-XXX	N/A
-L4.0	N	LSHM-XX-04.0-DV-A	C-185-L3-XXX	N/A
-L6.0	N	LSHM-XX-06.0-DV-A	C-185-L2-XXX	N/A
-L2.5	S	LSHM-XX-02.5-DV-A	C-261-L1-XXX	SH26-XX-02.5-DV-N
-L3.0	S	LSHM-XX-03.0-DV-A	C-185-L1-XXX	SH26-XX-03.0-DV-N
-L4.0	S	LSHM-XX-04.0-DV-A	C-185-L3-XXX	SH26-XX-04.0-DV-N
-L6.0	S	LSHM-XX-06.0-DV-A	C-185-L2-XXX	SH26-XX-06.0-DV-N

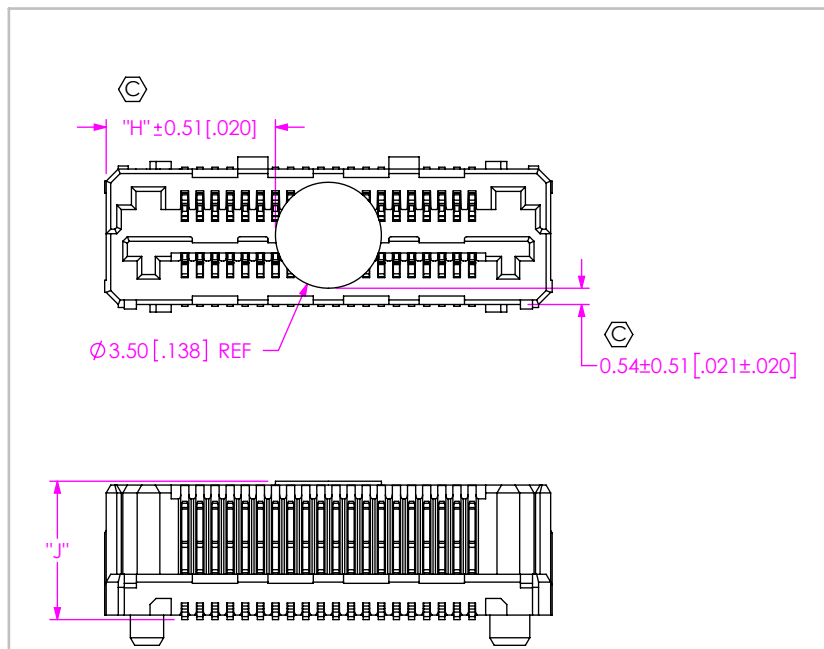

FIG 3  
-K OPTION  
(LSHM-120-XX.X-XXX-DV-A-N-K-XX SHOWN)

**PROPRIETARY NOTE**  
 THIS DOCUMENT CONTAINS CONFIDENTIAL AND PROPRIETARY INFORMATION AND ALL DESIGN, MANUFACTURING, REPRODUCTION, USE, PATENT RIGHTS AND SALES RIGHTS ARE EXPRESSLY RESERVED BY SAMTEC, INC. THIS DOCUMENT SHALL NOT BE DISCLOSED, IN WHOLE OR PART, TO ANY UNAUTHORIZED PERSON OR ENTITY NOR REPRODUCED, TRANSFERRED OR INCORPORATED IN ANY OTHER PROJECT IN ANY MANNER WITHOUT THE EXPRESS WRITTEN CONSENT OF SAMTEC, INC.



520 PARK EAST BLVD., NEW ALBANY, IN 47150  
 PHONE: 812-944-6733 FAX: 812-948-5047  
 e-Mail info@SAMTEC.com code 55322

DO NOT SCALE DRAWING  
 SHEET SCALE: 5:1



DESCRIPTION:  
 0.50mm TERMINAL/SOCKET COMBO

DWG. NO.  
 LSHM-1XX-XX.X-XXX-DV-A-X-X-XX

BY: AGEN H 10/30/2008 SHEET 3 OF 3

## Looking for pricing, stock, or lifecycle information?

Click below to explore more details on WIN SOURCE:

-  [View LSHM-120-03.0-L-DV-A-S-K-TR on WIN SOURCE](#)
-  [Samtec Inc. Information](#)

## Optimize Your Supply Chain with WIN SOURCE Solutions

-  Global Sourcing Solution
-  Obsolete Management
-  Cost Control Management
-  Shortage Management
-  Alternative Solution
-  Excess Inventory Management