

THC63LVDM83D-Z

24bit COLOR OPEN LDI(LVDS) TRANSMITTER

General Description

The THC63LVDM83D-Z transmitter is designed to support pixel data transmission between Host and Flat Panel Display up to 1080p/WUXGA resolutions.

The THC63LVDM83D-Z converts 28bits of LVC MOS data into four OpenLDI(LVDS) data streams. The transmitter can be programmed for rising edge or falling edge clock through a dedicated pin. At a transmit clock frequency of 160MHz, 24bits of RGB data and 4bits of timing and control data (HSYNC, VSYNC, DE, CONT1) are transmitted at an effective rate of 1120Mbps per OpenLDI(LVDS) channel.

Application

- Medium and Small Size Panel
- Tablet PC / Notebook PC
- Security Camera / Industrial Camera
- Multi Function Printer
- Industrial Equipment
- Medical Equipment Monitor
- Automotive

Features

- Compatible with TIA/EIA-644 LVDS Standard
- 7:1 OpenLDI(LVDS) Transmitter
- Operating Temperature Range : -40 to +105°C
- No Special Start-up Sequence Required
- Spread Spectrum Clocking Tolerant up to 100kHz Frequency Modulation and +/-2.5% Deviations.
- Wide Dot Clock Range: 8 to 160MHz Suited for
TV Signal : NTSC(12.27MHz) - 1080p(148.5MHz)
PC Signal : QVGA(8MHz) - WUXGA(154MHz)
- 56pin TSSOP Package
- 1.2V to 3.3V LVC MOS inputs are supported.
- LVDS swing is reducible as 200mV by RS-pin to reduce EMI and power consumption.
- PLL requires no external components.
- Power Down Mode
- Input clock triggering edge is selectable by R/F-pin.
- Compliant with RoHS and REACH

Block Diagram

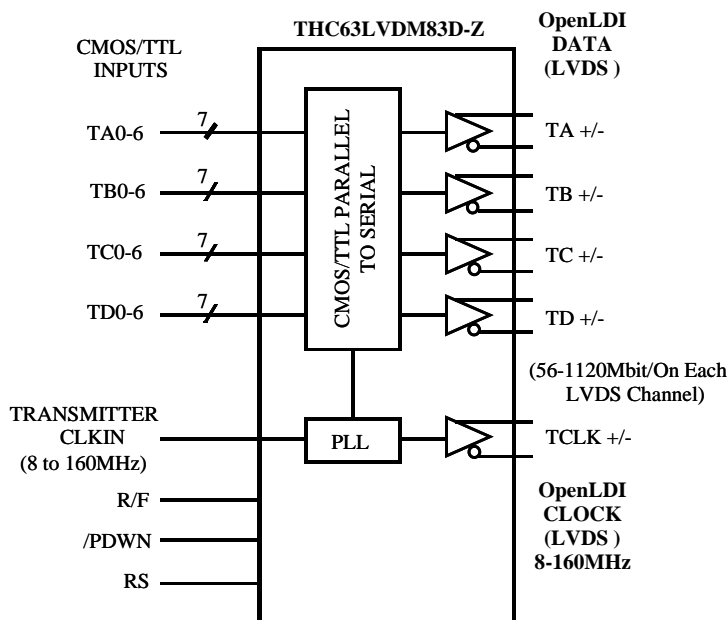

Figure 1. Block Diagram

Pin Diagram

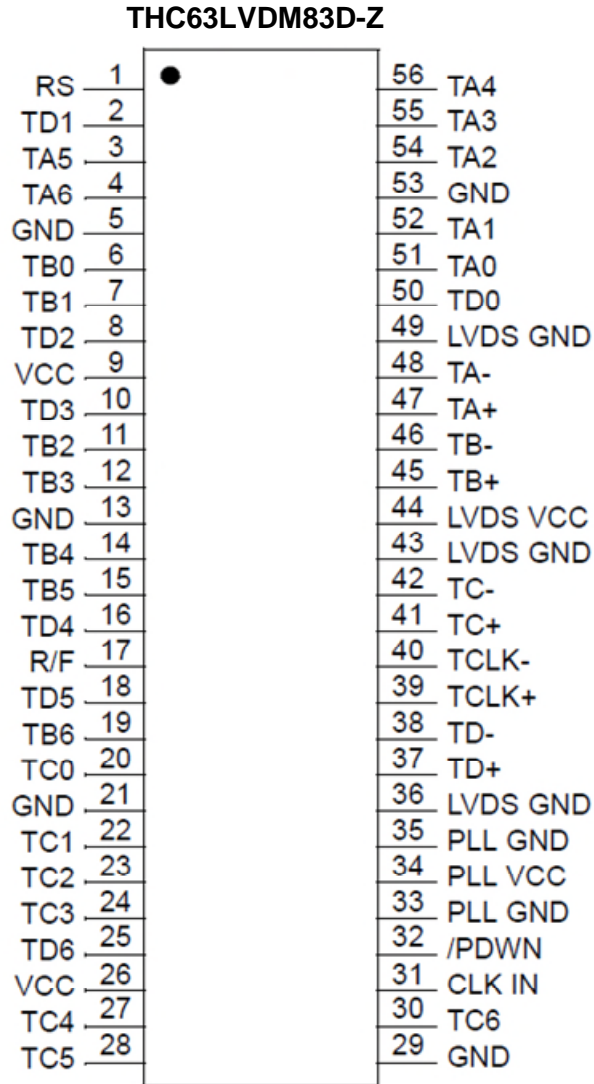

Figure 2. Pin Diagram

Pin Description

| Pin Name | Pin # | Direction | Type | Description | | |
|--------------|----------------------------|---|--------|---|------------|---------------------------|
| TA+, TA- | 47, 48 | Output | LVDS | Open LDI(LVDS) Data Out | | |
| TB+, TB- | 45, 46 | | | | | |
| TC+, TC- | 41, 42 | | | | | |
| TD+, TD- | 37, 38 | | | | | |
| TCLK+, TCLK- | 39, 40 | | | Open LDI(LVDS) Clock Out | | |
| TA0 ~ TA6 | 51, 52, 54, 55, 56, 3, 4 | Input | LVCMOS | Pixel Data Input | | |
| TB0 ~ TB6 | 6, 7, 11, 12, 14, 15, 19 | | | | | |
| TC0 ~ TC6 | 20, 22, 23, 24, 27, 28, 30 | | | | | |
| TD0 ~ TD6 | 50, 2, 8, 10, 16, 18, 25 | | | | | |
| /PDWN | 32 | | | H : Normal Operation L : Power Down (All outputs are Hi-Z) | | |
| RS | 1 | | | LVDS Swing Mode, VREF Select See Fig.7, 8 | | |
| | | | | RS | LVDS Swing | Small Swing Input Support |
| | | | | VCC | 350mV | N/A |
| | | | | 0.6V ~ 1.4V | 350mV | RS=VREF |
| | | | | GND ~ 0.2V | 200mV | N/A |
| | | VREF : is Input Reference Voltage | | | | |
| R/F | 17 | Input Clock Triggering Edge Select H : Rising Edge L : Falling Edge | | | | |
| CLKIN | 31 | Input Clock | | | | |
| VCC | 9, 26 | Power | - | Power Supply Pins for LVCMOS inputs and digital circuit. | | |
| GND | 5, 13, 21, 29, 53 | | | Ground Pins for LVCMOS Inputs and Digital Circuitry. | | |
| LVDS VCC | 44 | | | Power Supply Pins for LVDS Outputs. | | |
| LVDS GND | 36, 43 49 | | | Ground Pins for LVDS Outputs. | | |
| PLL VCC | 34 | | | Power Supply Pin for PLL Circuitry. | | |
| PLL GND | 33, 35 | | | Ground Supply Pin for PLL Circuitry. | | |

Absolute Maximum Ratings

| Parameter | Min | Max | Unit |
|---|------|-----------|------|
| All Supply Voltage (VCC, LVDS_VCC, PLL_VCC) | -0.3 | +4.0 | V |
| LVCMOS Input Voltage | -0.3 | VCC + 0.3 | V |
| LVDS Output Pin | -0.3 | VCC + 0.3 | V |
| Output Current | -30 | 30 | mA |
| Junction Temperature | - | +125 | °C |
| Storage Temperature | -55 | +150 | °C |
| Reflow Peak Temperature | - | +260 | °C |
| Reflow Peak Temperature Time | - | 10 | sec |
| Maximum Power Dissipation @+25°C | - | 1.8 | W |

Recommended Operating Conditions

| Symbol | Parameter | Min | Typ. | Max | Unit |
|------------------------------|-------------------------------|-----|------|------|------|
| VCC, LVDS_VCC, PLL_VCC | All Supply Voltage | 3.0 | 3.3 | 3.6 | V |
| T _a | Operating Ambient Temperature | -40 | 25 | +105 | °C |
| f _{clk} | Clock Frequency | 8 | - | 160 | MHz |

“Absolute Maximum Ratings” are those values beyond which the safety of the device cannot be guaranteed. They are not meant to imply that the device should be operated at these limits. The tables of “Electrical Characteristics Table4, 5, 6, 7” specify conditions for device operation.

“Absolute Maximum Rating” value also includes behavior of overshooting and undershooting.

Equivalent LVDS Output Schematic Diagram

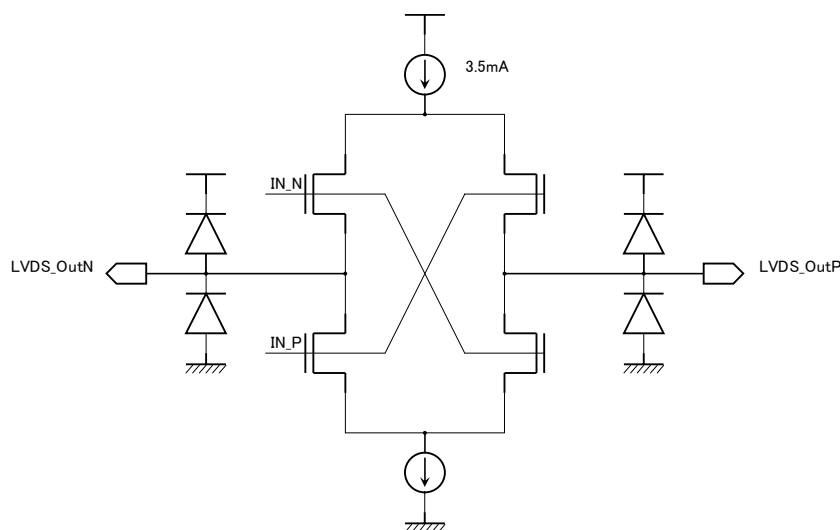

Figure 3. LVDS Output Schematic Diagram

Power Consumption

Over recommended operating supply and temperature range unless otherwise specified

| Symbol | Parameter | Conditions | Typ.* | Max | Unit |
|-------------------|---|-----------------------------------|-------|-----|------|
| I _{TCCW} | LVDS Transmitter Operating Current Worst Case Pattern (Fig.4) | RL=100Ω, CL=5pF, f=85MHz, RS=VCC | 48 | 67 | mA |
| | | RL=100Ω, CL=5pF, f=135MHz, RS=VCC | 65 | 83 | mA |
| | | RL=100Ω, CL=5pF, f=160MHz, RS=VCC | 73 | 92 | mA |
| | | RL=100Ω, CL=5pF, f=85MHz, RS=GND | 40 | 56 | mA |
| | | RL=100Ω, CL=5pF, f=135MHz, RS=GND | 56 | 71 | mA |
| | | RL=100Ω, CL=5pF, f=160MHz, RS=GND | 65 | 80 | mA |
| I _{TCCS} | LVDS Transmitter Power Down Current | /PDWN=L, All Inputs=L or H | - | 10 | μA |

*Typ. values are at the conditions of VCC=3.3V and Ta = +25°C

Worst Case Pattern

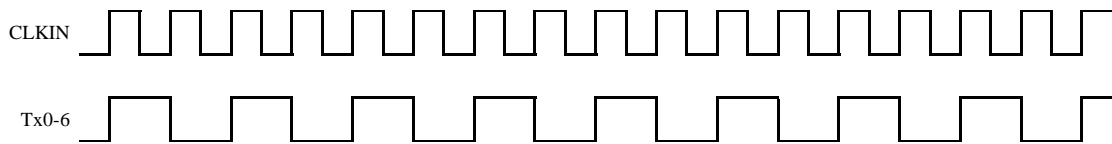

x=A,B,C,D

Figure 4. Worst Case Pattern

Electrical Characteristics

LVC MOS DC Specifications

Over recommended operating supply and temperature range unless otherwise specified

| Symbol | Parameter | Conditions | Min | Typ.* | Max | Unit |
|-------------------------------|--------------------------------------|--|-------------------------------|---------------------|-------------------------------|------|
| V _{IH} | High Level Input Voltage | RS=VCC or GND | 2.0 | - | VCC | V |
| V _{IL} | Low Level Input Voltage | RS=VCC or GND | GND | - | 0.8 | V |
| V _{DDQ} ¹ | Small Swing Voltage | - | 1.2 | - | 2.8 | V |
| V _{REF} | Input Reference Voltage | Small Swing (RS=V _{DDQ} /2) | - | V _{DDQ} /2 | - | |
| V _{SH} ² | Small Swing High Level Input Voltage | V _{REF} = V _{DDQ} /2 | V _{DDQ} /2 +150mV | - | - | V |
| V _{SL} ² | Small Swing Low Level Input Voltage | V _{REF} = V _{DDQ} /2 | - | - | V _{DDQ} /2 -150mV | V |
| I _{INC} | Input Current | GND ≤ V _{IN} ≤ VCC | - | - | ±10 | μA |

*Typ. values are at the conditions of VCC=3.3V and Ta = +25°C

Notes : ¹ V_{DDQ} voltage defines the max voltage of small swing inputs at RS=VREF. It is not an actual input voltage.

² Small swing signals are applied to TA0-6, TB0-6, TC0-6, TD0-6 and CLKIN.

LVDS Transmitter DC Specifications

Over recommended operating supply and temperature range unless otherwise specified

| Symbol | Parameter | Conditions | Min | Typ.* | Max | Unit |
|-----------------|---|--|-------|-------|-------|------|
| VOD | Differential Output Voltage | RL=100Ω Normal swing RS=VCC Ta=25°C | 250 | 350 | 450 | mV |
| | | Reduced swing RS=GND | 110 | 200 | 300 | mV |
| ΔVOD | Change in VOD between complementary output states | RL=100Ω | - | - | 35 | mV |
| VOC | Common Mode Voltage | RL=100Ω, Ta=25°C, RS=VCC | 1.125 | 1.25 | 1.375 | V |
| ΔVOC | Change in VOC between complementary output states | RL=100Ω | - | - | 35 | mV |
| I _{OS} | Output Short Circuit Current | V _{OUT} =GND, RL=100Ω | - | - | -24 | mA |
| I _{OZ} | Output TRI-STATE Current | /PDWN=GND, V _{OUT} =GND to VCC | - | - | ±10 | μA |

*Typ. values are at the conditions of VCC=3.3V and Ta = +25°C

LVC MOS & LVDS Transmitter AC Specifications

Over recommended operating supply and temperature range unless otherwise specified

| Symbol | Parameter | Min | Typ. | Max | Unit |
|------------|--|----------------|------|----------------|------|
| t_{TCIT} | CLK IN Transition Time | - | - | 5.0 | ns |
| t_{CP} | CLK IN Period | 6.25 | T | 125 | ns |
| t_{rCH} | CLK IN High Time | 0.35T | 0.5T | 0.65T | ns |
| t_{rCL} | CLK IN Low Time | 0.35T | 0.5T | 0.65T | ns |
| t_{rCD} | CLK IN to TCLK+/- Delay | 3T | - | 3T+4 | ns |
| t_{TS} | LVC MOS Data Setup to CLK IN | 2.0 | - | - | ns |
| t_{TH} | LVC MOS Data Hold from CLK IN | 0.0 | - | - | ns |
| t_{LVT} | LVDS Transition Time | - | 0.6 | 1.5 | ns |
| t_{sk} | Output Skew Accuracy(T=11.76ns) | - | 120 | 275 | ps |
| | Output Skew Accuracy(T=11.76ns) (3.2V≤VCC≤3.6V) | - | 120 | 250 | ps |
| | Output Skew Accuracy(T=7.4ns) | - | 120 | 250 | ps |
| t_{top1} | Output Data Position0 (T=6.25ns ~ 20ns) | - t_{sk} | 0.0 | + t_{sk} | ns |
| t_{top0} | Output Data Position1 (T=6.25ns ~ 20ns) | T/7- t_{sk} | T/7 | T/7+ t_{sk} | ns |
| t_{top6} | Output Data Position2 (T=6.25ns ~ 20ns) | 2T/7- t_{sk} | 2T/7 | 2T/7+ t_{sk} | ns |
| t_{top5} | Output Data Position3 (T=6.25ns ~ 20ns) | 3T/7- t_{sk} | 3T/7 | 3T/7+ t_{sk} | ns |
| t_{top4} | Output Data Position4 (T=6.25ns ~ 20ns) | 4T/7- t_{sk} | 4T/7 | 4T/7+ t_{sk} | ns |
| t_{top3} | Output Data Position5 (T=6.25ns ~ 20ns) | 5T/7- t_{sk} | 5T/7 | 5T/7+ t_{sk} | ns |
| t_{top2} | Output Data Position6 (T=6.25ns ~ 20ns) | 6T/7- t_{sk} | 6T/7 | 6T/7+ t_{sk} | ns |
| t_{PLL} | Phase Lock Loop Set | - | - | 1.0 | ms |

*Typ. values are at the conditions of VCC=3.3V and Ta = +25°C

LVC MOS Input

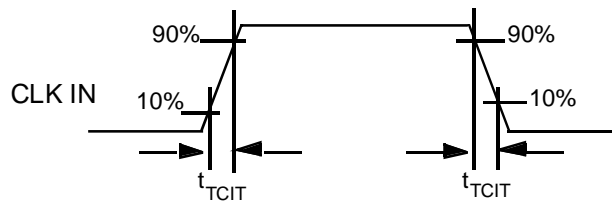
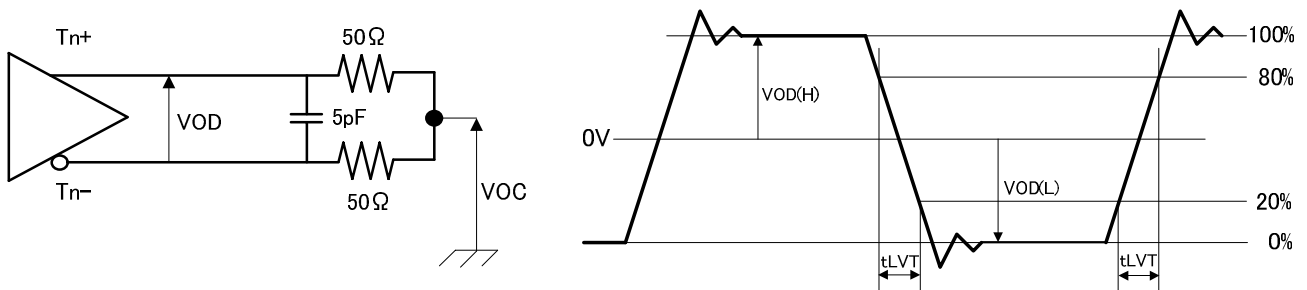

Figure 5. CLK IN Transmission Time

OpenLDI(LVDS) Output



LVDS Output Load

Figure 6. LVDS Output Load and Transmission Time

AC Timing Diagrams

LVC MOS Inputs

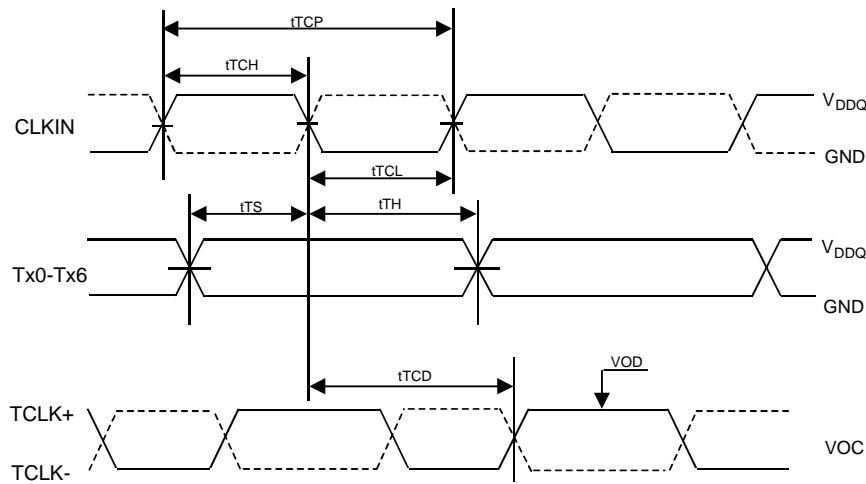

| RS | VOD |
|-------------|-------|
| VCC | 350mV |
| 0.6V ~ 1.4V | |
| GND ~ 0.2V | 200mV |

Note :
 CLKIN : Solid line denotes the setting of R/F=GND
 Dashed line denotes the setting of R/F = VCC

Figure 7. LVC MOS Inputs and LVDS Clock Output Timing 1

Small Swing Inputs

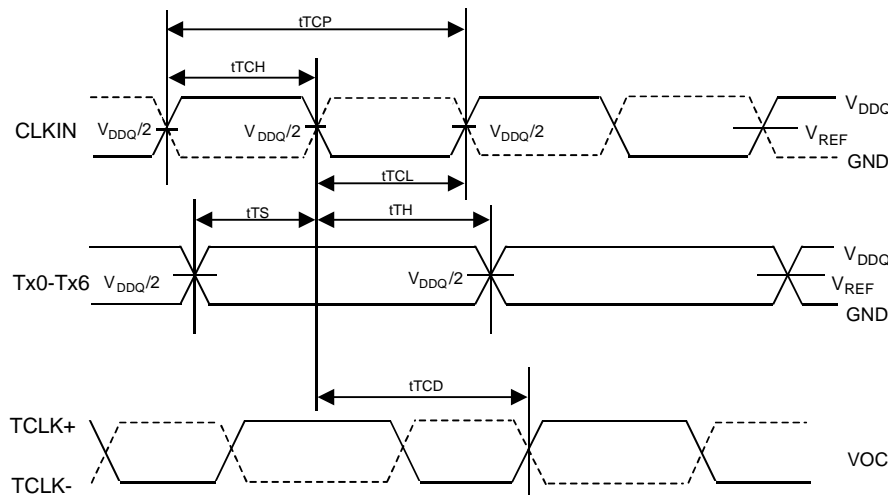

| RS | VREF |
|-------------|---------------------|
| VCC | -- |
| 0.6V ~ 1.4V | V _{DDQ} /2 |
| GND ~ 0.2V | -- |

Note :
 CLKIN : Solid line denotes the setting of R/F=GND
 Dashed line denotes the setting of R/F = VCC

Figure 8. LVC MOS Inputs and LVDS Output Timing 2

OpenLDI(LVDS) Output Data Position

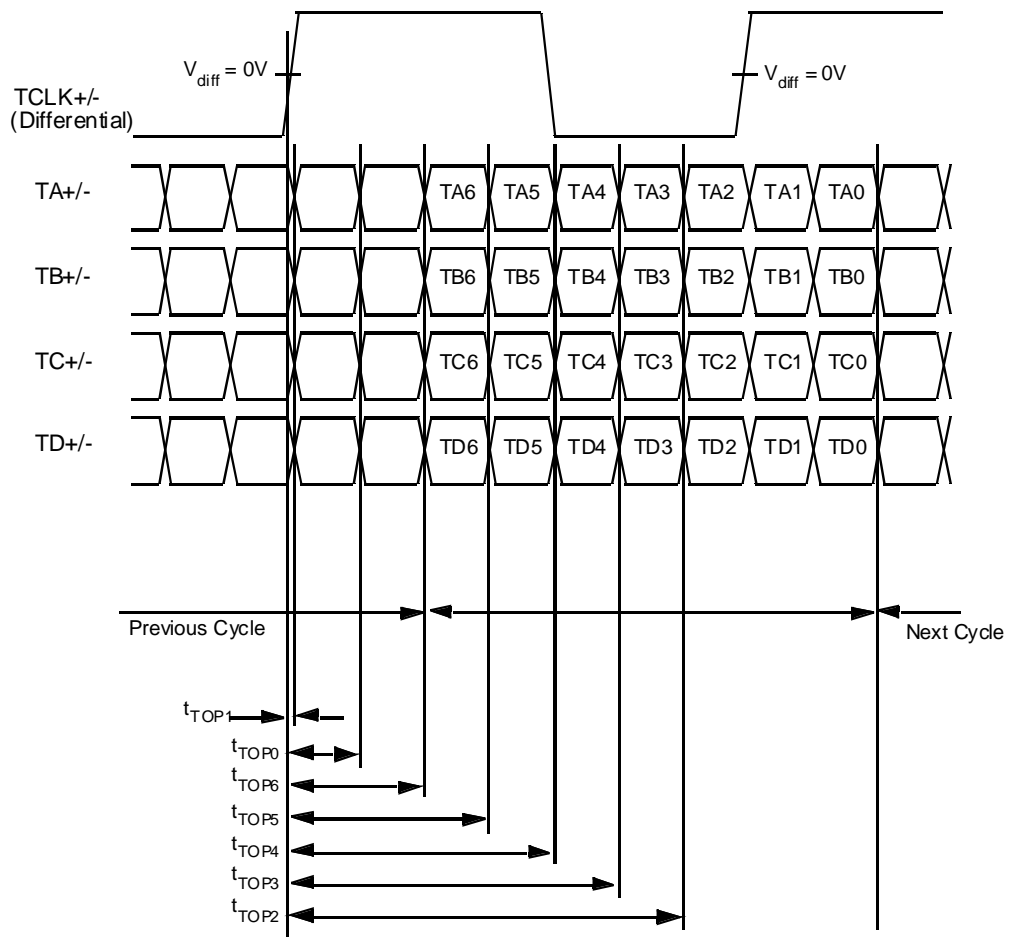

Figure 9. LVDS Output Data Position

Phase Lock Loop Set Time

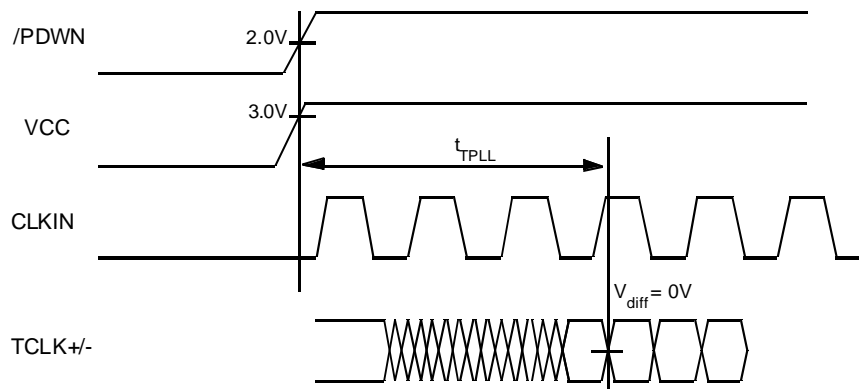

Figure 10. PLL Lock Loop Set Time

Spread Spectrum Clocking Tolerant

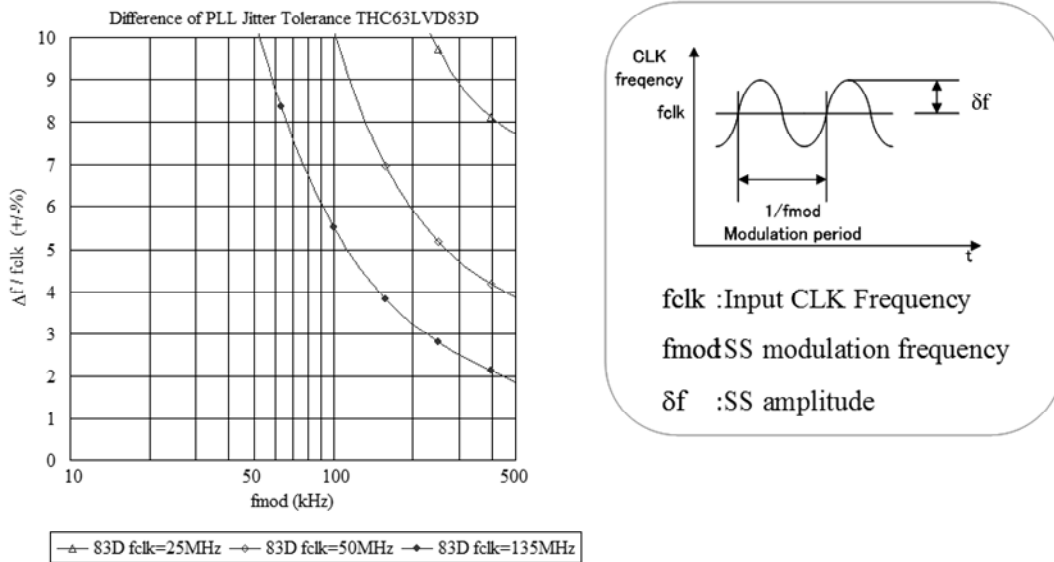

Figure 11. Spread Spectrum Clocking Tolerant

The graph indicates the range that the IC works normally under SS clock input operation. The results are measured with a typical sample on condition of +25C° and 3.3V, therefore these values are for reference and do not guarantee the performance of a product under other circumstance.

OpenLDI(LVDS) Data Timing Diagram

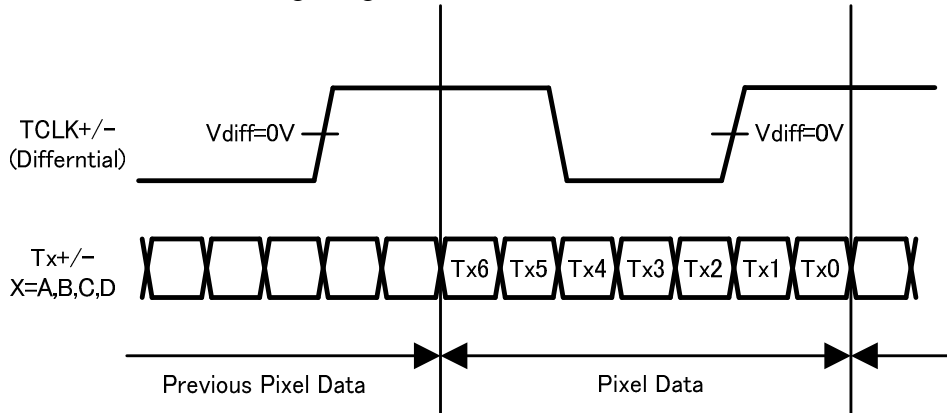

Figure 12. LVDS Data Timing Diagram

THC63LVDM83D-Z Pixel Data Mapping for JEIDA Format (6bit, 8bit Application)

| | 6bit | 8bit |
|-----|-------|-------|
| TA0 | R2 | R2 |
| TA1 | R3 | R3 |
| TA2 | R4 | R4 |
| TA3 | R5 | R5 |
| TA4 | R6 | R6 |
| TA5 | R7 | R7 |
| TA6 | G2 | G2 |
| TB0 | G3 | G3 |
| TB1 | G4 | G4 |
| TB2 | G5 | G5 |
| TB3 | G6 | G6 |
| TB4 | G7 | G7 |
| TB5 | B2 | B2 |
| TB6 | B3 | B3 |
| TC0 | B4 | B4 |
| TC1 | B5 | B5 |
| TC2 | B6 | B6 |
| TC3 | B7 | B7 |
| TC4 | Hsync | Hsync |
| TC5 | Vsync | Vsync |
| TC6 | DE | DE |
| TD0 | - | R0 |
| TD1 | - | R1 |
| TD2 | - | G0 |
| TD3 | - | G1 |
| TD4 | - | B0 |
| TD5 | - | B1 |
| TD6 | - | N/A |

Note : Use TA to TC channels and open TD channel for 6bit application.

THC63LVDM83D-Z Pixel Data Mapping for VESA Format (6bit, 8bit Application)

| | 6bit | 8bit |
|-----|-------|-------|
| TA0 | R0 | R0 |
| TA1 | R1 | R1 |
| TA2 | R2 | R2 |
| TA3 | R3 | R3 |
| TA4 | R4 | R4 |
| TA5 | R5 | R5 |
| TA6 | G0 | G0 |
| TB0 | G1 | G1 |
| TB1 | G2 | G2 |
| TB2 | G3 | G3 |
| TB3 | G4 | G4 |
| TB4 | G5 | G5 |
| TB5 | B0 | B0 |
| TB6 | B1 | B1 |
| TC0 | B2 | B2 |
| TC1 | B3 | B3 |
| TC2 | B4 | B4 |
| TC3 | B5 | B5 |
| TC4 | Hsync | Hsync |
| TC5 | Vsync | Vsync |
| TC6 | DE | DE |
| TD0 | - | R6 |
| TD1 | - | R7 |
| TD2 | - | G6 |
| TD3 | - | G7 |
| TD4 | - | B6 |
| TD5 | - | B7 |
| TD6 | - | N/A |

Note : Use TA to TC channels and open TD channel for 6bit application.

Notes

1) Cable Connection and Disconnection

Do not connect and disconnect the OpenLDI(LVDS) cable, when the power is supplied to the system.

2) GND Connection

Connect each GND of the PCB which THC63LVDM83D-Z and OpenLDI(LVDS)-Rx on it. It is better for EMI reduction to place GND cable as close to OpenLDI(LVDS) cable as possible.

3) Multi Drop Connection

Multi drop connection is not recommended.

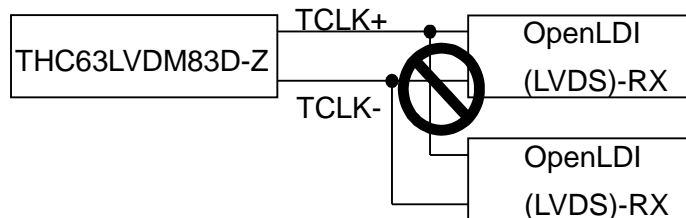

Figure 14. Multi Drop Connection

4) Asynchronous use

Asynchronous using such as following systems is not recommended.

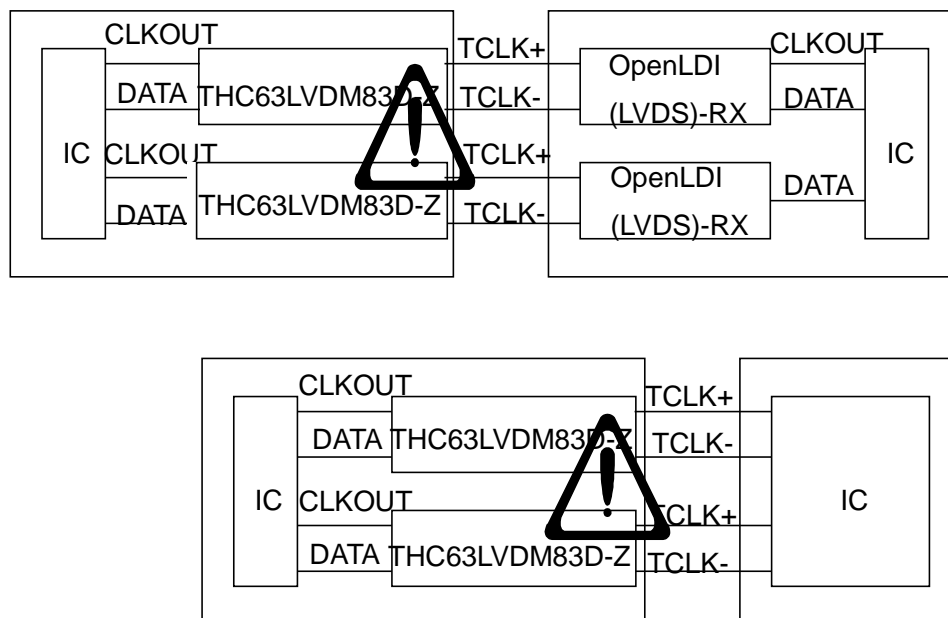

Figure 15. Asynchronous Use

Package

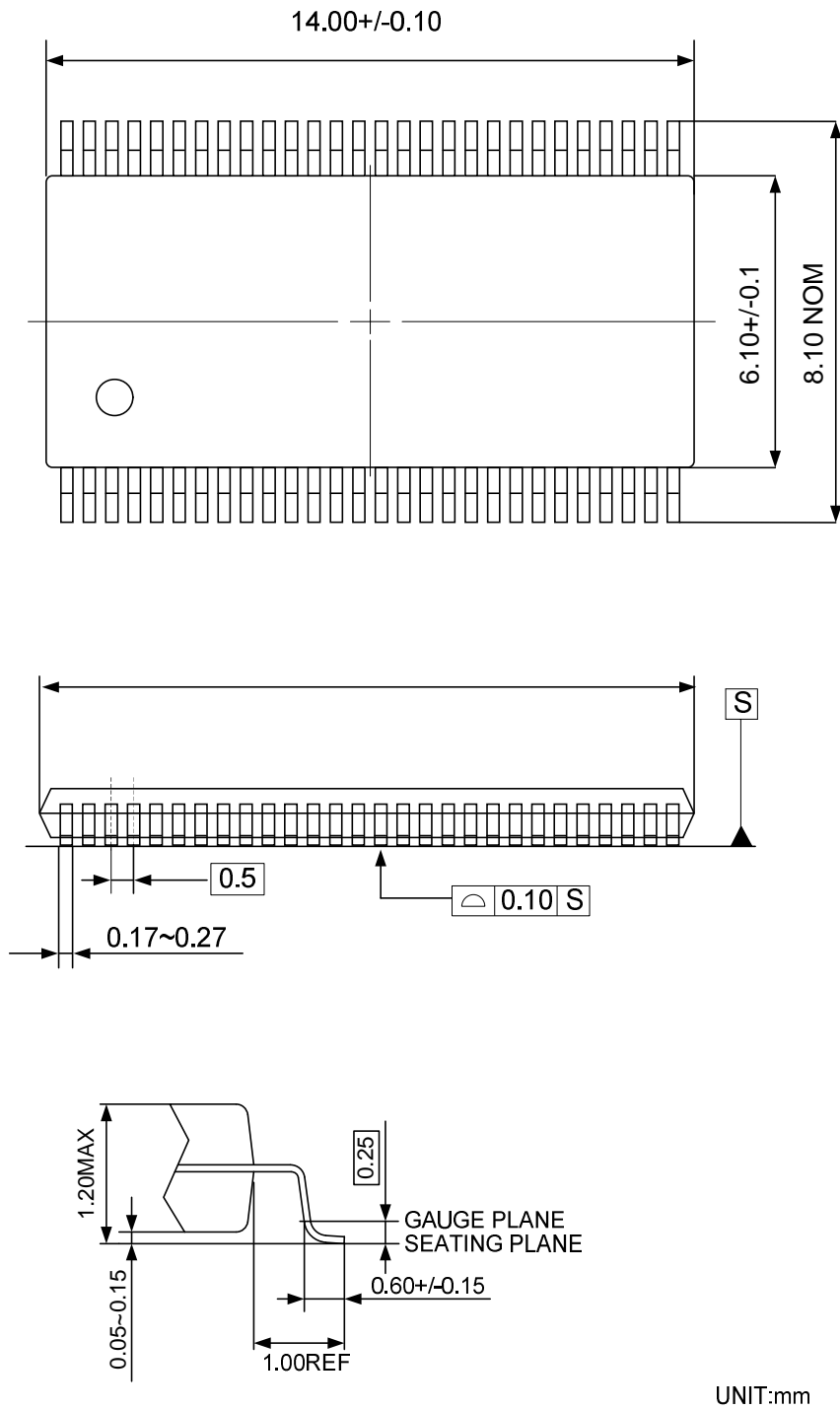

Figure 16. Package Diagram

Reference Land Pattern

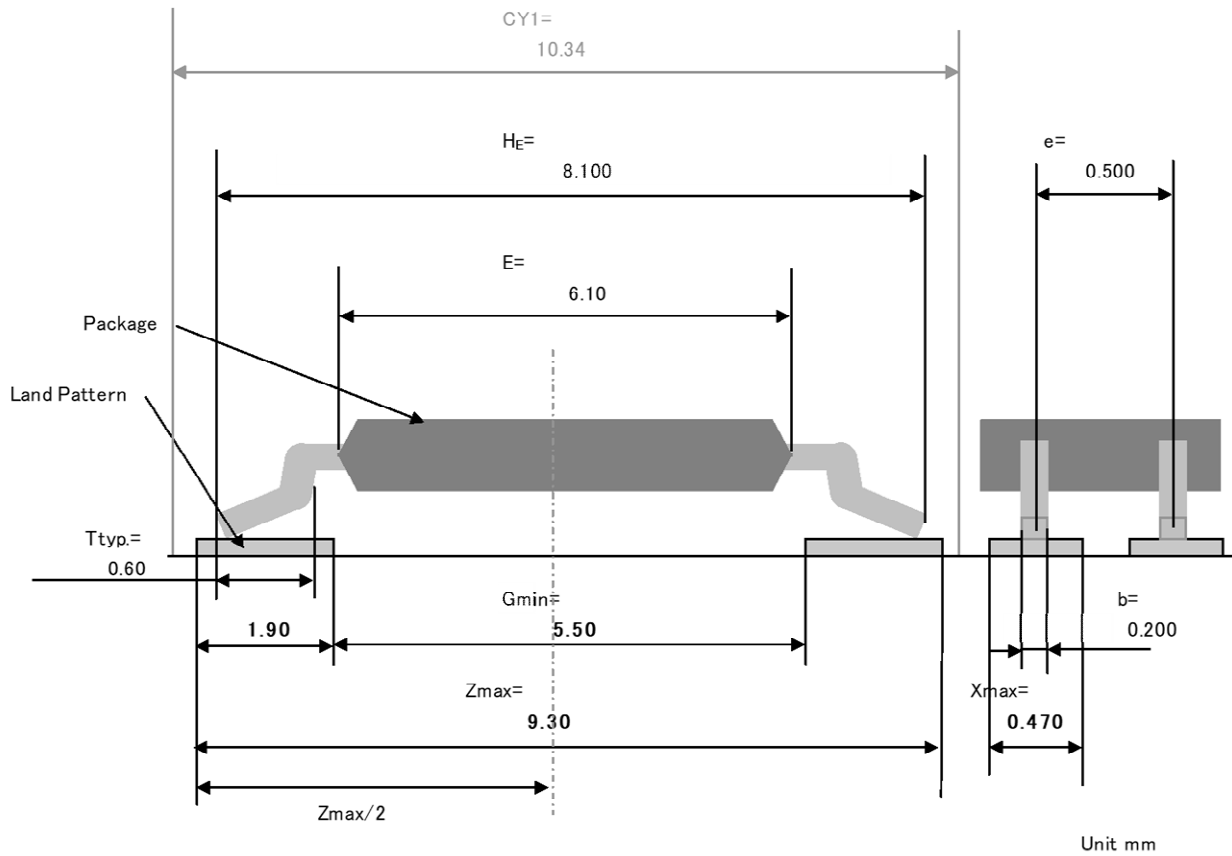

Figure 17. Reference of Land Pattern

The recommendation mounting method of THine device is reflow soldering.
 The reference pattern is using the calculation result on condition of reflow soldering.

Notes

This land pattern design is a calculated value based on JEITA ET-7501.
 Please take into consideration in an actual substrate design about enough the ease of mounting, the intensity of connection, the density of mounting, and the solder paste used, etc... The optimal land pattern size changes with these parameters. Please use the value shown by the land pattern as reference data.

Notices and Requests



1. The product specifications described in this material are subject to change without prior notice.
2. The circuit diagrams described in this material are examples of the application which may not always apply to the customer's design. THine Electronics, Inc. ("THine") is not responsible for possible errors and omissions in this material. Please note even if errors or omissions should be found in this material, THine may not be able to correct them immediately.
3. This material contains THine's copyright, know-how or other intellectual property rights. Copying, reverse-engineer or disclosing to third parties the contents of this material without THine's prior written permission is prohibited.
4. THINE ACCEPTS NO LIABILITY FOR ANY DAMAGE OR LOSS IN CONNECTION WITH ANY DISPUTE RELATING TO INTELLECTUAL PROPERTY RIGHTS BETWEEN THE USER AND ANY THIRD PARTY, ARISING OUT OF THIS PRODUCT, EXCEPT FOR SUCH DAMAGE OR LOSS IN CONNECTION WITH DISPUTES SUCCESSFULLY PROVED BY THE USER THAT SUCH DISPUTES ARE DUE SOLELY TO THINE. NOTE, HOWEVER, EVEN IN THE AFOREMENTIONED CASE, THINE ACCEPTS NO LIABILITY FOR SUCH DAMAGE OR LOSS IF THE DISPUTE IS CAUSED BY THE USER'S INSTRUCTION.
5. This product is not designed for applications that require extremely high-reliability/safety such as aerospace device, nuclear power control device, or medical device related to critical care, excluding when this product is specified for automotive use by THine and used it for that purpose. THine accepts no liability whatsoever for any damages, claims or losses arising out of the uses set forth above.
6. Despite our utmost efforts to improve the quality and reliability of the product, faults will occur with a certain small probability, which is inevitable to a semi-conductor product. Therefore, you are encouraged to have sufficiently fail-safe design principles such as redundant or error preventive design applied to the use of the product so as not to have our product cause any social or public damage.
7. This product may be permanently damaged and suffer from performance degradation or loss of mechanical functionality if subjected to electrostatic charge exceeding capacity of the ESD (Electrostatic Discharge) protection circuitry. Safety earth ground must be provided to anything in contact with the product, including any operator, floor, tester and soldering iron.
8. Please note that this product is not designed to be radiation-proof.
9. Testing and other quality control techniques are used to this product to the extent THine deems necessary to support warranty for performance of this product. Except where mandated by applicable law or deemed necessary by THine based on the user's request, testing of all functions and performance of the product is not necessarily performed.
10. This product must be stored according to storage method which is specified in this specifications. THine accepts no liability whatsoever for any damage or loss caused to the user due to any storage not according to above-mentioned method.
11. Customers are asked, if required, to judge by themselves if this product falls under the category of strategic goods under the Foreign Exchange and Foreign Trade Act in Japan and the Export Administration Regulations in the United States of America on export or transit of this product. This product is prohibited for the purpose of developing military modernization, including the development of weapons of mass destruction (WMD), and the purpose of violating human rights.
12. The product or peripheral parts may be damaged by a surge in voltage over the absolute maximum ratings or malfunction, if pins of the product are shorted by such as foreign substance. The damages may cause a smoking and ignition. Therefore, you are encouraged to implement safety measures by adding protection devices, such as fuses. THine accepts no liability whatsoever for any damage or loss caused to the user due to use under a condition exceeding the limiting values.
13. All patents or pending patent applications, trademarks, copyrights, layout-design exploitation rights or other intellectual property rights concerned with this product belong to THine or licensor(s) of THine. No license or right is granted to the user for any intellectual property right or other proprietary right now or in the future owned by THine or THine's licensor. The user must enter into a license agreement with THine or THine's licensor to be granted of such license or right.

THine Electronics, Inc.

<https://www.thine.co.jp>

Looking for pricing, stock, or lifecycle information?

Click below to explore more details on WIN SOURCE:

-  [View THC63LVDM83D-Z on WIN SOURCE](#)
-  [Thine Electronics, Inc. Information](#)

Optimize Your Supply Chain with WIN SOURCE Solutions

-  Global Sourcing Solution
-  Obsolete Management
-  Cost Control Management
-  Shortage Management
-  Alternative Solution
-  Excess Inventory Management