



SMT inductors

SIMID series, SIMID 2220-T

Series/Type: B82442T

Date: March 2022

SMD

Size 2220 (EIA) or 5650 (IEC)
Rated inductance 1 ... 10000 μ H
Rated current 46 ... 3510 mA



Construction

- Ferrite drum core
- Laser-welded winding
- Flame-retardant molding

Features

- Temperature range up to +150 °C
- Very high current handling capability
- High L values
- Qualified to AEC-Q200
- Suitable for lead-free reflow soldering as referenced in JEDEC J-STD 020D
- RoHS-compatible
- Halogen-free

Applications

- Filtering of supply voltages, coupling, decoupling
- DC/DC converters/switch-mode power supplies
- Automotive electronics
- Telecommunications
- Consumer electronics
- Industrial electronics

Terminals

- Base material CuSn6
- Layer composition Cu, Ag, Sn (lead-free) or Ni, Sn (lead-free)
- Electro-plated

Marking

- Marking on component:
 Manufacturer, letter "T", L value (in μ H),
 tolerance of L value (coded), date of manufacture (YWWD)
- Minimum data on reel:
 Manufacturer, ordering code, L value, quantity, date of packing

Delivery mode and packing unit

- 12-mm blister tape, wound on 330-mm \varnothing reel
- Packing unit: 1500 pcs./reel

SIMID 2220-T

SMD

Dimensional drawing

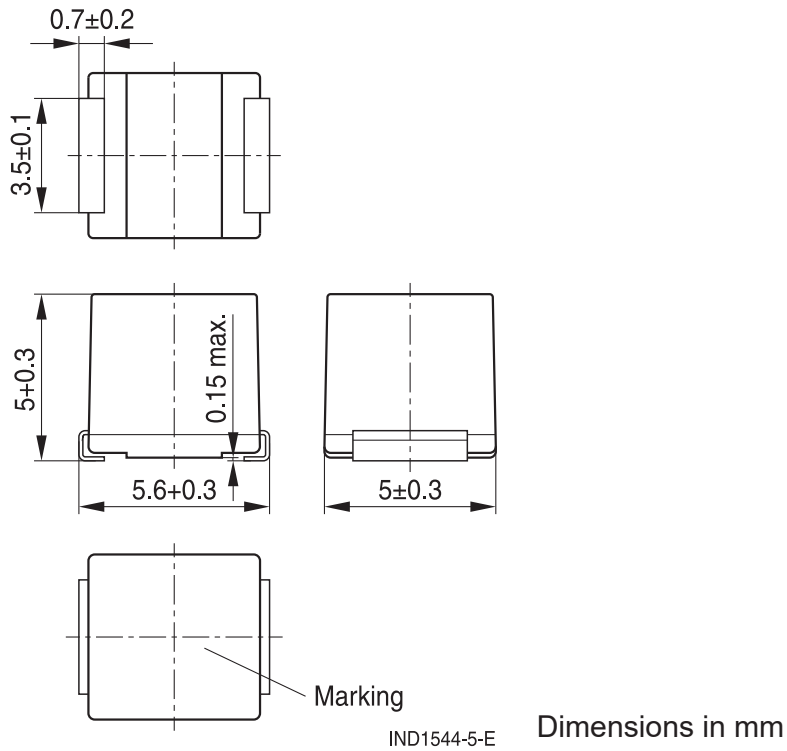

Soldering Area

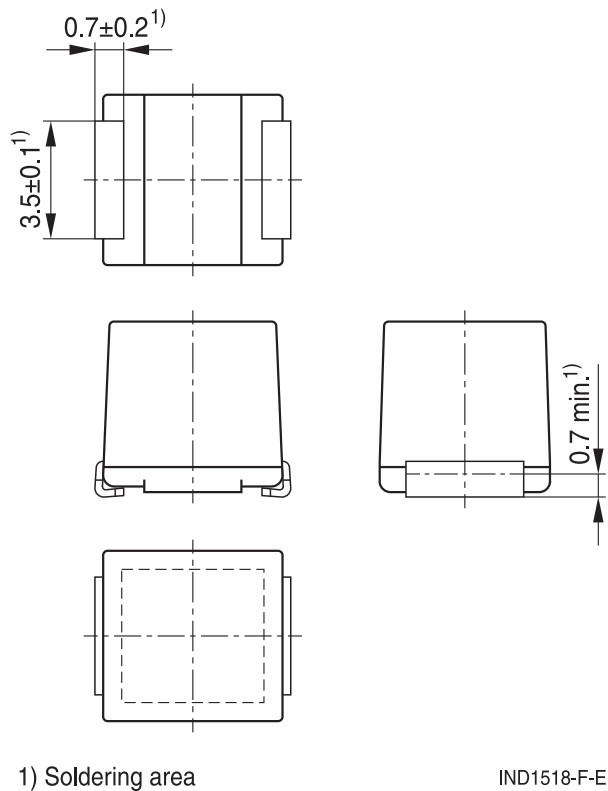

Layout recommendation

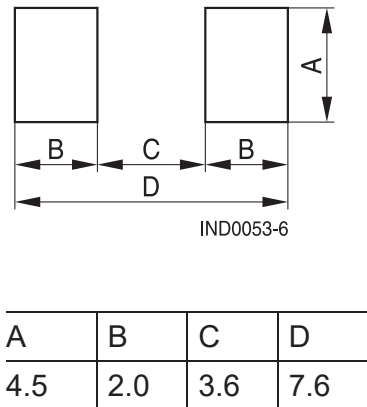

Dimensions in mm

SIMID 2220-T
SMD
Taping and packing

Blister tape

Reel

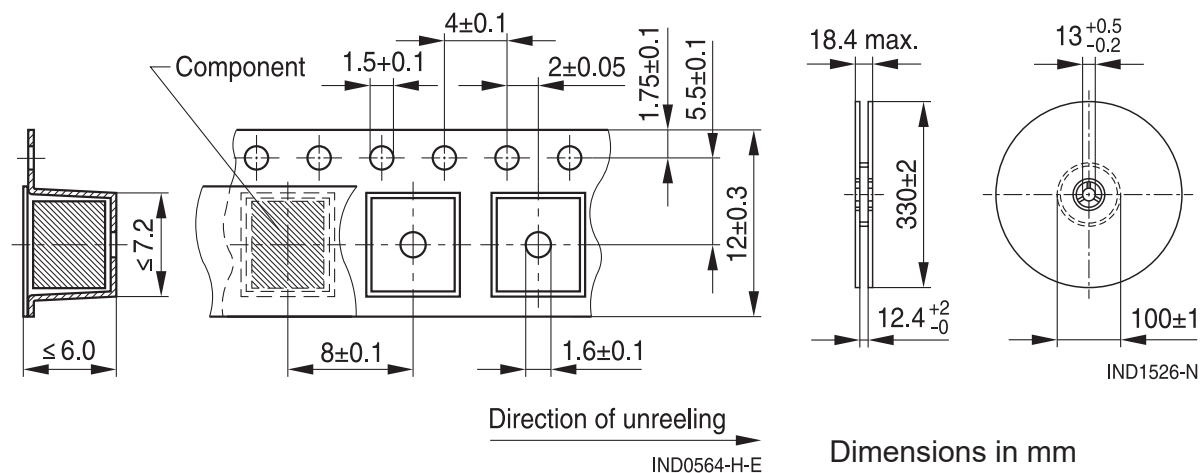
Technical data and measuring conditions

Rated inductance L_R	Measured with Agilent 4294A or equivalent at frequency f_L , 0.5 V, $+23 \pm 5 \text{ }^\circ\text{C}$
Inductance tolerance	$L_R < 100 \text{ } \mu\text{H}$: $\pm 10\%$ $L_R \geq 100 \text{ } \mu\text{H}$: $\pm 5\%$ or $\pm 10\%$
Q factor Q_{\min}	Measured with Agilent 4294A or equivalent at frequency f_Q , 0.5 V, $+23 \pm 5 \text{ }^\circ\text{C}$
Operating temperature range	$-55 \text{ }^\circ\text{C} \dots +150 \text{ }^\circ\text{C}$
Rated current I_{temp}	Maximum permissible DC with temperature increase of $\leq 65 \text{ K}$ at $+85 \text{ }^\circ\text{C}$
Saturation current $I_{\text{sat, min}}$	Maximum permissible DC with inductance decrease $\Delta L/L_0 \leq 10\%$, at $+23 \pm 5 \text{ }^\circ\text{C}$
Saturation current $I_{\text{sat, typ}}$	Maximum permissible DC with inductance decrease $\Delta L/L_0 \leq 30\%$, at $+23 \pm 5 \text{ }^\circ\text{C}$
Self-resonance frequency $f_{\text{res, min}}$	Measured with impedance analyzer Agilent 4294A / E4991A or equivalent at $+23 \pm 5 \text{ }^\circ\text{C}$
DC resistance R_{max}	Measured at $+23 \pm 5 \text{ }^\circ\text{C}$
Solderability (lead-free)	Sn95.5Ag3.8Cu0.7: $+(245 \pm 5) \text{ }^\circ\text{C}$, $(5 \pm 0.3) \text{ s}$ Wetting of soldering area $\geq 90\%$ (based on IEC 60068-2-58)
Resistance to soldering heat	$+260 \text{ }^\circ\text{C}$, 40 s (as referenced in JEDEC J-STD 020D)
Climatic category	55/150/56 (to IEC 60068-1)
Storage conditions	Mounted: $-55 \text{ }^\circ\text{C} \dots +150 \text{ }^\circ\text{C}$ Packaged: $-25 \text{ }^\circ\text{C} \dots +40 \text{ }^\circ\text{C}$, $\leq 75\% \text{ RH}$
Weight	Approx. 0.4 g

SMD
Characteristics and ordering codes

L_R μH	Q_{\min}	$f_L; f_Q$ MHz	$I_{\text{sat,typ}}$ mA	$I_{\text{sat,min}}$ mA	I_{temp} mA	R_{max} Ω	$f_{\text{res,min}}$ MHz	Ordering code ^{1) 2)}
1.0	15	7.96	9000	7330	3510	0.025	111	B82442T1102K000
1.2	15	7.96	8500	6030	3090	0.028	75	B82442T1122K000
1.5	15	7.96	7600	5480	3020	0.033	60	B82442T1152K000
1.8	15	7.96	6900	4890	2770	0.035	55	B82442T1182K000
2.2	15	7.96	6300	4820	2710	0.038	46	B82442T1222K000
2.7	15	7.96	5500	3980	2530	0.042	36	B82442T1272K000
3.3	15	7.96	5200	4010	2460	0.046	36	B82442T1332K000
3.9	15	7.96	4800	3310	2170	0.057	33	B82442T1392K000
4.7	15	7.96	4300	3450	1950	0.073	30	B82442T1472K000
5.6	15	7.96	4100	2780	1850	0.078	28	B82442T1562K000
6.8	15	7.96	3700	2770	1680	0.106	23	B82442T1682K000
8.2	15	7.96	3300	2330	1510	0.118	21	B82442T1822K000
10	15	2.52	2800	2280	1420	0.132	19	B82442T1103K000
12	15	2.52	2700	2160	1380	0.141	19	B82442T1123K000
15	15	2.52	2400	1870	1260	0.190	16	B82442T1153K000
18	15	2.52	2160	1780	1090	0.210	14	B82442T1183K000
22	15	2.52	2050	1590	1040	0.238	13	B82442T1223K000
27	15	2.52	1780	1400	880	0.307	11	B82442T1273K000
33	15	2.52	1700	1380	840	0.360	11	B82442T1333K000
39	15	2.52	1550	1190	720	0.456	9.0	B82442T1393K000
47	15	2.52	1350	1120	700	0.519	8.0	B82442T1473K000
56	15	2.52	1200	1010	600	0.679	7.5	B82442T1563K000
68	15	2.52	1050	900	570	0.781	7.0	B82442T1683K000
82	15	2.52	1000	830	540	0.832	6.6	B82442T1823K000
100	20	0.796	980	760	510	0.99	6.1	B82442T1104+000
120	20	0.796	900	670	440	1.29	5.3	B82442T1124+000
150	20	0.796	800	610	410	1.50	4.6	B82442T1154+000
180	20	0.796	720	550	350	1.96	4.2	B82442T1184+000
220	20	0.796	640	500	330	2.21	3.9	B82442T1224+000
270	20	0.796	560	450	290	2.95	3.5	B82442T1274+000
330	20	0.796	550	430	280	3.29	3.4	B82442T1334+000
390	20	0.796	520	390	260	3.70	3.0	B82442T1394+000
470	20	0.796	460	350	240	4.73	2.6	B82442T1474+000
560	20	0.796	410	320	220	5.21	2.4	B82442T1564+000
680	20	0.796	380	300	210	5.87	2.3	B82442T1684+000
820	20	0.796	360	270	170	7.86	2.2	B82442T1824+000
1000	30	0.252	310	246	150	9.5	1.8	B82442T1105+000

SMD

L_R μH	Q_{\min}	$f_L; f_Q$ MHz	$I_{\text{sat,typ}}$ mA	$I_{\text{sat,min}}$ mA	I_{temp} mA	R_{max} Ω	$f_{\text{res,min}}$ MHz	Ordering code ^{1) 2)}
1200	30	0.252	290	223	140	12.6	1.7	B82442T1125+000
1500	30	0.252	250	200	130	14.9	1.5	B82442T1155+000
1800	30	0.252	230	183	110	19.7	1.4	B82442T1185+000
2200	30	0.252	205	168	100	22.5	1.2	B82442T1225+000
2700	30	0.252	185	151	90	29.5	1.1	B82442T1275+000
3300	30	0.252	175	138	85	32.8	1.0	B82442T1335+000
3900	30	0.252	155	127	74	43.5	0.9	B82442T1395+000
4700	30	0.252	145	119	73	48.6	0.8	B82442T1475+000
5600	30	0.252	135	109	66	54.7	0.8	B82442T1565+000
6800	30	0.252	125	102	65	60.3	0.6	B82442T1685+000
8200	30	0.252	115	92	54	80.6	0.6	B82442T1825+000
10000	25	0.0796	110	81	46	112	0.5	B82442T1106+000

1) For Ni-barrier plated terminals replace the last two digits "00" by "50"

2) Replace the "+" in the ordering code

J: $\pm 5\%$

K: $\pm 10\%$

Closer tolerances and intermediate values on request.

Higher currents possible at temperatures $< T_R$ on request.

Sample kit available. Ordering code: B82442X002

For more information refer to chapter "Sample kits".

SMD

Impedance $|Z|$ versus frequency f
 measured with impedance analyzer Agilent 4294A/E4991A, typical values at +20 °C

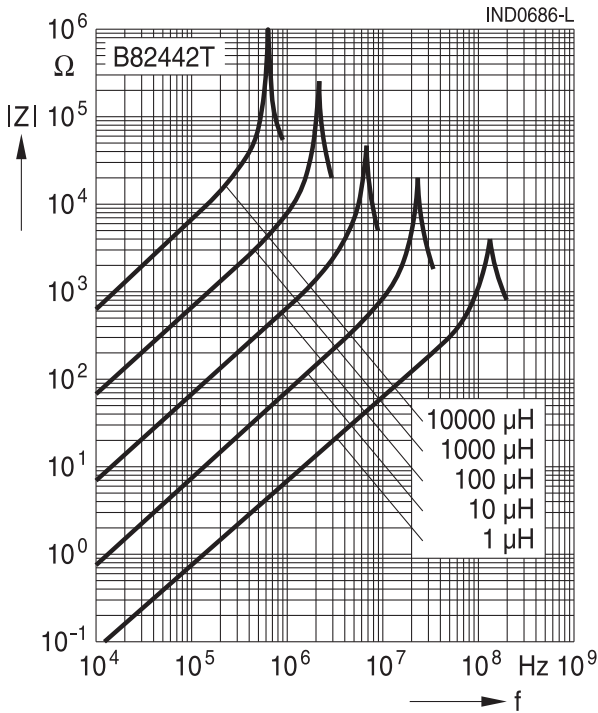

Inductance L versus DC load current I_{DC}
 measured with LCR meter Agilent 4285A, typical values at +20 °C

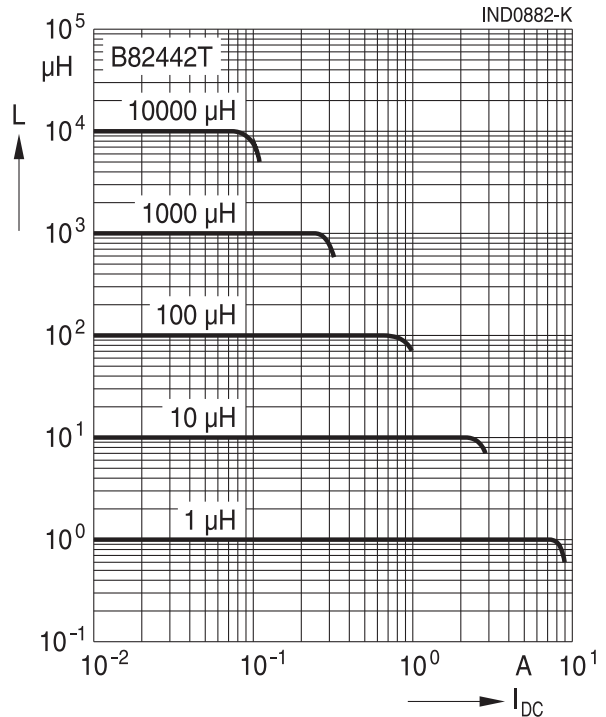

Q factor versus frequency f
 measured with impedance analyzer Agilent 4294A, typical values at +20 °C

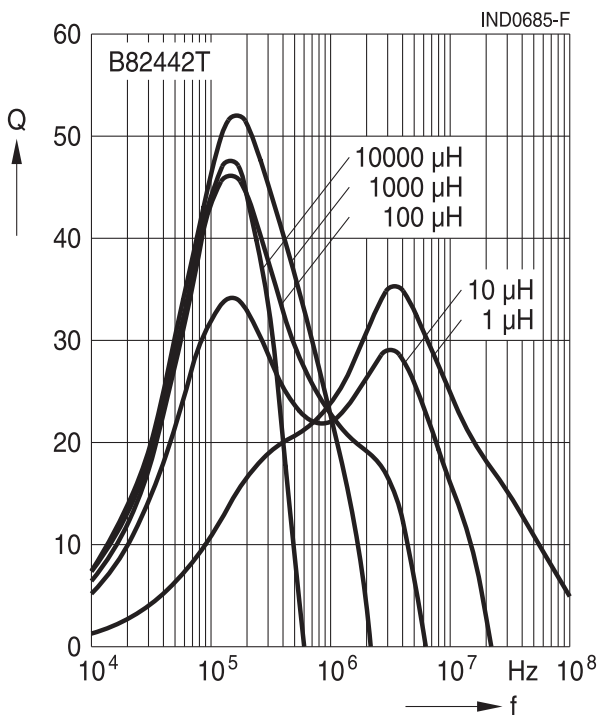

Current derating I_{op}/I_R versus ambient temperature T_A
 (rated temperature $T_R = +85$ °C)

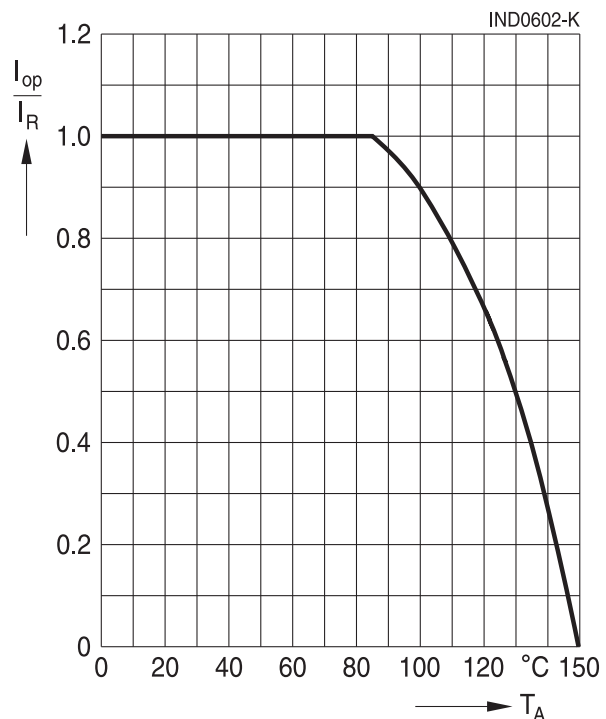

Cautions and warnings

- Please note the recommendations in our Inductors data book (latest edition) and in the data sheets.
 - Particular attention should be paid to the derating curves given there.
 - The soldering conditions should also be observed. Temperatures quoted in relation to wave soldering refer to the pin, not the housing.
- If the components are to be washed varnished it is necessary to check whether the washing varnish agent that is used has a negative effect on the wire insulation, any plastics that are used, or on glued joints. In particular, it is possible for washing varnish agent residues to have a negative effect in the long-term on wire insulation. Washing processes may damage the product due to the possible static or cyclic mechanical loads (e.g. ultrasonic cleaning). They may cause cracks to develop on the product and its parts, which might lead to reduced reliability or lifetime.
- The following points must be observed if the components are potted in customer applications:
 - Many potting materials shrink as they harden. They therefore exert a pressure on the plastic housing or core. This pressure can have a deleterious effect on electrical properties, and in extreme cases can damage the core or plastic housing mechanically.
 - It is necessary to check whether the potting material used attacks or destroys the wire, wire insulation, plastics or glue.
 - The effect of the potting material can change the high-frequency behaviour of the components.
 - Many coating materials have a negative effect (chemically and mechanically) on the winding wires, insulation materials and connecting points. Customers are always obligated to determine whether and to what extent their coating materials influence the component. Customers are responsible and bear all risk for the use of the coating material. TDK Electronics does not assume any liability for failures of our components that are caused by the coating material.
- Ceramics / Ferrites are sensitive to direct impact. This can cause the core material to flake, or lead to breakage of the core.
- Even for customer-specific products, conclusive validation of the component in the circuit can only be carried out by the customer.

Display of ordering codes for TDK Electronics products

The ordering code for one and the same product can be represented differently in data sheets, data books, other publications, on the company website, or in order-related documents such as shipping notes, order confirmations and product labels. **The varying representations of the ordering codes are due to different processes employed and do not affect the specifications of the respective products.** Detailed information can be found on the Internet under www.tdk-electronics.tdk.com/orderingcodes.

Important notes

The following applies to all products named in this publication:

1. Some parts of this publication contain **statements about the suitability of our products for certain areas of application**. These statements are based on our knowledge of typical requirements that are often placed on our products in the areas of application concerned. We nevertheless expressly point out **that such statements cannot be regarded as binding statements about the suitability of our products for a particular customer application**. As a rule, we are either unfamiliar with individual customer applications or less familiar with them than the customers themselves. For these reasons, it is always ultimately incumbent on the customer to check and decide whether a product with the properties described in the product specification is suitable for use in a particular customer application.
2. We also point out that **in individual cases, a malfunction of electronic components or failure before the end of their usual service life cannot be completely ruled out in the current state of the art, even if they are operated as specified**. In customer applications requiring a very high level of operational safety and especially in customer applications in which the malfunction or failure of an electronic component could endanger human life or health (e.g. in accident prevention or life-saving systems), it must therefore be ensured by means of suitable design of the customer application or other action taken by the customer (e.g. installation of protective circuitry or redundancy) that no injury or damage is sustained by third parties in the event of malfunction or failure of an electronic component.
3. **The warnings, cautions and product-specific notes must be observed.**
4. In order to satisfy certain technical requirements, **some of the products described in this publication may contain substances subject to restrictions in certain jurisdictions (e.g. because they are classed as hazardous)**. Useful information on this will be found in our Material Data Sheets on the Internet (www.tdk-electronics.tdk.com/material). Should you have any more detailed questions, please contact our sales offices.
5. We constantly strive to improve our products. Consequently, **the products described in this publication may change from time to time**. The same is true of the corresponding product specifications. Please check therefore to what extent product descriptions and specifications contained in this publication are still applicable before or when you place an order. We also **reserve the right to discontinue production and delivery of products**. Consequently, we cannot guarantee that all products named in this publication will always be available. The aforementioned does not apply in the case of individual agreements deviating from the foregoing for customer-specific products.
6. Unless otherwise agreed in individual contracts, **all orders are subject to our General Terms and Conditions of Supply**.



Important notes

7. **Our manufacturing sites serving the automotive business apply the IATF 16949 standard.** The IATF certifications confirm our compliance with requirements regarding the quality management system in the automotive industry. Referring to customer requirements and customer specific requirements (“CSR”) TDK always has and will continue to have the policy of respecting individual agreements. Even if IATF 16949 may appear to support the acceptance of unilateral requirements, we hereby like to emphasize that **only requirements mutually agreed upon can and will be implemented in our Quality Management System.** For clarification purposes we like to point out that obligations from IATF 16949 shall only become legally binding if individually agreed upon.
8. The trade names EPCOS, CarXield, CeraCharge, CeraDiode, CeraLink, CeraPad, CeraPlas, CSMP, CTVS, DeltaCap, DigiSiMic, ExoCore, FilterCap, FormFit, LeaXield, MiniBlue, MiniCell, MKD, MKK, ModCap, MotorCap, PCC, PhaseCap, PhaseCube, PhaseMod, PhiCap, PowerHap, PQSine, PQvar, SIFERRIT, SIFI, SIKOREL, SilverCap, SIMDAD, SiMic, SIMID, SineFormer, SIOV, ThermoFuse, WindCap, XieldCap are **trademarks registered or pending** in Europe and in other countries. Further information will be found on the Internet at www.tdk-electronics.tdk.com/trademarks.

Release 2020-06

Looking for pricing, stock, or lifecycle information?

Click below to explore more details on WIN SOURCE:

-  [View B82442T1223K000 on WIN SOURCE](#)
-  [EPCOS \(TDK\) Information](#)

Optimize Your Supply Chain with WIN SOURCE Solutions

-  Global Sourcing Solution
-  Obsolete Management
-  Cost Control Management
-  Shortage Management
-  Alternative Solution
-  Excess Inventory Management