

HFBR-1312TZ Transmitter

HFBR-2316TZ Receiver

1300 nm Fiber Optic Transmitter and Receiver



Data Sheet

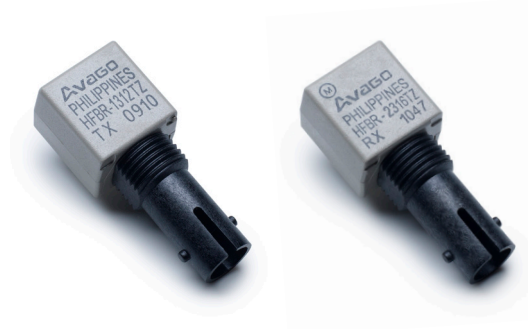

Description

The HFBR-1312TZ Transmitter and HFBR-2316TZ Receiver are designed to provide the most cost-effective 1300 nm fiber optic links for a wide variety of data communication applications from low-speed distance extenders up to SONET OC-3 signal rates. Pinouts identical to Avago HFBR-0400Z Series allow designers to easily upgrade their 820 nm links for farther distance. The transmitter and receiver are compatible with two popular optical fiber sizes: 50/125 μm and 62.5/125 μm diameter. This allows flexibility in choosing a fiber size. The 1300 nm wavelength is in the lower dispersion and attenuation region of fiber, and provides longer distance capabilities than 820 nm LED technology. Typical distance capabilities are 2 km at 125 MBd and 5 km at 32 MBd.

Features

- RoHS-compliant
- Low cost fiber optic link
- Signal rates over 155 megabaud
- 1300 nm wavelength
- Link distances up to 5 km
- Dual-in-line package panel-mountable ST* port
- Auto-insertable and wave-solderable
- Specified with 62.5/125 μm and 50/125 μm fiber
- Compatible with 820 nm Miniature Link Series
- Receiver also specified for SM cable spec (9/125 μm)

Applications

- Desktop links for high speed LANs
- Distance extension links
- Telecom switch systems
- TAXIchip® compatible

*ST is a registered trademark of AT&T Lightguide Cable Connectors

Transmitter

The HFBR-1312TZ fiber optic transmitter contains a 1300 nm InGaAsP light emitting diode capable of efficiently launching optical power into 50/125 μm and 62.5/125 μm diameter fiber. Due to the pin compatibility to the 820 nm Miniature Link Series, converting the driver circuit from a HFBR-14xxZ 820 nm transmitter to the HFBR-1312TZ requires the modification of only a few passive components.

HFBR-1312TZ Transmitter

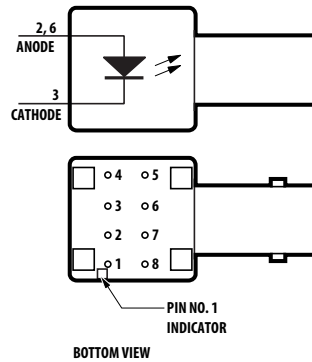

PIN	FUNCTION
1	N.C.
2	ANODE
3	CATHODE
4	N.C.
5	N.C.
6	ANODE
7*	N.C.
8	N.C.

* PIN 7 IS ELECTRICALLY ISOLATED FROM PINS 1, 4, 5, AND 8, BUT IS CONNECTED TO THE HEADER.

PINS 1, 4, 5, AND 8 ARE ISOLATED FROM THE INTERNAL CIRCUITRY, BUT ARE ELECTRICALLY CONNECTED TO EACH OTHER.

Receiver

The HFBR-2316TZ receiver contains an InGaAs PIN photodiode and a low-noise transimpedance preamplifier that operate in the 1300 nm wavelength region. The HFBR-2316TZ receives an optical signal and converts it to an analog voltage. The buffered output is an emitter-follower, with frequency response from DC to typically 125 MHz. Low-cost external components can be used to convert the analog output to logic compatible signal levels for a variety of data formats and data rates. Due to the pin compatibility to the 820 nm Miniature Link receiver HFBR-2416xxZ, converting from a 820nm to a 1300nm receiver circuit is realizable by replacing the HFBR-2416xxZ with the HFBR-2316TZ.

HFBR-2316TZ Receiver

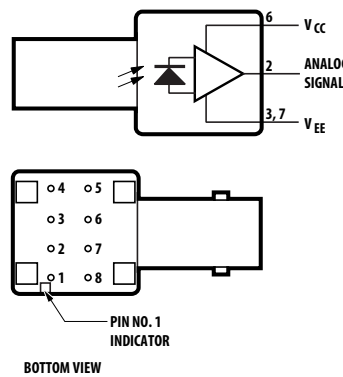

PIN	FUNCTION
1	N.C.
2	SIGNAL
3*	V _{EE}
4	N.C.
5	N.C.
6	V _{CC}
7*	V _{EE}
8	N.C.

* PINS 3 AND 7 ARE ELECTRICALLY CONNECTED TO THE HEADER.

PINS 1, 4, 5, AND 8 ARE ISOLATED FROM THE INTERNAL CIRCUITRY, BUT ARE ELECTRICALLY CONNECTED TO EACH OTHER.

Mechanical Dimensions

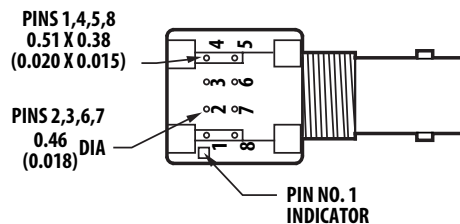
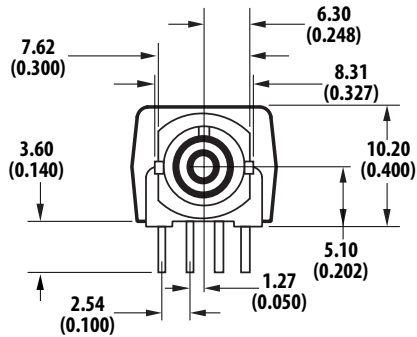
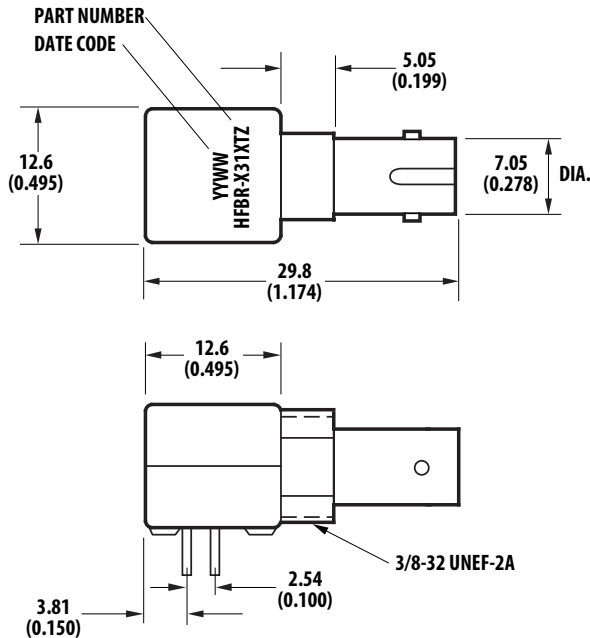

Dimensions in mm (inches)

Package Information

The transmitter and receiver are housed in a dual-in-line package made of high strength, heat resistant, chemically resistant, and UL V-0 flame retardant plastic. The package is auto-insertable and wave solderable for high volume production applications.

Note: The "T" in the product numbers indicates a Threaded ST connector (panel mountable), for both transmitter and receiver.

Handling and Design Information

When soldering, it is advisable to leave the protective cap on the unit to keep the optics clean. Good system performance requires clean port optics and cable ferrules to avoid obstructing the optical path. Clean compressed air is often sufficient to remove particles of dirt; methanol on a cotton swab also works well.

Recommended Chemicals for Cleaning/Degreasing

Alcohols (methyl, isopropyl, isobutyl)
Aliphatics (hexane, heptane)
Other (soap solution, naphtha)

Do not use partially halogenated hydrocarbons (such as 1.1.1 trichloroethane), ketones (such as MEK), acetone, chloroform, ethyl acetate, methylene dichloride, phenol, methylene chloride, or N-methylpyrrolidone. Also, Avago does not recommend the use of cleaners that use halogenated hydrocarbons because of their potential environmental harm.

Panel Mounting Hardware

The HFBR-4411Z kit consists of 100 nuts and 100 washers with dimensions as shown in Figure 1. These kits are available from Avago or any authorized distributor. Any standard size nut and washer will work, provided the total thickness of the wall, nut, and washer does not exceed 0.2 inch (5.1 mm).

When preparing the chassis wall for panel mounting, use the mounting template in Figure 2. When tightening the nut, torque should not exceed 0.8 N-m (8.0 in-lb).

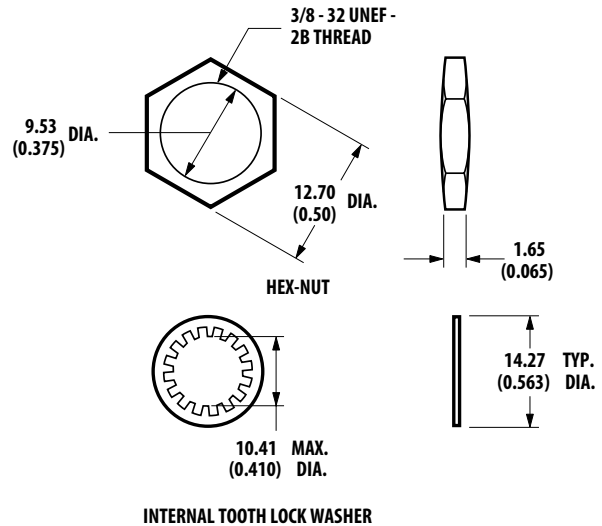

Figure 1. HFBR-4411Z mechanical dimensions

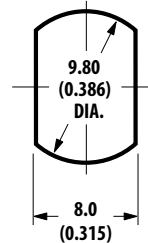

Figure 2. Recommended cut-out for panel mounting

Dimensions in mm (inches)

HFBR-1312TZ Transmitter Absolute Maximum Ratings

Parameter	Symbol	Min.	Max.	Unit	Reference
Storage Temperature	T_S	-55	85	°C	
Operating Temperature	T_A	-40	85	°C	
Lead Soldering Cycle Temperature			260	°C	Note 1
Lead Soldering Cycle Time			10	sec	
Forward Input Current DC	I_{FDC}		100	mA	
Reverse Input Voltage	V_R		1	V	

Notes:

1. 2.0 mm from where leads enter case.

CAUTION: The small junction sizes inherent to the design of this bipolar component increase the component's susceptibility to damage from electrostatic discharge (ESD). It is advised that normal static precautions be taken in handling and assembly of this component to prevent damage and/or degradation which may be induced by ESD.

HFBR-1312TZ Transmitter Electrical/Optical Characteristics

0 to 70°C unless otherwise specified

Parameter	Symbol	Min.	Typ. ^[2]	Max.	Unit	Condition	Ref.
Forward Voltage	V_F	1.1	1.4	1.7	V	$I_F = 75$ mA	Fig. 3
			1.5			$I_F = 100$ mA	
Forward Voltage Temperature Coefficient	$\Delta V_F / \Delta T$		-1.5		mV/°C	$I_F = 75 - 100$ mA	
Reverse Input Voltage	V_R	1	4		V	$I_R = 100$ μ A	
Center Emission Wavelength	λ_c	1270	1300	1370	nm		
Full Width Half Maximum	FWHM		130	185	nm		
Diode Capacitance	C_T		16		pF	$V_F = 0$ V, $f = 1$ MHz	
Optical Power Temperature Coefficient	$\Delta P_T / \Delta T$		-0.03		dB/°C	$I_F = 75 - 100$ mA DC	
Thermal Resistance	θ_{JA}		260		°C/W		Note 3

Notes:

2. Typical data are at $T_A = 25^\circ\text{C}$.
3. Thermal resistance is measured with the transmitter coupled to a connector assembly and mounted on a printed circuit board; $\theta_{JC} < \theta_{JA}$.

HFBR-1312TZ Transmitter Output Optical Power and Dynamic Characteristics

Parameter	Symbol	Min.	Typ. ^[1]	Max.	Unit	Condition		Ref.
						T _A	I _{F,peak}	
Peak Power 62.5/125 μm NA = 0.275	P _{T62}	-16.0	-14.0	-12.5	dBm	25°C	75 mA	Notes 2, 3, 4 Fig. 4
		-17.5		-11.5		0-70°C	75 mA	
		-15.5	-13.5	-12.0		25°C	100 mA	
		-17.0		-11.0		0-70°C	100 mA	
Peak Power 50/125 μm NA = 0.20	P _{T50}	-19.5	-17.0	-14.5	dBm	25°C	75 mA	Notes 2, 3, 4 Fig. 4
		-21.0		-13.5		0-70°C	75 mA	
		-19.0	-16.5	-14.0		25°C	100 mA	
		-20.5		-13.0		0-70°C	100 mA	
Optical Overshoot	OS		5	10	%	0-70°C	75 mA	Note 5 Fig. 5
Rise Time	t _r		1.8	4.0	ns	0-70°C	75 mA	Note 6 Fig. 5
Fall Time	t _f		2.2	4.0	ns	0-70°C	75 mA	Note 6 Fig. 5

Notes:

1. Typical data are at T_A = 25°C.
2. Optical power is measured with a large area detector at the end of 1 meter of mode stripped cable, with an ST* precision ceramic ferrule (MIL-STD-83522/13), which approximates a standard test connector. Average power measurements are made at 12.5 MHz with a 50% duty cycle drive current of 0 to I_{F,peak}; I_{F,average} = I_{F,peak}/2. Peak optical power is 3 dB higher than average optical power.
3. When changing from μW to dBm, the optical power is referenced to 1 mW (1000 μW).
Optical power P(dBm) = 10*log[P(μW)/1000μW].
4. Fiber NA is measured at the end of 2 meters of mode stripped fiber using the far-field pattern. NA is defined as the sine of the half angle, determined at 5% of the peak intensity point. When using other manufacturer's fiber cable, results will vary due to differing NA values and test methods.
5. Overshoot is measured as a percentage of the peak amplitude of the optical waveform to the 100% amplitude level. The 100% amplitude level is determined at the end of a 40 ns pulse, 50% duty cycle. This will ensure that ringing and other noise sources have been eliminated.
6. Optical rise and fall times are measured from 10% to 90% with 62.5/125 μm fiber. LED response time with recommended test circuit (Figure 3) at 25 MHz, 50% duty cycle.

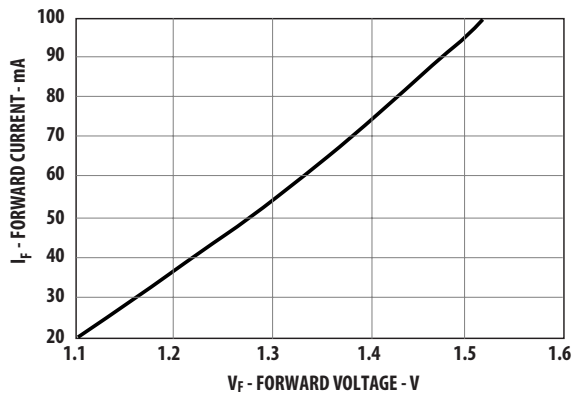

Figure 3. Typical forward voltage and current characteristics

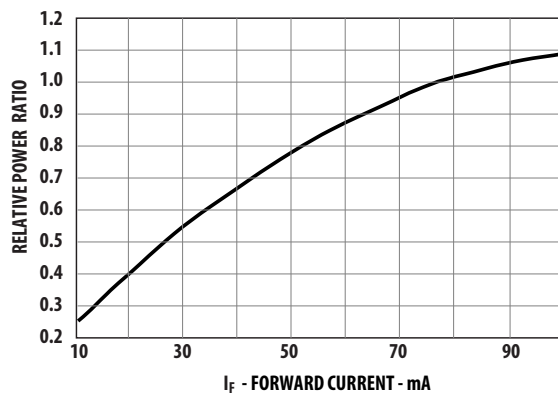

Figure 4. Normalized transmitter output power vs. forward current

HFBR-2316TZ Receiver Electrical/Optical and Dynamic Characteristics

0 to 70°C; $4.75\text{ V} < V_{CC} - V_{EE} < 5.25\text{ V}$; power supply must be filtered (see note 10).

Parameter	Symbol	Min.	Typ. ⁽¹⁾	Max.	Unit	Condition	Ref.
Responsivity	R_p 62.5 μm	6.5	13	19	mV/ μW	$\lambda_p = 1300\text{ nm}$, 50 MHz Multimode Fiber 62.5/125 μm	Note 2 Fig. 6, 10
	R_p 9 μm	8.5	17			Singlemode Fiber 9/125 μm	
RMS Output Noise Voltage	V_{NO}		0.4	0.59	mV _{RMS}	100 MHz Bandwidth, $P_R = 0\ \mu\text{W}$	Note 3 Fig. 7
				1.0	mV _{RMS}	Unfiltered Bandwidth $P_R = 0\ \mu\text{W}$	
Equivalent Optical Noise Input Power (RMS)	$P_{N,RMS}$		-45	-41.5	dBm	@ 100 MHz, $P_R = 0\ \mu\text{W}$	Note 3
Peak Input Optical Power	P_R		0.032	0.071	μW		
Output Resistance	R_O		30	-11.0	dBm	50 MHz, 1 ns PWD	Note 4 Fig. 8
				80	μW		
DC Output Voltage	$V_{O,DC}$	0.8	1.8	2.6	V	$V_{CC} = 5\text{ V}$, $V_{EE} = 0\text{ V}$ $P_R = 0\ \mu\text{W}$	
Supply Current	I_{CC}		9	15	mA	$R_{LOAD} = \infty$	
Electrical Bandwidth	BW_E	75	125		MHz	-3 dB electrical	Note 5
Bandwidth * Rise Time Product			0.41		Hz * s		Note 9
Electrical Rise, Fall Times, 10-90%	t_r, t_f		3.3	5.3	ns	$P_R = -15\text{ dBm peak}$, @ 50 MHz	Note 6 Fig. 9
Pulse-Width Distortion	PWD		0.4	1.0	ns	$P_R = -11\text{ dBm, peak}$	Note 4,7 Fig. 8
Overshoot			2		%	$P_R = -15\text{ dBm, peak}$	Note 8

Notes:

- Typical specifications are for operation at $T_A = 25^\circ\text{C}$ and $V_{CC} = +5\text{ V}_{DC}$.
- The test circuit layout should be in accordance with good high frequency circuit design techniques.
- Measured with a 9-pole "brick wall" low-pass filter [Mini-Circuits™, BLP-100*] with -3 dB bandwidth of 100 MHz.
- 11.0 dBm is the maximum peak input optical power for which pulse-width distortion is less than 1 ns.
- Electrical bandwidth is the frequency where the responsivity is -3 dB (electrical) below the responsivity measured at 50 MHz.
- The specified rise and fall times are referenced to a fast square wave optical source. Rise and fall times measured using an LED optical source with a 2.0 ns rise and fall time (such as the HFBR-1312TZ) will be approximately 0.6 ns longer than the specified rise and fall times.
E.g.: measured $t_{rf} \sim [(\text{specified } t_{rf})^2 + (\text{test source optical } t_{rf})^2]^{1/2}$.
- 10 ns pulse width, 50% duty cycle, at the 50% amplitude point of the waveform.
- Percent overshoot is defined as: $((V_{PK} - V_{100\%})/V_{100\%}) \times 100\%$. The overshoot is typically 2% with an input optical rise time $\leq 1.5\text{ ns}$.
- The bandwidth*risetime product is typically 0.41 because the HFBR-2316TZ has a second-order bandwidth limiting characteristic.
- The signal output is referred to V_{CC} and does not reject noise from the V_{CC} power supply. Consequently, the V_{CC} power supply must be filtered. The recommended power supply is +5 V on V_{CC} for typical usage with +5 V ECL logic. A -5 V power supply on V_{EE} is used for test purposes to minimize power supply noise.

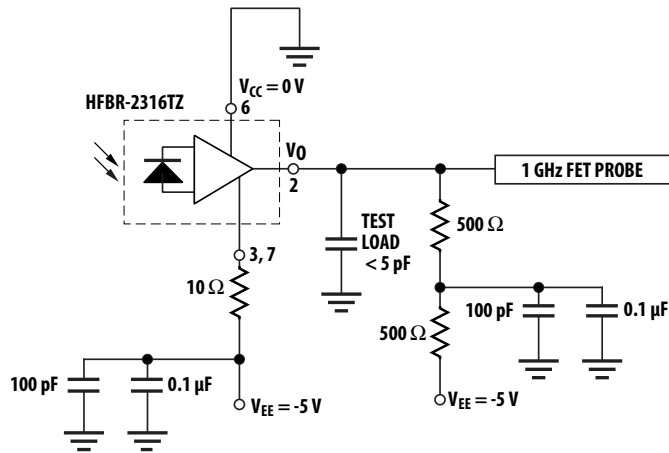

Figure 6. HFBR-2316TZ receiver test circuit

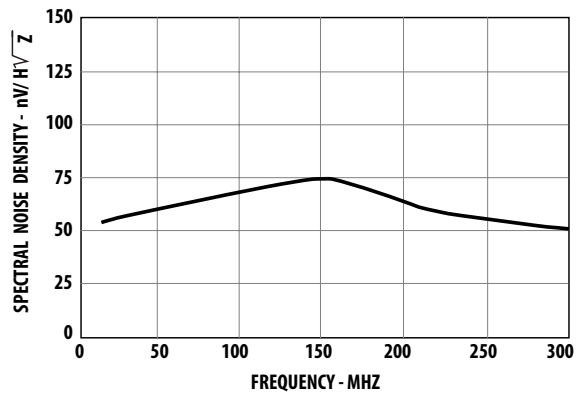

Figure 7. Typical output spectral noise density vs. frequency

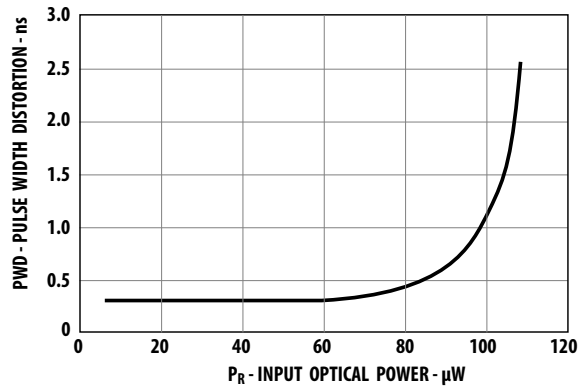

Figure 8. Typical pulse width distortion vs. peak input power.

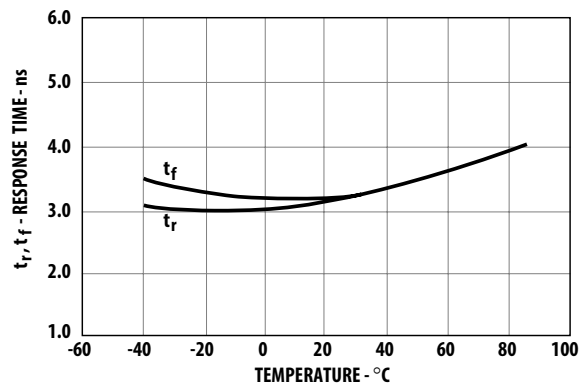

Figure 9. Typical rise and fall times vs. temperature

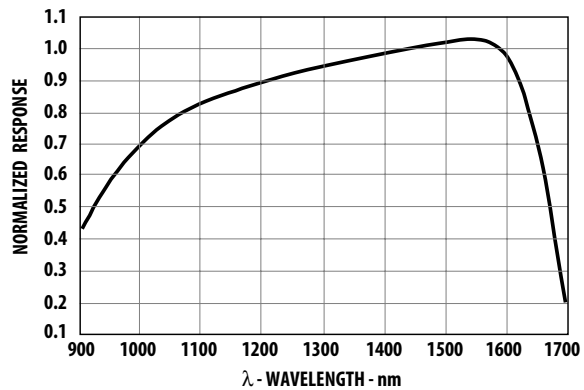

Figure 10. Normalized receiver spectral response

For product information and a complete list of distributors, please go to our web site: www.avagotech.com

Avago, Avago Technologies, and the A logo are trademarks of Avago Technologies in the United States and other countries. Data subject to change. Copyright © 2005-2013 Avago Technologies. All rights reserved. AV02-1500EN - October 10, 2013

AVAGO
TECHNOLOGIES

Looking for pricing, stock, or lifecycle information?

Click below to explore more details on WIN SOURCE:

 [View HFBR-0310Z on WIN SOURCE](#)

 [Broadcom Limited](#) Information

Optimize Your Supply Chain with WIN SOURCE Solutions

-  Global Sourcing Solution
-  Obsolete Management
-  Cost Control Management
-  Shortage Management
-  Alternative Solution
-  Excess Inventory Management