

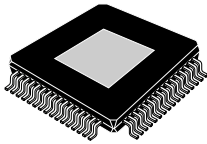

THE DATASHEET OF HFDA801A-VYT



4 x 80W digital input class-D automotive audio amplifier with Hi-Fi audio quality, advanced diagnostics, 2 MHz switching frequency and High Resolution Bandwidth



LQFP64 (exposed pad up)

Features

- AEC-Q100 qualification on going 
- Integrated 120 dB D/A conversion
- I²S and TDM digital input (up to 16 CH TDM)
- Selectable input sample rate frequency (44.1/48/96/192 kHz)
- Wide supply operating range: 4.5 V - 2518 V (5 V min at turn-on transition)
- PWM 2 MHz switching PWM:
 - Reduced size and cost of output LC
- High Resolution Bandwidth support:
 - Up to 40 kHz (I²S 96 kHz) with attenuation [0 dB, -2 dB]
 - Up to 80 kHz (I²S 192 kHz) with attenuation [0 dB, -2 dB]
- 4 I²C addresses
- 4 Ω, 2 Ω, 1 Ω driving with output channels parallelization
- MOSFET power outputs allowing high output power capability:
 - Typ 4 x 30 W /4 Ω @ 14.4 V, 1 kHz THD = 10%
 - Typ 4 x 25 W /4 Ω @ 14.4 V, 1 kHz THD = 1%
 - Typ 4 x 50 W /2 Ω @ 14.4 V 1 kHz THD =10 %
 - Typ 4 x 80 W /4 Ω @ 25V V, 1 kHz THD =10 %
- I²C full configurability and diagnostic:
 - 4 x Thermal warning and average junction temperature measurement on I²C (8 bits)
 - AC and DC diagnostic (independent of channel)
 - OCP protection scheme configurable (4 x OCP limit selectable)
 - Mute time configuration
 - DIM (digital impedance meter)
 - Feedback after filter configuration
- Capability to run complete diagnostic in play:
 - Short to GND/VCC
 - DC offset detector
- Extremely Low noise:
 - 13 μV A-weighted; 20 kHz (high gain) typ
- Very low THD:
 - 0.02% at 1 W 1 kHz on 4 and 2 Ω loads typ
 - 0.08% 20-20 kHz (full audio band) on 4 and 2 Ω loads (1 W)
- CD/Diag pin (3 selectable CD thresholds)
- Synchronization output pin (only with TDM input stream, on I²Sdata2)
- Channel independent Mute/Play/Gain selection/Diagnostic
- Real Time current monitor
- Open Load in play
- Battery load dump compatible (40 V)

Product status link		
HFDA801A		
Product summary		
Order code	Package	Packing
HFDA801A-VYY	LQFP64 (exp. pad up)	Tray
HFDA801A-VYT		Tape&Reel

- Immune to pop/tick noise at turn on /off, battery variations (inside the operative range), during diagnostic
- EMI compliance evaluated according to CISPR25
- Legacy (no I²C mode)
- Integrated short circuit protections
- ESD integrated protections (2 kV HBM, 500 V / 750 V corner CDM)
- LQFP64 exposed pad up package

Description

HFDA801A is the new ST class-D audio amplifier, specifically designed for automotive applications in the latest BCD technology. The HFDA801A integrates a 24-bits 120 dB DAC conversion, and features 2 MHz switching PWM class D output stage. This configuration enables the design of a compact and inexpensive application, reaching at the same time outstanding level of audio performances. HFDA801A supports wide band applications (80 kHz), with extremely low level of noise and low THD. Moreover it features the most complete diagnostic matrix, including full diagnostic in play to support the most demanding OEM requirements in terms of speaker control and system robustness/ reliability. HFDA801A supports start stop cranking down to 4.5 V (5 V at turn on) and it is housed in a very compact and thin LQFP 10x10 package. Thus the HFDA801A is suitable for any level of automotive application.

1 Block diagram and pins description

Figure 1. Block diagram

Figure 2. Pin connection diagram (top view)

Table 1. Pins list description

#	Pin	Function
1	OUT2+	Channel 2, half bridge plus, Output
2	OUT2+	Channel 2, half bridge plus, Output
3	GND2+	Channel 2, half bridge plus, Power Ground
4	GND2-	Channel 2, half bridge minus, Power Ground
5	OUT2-	Channel 2, half bridge minus, Output
6	OUT2-	Channel 2, half bridge minus, Output
7	FB2-	Channel 2, half bridge minus, Feedback
8	VCC2-	Channel 2, half bridge minus, Power Supply
9	VCC1-	Channel 1, half bridge minus, Power Supply
10	FB1-	Channel 1, half bridge minus, Feedback
11	OUT1-	Channel 1, half bridge minus, Output

#	Pin	Function
12	OUT1-	Channel 1, half bridge minus, Output
13	GND1-	Channel 1, half bridge minus, Power Ground
14	GND1+	Channel 1, half bridge plus, Power Ground
15	OUT1+	Channel 1, half bridge plus, Output
16	OUT1+	Channel 1, half bridge plus, Output
17	VCC1+	Channel 1, half bridge plus, Power Supply
18	FB1+	Channel 1, half bridge plus, Feedback
19	Enable	Enable pin
20	ADDSEL	Address selection pin, input
21	DGnd	Digital ground
22	SRGnd	Power management ground 1
23	DVdd	Digital Power Supply
24	L1	Power management inductor side1
25	L2	Power management inductor side2
26	LSGnd	Power management ground 2
27	V5V	Internal 5V supply
28	D1V8SVR	Positive digital supply V(SVR)+0.9 V (Internally generated)
29	DGSVR	Negative digital supply V(SVR)-0.9 V (Internally generated)
30	Vboost	Internal boost supply
31	FB3+	Channel 3, half bridge plus, Feedback
32	VCC3+	Channel 1, half bridge plus, Power Supply
33	OUT3+	Channel 3, half bridge plus, Output
34	OUT3+	Channel 3, half bridge plus, Output
35	GND3+	Channel 3, half bridge plus, Power Ground
36	GND3-	Channel 3, half bridge minus, Power Ground
37	OUT3-	Channel 3, half bridge minus, Output
38	OUT3-	Channel 3, half bridge minus, Output
39	FB3-	Channel 3, half bridge minus, Feedback
40	VCC3-	Channel 3, half bridge minus, Power Supply
41	VCC4-	Channel 4, half bridge minus, Power Supply
42	FB4-	Channel 4, half bridge minus, Feedback
43	OUT4-	Channel 4, half bridge minus, Output
44	OUT4-	Channel 4, half bridge minus, Output
45	GND4-	Channel 4, half bridge minus, Power Ground
46	GND4+	Channel 4, half bridge plus, Power Ground
47	OUT4+	Channel 4, half bridge plus, Output
48	OUT4+	Channel 4, half bridge plus, Output
49	VCC4+	Channel 4, half bridge plus, Power Supply
50	FB4+	Channel 4, half bridge plus, Feedback
51	CD/Diag	Clipping detector and diagnostic output pin
52	I2CClk	I2C Clock

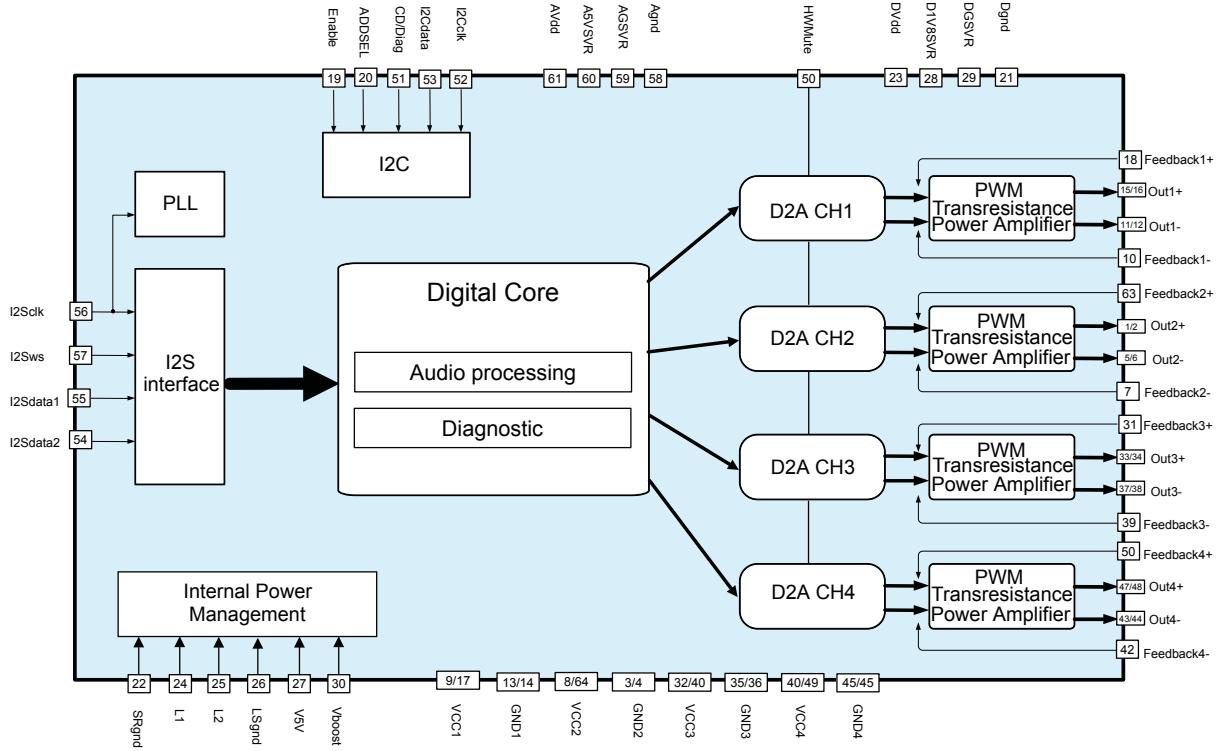
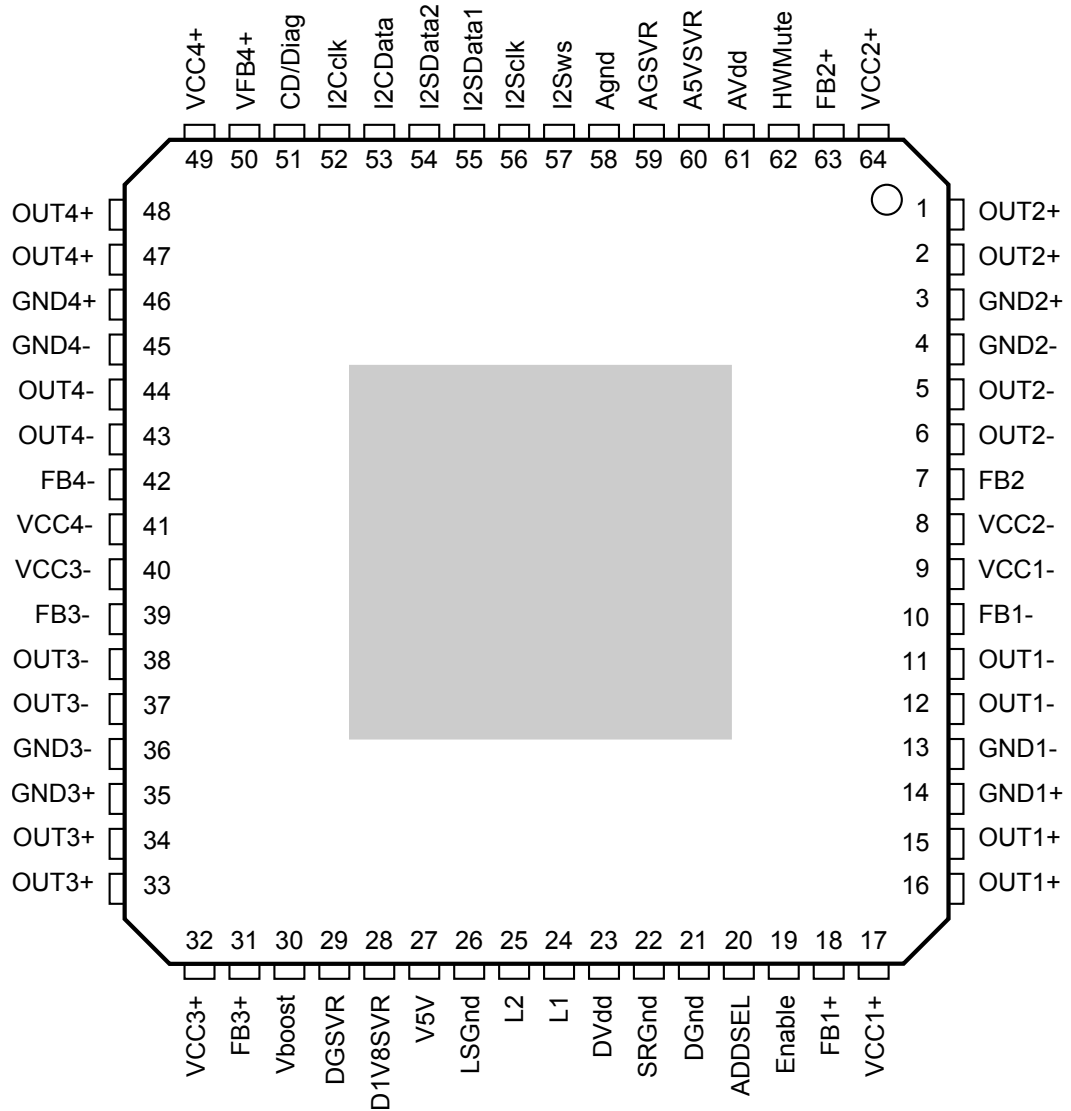
#	Pin	Function
53	I2CData	I2C Data
54	I2SData2	I2S/TDM Data input 2
55	I2SData1	I2S/TDM Data input 1
56	I2Sclk	I2S/TDM Clock input
57	I2Sws	I2S/TDM Sync input
58	Agnd	Analog ground
59	AGSVR	Negative Analog Supply V(SVR)-2.5 V (Internally generated) ⁽¹⁾
60	A5VSVR	Positive Analog Supply V(SVR)+2.5 V (Internally generated)
61	AVdd	Analog supply
62	HWMute	Hardware mute pin
63	FB2+	Channel 2, half bridge plus, Feedback
64	VCC2+	Channel 2, half bridge plus, Power Supply

1. Internal circuit output pin: not to be controlled externally. AMR not applicable.

2 Electrical specifications

2.1 Absolute maximum ratings

Table 2. Absolute maximum ratings

Symbol	Parameter	Value	Unit
VCC	DC supply voltage	-0.3 to 32	V
[V _{CC(x)+} , V _{CC(x)-} , A _{VDD} , D _{VDD}]	Transient supply voltage for t = 100 ms ⁽¹⁾	-0.3 to 40	V
GND _{max}	Ground pin voltage difference	-0.3 to 0.3	V
[GND _{(x)+} , GND _{(x)-} , A _{GND} , D _{GND} , SR _{GND} , LS _{GND}]			
FB _{(x)+} , FB _{(x)-}	Feedback pin	-0.3 to 32	V
OUT _{(x)+} , OUT _{(x)-}	Output pin	-0.3 to 32	V
L1	Internal Regulator pin	-0.3 to 32	V
L2	Internal Regulator pin	-0.3 to 40	V
I ² C _{data} , I ² C _{clk}	I ² C bus pins voltage	-0.3 to 5.5	V
I ² S _{data1} , I ² S _{data2} , I ² S _{clk} , I ² S _{WS}	I ² S bus pins voltage	-0.3 to 5.5	V
Enable	Enable pin voltage	-0.3 to 5.5	V
CD/Diag	CD/DIAG pin	-0.3 to 5.5	V
HWMute	Hardware Mute	-0.3 to 5.5	V
T _{amb}	Ambient operating temperature	-40 to 105	°C
T _{stg} , T _j	Storage and junction temperature	-55 to 150	°C
ESD _{HBM}	ESD protection HBM ⁽²⁾	2000	V
ESD _{CDM}	ESD protection CDM ⁽²⁾	500	V

1. Ramp time $T_r = 2 \text{ ms}$

2. Definition according to the international standard

2.2 Thermal data

Table 3. Thermal data

Symbol	Parameter	Value	Unit
R _{thjc}	R _{th} junction to case ⁽¹⁾	1.26	°C/W

1. Top Cold Plate as per Jedec best practice guidelines (JESD51) in contact with package top side (e-pad). Ambient temperature set to 85°C.

3 General description

HFDA801A is a fully digital single chip class-D amplifier with high immunity to the demodulation filter effects. The high integration level and the on-board signal processing allow excellent audio performance to be achieved. Thanks to the digital input and to the feedback strategy in the power stage, HFDA801A makes the amplifier immune from the output filter components non-linearity. The number and size of the external components are minimized.

HFDA801A includes: digital I²C and I²S interfaces, internal 24 bits DAC conversion, digital signal processing for interpolation and noise shaping, innovative self-diagnostic functions and automatic detection of wrong load connections or variation of the load, internal PLL for a clock generation. Moreover HFDA801A provides a breakthrough innovative digital impedance-meter which can communicate via I²C the output load value.

3.1 Feedback topology and switching frequency

HFDA801A adopts an innovative feedback topology, where the LC filter is included in the feedback loop making the amplifier highly insensitive to the characteristics of such demodulation circuit. This solution optimizes the system performance in terms of THD and frequency response in any load condition.

Regardless of the big phase shifting introduced by the output filter the device shows an adequate phase margin for any load condition. The system stability has been designed considering:

- PWM switching variation (from 2.1 MHz to 2.3 MHz)
- Silicon temperature variation (from -40 to 150 °C)
- Load variation (both inductive and capacitive considered)
- LC demodulator filter variation and tolerance
- Voltage supply variation (from 4.5 to 2518 V)
 - Minimum Supply Voltage level during Turn-On transition = 5 V

The system has been designed to guarantee a phase margin > 45 degrees for any working condition.

The new feedback topology assures a strong control of voltage and current across the load making the diagnostic load detection reliable. Moreover, this topology allows to reach exceptionally good values of output damping factor.

3.2 PWM frequencies

HFDA801A PWM frequency is well above the AM band, avoiding by architecture the EMC interference of PWM switching first harmonic. Moreover, this choice permits to optimize the size and cost of the external LC demodulation filter.

The PWM frequency depends on the I²S WS frequency as reported in the table below:

Table 4. PWM frequency relation with I²S WS frequency

WS Frequency [kHz]	Nominal PWM Frequency [MHz]
44.1	2.1168
48	2.304
96	2.304
192	2.304

3.3 Load possibilities

HFDA801A supports several load possibilities and configurations. The default configuration is suitable for a 4-channels application (front/rear – left/right): 4 x 4 Ω (up to 18 V).. By means of the I²C bus bit IB1-d7,d6 it is possible to choose a 2-channels solution with parallel outputs (left/right) or a 2.1 configuration for sub-woofer application.

Possible channel configurations:

- 4 x 4 Ω (up to 25 V)
- 4 x 2 Ω (up to 18 V)
- 2 x 1 Ω (through channels connected in parallel; limited to 18 V)
- 2 x 4 Ω + 1 x 2 Ω (through parallelized channels)

4 Package information

In order to meet environmental requirements, ST offers these devices in different grades of **ECOPACK** packages, depending on their level of environmental compliance. ECOPACK specifications, grade definitions and product status are available at: www.st.com. ECOPACK is an ST trademark.

4.1 LQFP64 (10x10x1.4 mm exp. pad up) package information

Figure 3. LQFP64 (10x10x1.4 mm exp. pad up) package outline

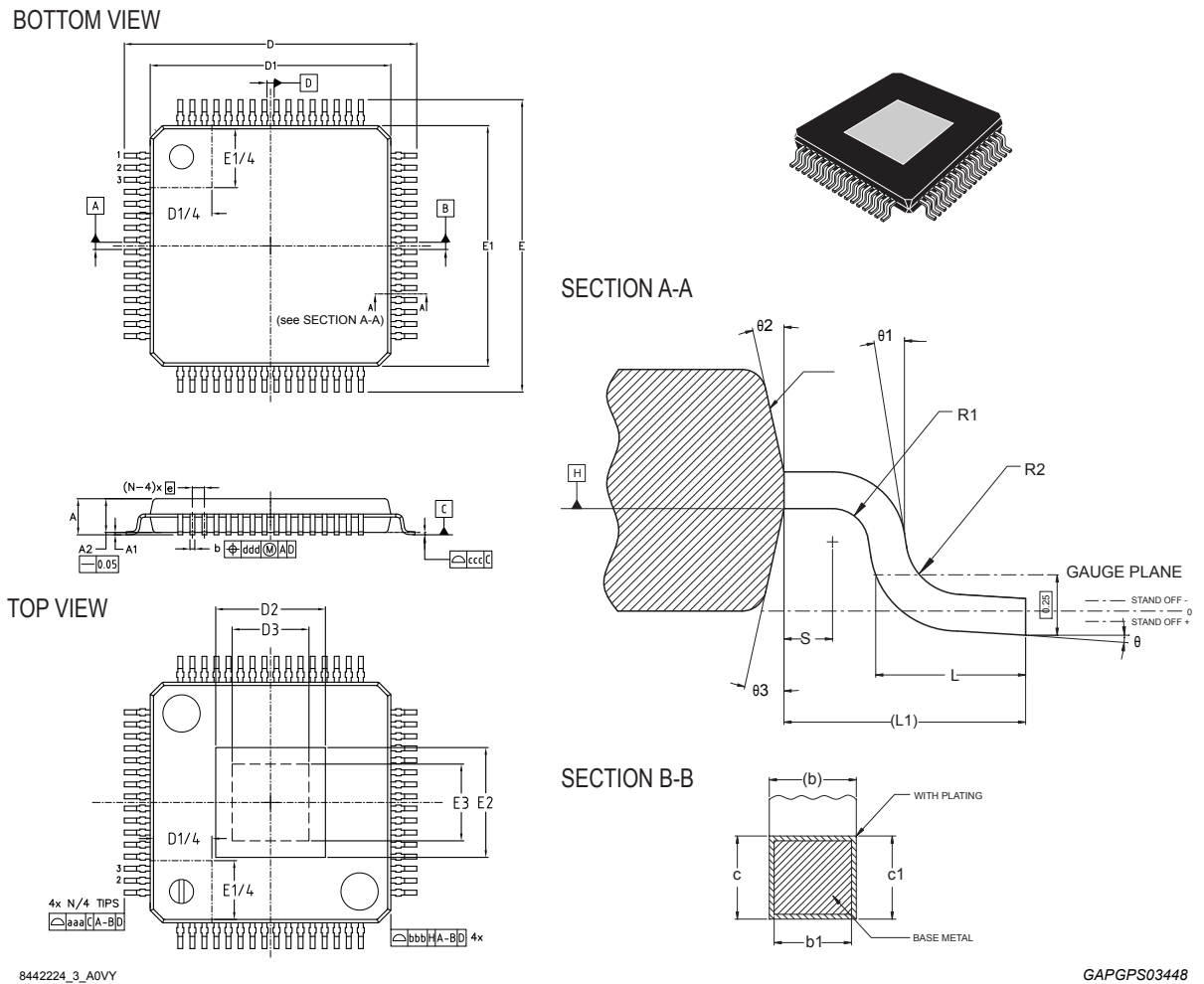
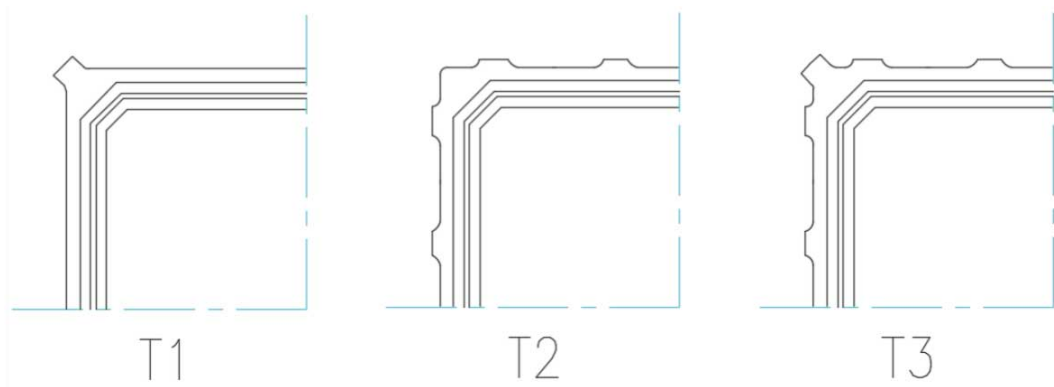

Table 5. LQFP64 (10x10x1.4 mm exp. pad up) package mechanical data

Symbol	Dimension in mm		
	Min.	Typ.	Max.
θ	0°	3.5°	6°
$\theta 1$	0°	9°	12°
$\theta 2$	11°	12°	13°
$\theta 3$	11°	12°	13°
A	-	-	1.49

Symbol	Dimension in mm		
	Min.	Typ.	Max.
A1	-0.04	-	0.04
A2	1.35	1.4	1.45
b	-	-	0.27
b1	0.17	0.2	0.23
c	0.09	-	0.2
c1	0.09	0.127	0.16
D	12.00 BSC		
D1 ⁽¹⁾⁽²⁾	10.00 BSC		
D2	See VARIATIONS		
D3	See VARIATIONS		
e	0.50 BSC		
E	12.00 BSC		
E1 ⁽¹⁾⁽²⁾	10.00 BSC		
E2	See VARIATIONS		
E3	See VARIATIONS		
L	0.45	0.6	0.75
L1	1.00 REF		
N	-	64	-
R1	0.08	-	-
R2	0.08	-	0.2
S	0.2	-	-
Tolerance of form and position			
aaa	-	0.2	-
bbb	-	0.2	-
ccc	-	0.08	-
ddd	-	0.08	-
VARIATIONS			
Pad option 6.0x6.0 (T1-T3)⁽³⁾			
D2	-	-	6.61
E2	-	-	6.61
D3	4.8	-	-
E3	4.8	-	-

1. Dimensions D1 and E1 do not include mold flash or protrusions. Allowable mold flash or protrusion is "0.25 mm" per side.
2. The Top package body size may be smaller than the bottom package size by as much as 0.15 mm.
3. Number, dimension and position of groves shown in [Figure 4](#) are for reference only.

Figure 4. Exposed-pad groove's shapes

Revision history

Table 6. Document revision history

Date	Version	Changes
15-Gen-2021	1	Initial release.

Contents

1	Block diagram and pins description	3
2	Electrical specifications	7
2.1	Absolute maximum ratings	7
2.2	Thermal data	7
3	General description	8
3.1	Feedback topology and switching frequency	8
3.2	PWM frequencies	8
3.3	Load possibilities	8
4	Package information	10
4.1	LQFP64 (10x10x1.4 mm exp. pad up) package information	10
	Revision history	13

List of tables

Table 1.	Pins list description	4
Table 2.	Absolute maximum ratings	7
Table 3.	Thermal data	7
Table 4.	PWM frequency relation with I ² S WS frequency	8
Table 5.	LQFP64 (10x10x1.4 mm exp. pad up) package mechanical data	10
Table 6.	Document revision history	13

List of figures

Figure 1.	Block diagram	3
Figure 2.	Pin connection diagram (top view).	4
Figure 3.	LQFP64 (10x10x1.4 mm exp. pad up) package outline	10
Figure 4.	Exposed-pad groove's shapes	12

IMPORTANT NOTICE – PLEASE READ CAREFULLY

STMicroelectronics NV and its subsidiaries (“ST”) reserve the right to make changes, corrections, enhancements, modifications, and improvements to ST products and/or to this document at any time without notice. Purchasers should obtain the latest relevant information on ST products before placing orders. ST products are sold pursuant to ST’s terms and conditions of sale in place at the time of order acknowledgement.

Purchasers are solely responsible for the choice, selection, and use of ST products and ST assumes no liability for application assistance or the design of Purchasers’ products.

No license, express or implied, to any intellectual property right is granted by ST herein.

Resale of ST products with provisions different from the information set forth herein shall void any warranty granted by ST for such product.

ST and the ST logo are trademarks of ST. For additional information about ST trademarks, please refer to www.st.com/trademarks. All other product or service names are the property of their respective owners.

Information in this document supersedes and replaces information previously supplied in any prior versions of this document.

© 2021 STMicroelectronics – All rights reserved

Mouser Electronics

Authorized Distributor

Click to View Pricing, Inventory, Delivery & Lifecycle Information:

[STMicroelectronics:](#)

[HFDA801A-VYT](#) [HFDA801A-VYY](#)

Looking for pricing, stock, or lifecycle information?

Click below to explore more details on WIN SOURCE:

- ⊖ [View HFDA801A-VYT on WIN SOURCE](#)
- ⊖ [STMicroelectronics](#) Information

Optimize Your Supply Chain with WIN SOURCE Solutions

- ✓ Global Sourcing Solution
- ✓ Obsolete Management
- ✓ Cost Control Management
- ✓ Shortage Management
- ✓ Alternative Solution
- ✓ Excess Inventory Management