



**THE DATASHEET OF
WW08XR820FTL**



APPROVAL SHEET

WR12, WR08, WR06, WR04

±1%, ±5%

General purpose chip resistors

Size 1206, 0805, 0603, 0402

Customer : _____

Approval No : _____

Issue Date : _____

Customer Approval :



FEATURE

1. High reliability and stability
2. Reduced size of final equipment
3. Lower assembly costs
4. Higher component and equipment reliability
5. Lead free products upon customer requested

APPLICATION

- Consumer electrical equipment
- Automotive application
- EDP, Computer application
- Telecom application

DESCRIPTION

The resistors are constructed in a high grade ceramic body (aluminum oxide). Internal metal electrodes are added at each end and connected by a resistive paste that is applied to the top surface of the substrate. The composition of the paste is adjusted to give the approximate resistance required and the value is trimmed to within tolerance by laser cutting of this resistive layer.

The resistive layer is covered with a protective coat. Finally, the two external end terminations are added. For ease of soldering the outer layer of these end terminations is a Tin (lead free) alloy.

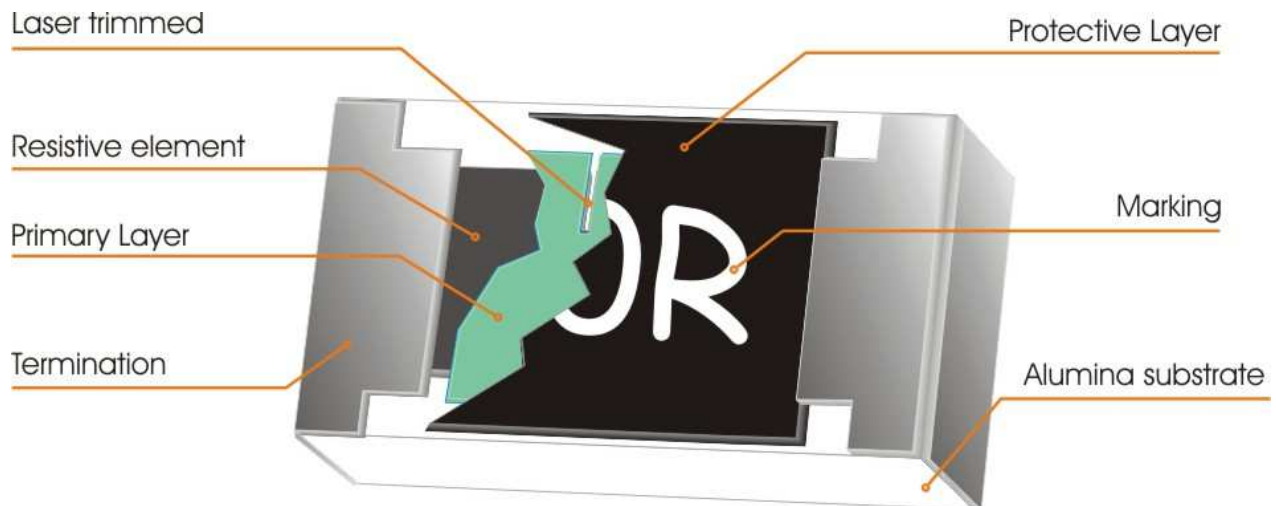

Fig 1. Construction of a Chip-R

**QUICK REFERENCE DATA**

Item	General Specification							
Series No.	WR12		WR08		WR06		WR04	
Size code	1206(3216)		0805(2012)		0603(1608)		0402(1005)	
Resistance Range	1Ω~10MΩ(±5% tolerance), 10Ω~1MΩ(±1% tolerance), Jumper							
Resistance Tolerance	±1% E96/E24	±5% E24	±1% E96/E24	±5% E24	±1% E96/E24	±5% E24	±1% E96/E24	±5% E24
TCR (ppm/°C)								
R≥1MΩ		≤ ± 200		≤ ± 200		≤ ± 200		-300~+500
1MΩ > R > 10Ω	≤ ± 100	≤ ± 200	≤ ± 100	≤ ± 200	≤ ± 100	≤ ± 200	≤ ± 100	≤ ± 200
R≤10Ω		-300~+500		-300~+500		-300~+500		-300~+500
Max. dissipation @ T _{amb} =70°C	1/4 W		1/8 W		1/10 W		1/16 W	
Max. Operation Voltage (DC or RMS)	200V		150V		50V		50V	
Max. Overload Voltage (DC or RMS)	400V		300V		100V		100V	
Climatic category	55/155/56							

Note :

- This is the maximum voltage that may be continuously supplied to the resistor element, see "IEC publication 60115-8"
- Max. Operation Voltage : So called RCWV (Rated Continuous Working Voltage) is determined by

$$RCWV = \sqrt{\text{Rated Power} \times \text{Resistance Value}}$$
or Max. RCWV listed above, whichever is lower.
- The resistance range 1~10Ω and 1M ~10MΩ with 1% tolerance please refer to WR12W / WR08W / WR06W series.
- The resistance of Jumper is defined <0.05Ω.

DIMENSIONS (unit : mm)

	WR12	WR08	WR06	WR04
L	3.10 ± 0.10	2.00 ± 0.10	1.60 ± 0.10	1.00 ± 0.05
W	1.60 ± 0.10	1.25 ± 0.10	0.80 ± 0.10	0.50 ± 0.05
T	0.60 ± 0.15	0.50 ± 0.15	0.45 ± 0.15	0.35 ± 0.05
Tb	0.45 ± 0.20	0.40 ± 0.20	0.30 ± 0.15	0.25 ± 0.10
Tt	0.50 ± 0.20	0.40 ± 0.20	0.30 ± 0.10	0.20 ± 0.10

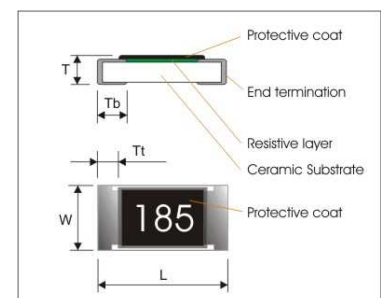
**MARKING**



Size \ Nr. Of digit of code\tolerance	$\pm 5\%$	$\pm 1\%$
1206 (3216)	3-digits marking	4-digits marking
0805 (2012)	3-digits marking	4-digits marking
0603 (1608)	3-digits marking	3-digits marking
0402(1005)	NO MARKING	

3-digits marking ($\pm 5\%$: 1206 & 0805 & 0603)

Each resistor is marked with a three digits code on the protective coating to designate the nominal resistance value. For values up to 9.1 the R is used as a decimal point. For values of 10.0 or greater the first 2 digits apply to the resistance value and third indicate the number of zeros to follow.

3-digits marking ($\pm 1\%$: 0603)

Nominal resistance	Description															
1.E-24 series	As 0603 WR06X $\pm 5\%$.															
2.E-96 series	The 1st two digit codes are referring to the CODE on the table, the 3rd code is the index of resistance value : $Y=10^{-2}$, $X=10^{-1}$, $A=10^0$, $B=10^1$, $C=10^2$, $D=10^3$, $E=10^4$, $F=10^5$ EX : 17.8 Ω =25X , 178 Ω =25A , 1K78 =25B 17K8=25C , 178K=25D , 1M78=25E															
3. Remark	There is no marking for the items are not under E-24 and E-96 series															
CODE	R_value	CODE	R_value	CODE	R_value	CODE	R_value	CODE	R_value	CODE	R_value	CODE	R_value	CODE	R_value	
01	100	13	133	25	178	37	237	49	316	61	422	73	562	85	750	
02	102	14	137	26	182	38	243	50	324	62	432	74	576	86	768	
03	105	15	140	27	187	39	249	51	332	63	442	75	590	87	787	
04	107	16	143	28	191	40	255	52	340	64	453	76	604	88	806	
05	110	17	147	29	196	41	261	53	348	65	464	77	619	89	825	
06	113	18	150	30	200	42	267	54	357	66	475	78	634	90	845	
07	115	19	154	31	205	43	274	55	365	67	487	79	649	91	866	
08	118	20	158	32	210	44	280	56	374	68	499	80	665	92	887	
09	121	21	162	33	215	45	287	57	383	69	511	81	681	93	909	
10	124	22	165	34	221	46	294	58	392	70	523	82	698	94	931	
11	127	23	169	35	226	47	301	59	402	71	536	83	715	95	953	
12	130	24	174	36	232	48	309	60	412	72	549	84	732	96	976	



4-digits marking (±1% : 1206/0805)

Each resistor is marked with a four digits code on the protective coating to designate the nominal resistance value. For values of <math><97.6\Omega</math> the R is used as a decimal point. For values of

Example

RESISTANCE	10 Ω	12 Ω	100 Ω	6800 Ω	47000 Ω
3-digits marking (1206 & 0805 & 0603 ±5%)	100	120	101	682	473
4-digits marking	10R0	12R0	1000	6801	4702

FUNCTIONAL DESCRIPTION

Product characterization

Standard values of nominal resistance are taken from the E24 series for resistors with a tolerance of ±5%, and E96 series for resistors with a tolerance of ±1%. The values of the E24/E96 series are in accordance with "IEC publication 60063"

Derating

The power that the resistor can dissipate depends on the operating temperature; see Fig.2

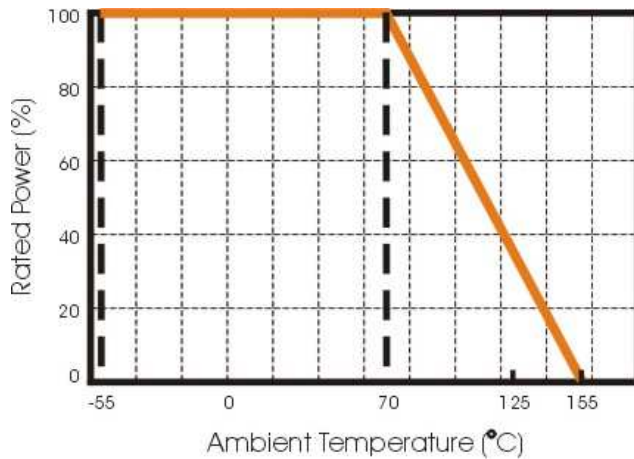

Figure 2 Maximum dissipation in percentage of rated power as a function of the ambient temperature for WR12X WR08X, WR06X, WR04X

MOUNTING

Due to their rectangular shapes and small tolerances, Surface Mountable Resistors are suitable for handling by automatic placement systems.

Chip placement can be on ceramic substrates and printed-circuit boards (PCBs).

Electrical connection to the circuit is by individual soldering condition.

The end terminations guarantee a reliable contact.



SOLDERING CONDITION

The robust construction of chip resistors allows them to be completely immersed in a solder bath of 260°C for 10 seconds. Therefore, it is possible to mount Surface Mount Resistors on one side of a PCB and other discrete components on the reverse (mixed PCBs).

Surface Mount Resistors are tested for solderability at 245°C during 3 seconds. The test condition for no leaching is 260°C for 30 seconds. Typical examples of soldering processes that provide reliable joints without any damage are given in Fig 3.

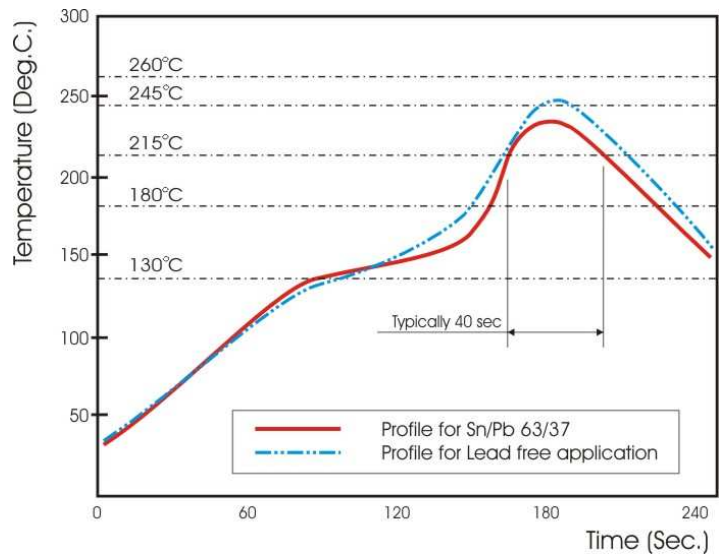

Fig 3. Infrared soldering profile for Chip Resistors

CATALOGUE NUMBERS

The resistors have a catalogue number starting with .

WR12	X	472_	J	T	L
Size code	Type code	Resistance code	Tolerance	Packaging code	Termination code
WR12 : 1206 WR08 : 0805 WR06 : 0603 WR04: 0402	X : Normal	E24 : 2 significant digits followed by no. of zeros and a blank 4.7Ω =4R7_ 10Ω =100_ 220Ω =221_ Jumper =000_ ("_" means a blank) E96 : 3 significant digits followed by no. of zeros 102Ω =1020 37.4KΩ =3742	F : ±1% J : ±5% P : Jumper	T : 7" Reeled taping Q : 10" Reeled taping G : 13" Reeled taping B : Bulk	L = Sn base (lead free)

WR12,WR08,WR06:

1. Reeled tape packaging : 8mm width paper taping 5000pcs per 7" reel, 10kpcs per 10" reel, 20kpcs per 13" reel.
2. Bulk packaging : 5000pcs per poly-bag

WR04:

1. Reeled tape packaging : 8mm width paper taping 10,000pcs per reel,
2. Bulk packaging : 10,000pcs per poly-bag

TEST AND REQUIREMENTS(JIS C 5201-1 : 1998)

Essentially all tests are carried out according to the schedule of IEC publication 115-8, category **LCT/UCT/56**(rated temperature range : **Lower Category Temperature, Upper Category Temperature**; damp heat, long term, 56 days). The testing also meets the requirements specified by EIA, EIAJ and JIS.

The tests are carried out in accordance with IEC publication 68, "Recommended basic climatic and mechanical robustness testing procedure for electronic components" and under standard atmospheric conditions according to IEC 60068-1, subclause 5.3. Unless otherwise specified, the following value supplied :

Temperature: 15°C to 35°C.

Relative humidity: 45% to 75%.

Air pressure: 86kPa to 106 kPa (860 mbar to 1060 mbar).

All soldering tests are performed with mildly activated flux.

TEST	PROCEDURE / TEST METHOD	REQUIREMENT	
		Resistor	0Ω
DC resistance Clause 4.5	DC resistance values measured at the test voltages specified below : <10Ω@0.1V, <100Ω@0.3V, <1KΩ@1.0V, <10KΩ@3V, <100KΩ@10V, <1MΩ@25V, <10MΩ@30V	Within the specified tolerance	<50mΩ
Temperature Coefficient of Resistance(T.C.R) Clause 4.8	Natural resistance change per change in degree centigrade. $\frac{R_2 - R_1}{R_1(t_2 - t_1)} \times 10^6 \text{ (ppm/°C)} \quad t_1 : 20^\circ\text{C} \pm 5^\circ\text{C} - 1^\circ\text{C}$ R ₁ : Resistance at reference temperature R ₂ : Resistance at test temperature	Refer to "QUICK REFERENCE DATA"	N/a
Short time overload (S.T.O.L) Clause 4.13	Permanent resistance change after a 5second application of a voltage 2.5 times RCWV or the maximum overload voltage specified in the above list, whichever is less.	ΔR/R max. ±(2%+0.10Ω)	<50mΩ
Resistance to soldering heat(R.S.H) IEC 60068-2-58:2004	Un-mounted chips completely immersed for 10±1second in a SAC solder bath at 255°C±5°C	ΔR/R max. ±(1%+0.05Ω) no visible damage	<50mΩ
Solderability IEC 60068-2-58:2004	Un-mounted chips completely immersed for 3±0.3 second in a SAC solder bath at 245°C±5°C	95% coverage min., good tinning and no visible damage	
Temperature cycling Clause 4.19	30 minutes at -55°C±3°C, 2~3 minutes at 20°C+5°C-1°C, 30 minutes at +155°C±3°C, 2~3 minutes at 20°C+5°C-1°C, total 5 continuous cycles	ΔR/R max. ±(1%+0.05Ω)	<50mΩ
Damp Heat (Load life in humidity) Clause 4.24	1000 +48/-0 hours, loaded with RCWV or V _{max} in humidity chamber controller at 40°C±2°C and 90~95% relative humidity, 1.5hours on and 0.5 hours off	10Ω≤R<1MΩ : ΔR/R max. ±(3%+0.10Ω) R<10Ω, R≥1MΩ : ΔR/R max. ±(5%+0.10Ω)	<50mΩ
Load Life(Endurance) Clause 4.25	1000 +48/-0 hours; loaded with RCWV or V _{max} in chamber controller 70±2°C, 1.5 hours on and 0.5 hours off	Ditto.	
Bending strength Clause 4.33	Resistors mounted on a 90mm glass epoxy resin PCB(FR4), bending once 3mm for 10sec, 5mm for WR04	No visual damaged, ΔR/R max. ±(1%+0.05Ω)	<50mΩ
Adhesion Clause 4.32	Pressurizing force: 5N, Test time: 10±1sec.	No remarkable damage or removal of the terminations	

TEST	PROCEDURE / TEST METHOD	REQUIREMENT	
		Resistor	0Ω
Insulation Resistance JISC5201-1:1998 Clause 4.6	Apply the maximum overload voltage (DC) for 1minute	$R \geq 10G\Omega$	
Dielectric Withstand Voltage JISC5201-1:1998 Clause 4.7	Apply the maximum overload voltage (AC) for 1 minute	No breakdown or flashover	

TEST CONDITION FOR JUMPER (0 Ω)

Item	WR12	WR08	WR06	WR04
Power Rating At 70°C	1/4W	1/8W	1/10W	1/16W
Resistance	MAX.50mΩ			
Rated Current	2A	1.5A	1A	1A
Peak Current	5A	3.5A	3A	1.5A
Operating Temperature	-55~155°C			



PACKAGING

Paper Tape specifications (unit :mm)

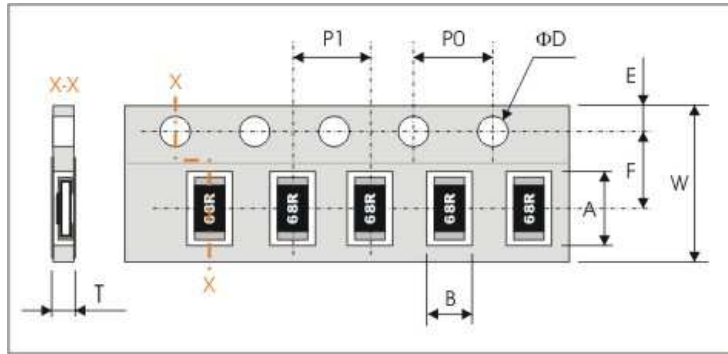

Series No.	A	B	W	F	E
WR12	3.60±0.20	2.00±0.20	8.00±0.30	3.50±0.20	1.75±0.10
WR08	2.40±0.20	1.65±0.20			
WR06	1.90±0.20	1.10±0.20			
WR04	1.20±0.10	0.70±0.10			
Series No.	P1	P0	ΦD	T	
WR12 / WR08	4.00±0.10	4.00±0.10	Φ1.50 ^{+0.1} _{-0.0}	Max. 1.0	
WR06				0.65±0.05	
WR04				0.40±0.05	

7" Reel dimensions

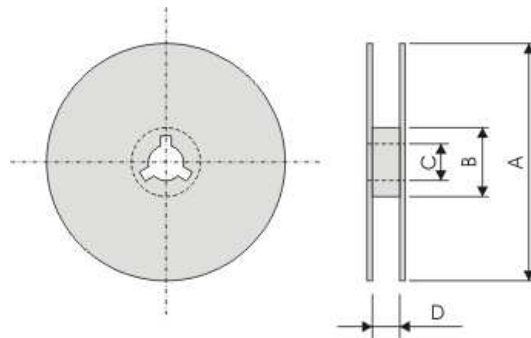

Symbol	A	B	C	D
(unit : mm)	Φ178.0±2.0	Φ60.0±1.0	13.0±0.2	9.0±0.5

Mouser Electronics

Authorized Distributor

Click to View Pricing, Inventory, Delivery & Lifecycle Information:

Walsin:

[WR06X1104FTL](#) [WR06X1204FTL](#) [WR06X1304FTL](#) [WR06X1604FTL](#) [WR06X3R90FTL](#) [WR06X4R70FTL](#)
[WR06X6R80FTL](#) [WR06X7R50FTL](#) [WR08X2004FTL](#) [WR08X2R20FTL](#) [WR08X3004FTL](#) [WR08X3R30FTL](#)
[WR08X4704FTL](#) [WR08X4R70FTL](#) [WR08X5104FTL](#) [WR08X5R60FTL](#) [WR08X8204FTL](#) [WR12X1005FTL](#)
[WR12X1R00FTL](#) [WR12X2204FTL](#) [WR12X2R00FTL](#) [WR12X2R20FTL](#) [WR12X2R40FTL](#) [WR12X4R70FTL](#)
[WR12X5R36FTL](#)

Looking for pricing, stock, or lifecycle information?

Click below to explore more details on WIN SOURCE:

- ⊖ [View WW08XR820FTL on WIN SOURCE](#)
- ⊖ [Walsin Technology Corporation Information](#)

Optimize Your Supply Chain with WIN SOURCE Solutions

- ✓ Global Sourcing Solution
- ✓ Obsolete Management
- ✓ Cost Control Management
- ✓ Shortage Management
- ✓ Alternative Solution
- ✓ Excess Inventory Management