



**THE DATASHEET OF
ABMM2-8.000MHZ-D1-T**



CERAMIC SMD CRYSTAL

ABMM2

Request Samples



Check Inventory



6.0 x 3.5 x 1.2 mm

RoHS/RoHS II Compliant

MSL Level = N/A



Features

- Suitable for RoHS compliant reflow
- Seam sealed ceramic package assures high reliability
- Available tight tolerance and stability

Applications

- Computers, Modems, Microprocessors
- Communication, Test equipment

Key Electrical Specifications

| Parameters | Min. | Typ. | Max. | Units | Notes |
|---|---------------------|--------------------------|---------|-------|--|
| Frequency Range | 7.3728 | | 100.000 | MHz | |
| Operation Mode | 7.3728– 30.000MHz | Fundamental | | | Standard |
| | 30.001 – 100.000MHz | 3 rd Overtone | | | Standard |
| | 30.001 – 50.000MHz | Fundamental | | | See options |
| Operating Temperature | -10 | | +60 | °C | See options |
| Storage Temperature | -40 | | +85 | °C | |
| Frequency Tolerance @ +25°C | -20 | | +20 | ppm | See options |
| Frequency Stability over the Operating Temperature (ref. to +25°C) | -20 | | +20 | ppm | See options |
| Equivalent series resistance (ESR) | See table 1 below | | | Ω | |
| Shunt capacitance (C0) | | | 7.0 | pF | |
| Load capacitance (CL) | | 18.0 | | pF | Standard (See options if other than STD) |
| Drive Level | | 100 | 500 | μW | |
| Aging | -2 | | +2 | ppm | @25°C±3°C First year |
| Insulation Resistance | 500 | | | MΩ | @ 100Vdc ± 15V |

Standard ESR

| Frequency (MHz) | ESR(Ω) max |
|---------------------------------------|------------|
| 7.3728 – 7.999 (Fund) | 140 |
| 8.000 – 10.000 (Fund) | 72 |
| 10.001 – 20.000 (Fund) | 50 |
| 20.001 – 50.000 (Fund) | 40 |
| 30.001 – 47.999 (3 rd OT) | 60 |
| 48.000 – 100.000 (3 rd OT) | 80 |



5101 Hidden Creek Ln Spicewood TX 78669
 Phone: 512-371-6159 | Fax: 512-351-8858
 For terms and conditions of sales, please visit:
www.abracon.com

REVISED: 07-31-24

ABRACON IS
 ISO9001-2015
 CERTIFIED

CERAMIC SMD CRYSTAL

ABMM2

Request Samples



Check Inventory



6.0 x 3.5 x 1.2 mm
RoHS/RoHS II Compliant
 MSL Level = N/A

Options and Part Identification (left blank if standard)

ABMM2- MHz - - - - - -

Frequency in MHz

Please specify the Frequency in MHz
 e.g. 16.000MHz

Load Capacitance (pF)

Please specify CL in pF (8 to 33pF) or S for series
 Please contact Abracon for other values

Custom ESR if other than standard

R
: Specify a value in Ω (e.g.: R40)

Freq. Tolerance

1: ± 10 ppm
 7: ± 15 ppm

Packaging

Blank: Bulk
 T: 1000pcs / reel
 T2: 250pcs / reel

Oscillation Mode

Blank: Standard mode
 F: Fundamental AT for Frequencies > 30.000MHz

Frequency Stability (ppm)

| Operating Temp. | ± 10 | ± 15 | ± 20 | ± 30 | ± 50 | ± 100 |
|-----------------|----------|----------|----------|----------|----------|-----------|
| 0°C ~ +50°C | A3 | - | A4 | A6 | - | - |
| -10°C ~ +50°C | B3 | - | B4 | B6 | - | - |
| -10°C ~ +60°C | C1 | C2 | Std | C6 | - | - |
| -20°C ~ +70°C | E1 | - | E2 | E6 | - | - |
| -40°C ~ +85°C | - | - | D1 | D6 | D5 | - |
| -40°C ~ +105°C | - | - | - | - | J5 | J10 |
| -40°C ~ +125°C | - | - | - | - | K5 | K10 |



5101 Hidden Creek Ln Spicewood TX 78669
 Phone: 512-371-6159 | Fax: 512-351-8858
 For terms and conditions of sales, please visit:
www.abracon.com

REVISED: 07-31-24

ABRACON IS
 ISO9001-2015
 CERTIFIED

CERAMIC SMD CRYSTAL

ABMM2

Request Samples



Check Inventory



6.0 x 3.5 x 1.2 mm
RoHS/RoHS II Compliant
 MSL Level = N/A



Mechanical Dimensions

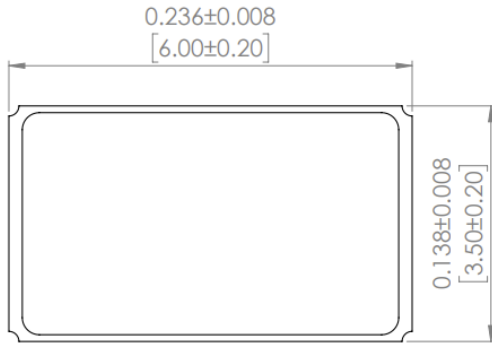

TOP VIEW

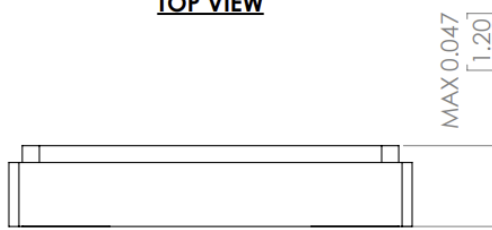

FRONT VIEW

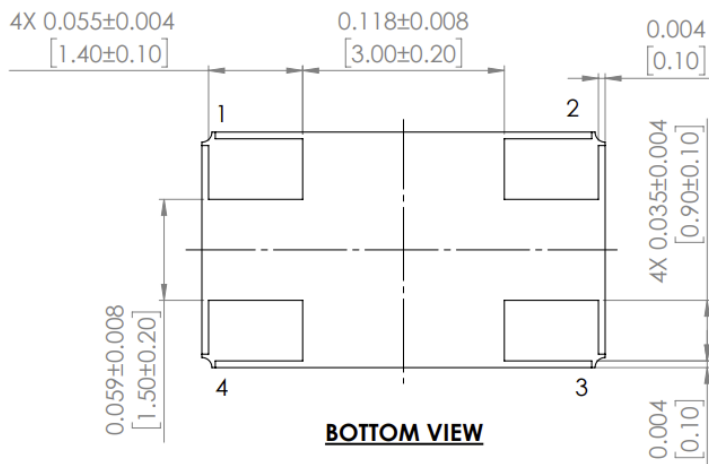

BOTTOM VIEW

RECOMMENDED LAND PATTERN

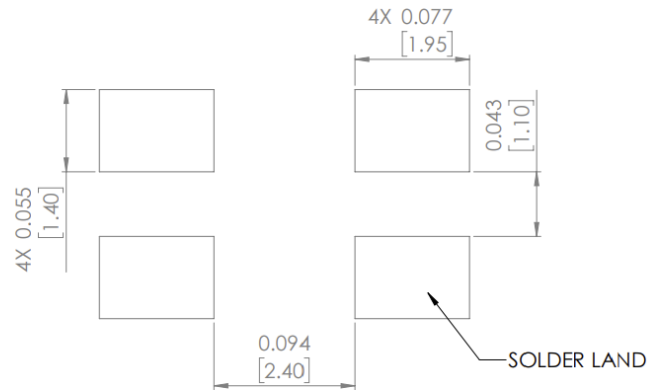

CIRCUIT

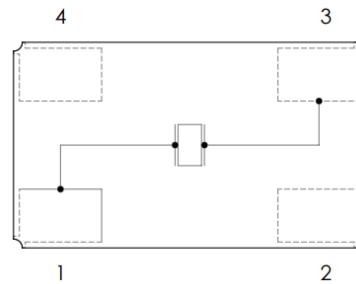

Note 1: Chamfer is not shown in illustration. A chamfer may appear on pad 1 or pad 4.

Note 2: A chamfer may be a rounded pad or diagonal corner.

Note 3: Pad 2 and pad 4 are connected to the metal lid. Please connect them to GND.

Dimensions: Inches [mm]



5101 Hidden Creek Ln Spicewood TX 78669
 Phone: 512-371-6159 | Fax: 512-351-8858
 For terms and conditions of sales, please visit:
www.abracon.com

REVISED: 07-31-24

ABRACON IS
 ISO9001-2015
 CERTIFIED

CERAMIC SMD CRYSTAL

ABMM2

Request Samples



Check Inventory



6.0 x 3.5 x 1.2 mm
RoHS/RoHS II Compliant
MSL Level = N/A



Reflow Profile [JEDEC J-STD-020]

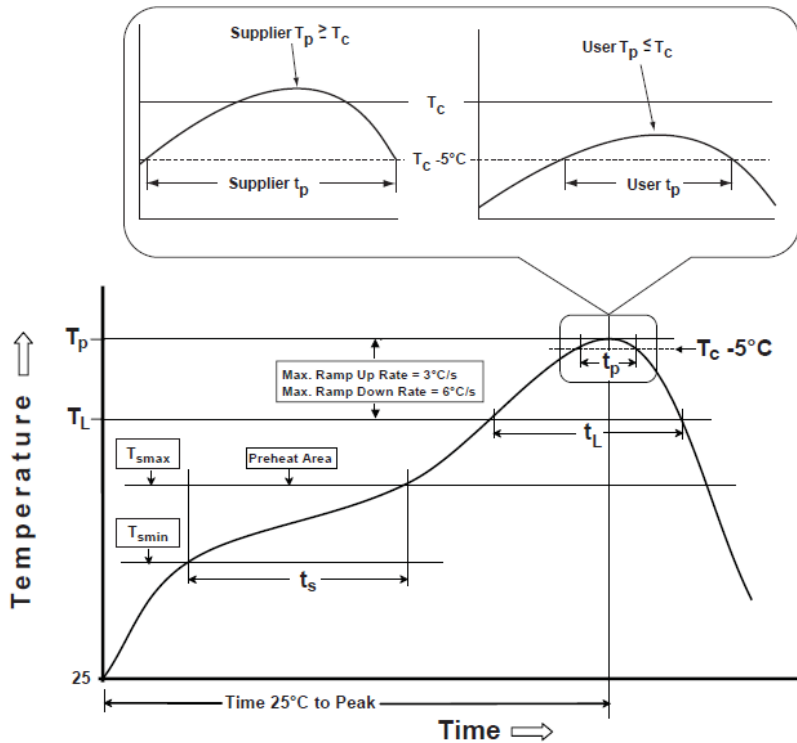

Table 1

SnPb Eutectic Process
Classification Temperatures (T_c)

| Package Thickness | Volume mm ³ <350 | Volume mm ³ ≥350 |
|-------------------|-----------------------------|-----------------------------|
| <2.5 mm | 235 °C | 220 °C |
| ≥2.5 mm | 220 °C | 220 °C |

Table 2

Pb-Free Process
Classification Temperatures (T_c)

| Package Thickness | Volume mm ³ <350 | Volume mm ³ 350-2000 | Volume mm ³ >2000 |
|-------------------|-----------------------------|---------------------------------|------------------------------|
| <1.6 mm | 260 °C | 260 °C | 260 °C |
| 1.6 mm - 2.5 mm | 260 °C | 250 °C | 245 °C |
| >2.5 mm | 250 °C | 245 °C | 245 °C |

| Profile Feature | Sn-Pb Eutectic Assembly | Pb-Free Assembly |
|---|-------------------------|------------------|
| Preheat / soak | | |
| Temperature minimum (T_{smin}) | 100°C | 150°C |
| Temperature maximum (T_{smax}) | 150°C | 200°C |
| Time (T_{smin} to T_{smax}) (t_s) | 60 - 120 sec. | 60 - 120 sec. |
| Average ramp-up rate (T_{smax} to T_p) | 3°C/sec. max | 3°C/sec. max |
| Liquidous temperature (T_L) | 183°C | 217°C |
| Time at liquidous (t_L) | 60 - 150 sec. | 60 - 150 sec. |
| Peak package body temperature (T_p)* | see Table 1 | see Table 2 |
| Time (t_p)** within 5°C of the specified classification temperature (T_c) | 20 sec. | 30 sec. |
| Ramp-down rate (T_p to T_{smax}) | 6°C/sec. max | 6°C/sec. max |
| Time 25°C to peak temperature | 6 min. max | 8 min. max |
| Reflow cycles | 2 max | 2 max |

*Tolerance for peak profile temperature (T_p) is defined as a supplier minimum and a user maximum.

**Tolerance for time at peak profile temperature (t_p) is defined as supplier minimum and a user maximum.

CERAMIC SMD CRYSTAL

ABMM2

Request Samples



Check Inventory



6.0 x 3.5 x 1.2 mm
RoHS/RoHS II Compliant
 MSL Level = N/A



Packing

T: Tape and reel (1,000pcs/reel)

T2: Tape and reel (250pcs/reel)

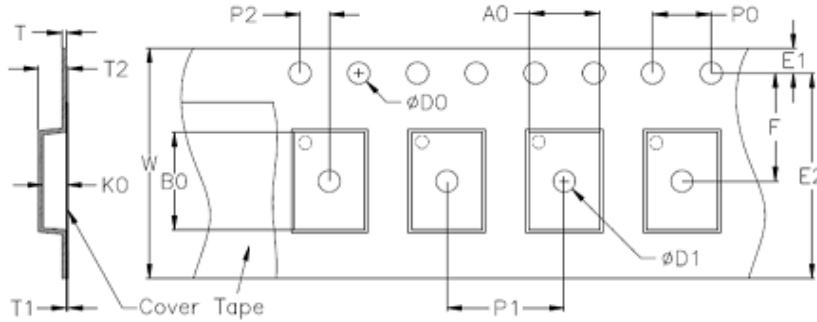

| Tape Size | W max. | D0 | D1 min. | E1 | F | P0 | P1 | P2 |
|-----------|----------|-----|---------|----------|----------|---------|---------|---------|
| 16mm | 16.0±0.3 | 1.5 | 1.5 | 1.75±0.1 | 7.5±0.1 | 4.0±0.1 | 8.0±0.1 | 2.0±0.1 |
| 12mm | 12.0±0.2 | | | | 5.5±0.05 | | | |

| Tape Size | T | T2 max. | B0 | K0 |
|-----------|----------|---------|---------|---------|
| 16mm | 0.3±0.05 | 1.5±0.1 | 6.4±0.1 | 1.5±0.1 |
| 12mm | | 1.8±0.1 | | 1.8±0.1 |

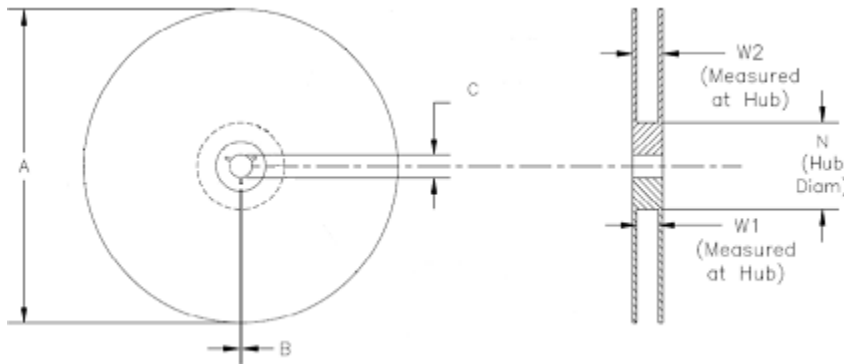

| Tape Size | A max. | B min. | C | N | W1 | W2 max. |
|-----------|--------|---------|----------|----------|----------|----------|
| 16mm | 178±1 | 2.5±0.5 | 13.2±0.5 | 80.0 | 17.5±0.2 | 21.0±2.0 |
| 12mm | | | | 60.2±0.5 | 13.0±0.3 | 16±1.4 |

Dimensions: mm

ATTENTION: Abracon LLC's products are COTS – Commercial-Off-The-Shelf products; suitable for Commercial, Industrial and, where designated, Automotive Applications. Abracon's products are not specifically designed for Military, Aviation, Aerospace, Life-dependent Medical applications or any application requiring high reliability where component failure could result in loss of life and/or property. For applications requiring high reliability and/or presenting an extreme operating environment, written consent and authorization from Abracon LLC is required. Please contact Abracon LLC for more information.



5101 Hidden Creek Ln Spicewood TX 78669
 Phone: 512-371-6159 | Fax: 512-351-8858
 For terms and conditions of sales, please visit:
www.abracon.com

REVISED: 07-31-24

ABRACON IS
 ISO9001-2015
 CERTIFIED

Looking for pricing, stock, or lifecycle information?

Click below to explore more details on WIN SOURCE:

- ⊖ [View ABMM2-8.000MHZ-D1-T on WIN SOURCE](#)
- ⊖ [Abracon LLC Information](#)

Optimize Your Supply Chain with WIN SOURCE Solutions

- ✓ Global Sourcing Solution
- ✓ Obsolete Management
- ✓ Cost Control Management
- ✓ Shortage Management
- ✓ Alternative Solution
- ✓ Excess Inventory Management