

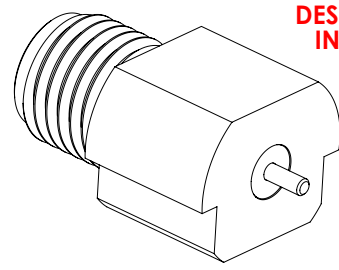

# THE DATASHEET OF SMA-J-P-H-ST-EM3



DO NOT SCALE FROM THIS PRINT



DESIGNED & DIMENSIONED IN MILLIMETERS [INCHES]

**Pb** THIS PRODUCT MANUFACTURED WITH LEAD-FREE PROCESSING

SMA-J-P-X-ST-EM3

GENDER  
-J: JACK

TERMINATION  
-EM3: DROP-IN EDGE MOUNT

ORIENTATION  
-ST: STRAIGHT

TYPE  
-P: PCB

PLATING SPECIFICATION  
-H: HEAVY GOLD/FLASH GOLD (SEE NOTES 7 & 8)  
(SMA-J-P-F-ST-EM3-BDY)  
(SMA-J-P-H-ST-EM3-SKT)  
(SMA-J-P-ST-EM3-INS)

0.05±0.05 [.002±.002] (TO INSULATOR)

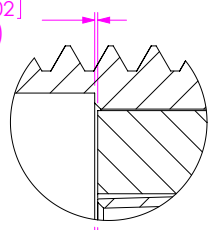

0.05±0.05 [.002±.002] (TO CONTACT)

DETAIL 'B'  
SCALE 8:1

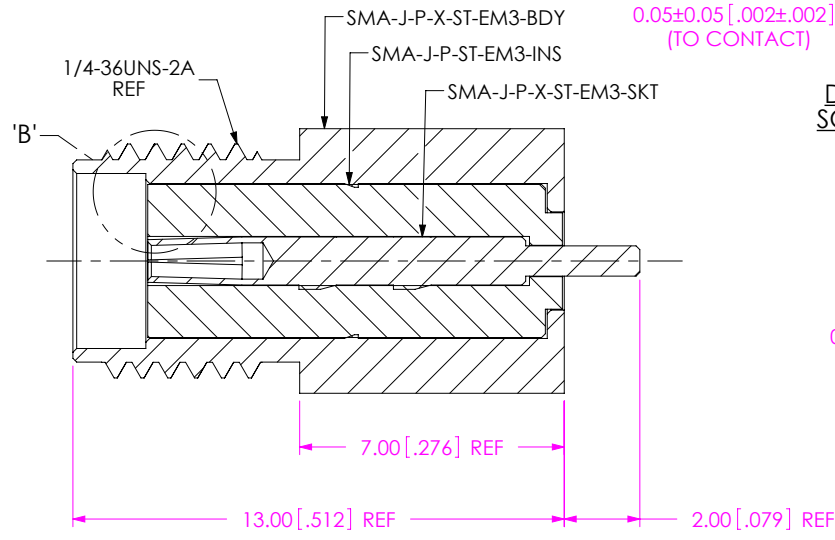

SECTION "A"- "A"

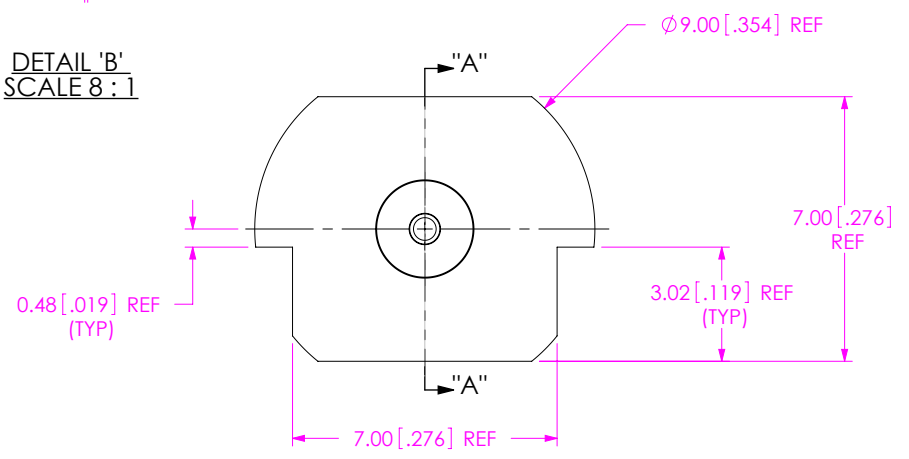

RECOMMENDED PCB LAYOUT

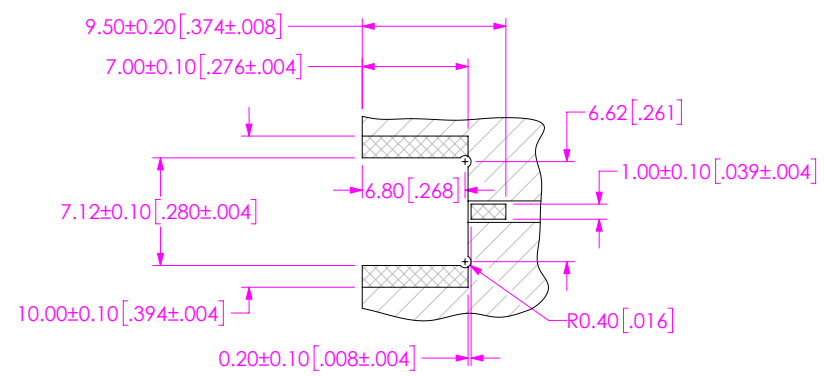

- NOTES:
- ⊕ REPRESENTS A CRITICAL DIMENSION.
  - PUSHOUT FORCE FOR INSULATOR: 44.48 N [10 LBS] MIN.
  - PUSHOUT FORCE FOR CENTER CONTACT: 13.35 N [3 LBS] MIN.
  - PRODUCT TO BE PACKAGED PER PACKAGING STANDARD CO-RF-WI-3040-M.
  - TRAY: TY-SMA001-1; COVER: TY-SMA001-2.
  - RoHS COMPLIANT.
  - COMPONENT PLATING DESIGNATIONS:  
-H: 0.000030" MIN. GOLD OVER 0.000050" MIN. NICKEL.  
-F: 0.000003" MIN. GOLD OVER 0.000050" MIN. NICKEL.
  - ASSEMBLY PLATING DESIGNATIONS:  
-H: (CENTER CONTACT)-H  
(OUTER CONTACT) -F

<p>UNLESS OTHERWISE SPECIFIED, DIMENSIONS ARE IN MILLIMETERS.</p> <p>TOLERANCES ARE:</p> <table border="0"> <tr> <td>DECIMALS</td> <td>ANGLES</td> </tr> <tr> <td>X.X: ±0.3 [.01]</td> <td>5°</td> </tr> <tr> <td>X.XX: ±0.13 [.005]</td> <td></td> </tr> <tr> <td>X.XXX: ±0.051 [.0020]</td> <td></td> </tr> </table>	DECIMALS	ANGLES	X.X: ±0.3 [.01]	5°	X.XX: ±0.13 [.005]		X.XXX: ±0.051 [.0020]		<p>PROPRIETARY NOTE</p> <p>THIS DOCUMENT CONTAINS CONFIDENTIAL AND PROPRIETARY INFORMATION AND ALL DESIGN, MANUFACTURING, REPRODUCTION, USE, PATENT RIGHTS AND SALES RIGHTS ARE EXPRESSLY RESERVED BY SAMTEC, INC. THIS DOCUMENT SHALL NOT BE DISCLOSED, IN WHOLE OR PART, TO ANY UNAUTHORIZED PERSON OR ENTITY NOR REPRODUCED, TRANSFERRED OR INCORPORATED IN ANY OTHER PROJECT IN ANY MANNER WITHOUT THE EXPRESS WRITTEN CONSENT OF SAMTEC, INC.</p>	 <p>520 PARK EAST BLVD, NEW ALBANY, IN 47150 PHONE: 812-944-6733 FAX: 812-948-5047 e-Mail: info@SAMTEC.com code 53322</p>
DECIMALS	ANGLES									
X.X: ±0.3 [.01]	5°									
X.XX: ±0.13 [.005]										
X.XXX: ±0.051 [.0020]										
<p>MATERIAL: DO NOT SCALE DRAWING SHEET SCALE: 5:1</p> <p>BODY: BRASS CONTACT: COPPER ALLOY DIELECTRIC: PTFE</p>	<p>DESCRIPTION: SMA STRAIGHT, EDGE MOUNTING, JACK, 50 OHM DWG. NO. SMA-J-P-X-ST-EM3</p>	<p>BY: ALVIN W 07/25/2010 SHEET 1 OF 2</p>								

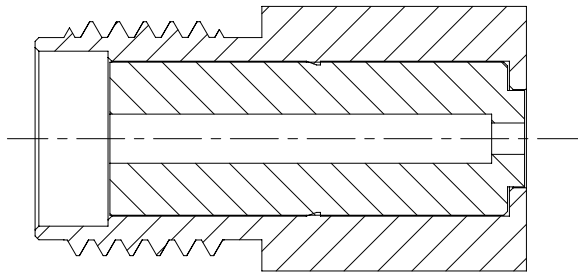

IN-PROCESS 1  
INSERT INSULATOR

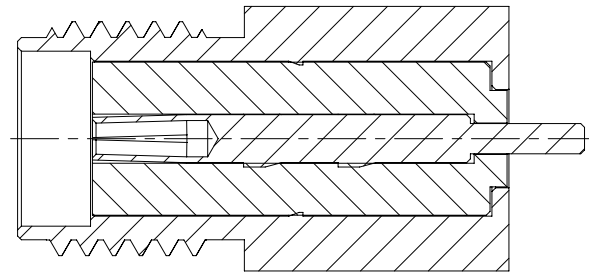

IN-PROCESS 2  
INSERT CONTACT

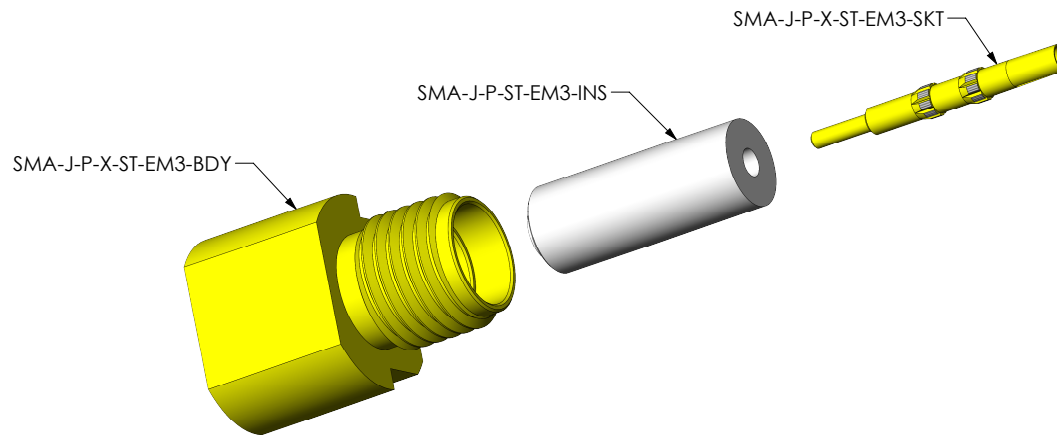

FIG 2  
SMA-J-P-X-ST-EM3 SHONW

**PROPRIETARY NOTE**  
 \* THIS DOCUMENT CONTAINS CONFIDENTIAL AND PROPRIETARY INFORMATION AND ALL DESIGN, MANUFACTURING, REPRODUCTION, USE, PATENT RIGHTS AND SALES RIGHTS ARE EXPRESSLY RESERVED BY SAMTEC, INC. THIS DOCUMENT SHALL NOT BE DISCLOSED, IN WHOLE OR PART, TO ANY UNAUTHORIZED PERSON OR ENTITY NOR REPRODUCED, TRANSFERRED OR INCORPORATED IN ANY OTHER PROJECT IN ANY MANNER WITHOUT THE EXPRESS WRITTEN CONSENT OF SAMTEC, INC. \*

DO NOT SCALE DRAWING

SHEET SCALE: 5:1



520 PARK EAST BLVD, NEW ALBANY, IN 47150  
 PHONE: 812-944-6733 FAX: 812-948-5047  
 e-Mail info@SAMTEC.com code 55322

DESCRIPTION:  
 SMA STRAIGHT, EDGE MOUNTING, JACK, 50 OHM  
 DWG. NO.

**SMA-J-P-X-ST-EM3**

BY: ALVIN W 07/25/2010 SHEET 2 OF 2

## Looking for pricing, stock, or lifecycle information?

Click below to explore more details on WIN SOURCE:

 [View SMA-J-P-H-ST-EM3 on WIN SOURCE](#)

 [Samtec Inc. Information](#)

## Optimize Your Supply Chain with WIN SOURCE Solutions

-  Global Sourcing Solution
-  Obsolete Management
-  Cost Control Management
-  Shortage Management
-  Alternative Solution
-  Excess Inventory Management