



**THE DATASHEET OF
ABP2DRRT001PDAA3XX**



ABP2 SERIES

32350268
Issue F

Board Mount Pressure Sensors

High Accuracy, Compensated/Amplified 6 mbar to 12 bar | 600 Pa to 1.2 MPa | 2 inH₂O to 175 psi
Digital or Analog Output, Liquid Media Capable

DESCRIPTION

The ABP2 Series are piezoresistive silicon pressure sensors offering a digital or analog output for reading pressure over the specified full scale pressure span and temperature range. They are calibrated and temperature compensated for sensor offset, sensitivity, temperature effects and accuracy errors (which include non-linearity, repeatability and hysteresis) using an on-board Application Specific Integrated Circuit (ASIC). Calibrated output values for pressure and temperature are updated at approximately 200 Hz. All products are designed and manufactured according to ISO 9001 standards. The liquid media option includes an additional gel coating to protect the electronics under port P1, which enables use with non-corrosive liquids (e.g. water and saline) and in applications where condensation can occur. The ABP2 Series is available in tube packaging. Pocket tape and reel packaging is available upon request.

APPLICATIONS

- **Medical:** Ventilators/portable ventilators, CPAP, blood analysis, blood pressure monitoring, breast pumps, drug dosing, hospital beds, massage machines, oxygen concentrators, patient monitoring, sleep apnea equipment, urine analyzers and wound therapy
- **Industrial:** HVAC transmitters, life sciences, material handling, pneumatic control and regulation, process gas monitoring and valve positioning/positioners

- **Commercial:** Air beds, coffee makers, washing machines, level measurement, dish washers, vacuum cleaners, hand dryers and rice cookers
- **Transportation:** Air brakes, CNG monitoring, fork lifts and fuel level measurement

FEATURES

- Total Error Band (see Figure 1):
 - As low as ± 1.5 %FSS
- Liquid media option:
 - Compatible with a variety of liquid media
- Long-term stability:
 - As low as ± 0.2 %FSS
- Accuracy:
 - ± 0.25 %FSS BFSL
- Wide pressure range:
 - 6 mbar to 12 bar
 - 600 Pa to 1.2 MPa
 - 2 inH₂O to 175 psi
- High burst pressures
- Wide operating temperature range of -40°C to 110°C [-40°F to 230°F]
- Calibrated over wide temperature range of -40°C to 110°C [-40°F to 230°F]
- 24-bit digital I²C or SPI-compatible output
- Ratiometric analog output
- IoT (Internet of Things) ready interface
- Ultra-low power consumption:
 - As low as 0.01 mW typ. average power
 - 1 Hz measurement frequency
- Meets IPC/JEDEC J-STD-020E Moisture Sensitivity Level 2
- REACH and RoHS compliant
- Temperature output available
- NSF-169, LFGB and BPA compliant materials

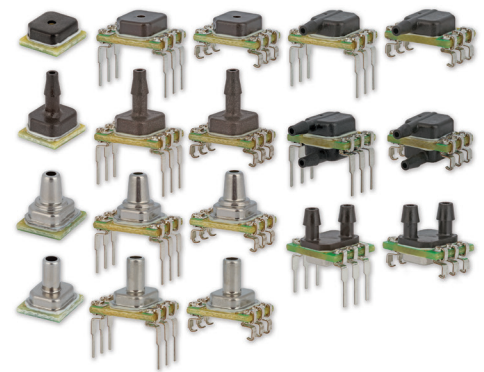

PORTFOLIO

Honeywell offers a variety of board mount pressure sensors for use in medical and industrial applications. To view the entire product portfolio, [click here](#).

Honeywell

BASIC BOARD-MOUNT PRESSURE SENSORS

ABP2 SERIES

VALUE TO CUSTOMERS

- Simplifies design-in:
 - Small size saves room on the PC board (PCB), simplifying design in smaller and lower power devices
- Meets IPC/JEDEC J-STD-020E Moisture Sensitivity Level 2 requirements:
 - Allows avoidance of thermal and mechanical damage during solder reflow attachment and/or repair that lesser rated sensors may incur
 - Allows unlimited storage life, when stored inside sealed moisture barrier bag
 - Allows for lean manufacturing due to stability and usability shortly after reflow
- Cost-effective:
 - Small size helps engineers reduce design and manufacturing costs while maintaining enhanced performance and reliability of the systems they design
- Accurate:
 - Total Error Band (TEB) and wide pressure range enable engineers to optimize system performance by improving resolution and system accuracy
- Flexible:
 - Supply voltage range, variety of pressure units, types and ranges, output options, and wide operating temperature range simplify use in the application
- Versatile:
 - Wet-media compatibility, low power, and temperature output options make the sensor a versatile choice for Internet of Things applications

DIFFERENTIATION

- Application:
 - Specific design ensures suitability for a wide array of customer requirements
- Digital output:
 - Allows the sensor to be directly plugged into the customer's circuitry without requiring major design changes
- Total Error Band (see Figure 1):
 - Provides a more comprehensive measurement of performance over the compensated temperature range, which minimizes testing and calibrating every sensor, thereby potentially reducing manufacturing cost; improves sensor accuracy and offers ease of sensor interchangeability due to minimal part-to-part variation
 - Improves sensor accuracy
 - Offers ease of sensor interchangeability due to minimal part-to-part variation

TABLE OF CONTENTS

4	Total Error Band
5	General Specifications
8	Power Consumption and Standby Mode
8	Digital Output Versions
10	Analog Output Versions
11	Nomenclature and Order Guide
12	Pressure Range Specifications
20	Dimensional Drawings
27	1.0 General Information
27	2.0 Pinout and Functionality
27	3.0 Start-Up Timing
27	4.0 Power Supply Requirement
28	5.0 Reference Circuit Design
28	5.1 Digital Output Versions
28	5.2 Analog Output Versions
28	5.3 Bypass Capacitor Use
29	6.0 I2C Communications
29	6.1 I ² C Bus Configuration
29	6.2 I ² C Data Transfer
29	6.3 I ² C Sensor Address
29	6.4 I ² C Pressure and Temperature Reading
30	6.5 I ² C Status Byte
30	6.6 I ² C Communications
31	6.7 I ² C Timing and Level Parameters
32	6.8 Reference Code (Arduino/Genuino Uno) for I2C Interface
33	7.0 SPI Communications
33	7.1 SPI Definition
33	7.2 SPI Data Transfer
34	7.3 SPI Pressure and Temperature Reading
33	7.4 SPI Status Byte
35	7.5 SPI Communications
36	7.6 SPI Timing and Level Parameters
37	7.7 Reference Code (Arduino/Genuino Uno) for SPI Interface
38	8.0 ABP2 Series Calculations
39	8.1 Digital Output Versions
40	8.2 Analog Output Versions
41	9.0 Recommended Pneumatic Sensor Connections
42	9.1 Tubing
42	9.2 O-ring Manifold Designs

Back cover Additional Information

BASIC BOARD-MOUNT PRESSURE SENSORS

ABP2 SERIES

TOTAL ERROR BAND

Total Error Band (TEB) is a single specification that includes the major sources of sensor error. TEB should not be confused with accuracy, which is actually a component of TEB. TEB is the worst error that the sensor could experience.

Honeywell uses the TEB specification in its datasheet because it is the most comprehensive measurement of a sensor's true accuracy. Honeywell also provides the accuracy specification in order to provide a common comparison with competitors' literature that does not use the TEB specification.

Many competitors do not use TEB—they simply specify the accuracy of their device. Their accuracy specification, however, may exclude certain parameters. On their datasheet, the errors are listed individually. When combined, the total error (or what would be TEB) could be significant.

Figure 1. Total Error Band

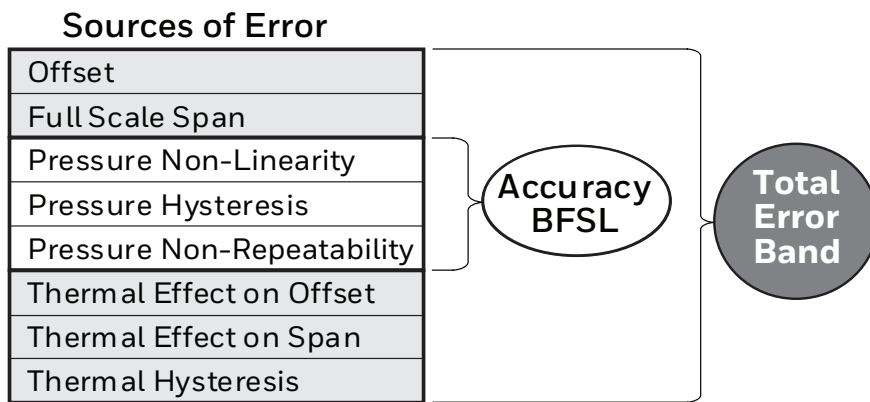

TABLE 1. ABSOLUTE MAXIMUM SPECIFICATIONS¹

Characteristic	Minimum	Maximum	Unit
Supply voltage (V_{supply}):			
digital output	-0.3	3.6	Vdc
analog output	-0.3	6.0	
Voltage on any pin	-0.3	$V_{\text{supply}} + 0.3$	Vdc
Digital clock frequency:			
I ² C	100	400	kHz
SPI	50	800	
ESD susceptibility (human body model)	2	—	kV
Storage temperature range	-40 [-40]	125 [257]	°C [°F]
Soldering time and temperature:			
lead (DIP)	4 s max. at 250°C [482°F]		
peak reflow (SMT, Leadless SMT)	15 s max. at 250°C [482°F]		

¹Absolute maximum ratings are the extreme limits the device will withstand without damage.

BASIC BOARD-MOUNT PRESSURE SENSORS

ABP2 SERIES

TABLE 2. OPERATING SPECIFICATIONS

Characteristic	Analog			Digital			Unit
	Minimum	Typical	Maximum	Minimum	Typical	Maximum	
Supply voltage (V_{supply})¹							
3.3 Vdc	3.0	3.3	3.6	1.8	3.3	3.6	Vdc
5.0 Vdc	4.75	5.0	5.25	—	—	—	
Current consumption:							
I ² C sleep/standby mode	—	—	—	3.0	33.8	211.0	nA
SPI sleep/standby mode	—	—	—	13.0	43.8	221.0	
Power consumption	—	9.5	—	—	3.1	—	mW
Operating temperature range²	-40 [-40]	—	110 [230]	-40 [-40]	—	110 [230]	°C [°F]
Compensated temperature range³	-40 [-40]	—	110 [230]	-40 [-40]	—	110 [230]	°C [°F]
Startup time⁴	—	—	5	—	—	2.5	ms
Clipping limit for analog version:							
Upper	—	—	97.5	—	—	—	V_{supply}
Lower	2.5	—	—	—	—	—	
Update/data rate	—	1000	—	161	204	—	Samples/s
SPI/I²C voltage level:							
Low	—	—	—	—	—	20	% V_{supply}
High	—	—	—	80	—	—	
Pull up on SDA, SCL	—	—	—	1	—	—	kOhm
Total Error Band⁵:							
0°C to 50°C	—	—	±1.5	—	—	±1.5	%FSS ⁶
-20°C to 85°C	—	—	±3.0	—	—	±3.0	%FSS ⁶
-40°C to 110°C	—	—	±4.5	—	—	±4.5	%FSS ⁶
Accuracy⁷	—	—	±0.25	—	—	±0.25	%FSS BFSL
Resolution	0.03	—	—	—	—	—	%FSS bits
Temperature output error⁸	—	—	—	—	±5	—	°C

¹ Sensors are not reverse polarity protected. Incorrect application of supply voltage or ground to the wrong pin may cause electrical failure.

² **Operating temperature range:** The temperature range over which the sensor will produce an output proportional to pressure.

³ **Compensated temperature range:** The temperature range over which the sensor will produce an output proportional to pressure within the specified performance limits (see Total Error Band).

⁴ **Startup Time:** For analog versions: 5 ms to data ready. For digital versions: 2.5 ms for power up to receive the first measurement command. Refer to Section 3.0, Tables 21, 22 and 25 for further details on communication timing.

⁵ **Total Error Band:** The maximum deviation from the ideal transfer function over the entire compensated temperature and pressure range. Includes all errors due to offset, full scale span, pressure non-linearity, pressure hysteresis, repeatability, thermal effect on offset, thermal effect on span and thermal hysteresis.

⁶ **Full Scale Span (FSS):** The algebraic difference between the output signal measured at the maximum (Pmax.) and minimum (Pmin.) limits of the pressure range (see Figure 2).

⁷ **Accuracy:** The maximum deviation in output from a Best Fit Straight Line (BFSL) fitted to the output measured over the pressure range at 25°C [77°F]. Includes all errors due to pressure non-linearity, pressure hysteresis and non-repeatability.

⁸ **Temperature Output Error:** The error in Temperature Output reading relative to a thermal reference standard over a temperature range of -40°C to 125°C.

BASIC BOARD-MOUNT PRESSURE SENSORS

ABP2 SERIES

TABLE 3. ENVIRONMENTAL SPECIFICATIONS

Characteristic	Parameter
Humidity: all external surfaces internal surfaces of liquid media options "T", "V", "G" and "F" internal surfaces of dry gases options "N" and "D"	0 %RH to 95 %RH, non-condensing 0 %RH to 100 %RH, condensing 0 %RH to 95 %RH, non-condensing
Vibration	15 g, 10 Hz to 2 kHz
Shock	75 g, 6 ms duration
Life¹	1 million full scale pressure cycles minimum
Solder reflow	J-STD-020E, MSL 2 (see shelf/floor life)
Shelf life	Unlimited storage life, inside sealed moisture barrier bag
Floor life³	1 year floor life, after removal from sealed moisture bag, <30°C & <60 %RH
Certification (silicone gel coating option, Port 1 only)²	NSF169, BPA Free, LFGB

¹ Life may vary depending on specific application in which the sensor is utilized.

² Sensor materials have been tested and certified for the food safety standards noted.

³ Floor Life, the maximum recommended time period after removal from a moisture barrier bag or dry storage prior to solder reflow. If the maximum recommended floor time is exceeded parts may require to be baked at 85°C for up to 12 hours prior to solder reflow.

TABLE 4. WETTED MATERIALS¹

Component	Pressure Port 1 (P1)		Pressure Port 2 (P2)
	Dry Gas Option	Liquid Media Option	
Ports and covers	High temperature polyamide, 304 SST		High temperature polyamide
Substrate	FR4	—	FR4
Adhesives	Epoxy, silicone	Epoxy, silicone gel, fluorosilicone gel	Epoxy, silicone
Electronic components	Silicon, glass, gold, aluminum		Silicon

¹ Contact Honeywell customer service for detailed material information.

TABLE 5. SENSOR PRESSURE TYPES

Pressure Type	Description
Absolute	Output is proportional to the difference between pressure applied and a built-in vacuum reference.
Differential	Output is proportional to the difference between the applied pressure to each port (Port1 - Port2)
Gage	Output is proportional to the difference between applied pressure and atmospheric (ambient) pressure.

TABLE 6. SENSOR OUTPUT AT SIGNIFICANT PERCENTAGES

Output (%)	Digital Versions		Analog Versions	
	Counts		V _{SUPPLY}	
	Decimal	Hex	3.3 V	5.0 V
0	0	0X000000	0.0	0.0
10	1677722	0X19999A	0.33	0.5
30	5033165	0X4CCCCC	0.99	1.5
50	8388608	0X800000	1.65	2.5
70	11744051	0XB33333	2.31	3.5
90	15099494	0XE66666	2.97	4.5
100	16777215	0XFFFFFF	3.3	5.0

BASIC BOARD-MOUNT PRESSURE SENSORS

ABP2 SERIES

Figure 2. Transfer Function for Digital Output Versions

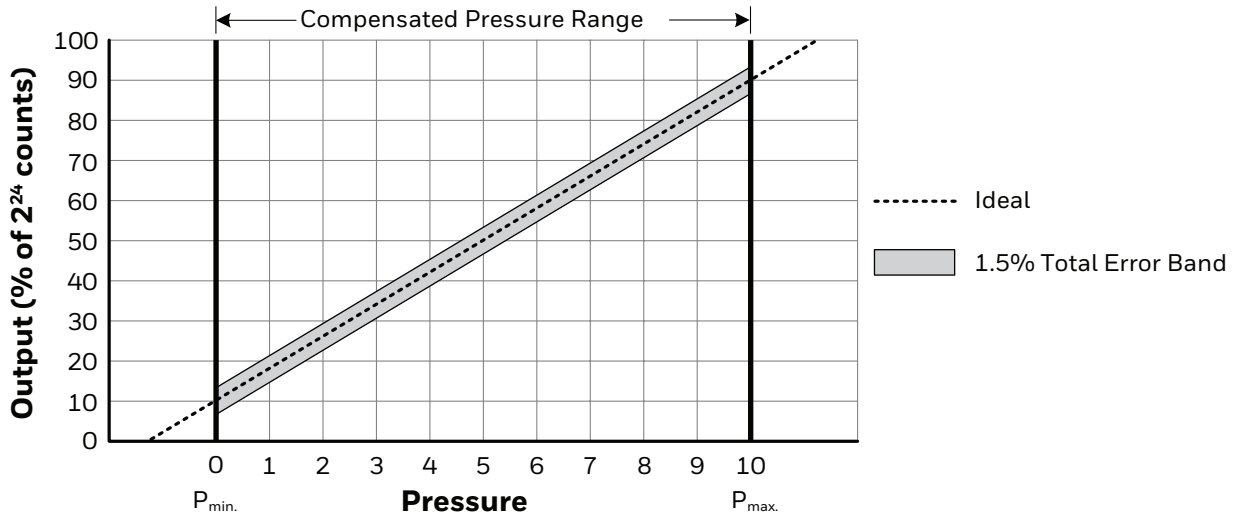

Pressure example 1: Transfer Function A (10% to 90%)

$$\text{Output (\% of } 2^{24} \text{ counts)} = \frac{80\%}{P_{\max.} - P_{\min.}} \times (\text{Pressure}_{\text{applied}} - P_{\min.}) + 10\%$$

Pressure example 2: Transfer Function B (30% to 70%)

$$\text{Output (\% of } 2^{24} \text{ counts)} = \frac{40\%}{P_{\max.} - P_{\min.}} \times (\text{Pressure}_{\text{applied}} - P_{\min.}) + 30\%$$

Figure 3. Transfer Function for Analog Output Versions

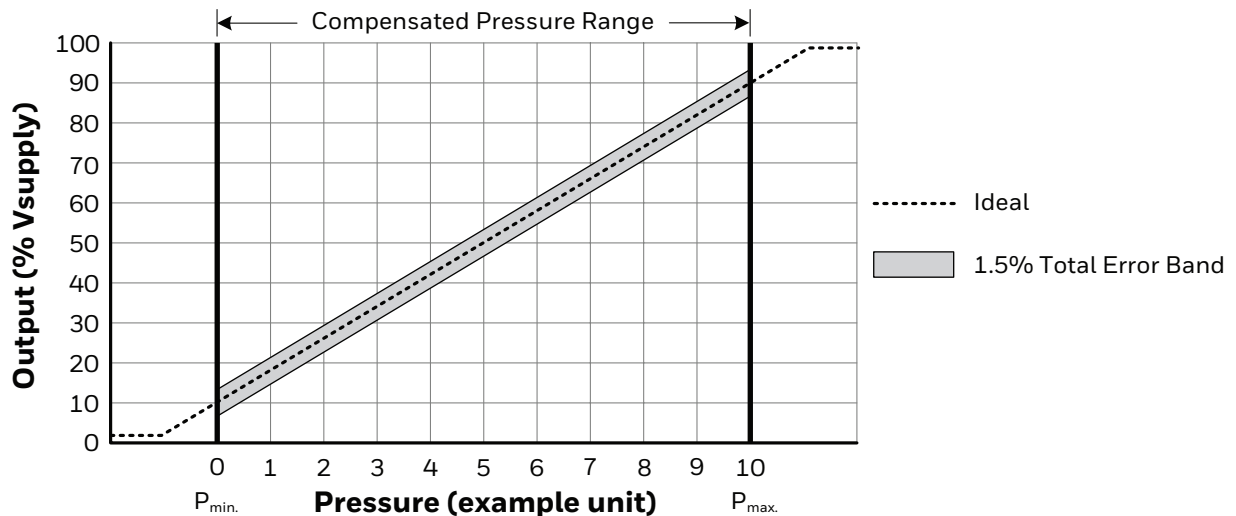

$$\text{Output (V)} = \frac{0.8 \times V_{\text{supply}}}{P_{\max.} - P_{\min.}} \times (\text{Pressure}_{\text{applied}} - P_{\min.}) + 0.10 \times V_{\text{supply}}$$

BASIC BOARD-MOUNT PRESSURE SENSORS

ABP2 SERIES

POWER CONSUMPTION AND STANDBY MODE

DIGITAL OUTPUT VERSIONS

The sensor is normally in Standby Mode and is only turned on in response to a user command, thus minimizing power consumption. Upon receiving the user command, the sensor wakes up from Standby Mode, runs a measurement in Active State, and automatically returns to Standby Mode, awaiting the next command. The resulting sensor power consumption is a function of the sampling rate (samples per second) as shown in Tables 7 and 8 and Figures 4 and 5.

TABLE 7. DIGITAL OUTPUT VERSIONS AVERAGE POWER CONSUMPTION AT 1.8 V_{SUPPLY} (ASSUMES COMMAND AA_{HEX})

Sampling Rate (samples per second)	Average Power (mW)	Active Time (ms)	Active Power (mW)	Idle Time (ms)	Idle Power (mW)
Minimum Average Power					
1	0.0068	3.625	1.884	996.375	0.0000054
2	0.0137	7.25	1.884	992.75	0.0000054
5	0.0341	18.125	1.884	981.875	0.0000054
10	0.0683	36.25	1.884	963.75	0.0000054
20	0.1366	72.5	1.884	927.5	0.0000054
50	0.3414	181.25	1.884	818.75	0.0000054
100	0.6829	362.5	1.884	637.5	0.0000054
160	1.0926	580	1.884	420	0.0000054
Typical Average Power					
1	0.0094	4.157	2.248	995.843	0.00006084
2	0.0187	8.314	2.248	991.686	0.00006084
5	0.0468	20.785	2.248	979.215	0.00006084
10	0.0935	41.57	2.248	958.43	0.00006084
20	0.1870	83.14	2.248	916.86	0.00006084
50	0.4673	207.85	2.248	792.15	0.00006084
100	0.9345	415.7	2.248	584.3	0.00006084
160	1.4592	665.12	2.248	334.88	0.00006084
Maximum Average Power					
1	0.0129	4.839	2.588	995.161	0.0003798
2	0.0254	9.678	2.588	990.322	0.0003798
5	0.0630	24.195	2.588	975.805	0.0003798
10	0.1256	48.39	2.588	951.61	0.0003798
20	0.2508	96.78	2.588	903.22	0.0003798
50	0.6264	241.95	2.588	758.05	0.0003798
100	1.2524	483.9	2.588	516.1	0.0003798
160	2.0036	774.24	2.588	225.76	0.0003798

Figure 4. Digital Output Versions Average Power Consumption vs Sampling Rate at 1.8 V_{SUPPLY}

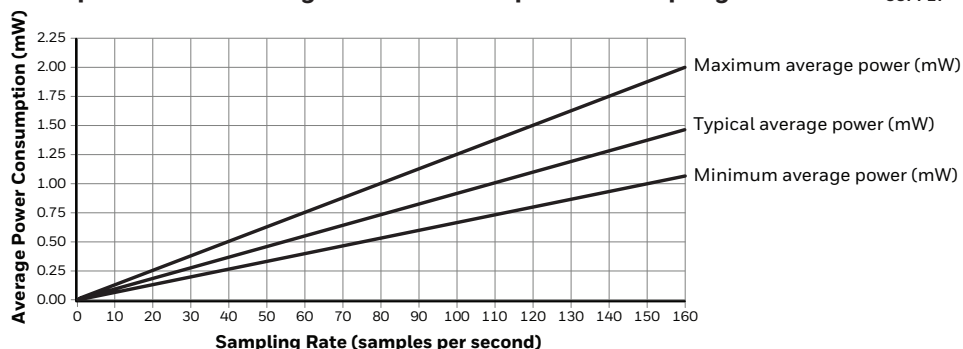

BASIC BOARD-MOUNT PRESSURE SENSORS

ABP2 SERIES

TABLE 8 . DIGITAL OUTPUT VERSIONS AVERAGE POWER CONSUMPTION AT 3.3 V_{SUPPLY} (ASSUMES COMMAND AA_{HEX})

Sampling Rate (samples per second)	Average Power (mW)	Active Time (ms)	Active Power (mW)	Idle Time (ms)	Idle Power (mW)
Minimum Average Power					
1	0.0114	3.625	3.134	996.375	0.0000099
2	0.0227	7.25	3.134	992.75	0.0000099
5	0.0568	18.125	3.134	981.875	0.0000099
10	0.1136	36.25	3.134	963.75	0.0000099
20	0.2272	72.5	3.134	927.5	0.0000099
50	0.5680	181.25	3.134	818.75	0.0000099
100	1.1361	362.5	3.134	637.5	0.0000099
160	1.8177	580	3.134	420	0.0000099
Typical Average Power					
1	0.0156	4.157	3.729	995.843	0.00011154
2	0.0311	8.314	3.729	991.686	0.00011154
5	0.0776	20.785	3.729	979.215	0.00011154
10	0.1551	41.57	3.729	958.43	0.00011154
20	0.3101	83.14	3.729	916.86	0.00011154
50	0.7751	207.85	3.729	792.15	0.00011154
100	1.5501	415.7	3.729	584.3	0.00011154
160	2.4800	665.12	3.729	334.88	0.00011154
Maximum Average Power					
1	0.0214	4.839	4.275	995.161	0.0006963
2	0.0421	9.678	4.275	990.322	0.0006963
5	0.1041	24.195	4.275	975.805	0.0006963
10	0.2075	48.39	4.275	951.61	0.0006963
20	0.4144	96.78	4.275	903.22	0.0006963
50	1.0349	241.95	4.275	758.05	0.0006963
100	2.0692	483.9	4.275	516.1	0.0006963
160	3.3103	774.24	4.275	225.76	0.0006963

Figure 5. Digital Output Versions Average Power Consumption vs Sampling Rate at 3.3 V_{SUPPLY}

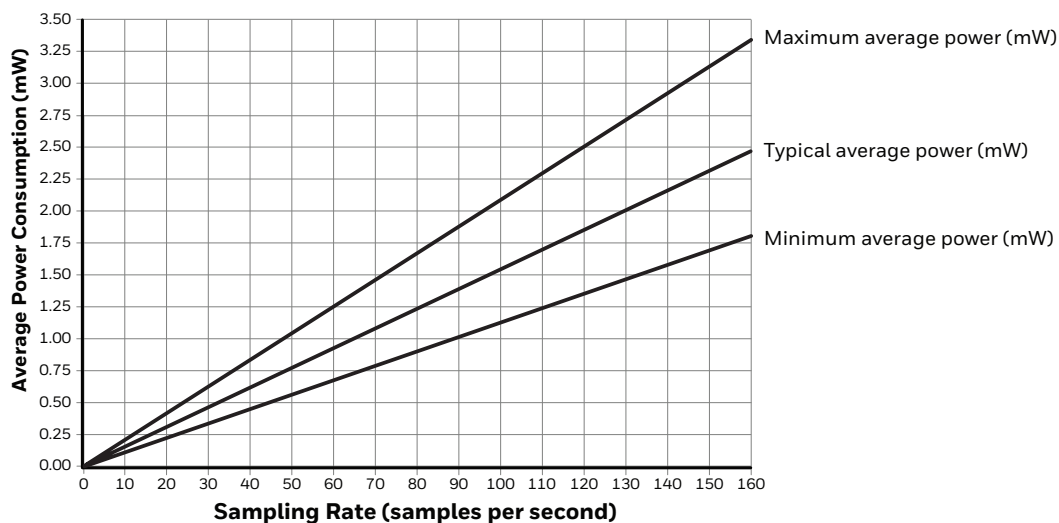

BASIC BOARD-MOUNT PRESSURE SENSORS ABP2 SERIES

ANALOG OUTPUT VERSIONS (SEE TABLE 9 AND FIGURE 6.)

TABLE 9. ANALOG OUTPUT VERSIONS POWER CONSUMPTION				
V _{supply} (V)	Active Power (mW)	Minimum Power (mW)	Average Power (mW)	Maximum Power (mW)
2.8	3.36	3.3	3.4	3.5
3.3	4.62	4.4	4.5	4.7
5	9.5	9.1	9.2	9.4
5.5	11	10.9	11.0	11.1

Figure 6. Analog Output Versions Average Power Consumption

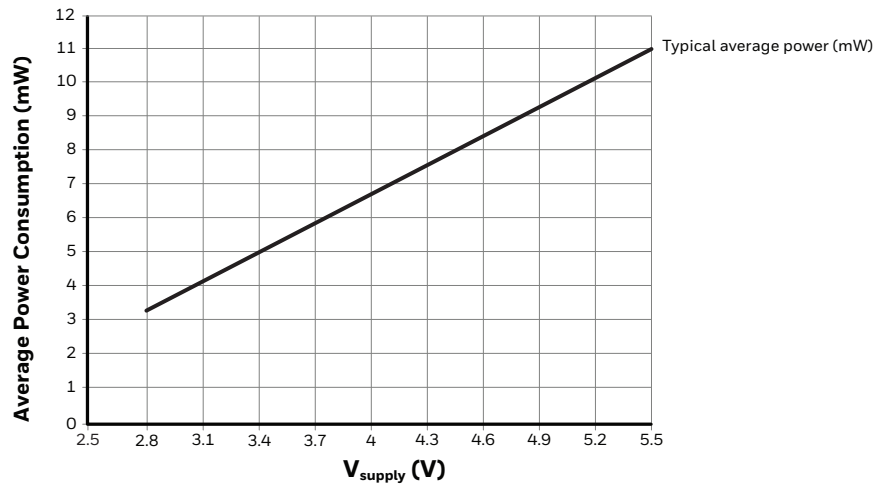

BASIC BOARD-MOUNT PRESSURE SENSORS

ABP2 SERIES

Figure 7. Nomenclature and Order Guide

For example, **ABP2DANT001BA2A3XX** defines an ABP2 Series Amplified Basic Pressure Sensor, DIP package, plastic single axial barbed pressure port, liquid media, food-grade silicone gel, no diagnostics, 1 bar absolute pressure range, digital I²C, address 0x28 output type, 10 % to 90 % of V_{supply} counts (digital) transfer function, 3.3 Vdc supply voltage.

ABP2 D AN T 001BA 2 A 3 XX

Product Series

ABP2 Amplified Basic

Package

D DIP (Dual Inline Pin)

M SMT (Surface Mount Technology)

L Leadless SMT

Pressure Port¹

	DIP	SMT	Leadless SMT
Plastic	NN No port	NN No port	NN No port
	AN Single axial barbed port	AN Single axial barbed port	AN Single axial barbed port
	VN Single axial barbless port	VN Single axial barbless port	VN Single axial barbless port
Metal	SN Single axial straight barbless port	SN Single axial straight barbless port	SN Single axial straight barbless port
	RN Single radial barbed port	RN Single radial barbed port	—
	RR Dual radial barbed ports, same side	RR Dual radial barbed ports, same side	—
Plastic	DA Dual axial barbed ports, same side	DA Dual axial barbed ports, same side	—

Product Option^{2,3,4}

N	Dry gases only, no diagnostics
D	Dry gases only, diagnostics on
T	Liquid media, food-grade silicone gel, no diagnostics
V	Liquid media, food-grade silicone gel, diagnostics on
G	Liquid media, fluorosilicone gel, no diagnostics
F	Liquid media, fluorosilicone gel, diagnostics on

Future

XX

Supply Voltage⁴

3 3.3 Vdc

5 5.0 Vdc

Transfer Function

A 10% to 90% of V_{supply} (analog), 2²⁴ counts (digital)

B 30% to 70% of 2²⁴ counts (digital)

Output Type

A Analog

S SPI

0 I²C, Address 0x08

1 I²C, Address 0x18

2 I²C, Address 0x28

3 I²C, Address 0x38

4 I²C, Address 0x48

5 I²C, Address 0x58

6 I²C, Address 0x68

7 I²C, Address 0x78

Pressure Range

6 mbar to 12 bar Absolute		600 Pa to 1.2 MPa Absolute		2 inH ₂ O to 175 psi Absolute	
001BA	1 bar	100KA	100 kPa	015PA	15 psi
1.6BA	1.6 bar	160KA	160 kPa	030PA	30 psi
2.5BA	2.5 bar	250KA	250 kPa	060PA	60 psi
004BA	4 bar	400KA	400 kPa	100PA	100 psi
006BA	6 bar	600KA	600 kPa	150PA	150 psi
010BA	10 bar	001GA	1.2 MPa	175PA	175 psi
012BA	12 bar				

Differential		Differential		Differential	
006MD	±6 mbar	600LD	±600 Pa	002ND	±2 inH ₂ O
010MD	±10 mbar	001KD	±1 kPa	004ND	±4 inH ₂ O
016MD	±16 mbar	1.6KD	±1.6 kPa	005ND	±5 inH ₂ O
025MD	±25 mbar	2.5KD	±2.5 kPa	010ND	±10 inH ₂ O
040MD	±40 mbar	004KD	±4 kPa	020ND	±20 inH ₂ O
060MD	±60 mbar	006KD	±6 kPa	030ND	±30 inH ₂ O
100MD	±100 mbar	010KD	±10 kPa	001PD	±1 psi
160MD	±160 mbar	016KD	±16 kPa	005PD	±5 psi
250MD	±250 mbar	025KD	±25 kPa	015PD	±15 psi
400MD	±400 mbar	040KD	±40 kPa	030PD	±30 psi
600MD	±600 mbar	060KD	±60 kPa	060PD	±60 psi
0018D	±1 bar	100KD	±100 kPa		
1.68D	±1.6 bar	160KD	±160 kPa		
2.58D	±2.5 bar	250KD	±250 kPa		
0048D	±4 bar	400KD	±400 kPa		

Gage ⁵		Gage ⁵		Gage ⁵	
010MG	10 mbar	001KG	1 kPa	004NG	4 inH ₂ O
016MG	16 mbar	1.6KG	1.6 kPa	005NG	5 inH ₂ O
025MG	25 mbar	2.5KG	2.5 kPa	010NG	10 inH ₂ O
040MG	40 mbar	004KG	4 kPa	020NG	20 inH ₂ O
060MG	60 mbar	006KG	6 kPa	030NG	30 inH ₂ O
100MG	100 mbar	010KG	10 kPa	001PG	1 psi
160MG	160 mbar	016KG	16 kPa	005PG	5 psi
250MG	250 mbar	025KG	25 kPa	015PG	15 psi
400MG	400 mbar	040KG	40 kPa	030PG	30 psi
600MG	600 mbar	060KG	60 kPa	060PG	60 psi
001BG	1 bar	100KG	100 kPa	100PG	100 psi
1.6BG	1.6 bar	160KG	160 kPa	150PG	150 psi
2.5BG	2.5 bar	250KG	250 kPa	175PG	175 psi
004BG	4 bar	400KG	400 kPa		
006BG	6 bar	600KG	600 kPa		
008BG	8 bar	800KG	800 kPa		
010BG	10 bar	001GG	1 MPa		
012BG	12 bar	1.2GG	1.2 MPa		

¹ The "DA" Pressure Port is only available with Product Options "N" and "D". The "DA" Pressure Port is available in standard listings with pressure ranges up to 400 mbar | ±160 mbar. For higher pressure ranges, please contact the technical support team.

² Product Options "N" and "D" are only available with gage pressure ranges 10 mbar to 40 mbar | 1 kPa to 4 kPa | 4 in-H₂O to 20 in-H₂O and differential pressure ranges ±6 mbar to ±25 mbar | ±1 kPa to ±2.5 kPa | ±2 in-H₂O to ±10 in-H₂O.

³ Product Options "T" and "V" are only available with pressure ranges 60 mbar | 6 kPa | 1 psi gage and ±40 mbar | ±4 kPa | 1 psi differential and above.

⁴ 5 Vdc supply voltage and diagnostic options are only available with analog output listings. They are not available with digital output listings.

⁵ 10 mbar, 1 kPa, and 4 in-H₂O pressure ranges are limited to 11-bit resolution for analog output listings.

⁶ Ultra low pressure ranges less than 1 psi are not available as standard listing in leadless package, please contact the technical support team for such requests.

⁷ ABP2 series pressure sensors are piezo-resistive based which are sensitive to change in light intensity. These semiconductor materials when exposed to light, change the output resulting in sensor offset voltage. For applications where direct exposure to light is possible, we recommend Fluorosilicone gel listings which are less susceptible to light transmitting to the sense die.

BASIC BOARD-MOUNT PRESSURE SENSORS

ABP2 SERIES

SELECT ABP2 SERIES SENSORS MOUNTED ON BREAKOUT BOARDS

Breakout boards, with or without the sensor premounted (see Figure 8 and Tables 10, 11, and 12) are designed for use with the Honeywell SEB Sensor Evaluation Kit.

Figure 8. APB2 Series Sensors and Breakout Boards

SN Leadless SMT sensor premounted on breakout board (ABP2LSNT060PGSA3BB)

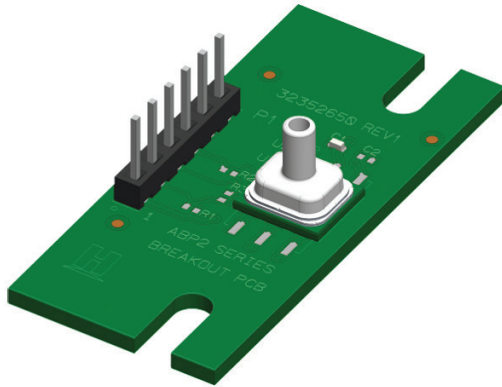

Breakout board (ABP2-BREAKOUT-BRD)

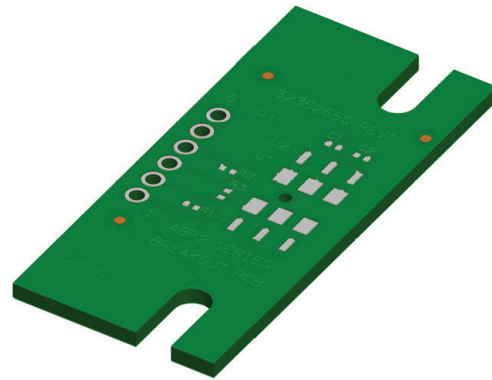

TABLE 10. ORDER GUIDE FOR ABP2 SERIES SENSORS AND BREAKOUT BOARDS

Catalog Listing	Description
ABP2MRRN004ND2B3BB	ABP2 Series sensor with SMT package, plastic dual radial barbed ports, same side pressure port, dry gases only, no diagnostics, ± 4 inH ₂ O differential pressure range, I ² C address 0x28, 30 % to 70 % of 2 ²⁴ counts digital transfer function, 3.3 Vdc supply premounted on breakout board
ABP2MDAN004ND2B3BB	ABP2 Series sensor with SMT package, plastic dual axial barbed ports same side, dry gases only, no diagnostics, ± 4 inH ₂ O differential pressure range, I ² C address 0x28, 30 % to 70 % of 2 ²⁴ counts digital transfer function, 3.3 Vdc supply premounted on breakout board
ABP2MVNT400MG2A3BB	ABP2 Series sensor with leaded SMT package, metal single axial tapered pressure port, liquid media, food-grade silicone gel, no diagnostics, 400 mbar gage pressure range, I ² C address 0x28, 10 % to 90 % of 2 ²⁴ counts digital transfer function, 3.3 Vdc supply premounted on breakout board
ABP2LANT001PG2A3BB	ABP2 Series sensor with leadless SMT package, plastic single axial barbed pressure port, liquid media, food-grade silicone gel, no diagnostics, 1 psi gage pressure range, I ² C address 0x28, 10 % to 90 % of 2 ²⁴ counts digital transfer function, 3.3 Vdc supply premounted on breakout board
ABP2LSNT060PGSA3BB	ABP2 Series sensor with leadless SMT package, metal single axial straight barbless pressure port, liquid media, food-grade silicone gel, no diagnostics, 60 psi gage pressure range, SPI output type, 10 % to 90 % of 2 ²⁴ counts digital transfer function, 3.3 Vdc supply premounted on breakout board
ABP2LANT001BA2A3BB	ABP2 Series sensor with leadless SMT package, plastic single axial barbed pressure port, liquid media, food-grade silicone gel, no diagnostics, 1 bar absolute pressure range, I ² C address 0x28, 10 % to 90 % of 2 ²⁴ counts digital transfer function, 3.3 Vdc supply premounted on breakout board
ABP2-BREAKOUT-BRD	Bare breakout board for use with SMT and leadless SMT packages with AN, SN, VN, NN, RN, or RR pressure ports

BASIC BOARD-MOUNT PRESSURE SENSORS ABP2 SERIES

SELECT ABP2 SERIES SENSORS MOUNTED ON BREAKOUT BOARDS (CONTINUED)

TABLE 11. BREAKOUT BOARD ASSEMBLY DETAILS

SL Number	REF Designator	Description	Manufacturer Part Number	Populate	Description
1	C1	Capacitor, ceramic, 0.1 μ F, 16 V, X7R, 10 % SMD 0402	GCM155R71C104KA55J	Populated	A decoupling capacitor, breakout board shipped with this part assembled
2	C2	Capacitor, ceramic SMD 0402	NA	DNP	Do not populate
3	R1, R2	Resistor SMD 0402 SCL line/R1 and SDA line R2	NA	DNP	Optional pull-up resistors for I ² C output (not populated on the breakout board); recommended pull-up resistor value: 1 kOhm to 10 kOhm
4	R3	Resistor, SMD 0402	NA	DNP	Jumper resistor, do not populate
5	P1	Connector, header, 6 pin, straight, 2,54 mm pitch through hole	826629-6	Populated	6 pin connector
6	U1	ABP2 sensor	ABP2	Populated	Respective ABP2 sensor mounted

TABLE 12. BREAKOUT BOARD PINOUTS

Pin Number	I ² C Output	SPI Output
1	V _{DD}	V _{DD}
2	SCL	SCLK
3	EOC	MISO
4	SDA	MOSI
5	GND	GND
6	NC	SS

BASIC BOARD-MOUNT PRESSURE SENSORS

ABP2 SERIES

TABLE 13. PRESSURE RANGE SPECIFICATIONS: 6 MBAR TO 12 BAR FOR PRODUCT OPTIONS "N", "D", "T" AND "V" ONLY

Pressure Range	Pressure Range		Unit	Overpressure ¹		Burst Pressure ²		Common Mode Pressure ³	Total Error Band ⁴ (%FSS)			Typical Offset Shift with Reflow (%FSS)	Long-term Stability (1000 HR) (%FSS)	Transfer Function for Digital Versions
	P _{Min.}	P _{Max.}		Port 1 (P1)	Port 2 (P2)	Port 1 (P1)	Port 2 (P2)		0°C to 50°C	-20°C to 85°C	-40°C to 110°C			
Absolute														
001BA	0	1	bar	16	—	25	—	—	±1.5	±3.0	±4.5	±1.0	±0.2	A
1.6BA	0	1.6	bar	16	—	25	—	—	±1.5	±3.0	±4.5	±1.0	±0.2	A
2.5BA	0	2.5	bar	16	—	25	—	—	±1.5	±3.0	±4.5	±1.0	±0.2	A
Differential														
006MD	-6	6	mbar	700	700	7000	1000	—	±2.0	±3.5	—	±1.0	±0.3	B
010MD	-10	10	mbar	700	700	7000	1000	—	±2.0	±3.5	—	±1.0	±0.3	B
016MD	-16	16	mbar	700	700	7000	1000	—	±2.0	±3.5	—	±1.0	±0.3	A
025MD	-25	25	mbar	700	700	7000	1000	—	±2.0	±3.5	—	±1.0	±0.3	A
040MD	-40	40	mbar	2000	1000	7000	2000	2000	±1.5	±3.0	±4.5	±1.0	±0.2	A
060MD	-60	60	mbar	2000	1000	7000	2000	2000	±1.5	±3.0	±4.5	±1.0	±0.2	A
100MD	-100	100	mbar	2000	1000	7000	2000	2000	±1.5	±3.0	±4.5	±1.0	±0.2	A
160MD	-160	160	mbar	2000	1000	7000	2000	2000	±1.5	±3.0	±4.5	±1.0	±0.2	A
250MD	-250	250	mbar	16000	—	25000	—	16000	±1.5	±3.0	±4.5	±1.0	±0.6	A
400MD	-400	400	mbar	16000	—	25000	—	16000	±1.5	±3.0	±4.5	±1.0	±0.6	A
600MD	-600	600	mbar	16000	—	25000	—	16000	±1.5	±3.0	±4.5	±1.0	±0.6	A
001BD	-1	1	bar	16	—	25	—	16	±1.5	±3.0	±4.5	±1.0	±0.2	A
1.6BD	-1.6	1.6	bar	16	—	25	—	16	±1.5	±3.0	±4.5	±1.0	±0.2	A
2.5BD	-2.5	2.5	bar	16	—	25	—	16	±1.5	±3.0	±4.5	±1.0	±0.2	A
004BD	-4	4	bar	16	—	25	—	16	±1.5	±3.0	±4.5	±1.0	±0.2	A
Gage														
010MG	0	10	mbar	700	—	7000	—	—	±2.0	±3.5	—	±1.0	±0.3	B
016MG	0	16	mbar	700	—	7000	—	—	±2.0	±3.5	—	±1.0	±0.3	B
025MG	0	25	mbar	700	—	7000	—	—	±2.0	±3.5	—	±1.0	±0.3	A
040MG	0	40	mbar	700	—	7000	—	—	±2.0	±3.5	—	±1.0	±0.3	A
060MG	0	60	mbar	2000	—	7000	—	—	±1.5	±3.0	±4.5	±1.0	±0.2	A
100MG	0	100	mbar	2000	—	7000	—	—	±1.5	±3.0	±4.5	±1.0	±0.2	A
160MG	0	160	mbar	2000	—	7000	—	—	±1.5	±3.0	±4.5	±1.0	±0.2	A
250MG	0	250	mbar	2000	—	7000	—	—	±1.5	±3.0	±4.5	±1.0	±0.2	A
400MG	0	400	mbar	2000	—	7000	—	—	±1.5	±3.0	±4.5	±1.0	±0.2	A
600MG	0	600	mbar	16000	—	25000	—	—	±1.5	±3.0	±4.5	±1.0	±0.6	A
001BG	0	1	bar	16	—	25	—	—	±1.5	±3.0	±4.5	±1.0	±0.5	A
1.6BG	0	1.6	bar	16	—	25	—	—	±1.5	±3.0	±4.5	±1.0	±0.3	A
2.5BG	0	2.5	bar	16	—	25	—	—	±1.5	±3.0	±4.5	±1.0	±0.2	A
004BG	0	4	bar	16	—	25	—	—	±1.5	±3.0	±4.5	±1.0	±0.2	A
006BG	0	6	bar	16	—	25	—	—	±1.5	±3.0	±4.5	±1.0	±0.2	A
008BG	0	8	bar	16	—	25	—	—	±1.5	±3.0	±4.5	±1.0	±0.2	A
010BG	0	10	bar	16	—	25	—	—	±1.5	±3.0	±4.5	±1.0	±0.2	A
012BG	0	12	bar	16	—	25	—	—	±1.5	±3.0	±4.5	±1.0	±0.2	A

¹**Overpressure:** The maximum pressure which may safely be applied to the product for it to remain in specification once pressure is returned to the operating pressure range. Exposure to higher pressures may cause permanent damage to the product. Unless otherwise specified, this applies to all available pressure ports at any temperature within the operating temperature range.

²**Burst Pressure:** The maximum pressure that may be applied to any port of the product without causing escape of pressure media. The product should not be expected to function after exposure to any pressure beyond the burst pressure.

³**Common Mode Pressure:** The maximum pressure that can be applied simultaneously to both ports of a differential pressure sensor without causing changes in specified performance.

⁴**Total Error Band:** The maximum deviation from the ideal transfer function over the entire compensated temperature and pressure range without causing changes in specified performance.

BASIC BOARD-MOUNT PRESSURE SENSORS

ABP2 SERIES

TABLE 14. PRESSURE RANGE SPECIFICATIONS: 250 MBAR TO 12 BAR FOR PRODUCT OPTIONS "G" AND "F" ONLY

Pressure Range	Pressure Range		Unit	Overpressure ¹		Burst Pressure ²		Common Mode Pressure ³	Total Error Band ⁴ (%FSS)			Typical Offset Shift with Reflow (%FSS)	Long-term Stability (1000 HR) (%FSS)	Transfer Function for Digital Versions
	P _{Min.}	P _{Max.}		Port 1 (P1)	Port 2 (P2)	Port 1 (P1)	Port 2 (P2)		0°C to 50°C	-20°C to 85°C	-40°C to 110°C			
Absolute														
001BA	0	1	bar	16	—	25	—	—	±2.0	±3.0	±4.5	±1.0	±0.5	A
1.6BA	0	1.6	bar	16	—	25	—	—	±2.0	±3.0	±4.5	±1.0	±0.5	A
2.5BA	0	2.5	bar	16	—	25	—	—	±2.0	±3.0	±4.5	±1.0	±0.5	A
004BA	0	4	bar	16	—	25	—	—	±2.0	±3.0	±4.5	±1.0	±0.5	A
006BA	0	6	bar	16	—	25	—	—	±2.0	±3.0	±4.5	±1.0	±0.5	A
008BA	0	8	bar	16	—	25	—	—	±2.0	±3.0	±4.5	±1.0	±0.5	A
010BA	0	10	bar	16	—	25	—	—	±2.0	±3.0	±4.5	±1.0	±0.5	A
012BA	0	12	bar	16	—	25	—	—	±2.0	±3.0	±4.5	±1.0	±0.5	A
Differential														
250MD	-250	250	mbar	16000	—	25000	—	16000	±2.0	±3.0	±4.5	±1.0	±0.5	A
400MD	-400	400	mbar	16000	—	25000	—	16000	±2.0	±3.0	±4.5	±1.0	±0.5	A
600MD	-600	600	mbar	16000	—	25000	—	16000	±2.0	±3.0	±4.5	±1.0	±0.5	A
001BD	-1	1	bar	16	—	25	—	16	±2.0	±3.0	±4.5	±1.0	±0.5	A
1.6BD	-1.6	1.6	bar	16	—	25	—	16	±2.0	±3.0	±4.5	±1.0	±0.5	A
2.5BD	-2.5	2.5	bar	16	—	25	—	16	±2.0	±3.0	±4.5	±1.0	±0.5	A
004BD	-4	4	bar	16	—	25	—	16	±2.0	±3.0	±4.5	±1.0	±0.5	A
Gage														
600MG	0	600	mbar	16000	—	25000	—	—	±2.0	±3.0	±4.5	±1.0	±0.5	A
001BG	0	1	bar	16	—	25	—	—	±2.0	±3.0	±4.5	±1.0	±0.5	A
1.5BG	0	1.6	bar	16	—	25	—	—	±2.0	±3.0	±4.5	±1.0	±0.5	A
2.5BG	0	2.5	bar	16	—	25	—	—	±2.0	±3.0	±4.5	±1.0	±0.5	A
004BG	0	4	bar	16	—	25	—	—	±2.0	±3.0	±4.5	±1.0	±0.5	A
006BG	0	6	bar	16	—	25	—	—	±2.0	±3.0	±4.5	±1.0	±0.5	A
008BG	0	8	bar	16	—	25	—	—	±2.0	±3.0	±4.5	±1.0	±0.5	A
010BG	0	10	bar	16	—	25	—	—	±2.0	±3.0	±4.5	±1.0	±0.5	A
012BG	0	12	bar	16	—	25	—	—	±2.0	±3.0	±4.5	±1.0	±0.5	A

¹ **Overpressure:** The maximum pressure which may safely be applied to the product for it to remain in specification once pressure is returned to the operating pressure range. Exposure to higher pressures may cause permanent damage to the product. Unless otherwise specified, this applies to all available pressure ports at any temperature within the operating temperature range.

² **Burst Pressure:** The maximum pressure that may be applied to any port of the product without causing escape of pressure media. The product should not be expected to function after exposure to any pressure beyond the burst pressure.

³ **Common Mode Pressure:** The maximum pressure that can be applied simultaneously to both ports of a differential pressure sensor without causing changes in specified performance.

⁴ **Total Error Band:** The maximum deviation from the ideal transfer function over the entire compensated temperature and pressure range without causing changes in specified performance.

BASIC BOARD-MOUNT PRESSURE SENSORS

ABP2 SERIES

TABLE 15. PRESSURE RANGE SPECIFICATIONS: 600 PA TO 1.2 MPA FOR PRODUCT OPTIONS "N", "D", "T" AND "V" ONLY

Pressure Range	Pressure Range		Unit	Overpressure ¹		Burst Pressure ²		Common Mode Pressure ³	Total Error Band ⁴ (%FSS)			Typical Offset Shift with Reflow (%FSS)	Long-term Stability (1000 HR) (%FSS)	Transfer Function for Digital Versions
	P _{Min.}	P _{Max.}		Port 1 (P1)	Port 2 (P2)	Port 1 (P1)	Port 2 (P2)		0°C to 50°C	-20°C to 85°C	-40°C to 110°C			
Absolute														
100KA	0	100	kPa	1600	—	2500	—	—	±1.5	±3.0	±4.5	±1.0	±0.2	A
160KA	0	160	kPa	1600	—	2500	—	—	±1.5	±3.0	±4.5	±1.0	±0.2	A
250KA	0	250	kPa	1600	—	2500	—	—	±1.5	±3.0	±4.5	±1.0	±0.2	A
Differential														
600LD	-600	600	Pa	70000	70000	70000	100000	—	±2.0	±3.5	—	±1.0	±0.3	B
001KD	-1	1	kPa	70	70	700	100	—	±2.0	±3.5	—	±1.0	±0.3	B
1.6KD	-1.6	1.6	kPa	70	70	700	100	—	±2.0	±3.5	—	±1.0	±0.3	A
2.5KD	-2.5	2.5	kPa	70	70	700	100	—	±2.0	±3.5	—	±1.0	±0.3	A
004KD	-4	4	kPa	200	100	700	200	200	±1.5	±3.0	±4.5	±1.0	±0.2	A
006KD	-6	6	kPa	200	100	700	200	200	±1.5	±3.0	±4.5	±1.0	±0.2	A
010KD	-10	10	kPa	200	100	700	200	200	±1.5	±3.0	±4.5	±1.0	±0.2	A
016KD	-16	16	kPa	200	100	700	200	200	±1.5	±3.0	±4.5	±1.0	±0.2	A
025KD	-25	25	kPa	1600	—	2500	—	16000	±1.5	±3.0	±4.5	±1.0	±0.6	A
040KD	-40	40	kPa	1600	—	2500	—	16000	±1.5	±3.0	±4.5	±1.0	±0.6	A
060KD	-60	60	kPa	1600	—	2500	—	16000	±1.5	±3.0	±4.5	±1.0	±0.6	A
100KD	-100	100	kPa	1600	—	2500	—	16000	±1.5	±3.0	±4.5	±1.0	±0.2	A
160KD	-160	160	kPa	1600	—	2500	—	16000	±1.5	±3.0	±4.5	±1.0	±0.2	A
250KD	-250	250	kPa	1600	—	2500	—	16000	±1.5	±3.0	±4.5	±1.0	±0.2	A
400KD	-400	400	kPa	1600	—	2500	—	16000	±1.5	±3.0	±4.5	±1.0	±0.2	A
Gage														
001KG	0	1	kPa	70	—	700	—	—	±2.0	±3.5	—	±1.0	±0.3	B
1.6KG	0	1.6	kPa	70	—	700	—	—	±2.0	±3.5	—	±1.0	±0.3	B
2.5KG	0	2.5	kPa	70	—	700	—	—	±2.0	±3.5	—	±1.0	±0.3	A
004KG	0	4	kPa	70	—	700	—	—	±2.0	±3.5	—	±1.0	±0.3	A
006KG	0	6	kPa	200	—	700	—	—	±1.5	±3.0	±4.5	±1.0	±0.2	A
010KG	0	10	kPa	200	—	700	—	—	±1.5	±3.0	±4.5	±1.0	±0.2	A
016KG	0	16	kPa	200	—	700	—	—	±1.5	±3.0	±4.5	±1.0	±0.2	A
025KG	0	25	kPa	200	—	700	—	—	±1.5	±3.0	±4.5	±1.0	±0.2	A
040KG	0	40	kPa	200	—	700	—	—	±1.5	±3.0	±4.5	±1.0	±0.2	A
060KG	0	60	kPa	1600	—	2500	—	—	±1.5	±3.0	±4.5	±1.0	±0.6	A
100KG	0	100	kPa	1600	—	2500	—	—	±1.5	±3.0	±4.5	±1.0	±0.5	A
160KG	0	160	kPa	1600	—	2500	—	—	±1.5	±3.0	±4.5	±1.0	±0.2	A
250KG	0	250	kPa	1600	—	2500	—	—	±1.5	±3.0	±4.5	±1.0	±0.2	A
400KG	0	400	kPa	1600	—	2500	—	—	±1.5	±3.0	±4.5	±1.0	±0.2	A
600KG	0	600	kPa	1600	—	2500	—	—	±1.5	±3.0	±4.5	±1.0	±0.2	A
800KG	0	800	kPa	1600	—	2500	—	—	±1.5	±3.0	±4.5	±1.0	±0.2	A
001GG	0	1	MPa	1.6	—	2.5	—	—	±1.5	±3.0	±4.5	±1.0	±0.2	A
1.2GG	0	1.2	MPa	1.6	—	2.5	—	—	±1.5	±3.0	±4.5	±1.0	±0.2	A

¹ **Overpressure:** The maximum pressure which may safely be applied to the product for it to remain in specification once pressure is returned to the operating pressure range. Exposure to higher pressures may cause permanent damage to the product. Unless otherwise specified, this applies to all available pressure ports at any temperature within the operating temperature range.

² **Burst Pressure:** The maximum pressure that may be applied to any port of the product without causing escape of pressure media. The product should not be expected to function after exposure to any pressure beyond the burst pressure.

³ **Common Mode Pressure:** The maximum pressure that can be applied simultaneously to both ports of a differential pressure sensor without causing changes in specified performance.

⁴ **Total Error Band:** The maximum deviation from the ideal transfer function over the entire compensated temperature and pressure range without causing changes in specified performance.

BASIC BOARD-MOUNT PRESSURE SENSORS

ABP2 SERIES

TABLE 16. PRESSURE RANGE SPECIFICATIONS: 25 KPA TO 1.2 MPA FOR PRODUCT OPTIONS "G" AND "F" ONLY

Pressure Range	Pressure Range		Unit	Overpressure ¹		Burst Pressure ²		Common Mode Pressure ³	Total Error Band ⁴ (%FSS)			Typical Offset Shift with Reflow (%FSS)	Long-term Stability (1000 HR) (%FSS)	Transfer Function for Digital Versions
	P _{Min.}	P _{Max.}		Port 1 (P1)	Port 2 (P2)	Port 1 (P1)	Port 2 (P2)		0°C to 50°C	-20°C to 85°C	-40°C to 110°C			
Absolute														
100KA	0	100	kPa	1600	—	2500	—	—	±2.0	±3.0	±4.5	±1.0	±0.5	A
160KA	0	160	kPa	1600	—	2500	—	—	±2.0	±3.0	±4.5	±1.0	±0.5	A
250KA	0	250	kPa	1600	—	2500	—	—	±2.0	±3.0	±4.5	±1.0	±0.5	A
400KG	0	400	kPa	1600	—	2500	—	—	±2.0	±3.0	±4.5	±1.0	±0.5	A
600KG	0	600	kPa	1600	—	2500	—	—	±2.0	±3.0	±4.5	±1.0	±0.5	A
800KG	0	800	kPa	1600	—	2500	—	—	±2.0	±3.0	±4.5	±1.0	±0.5	A
001GG	0	1	MPa	1.6	—	2.5	—	—	±2.0	±3.0	±4.5	±1.0	±0.5	A
1.2GG	0	1.2	MPa	1.6	—	2.5	—	—	±2.0	±3.0	±4.5	±1.0	±0.5	A
Differential														
025KD	-25	25	kPa	1600	—	2500	—	1600	±2.0	±3.0	±4.5	±1.0	±0.5	A
040KD	-40	40	kPa	1600	—	2500	—	1600	±2.0	±3.0	±4.5	±1.0	±0.5	A
060KD	-60	60	kPa	1600	—	2500	—	1600	±2.0	±3.0	±4.5	±1.0	±0.5	A
100KD	-100	100	kPa	1600	—	2500	—	1600	±2.0	±3.0	±4.5	±1.0	±0.5	A
160KD	-160	160	kPa	1600	—	2500	—	1600	±2.0	±3.0	±4.5	±1.0	±0.5	A
250KD	-250	250	kPa	1600	—	2500	—	1600	±2.0	±3.0	±4.5	±1.0	±0.5	A
400KD	-400	400	kPa	1600	—	2500	—	1600	±2.0	±3.0	±4.5	±1.0	±0.5	A
Gage														
060KG	0	60	kPa	1600	—	2500	—	—	±2.0	±3.0	±4.5	±1.0	±0.5	A
100KG	0	100	kPa	1600	—	2500	—	—	±2.0	±3.0	±4.5	±1.0	±0.5	A
160KG	0	160	kPa	1600	—	2500	—	—	±2.0	±3.0	±4.5	±1.0	±0.5	A
250KG	0	250	kPa	1600	—	2500	—	—	±2.0	±3.0	±4.5	±1.0	±0.5	A
400KG	0	400	kPa	1600	—	2500	—	—	±2.0	±3.0	±4.5	±1.0	±0.5	A
600KG	0	600	kPa	1600	—	2500	—	—	±2.0	±3.0	±4.5	±1.0	±0.5	A
800KG	0	800	kPa	1600	—	2500	—	—	±2.0	±3.0	±4.5	±1.0	±0.5	A
001GG	0	1	MPa	1.6	—	2.5	—	—	±2.0	±3.0	±4.5	±1.0	±0.5	A
1.2GG	0	1.2	MPa	1.6	—	2.5	—	—	±2.0	±3.0	±4.5	±1.0	±0.5	A

¹ **Overpressure:** The maximum pressure which may safely be applied to the product for it to remain in specification once pressure is returned to the operating pressure range. Exposure to higher pressures may cause permanent damage to the product. Unless otherwise specified, this applies to all available pressure ports at any temperature within the operating temperature range.

² **Burst Pressure:** The maximum pressure that may be applied to any port of the product without causing escape of pressure media. The product should not be expected to function after exposure to any pressure beyond the burst pressure.

³ **Common Mode Pressure:** The maximum pressure that can be applied simultaneously to both ports of a differential pressure sensor without causing changes in specified performance.

⁴ **Total Error Band:** The maximum deviation from the ideal transfer function over the entire compensated temperature and pressure range without causing changes in specified performance.

BASIC BOARD-MOUNT PRESSURE SENSORS

ABP2 SERIES

**TABLE 17. PRESSURE RANGE SPECIFICATIONS: 1PSI TO 175 PSI FOR PRODUCT OPTIONS "N","D","T" AND "V" ONLY
PRESSURE RANGE SPECIFICATIONS: 2 INH₂O TO 1 PSI FOR PRODUCT OPTIONS "N" AND "D" ONLY**

Pressure Range	Pressure Range		Unit	Overpressure ¹		Burst Pressure ²		Common Mode Pressure ³	Total Error Band ⁴ (%FSS)			Typical Offset Shift with Reflow (%FSS)	Long-term Stability (1000 HR) (%FSS)	Transfer Function for Digital Versions
	P _{Min.}	P _{Max.}		Port 1 (P1)	Port 2 (P2)	Port 1 (P1)	Port 2 (P2)		0°C to 50°C	-20°C to 85°C	-40°C to 110°C			
Absolute														
015PA	0	15	psi	240	—	375	—	—	±1.5	±3.0	±4.5	±1.0	±0.2	A
030PA	0	30	psi	240	—	375	—	—	±1.5	±3.0	±4.5	±1.0	±0.2	A
Differential														
002ND	-2	2	inH ₂ O	270	270	2800	415	—	±2.0	±3.5	—	±1.0	±0.3	B
004ND	-4	4	inH ₂ O	270	270	2800	415	—	±2.0	±3.5	—	±1.0	±0.3	B
005ND	-5	5	inH ₂ O	270	270	2800	415	—	±2.0	±3.5	—	±1.0	±0.3	A
010ND	-10	10	inH ₂ O	270	270	2800	415	—	±2.0	±3.5	—	±1.0	±0.3	A
020ND	-20	20	inH ₂ O	830	415	2800	830	830	±1.5	±3.0	±4.5	±1.0	±0.2	A
030ND	-30	30	inH ₂ O	830	415	2800	830	830	±1.5	±3.0	±4.5	±1.0	±0.2	A
001PD	-1	1	psi	30	15	100	30	30	±1.5	±3.0	±4.5	±1.0	±0.2	A
005PD	-5	5	psi	240	—	375	—	240	±1.5	±3.0	±4.5	±1.0	±0.6	A
015PD	-15	15	psi	240	—	375	—	240	±1.5	±3.0	±4.5	±1.0	±0.2	A
030PD	-30	30	psi	240	—	375	—	240	+/-1.5	±3.0	±4.5	±1.0	±0.2	A
060PD	-60	60	psi	240	—	375	—	240	+/-1.5	±3.0	±4.5	±1.0	±0.2	A
Gage														
004NG	0	4	inH ₂ O	270	—	2800	—	—	±2.0	±3.5	—	±1.0	±0.3	B
005NG	0	5	inH ₂ O	270	—	2800	—	—	±2.0	±3.5	—	±1.0	±0.3	B
010NG	0	10	inH ₂ O	270	—	2800	—	—	±2.0	±3.5	—	±1.0	±0.3	A
020NG	0	20	inH ₂ O	270	—	2800	—	—	±2.0	±3.5	—	±1.0	±0.3	A
030NG	0	30	inH ₂ O	830	—	2800	—	—	±1.5	±3.0	±4.5	±1.0	±0.2	A
001PG	0	1	psi	30	—	100	—	—	±1.5	±3.0	±4.5	±1.0	±0.2	A
005PG	0	5	psi	30	—	100	—	—	±1.5	±3.0	±4.5	±1.0	±0.2	A
015PG	0	15	psi	240	—	375	—	—	±1.5	±3.0	±4.5	±1.0	±0.5	A
030PG	0	30	psi	240	—	375	—	—	±1.5	±3.0	±4.5	±1.0	±0.2	A
060PG	0	60	psi	240	—	375	—	—	±1.5	±3.0	±4.5	±1.0	±0.2	A
100PG	0	100	psi	240	—	375	—	—	±1.5	±3.0	±4.5	±1.0	±0.2	A
150PG	0	150	psi	240	—	375	—	—	±1.5	±3.0	±4.5	±1.0	±0.2	A
175PG	0	175	psi	240	—	375	—	—	±1.5	±3.0	±4.5	±1.0	±0.2	A

¹ **Overpressure:** The maximum pressure which may safely be applied to the product for it to remain in specification once pressure is returned to the operating pressure range. Exposure to higher pressures may cause permanent damage to the product. Unless otherwise specified, this applies to all available pressure ports at any temperature within the operating temperature range.

² **Burst Pressure:** The maximum pressure that may be applied to any port of the product without causing escape of pressure media. The product should not be expected to function after exposure to any pressure beyond the burst pressure.

³ **Common Mode Pressure:** The maximum pressure that can be applied simultaneously to both ports of a differential pressure sensor without causing changes in specified performance.

⁴ **Total Error Band:** The maximum deviation from the ideal transfer function over the entire compensated temperature and pressure range without causing changes in specified performance.

BASIC BOARD-MOUNT PRESSURE SENSORS

ABP2 SERIES

TABLE 18. PRESSURE RANGE SPECIFICATIONS: 5 PSI TO 175 PSI FOR PRODUCT OPTIONS "G" AND "F" ONLY

Pressure Range	Pressure Range		Unit	Overpressure ¹		Burst Pressure ²		Common Mode Pressure ³	Total Error Band ⁴ (%FSS)			Typical Offset Shift with Reflow (%FSS)	Long-term Stability (1000 HR) (%FSS)	Transfer Function for Digital Versions
	P _{Min.}	P _{Max.}		Port 1 (P1)	Port 2 (P2)	Port 1 (P1)	Port 2 (P2)		0°C to 50°C	-20°C to 85°C	-40°C to 110°C			
Absolute														
015PA	0	15	psi	240	—	375	—	—	±2.0	±3.0	±4.5	±1.0	±0.5	A
030PA	0	30	psi	240	—	375	—	—	±2.0	±3.0	±4.5	±1.0	±0.5	A
060PA	0	60	psi	240	—	375	—	—	±2.0	±3.0	±4.5	±1.0	±0.5	A
100PA	0	100	psi	240	—	375	—	—	±2.0	±3.0	±4.5	±1.0	±0.5	A
150PA	0	150	psi	240	—	375	—	—	±2.0	±3.0	±4.5	±1.0	±0.5	A
175PA	0	175	psi	240	—	375	—	—	±2.0	±3.0	±4.5	±1.0	±0.5	A
Differential														
005PD	-5	5	psi	240	—	375	—	240	±2.0	±3.0	±4.5	±1.0	±0.5	A
015PD	-15	15	psi	240	—	375	—	240	±2.0	±3.0	±4.5	±1.0	±0.5	A
030PD	-30	30	psi	240	—	375	—	240	±2.0	±3.0	±4.5	±1.0	±0.5	A
060PD	-60	60	psi	240	—	375	—	240	±2.0	±3.0	±4.5	±1.0	±0.5	A
Gage														
015PG	0	15	psi	240	—	375	—	—	±2.0	±3.0	±4.5	±1.0	±0.5	A
030PG	0	30	psi	240	—	375	—	—	±2.0	±3.0	±4.5	±1.0	±0.5	A
060PG	0	60	psi	240	—	375	—	—	±2.0	±3.0	±4.5	±1.0	±0.5	A
100PG	0	100	psi	240	—	375	—	—	±2.0	±3.0	±4.5	±1.0	±0.5	A
150PG	0	150	psi	240	—	375	—	—	±2.0	±3.0	±4.5	±1.0	±0.5	A
175PG	0	175	psi	240	—	375	—	—	±2.0	±3.0	±4.5	±1.0	±0.5	A

¹ **Overpressure:** The maximum pressure which may safely be applied to the product for it to remain in specification once pressure is returned to the operating pressure range. Exposure to higher pressures may cause permanent damage to the product. Unless otherwise specified, this applies to all available pressure ports at any temperature within the operating temperature range.

² **Burst Pressure:** The maximum pressure that may be applied to any port of the product without causing escape of pressure media. The product should not be expected to function after exposure to any pressure beyond the burst pressure.

³ **Common Mode Pressure:** The maximum pressure that can be applied simultaneously to both ports of a differential pressure sensor without causing changes in specified performance.

⁴ **Total Error Band:** The maximum deviation from the ideal transfer function over the entire compensated temperature and pressure range without causing changes in specified performance.

BASIC BOARD-MOUNT PRESSURE SENSORS

ABP2 SERIES

DIMENSIONAL DRAWINGS

Figure 9. DIP Package Dimensional Drawings (For reference only: mm [in.])

DIP NN: Plastic no port

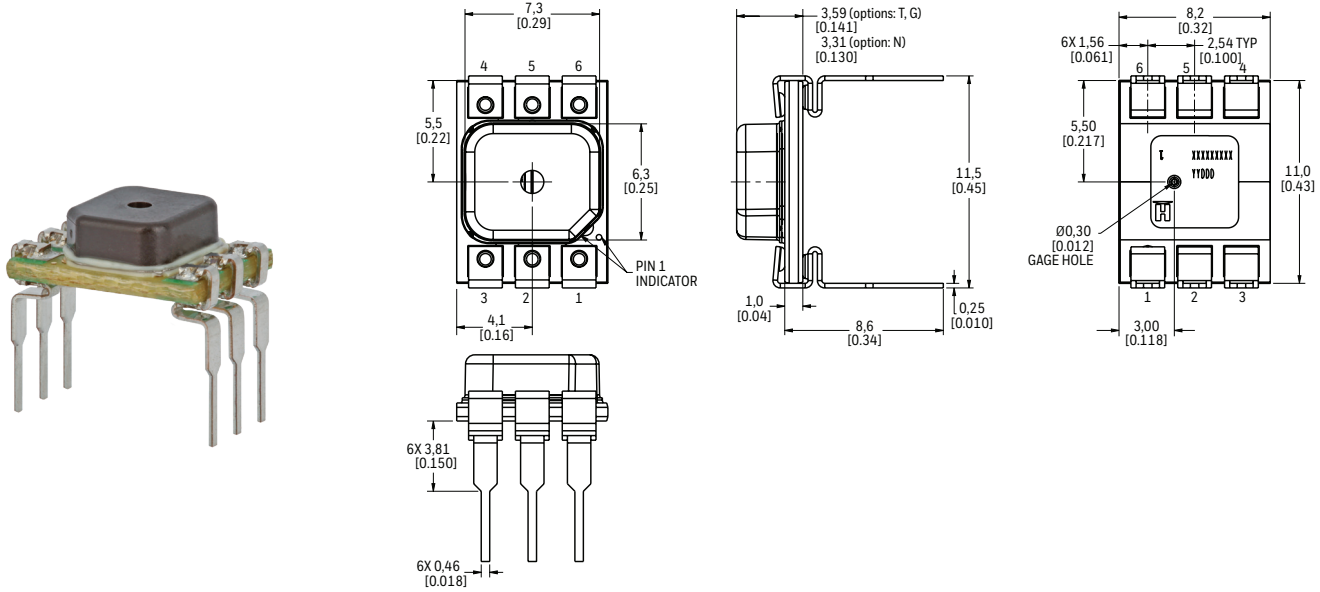

DIP AN: Plastic single axial barbed port

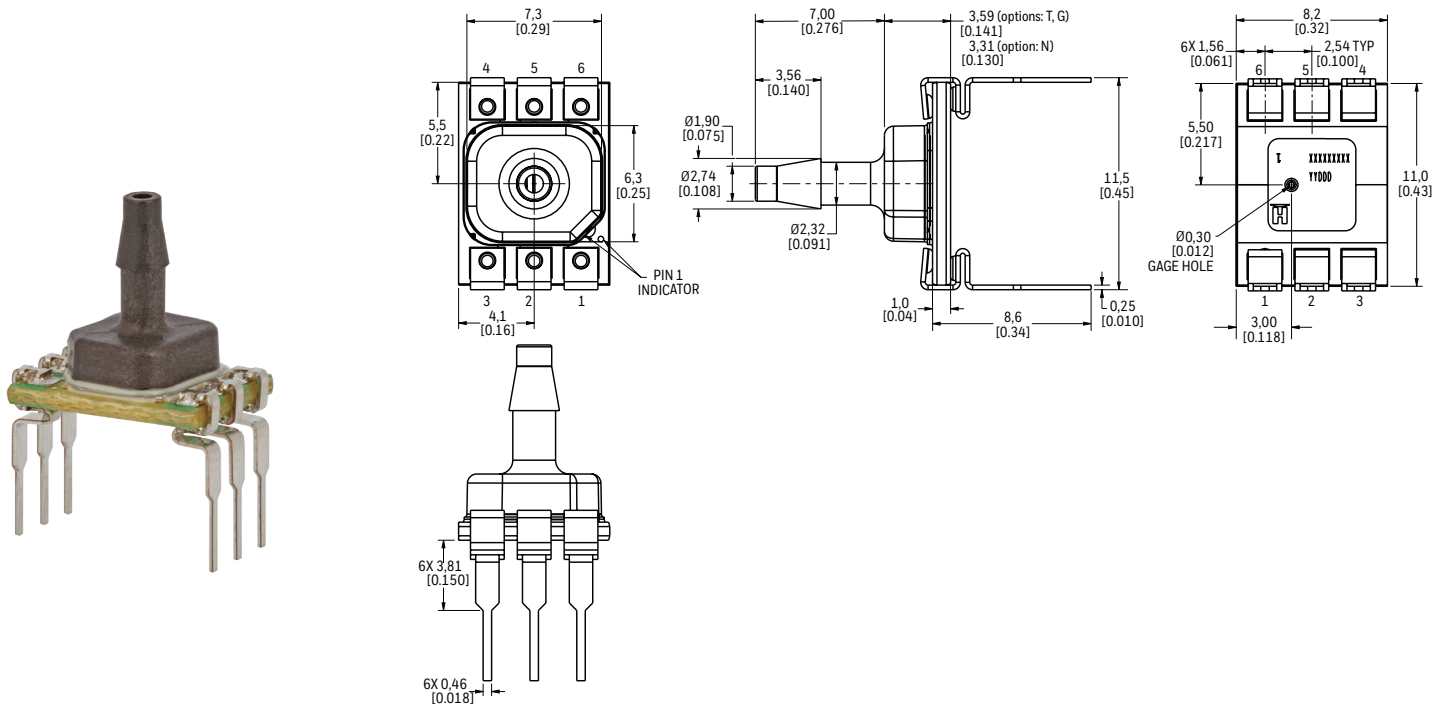

BASIC BOARD-MOUNT PRESSURE SENSORS ABP2 SERIES

Figure 9. DIP Package Dimensional Drawings (Continued)

DIP VN: Metal single axial barbless port

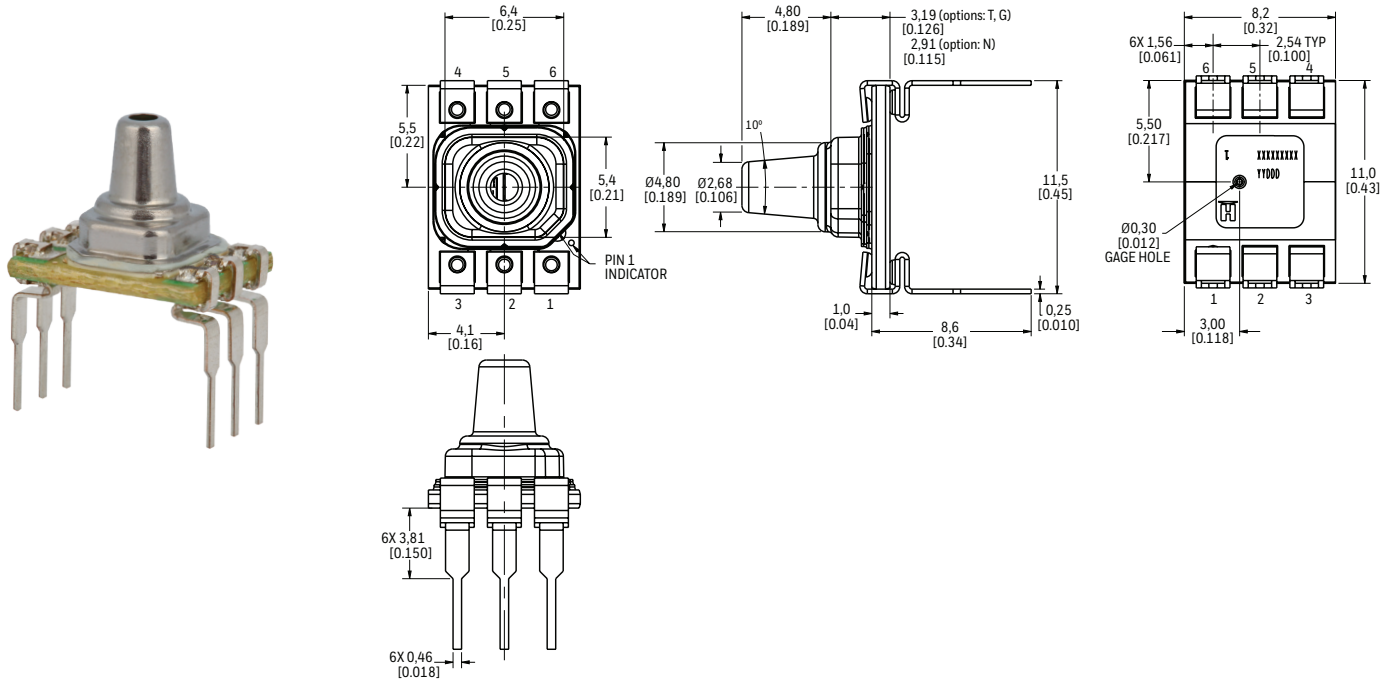

DIP SN: Metal single axial straight barbless port

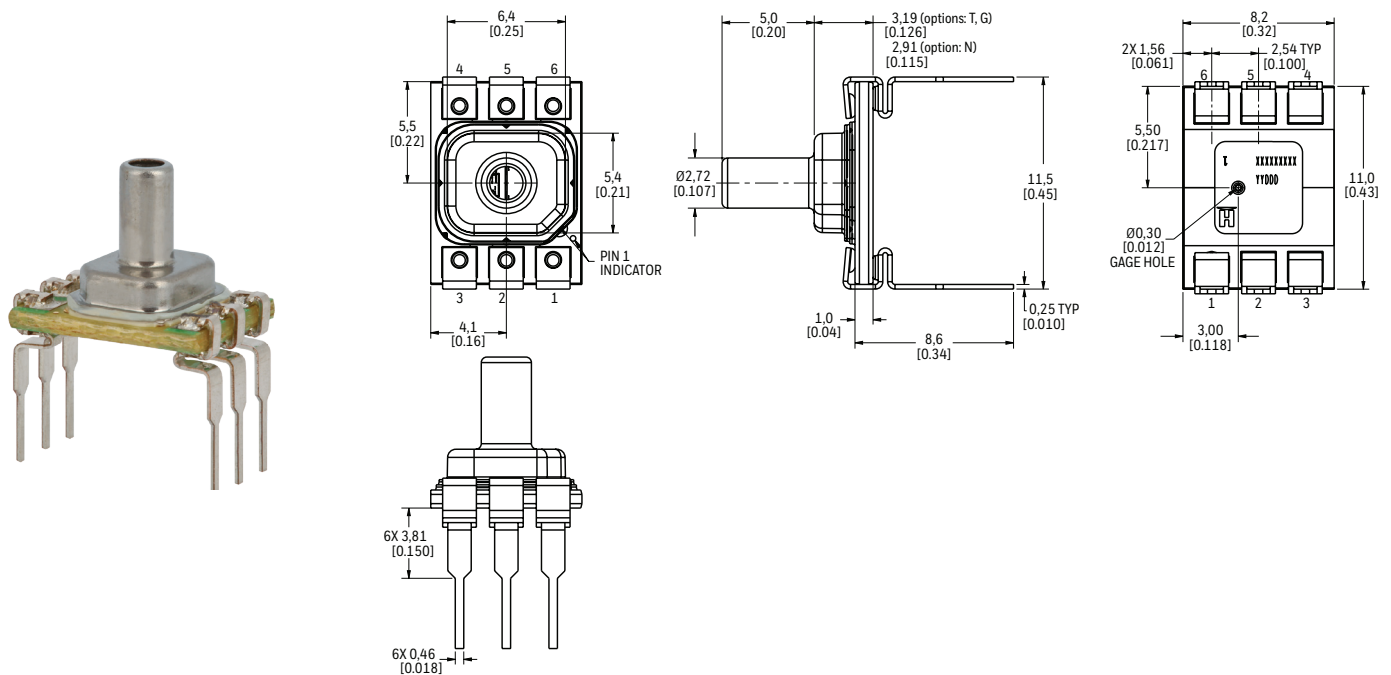

BASIC BOARD-MOUNT PRESSURE SENSORS

ABP2 SERIES

Figure 10. SMT Package Dimensional Drawings (For reference only: mm [in.])

SMT NN: Plastic no port

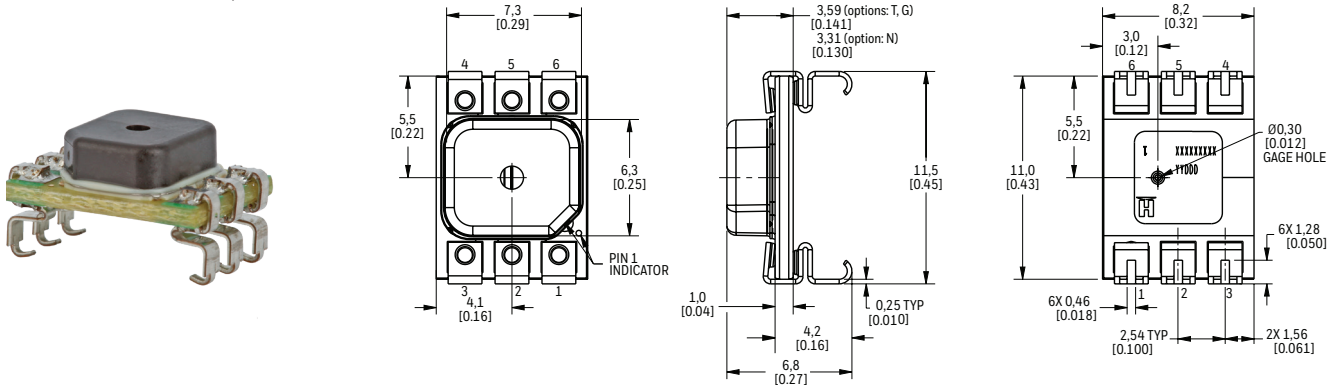

SMT AN: Plastic single axial barbed port

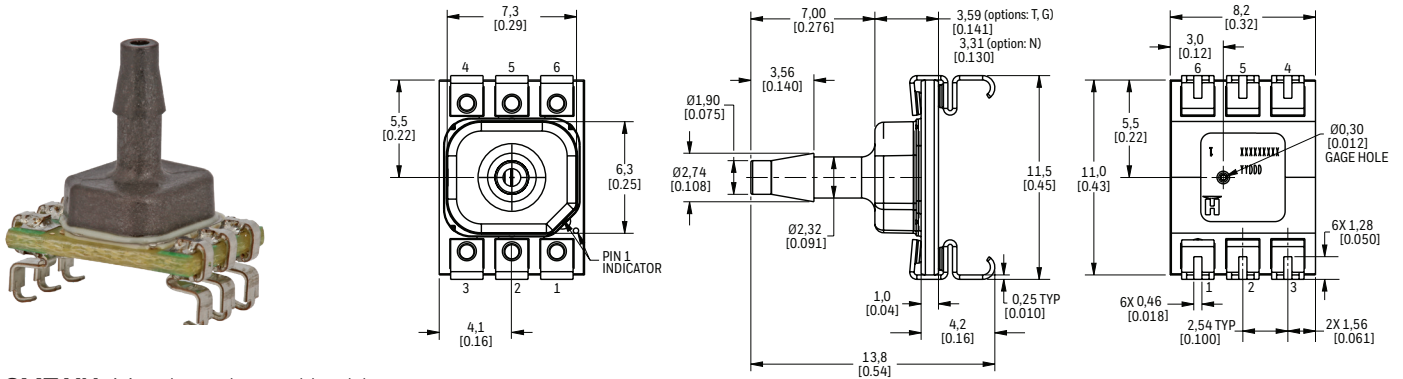

SMT VN: Metal single axial barbless port

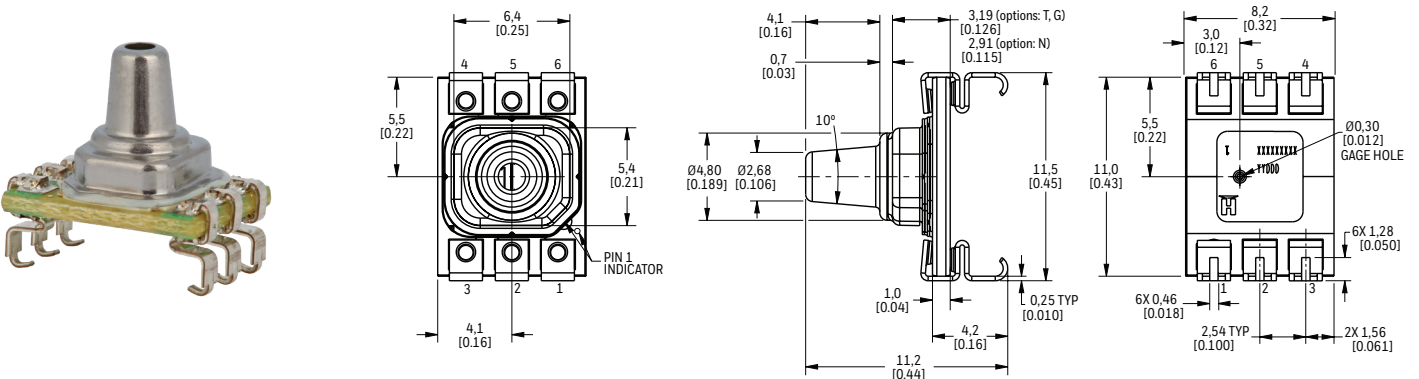

SMT SN: Metal single axial straight barbless port

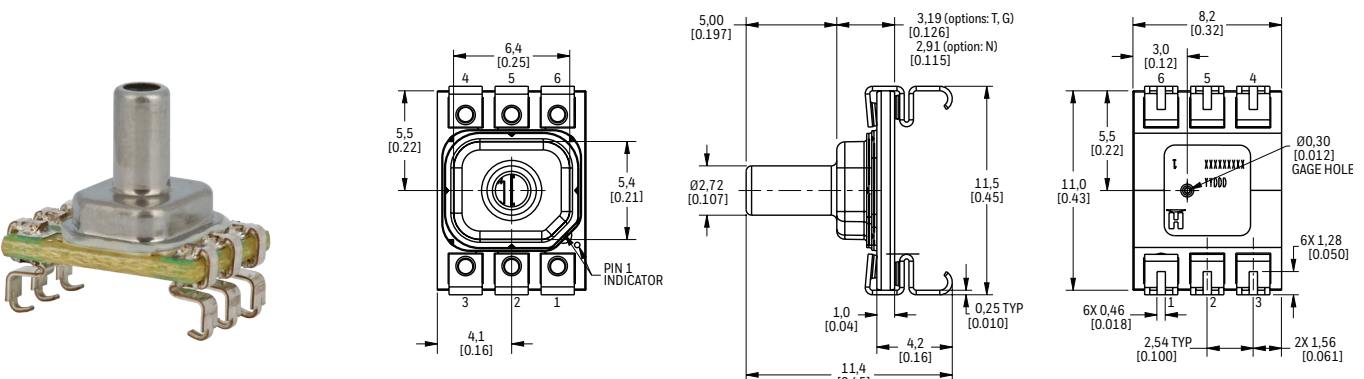

BASIC BOARD-MOUNT PRESSURE SENSORS

ABP2 SERIES

Figure 10. SMT Package Dimensional Drawings (Continued)

SMT RN: Plastic single radial barbed port

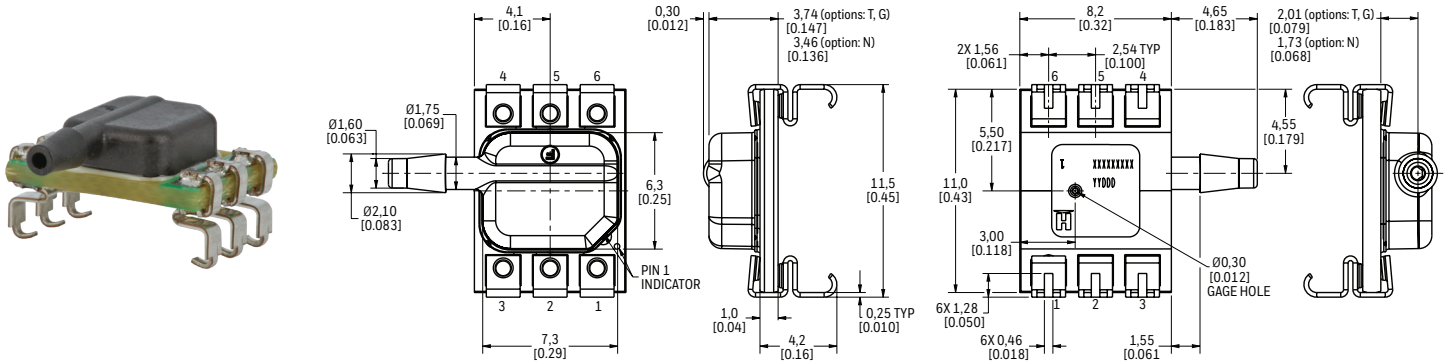

SMT RR: Plastic dual radial barbed ports, same side

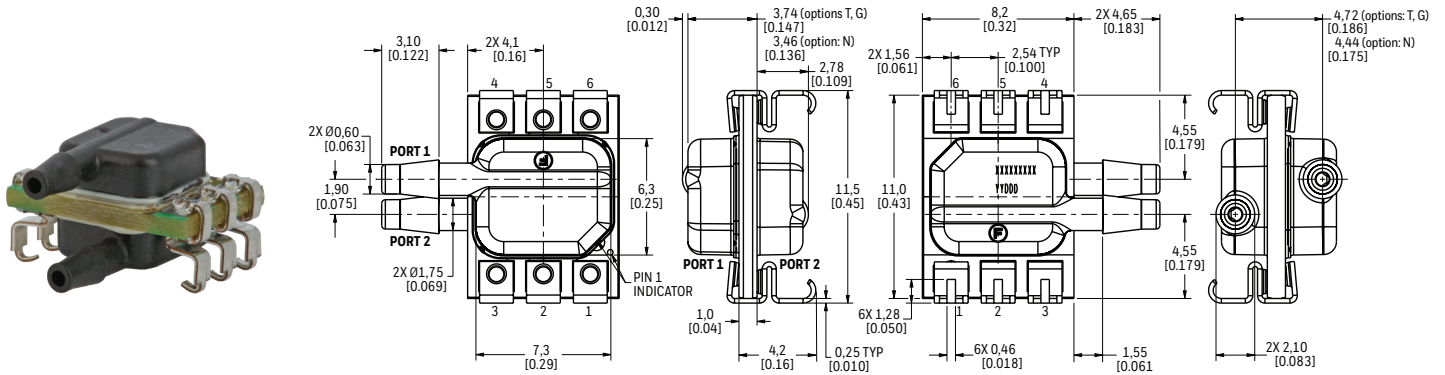

SMT DA: Plastic dual axial barbed ports, same side

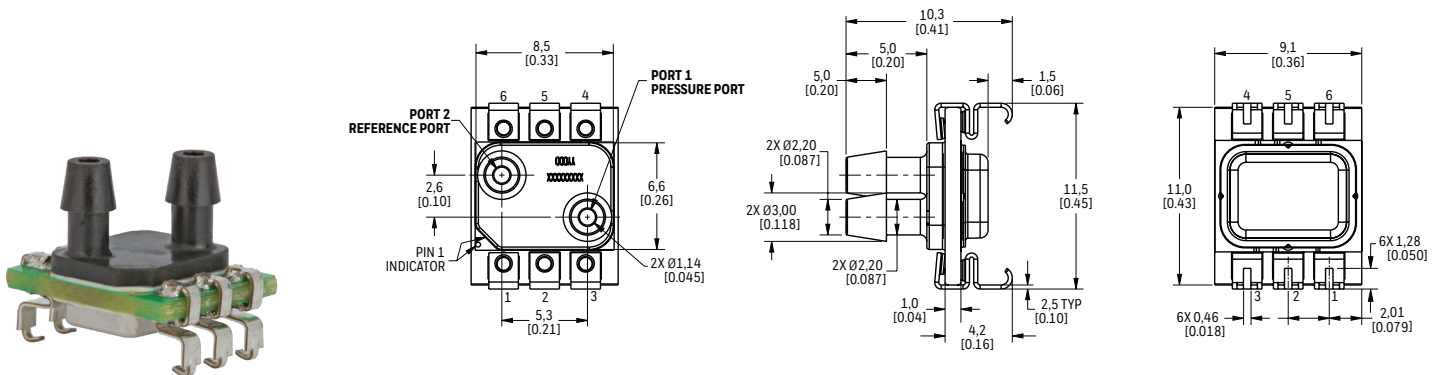

BASIC BOARD-MOUNT PRESSURE SENSORS

ABP2 SERIES

Figure 11. Leadless SMT Package Dimensional Drawings (For Reference Only: mm [in].)

Leadless SMT NN: Plastic no port

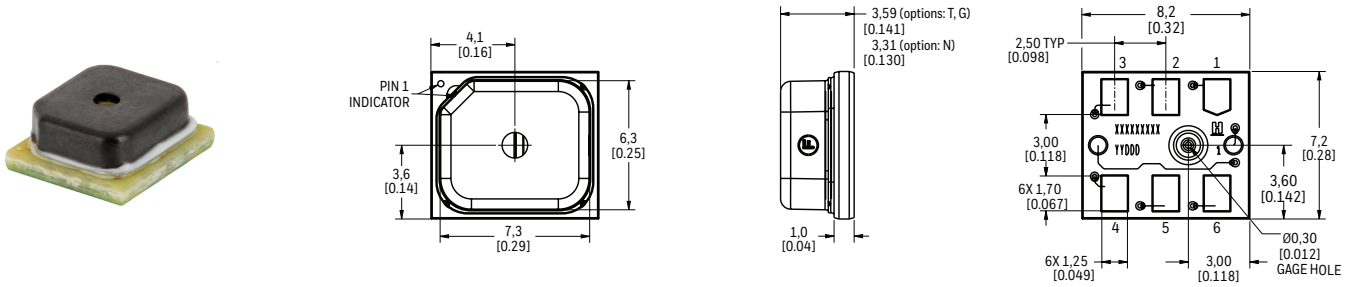

Leadless SMT AN: Plastic single axial barbed port

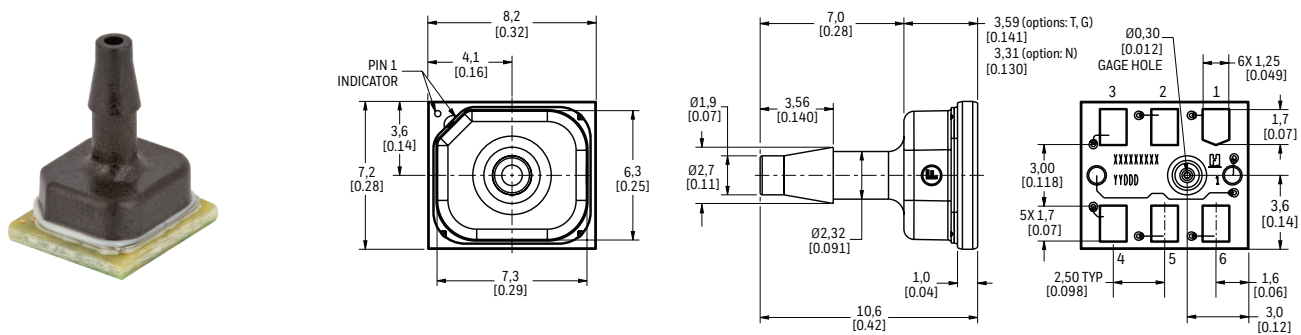

Leadless SMT VN: Metal single axial barbless port

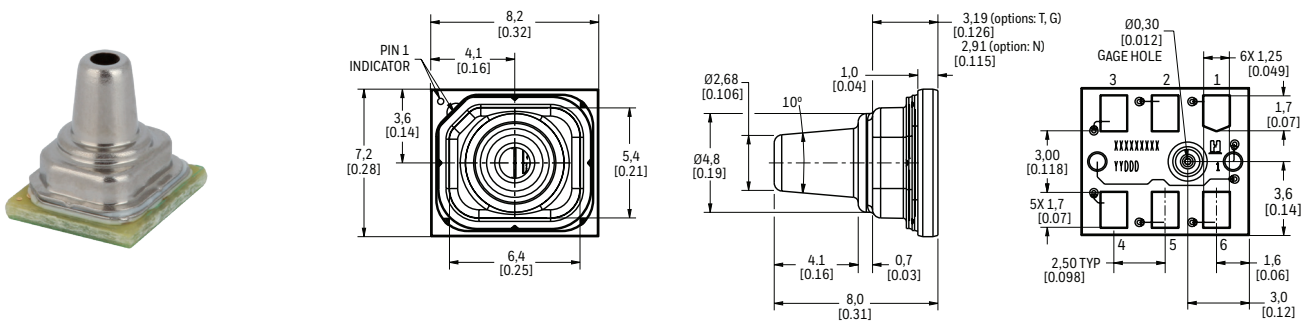

Leadless SMT SN: Metal single axial straight port

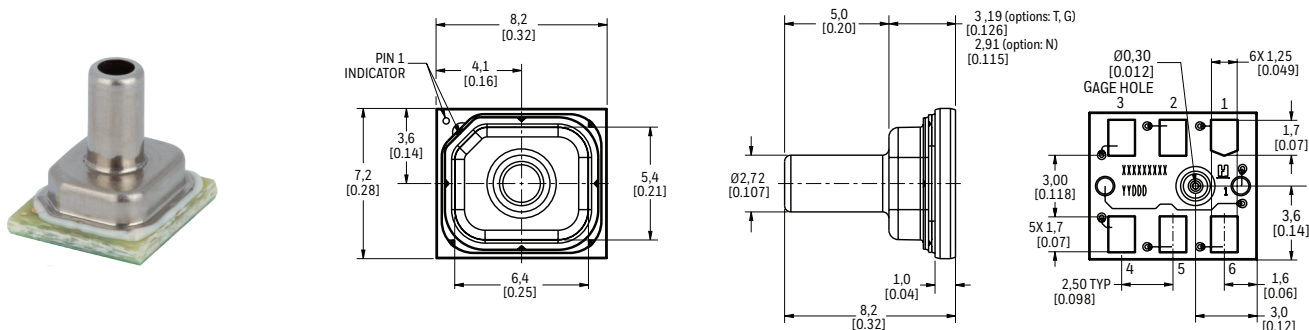

BASIC BOARD-MOUNT PRESSURE SENSORS

ABP2 SERIES

TABLE 19. PINOUT

Output Type	Pin 1	Pin 2	Pin 3	Pin 4	Pin 5	Pin 6
I ² C	GND	V _{DD}	EOC	NC	SDA	SCL
SPI	GND	V _{DD}	MISO	SS	MOSI	SCLK
Analog	GND	NC	V _{OUT}	NC	NC	V _{DD}

Figure 12. Recommended PCB Layout and Part Marketing Details

DIP Packages
All pressure port styles except DA

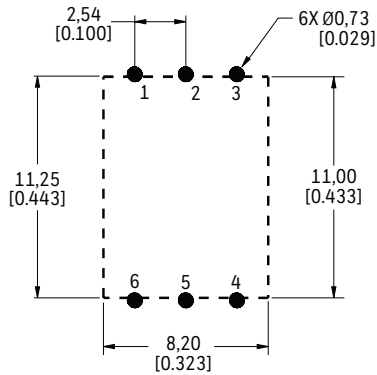

SMT Packages
All pressure port styles except DA

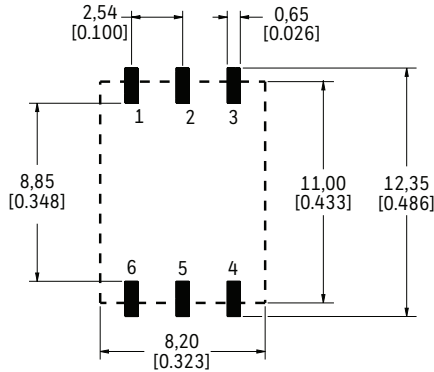

Leadless SMT Packages
All pressure port styles

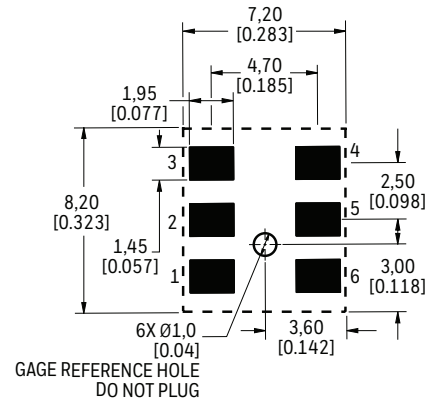

DIP Packages
Pressure port style DA only

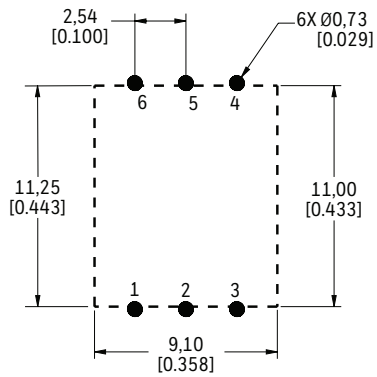

DMT Packages
Pressure port style DA only

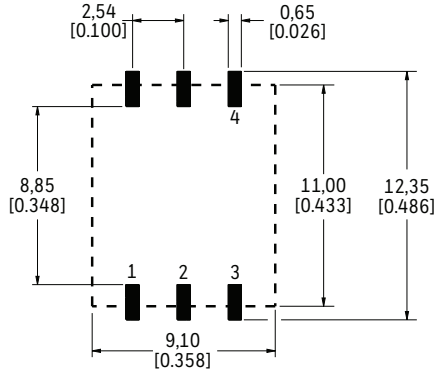

Part Marking Details

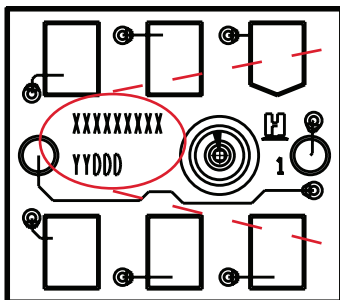

CATALOG LISTING: 'XXXXXXXXX'
 EXAMPLE: N010BAA3
 N - DRY GASES ONLY NO DIAGNOSTICS, 010B - 10bar, A - ABSOLUTE, A - ANALOG,
 A - 10 % to 90 % of 2^24 COUNTS (DIGITAL). 3 - 3.3Vdc
 DATE CODE: 'YYDDD'
 EXAMPLE: 19215
 19 - YY - YEAR, 215 - DDD - JULIAN DAY.

BASIC BOARD-MOUNT PRESSURE SENSORS

ABP2 SERIES

1.0 GENERAL INFORMATION

Please see Figures 7, 8, and 9 for product dimensions and pinout details.

2.0 PINOUT AND FUNCTIONALITY

TABLE 20. PINOUT AND FUNCTIONALITY

Pad Number	I ² C Sensor		SPI Sensor	
	Name	Description	Name	Description
1	GND	Ground reference voltage signal	GND	Ground reference voltage signal
2	V _{DD}	Positive supply voltage	V _{DD}	Positive supply voltage
3	EOC ¹	End-of-conversion indicator: This pin is set high when a measurement and calculation have been completed and the data is ready to be clocked out	MISO	Master In/Sensor Out: Data output
4	NC	No connection	SS	Sensor Select: Chip select
5	SDA	Data in/out	MOSI	Master Out/Sensor In: Data in
6	SCL	Clock input	SCLK	Clock input

¹ For more details on EOC functionality, please refer to the technical note.

3.0 START-UP TIMING

On power-up, the ABP2 Series digital sensor is able to receive the first command after 2.5 ms from when the V_{DD} supply is within operating specifications.

4.0 POWER SUPPLY REQUIREMENT

Verify that system power to the sensor meets the V_{DD} rising slope requirement (minimum V_{DD} rising slope is at least 10 V/ms).

BASIC BOARD-MOUNT PRESSURE SENSORS ABP2 SERIES

5.0 REFERENCE CIRCUIT DESIGNS

5.1 DIGITAL OUTPUT VERSIONS

Figure 13. I²C SPI Circuit Diagram

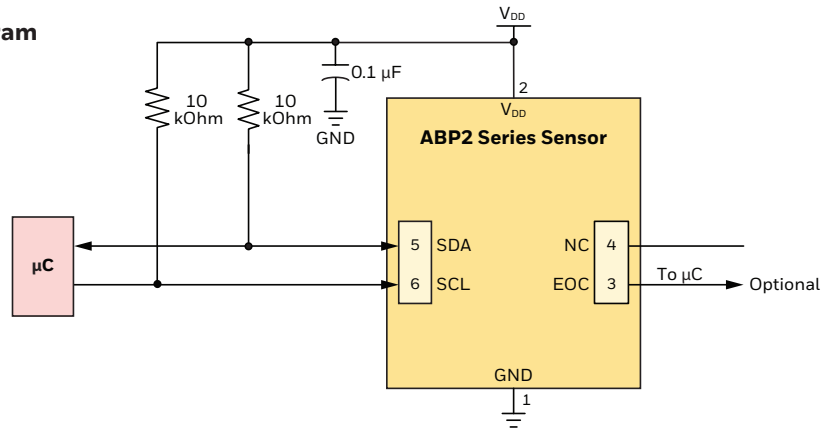
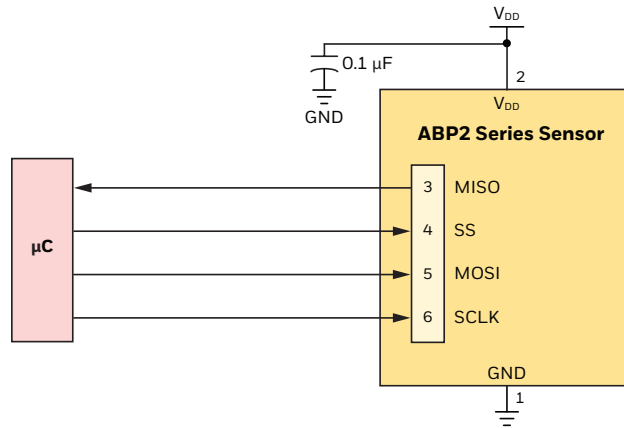
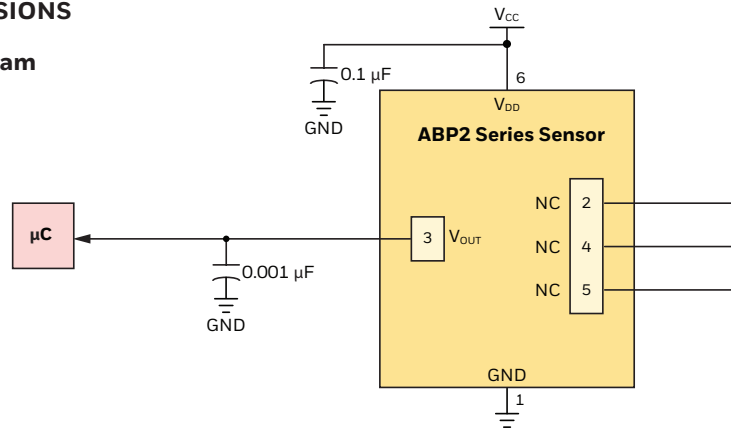

Figure 14. SPI Circuit Diagram



5.2 ANALOG OUTPUT VERSIONS

Figure 15. Analog Circuit Diagram



5.3 BYPASS CAPACITOR USE

NOTICE

To ensure output noise suppression, place an external bypass capacitor of 0.1 µF very close to the sensor power supply pin (see Figures 13 and 14) in the end-user design.

BASIC BOARD-MOUNT PRESSURE SENSORS ABP2 SERIES

6.0 I²C COMMUNICATIONS

6.1 I²C BUS CONFIGURATION (SEE FIGURE 16.)

The I²C bus is a simple, serial 8-bit oriented computer bus for efficient I²C (Inter-IC) control. It provides good support for communication between different ICs across short circuit-board distances, such as interfacing microcontrollers with various low speed peripheral devices. For detailed specifications of the I²C protocol, see Version 6 (April 2014) of the I²C Bus Specification (source: NXP Semiconductor at <https://www.nxp.com/docs/en/user-guide/UM10204.pdf>).

Each device connected to the bus is software addressable by a unique address and a simple Master/Sensor relationship that exists at all times. The output stages of devices connected to the bus are designed around an open collector architecture. Because of this, pull-up resistors to +V_{DD} must be provided on the bus. Both SDA and SCL are bidirectional lines, and it is important to system performance to match the capacitive loads on both lines. In addition, in accordance with the I²C specification, the maximum allowable capacitance on either line is 400 pF to ensure reliable edge transitions at 400 kHz clock speeds.

When the bus is free, both lines are pulled up to +V_{DD}. Data on the I²C bus can be transferred at a rate up to 100 kbit/s in the standard-mode, or up to 400 kbit/s in the fast-mode.

Figure 16. I²C Bus Configuration

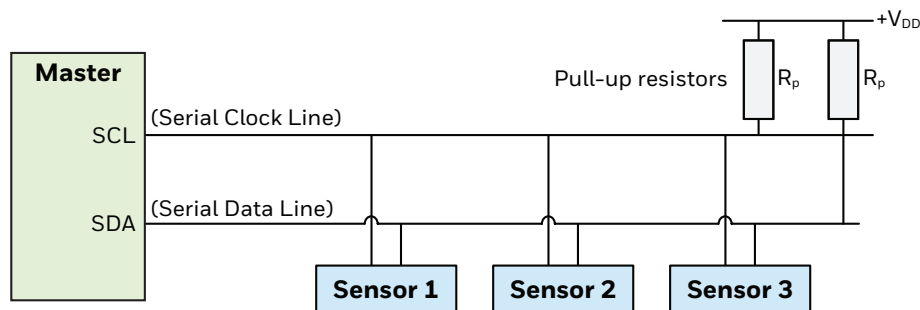

6.2 I²C DATA TRANSFER

The ABP2 Series I²C sensors are designed to respond to requests from a Master device. Following the address and read bit from the Master, the ABP2 Series digital output pressure sensors are designed to output up to 7 bytes of data. The first data byte is the Status Byte (8 bit), the second to fourth bytes are the compensated pressure output (24 bit) and the fifth to seventh bytes are the compensated temperature output (24 bit).

6.3 I²C SENSOR ADDRESS

Each ABP2 Series I²C sensor is referenced on the bus by a 7-bit Sensor address. The default address for the ABP2 Series is 40 (28 hex). Other available standard addresses are: 08 (08 hex), 24 (18 hex), 56 (38 hex), 72 (48 hex), 88 (58 hex), 104 (68 hex), 120 (78 hex). (Other custom values are available. Please contact Honeywell Customer Service with questions regarding custom Sensor addresses.)

6.4 I²C PRESSURE AND TEMPERATURE READING

To read out the compensated pressure and temperature reading, the Master generates a START condition and sends the Sensor address followed by a read bit (1). After the Sensor generates an acknowledge, it will transmit up to 7 bytes of data. The first data byte is the Status Byte (8-bit) and the second to fourth bytes are the compensated pressure output (24 bit) and the fifth to seventh bytes are the compensated temperature output (24 bit). The Master must acknowledge the receipt of each byte, and can terminate the communication by sending a Not Acknowledge (NACK) bit followed by a Stop bit after receiving the required bytes of data.

BASIC BOARD-MOUNT PRESSURE SENSORS ABP2 SERIES

6.5 I²C STATUS BYTE

TABLE 21. I²C STATUS BYTE EXPLANATION

BIT (Meaning)	Status	Comment
7	Always 0	—
6 (Power indication)	1 = device is powered 0 = device is not powered	—
5 (Busy flag)	1 = device is busy	Indicates that the data for the last command is not yet available. No new commands are processed if the device is busy.
4	Always 0	—
3	Always 0	—
2 (Memory integrity/error flag)	0 = integrity test passed 1 = integrity test failed	Indicates whether the checksum-based integrity check passed or failed; the memory error status bit is calculated only during the power-up sequence.
1	Always 0	—
0 (Math saturation)	1 = internal math saturation has occurred	—

6.6 I²C COMMUNICATIONS

6.6.1 I²C OUTPUT MEASUREMENT COMMAND

To communicate with the ABP2 Series I²C output sensor using an Output Measurement Command of “0xAA”, followed by “0x00” “0x00”, follow the steps shown in Table 22. This command will cause the device to exit Standby Mode and enter Operating Mode. At the conclusion of the measurement cycle, the device will automatically re-enter Standby Mode.

TABLE 22. I²C OUTPUT MEASUREMENT COMMAND

Step	Action	Notes
1	<p>7-bit Write bit</p>	<ul style="list-style-type: none"> Master to Sensor Sensor to Master Start condition Stop condition Acknowledge Not acknowledge
2	<p>Option 1: Wait until the busy flag in the Status Byte clears.</p> <p>Option 2: Wait for at least 5 ms for the data conversion to occur.</p> <p>Option 3: Wait for the EOC indicator.</p> <p>7-bit Read bit</p>	
3	<p>To read only the 24-bit pressure output along with the 8-bit Status Byte:</p> <p>7-bit Read bit</p> <p>To read the 24-bit pressure output and 24-bit temperature output along with the 8-bit Status Byte:</p> <p>7-bit Read bit</p>	

BASIC BOARD-MOUNT PRESSURE SENSORS ABP2 SERIES

6.6.2 I²C SENSOR ADDRESS OF 0X28

To communicate with the ABP2 Series I²C output sensor with an I²C Sensor Address of 0x28 (hex), follow the steps shown in Table 23.

TABLE 23. I²C SENSOR ADDRESS OF 0X28 COMMUNICATIONS

Step	Action	Notes
1	<p>0x28 0</p> <p>S SensorAddr 0 A Command A CmdData <15:8> A CmdData <7:0> A P</p> <p>0x50 0xAA 0x00 0x00</p> <p>Write bit</p>	<ul style="list-style-type: none"> Master to Sensor Sensor to Master Start condition Stop condition Acknowledge Not acknowledge
2	<p>Option 1: Wait until the busy flag in the Status Byte clears.</p> <p>Option 2: Wait for at least 5 ms for the data conversion to occur.</p> <p>Option 3: Wait for the EOC indicator.</p> <p>0x28 1</p> <p>S SensorAddr 1 A Status N P</p> <p>0x51</p> <p>Read bit</p>	
3	<p>To read the 24-bit pressure output along with the 8-bit Status Byte:</p> <p>0x28 1</p> <p>S SensorAddr 1 A Status A PressData <23:16> A PressData <15:8> A PressData <7:0> N P</p> <p>0x51</p> <p>Read bit</p> <p>To read the 24-bit pressure output and the 24-bit temperature output along with the 8-bit Status Byte:</p> <p>0x28 1</p> <p>S SensorAddr 1 A Status A PressData <23:16> A PressData <15:8> A PressData <7:0> A TempData <23:16> A TempData <15:8> A TempData <7:0> N P</p> <p>0x51</p> <p>Read bit</p>	

6.7 I²C TIMING AND LEVEL PARAMETERS

TABLE 24. I²C BUS TIMING DIAGRAM AND PARAMETERS

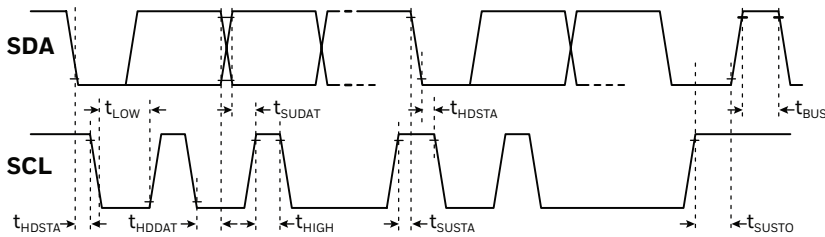

Characteristic	Abbreviation	Min.	Typ.	Max.	Unit
SCL clock frequency	f_{SCL}	100	—	400	kHz
Start condition hold time relative to SCL edge	t_{HDSTA}	0.1	—	—	μ s
Minimum SCL clock low width ¹	t_{LOW}	0.6	—	—	μ s
Minimum SCL clock high width ¹	t_{HIGH}	0.6	—	—	μ s
Start condition setup time relative to SCL edge	t_{SUSTA}	0.1	—	—	μ s
Data hold time on SDA relative to SCL edge	t_{HDDAT}	0	—	—	μ s
Data setup time on SDA relative to SCL edge	t_{SUDAT}	0.1	—	—	μ s
Stop condition setup time on SCL	t_{SUSTO}	0.1	—	—	μ s
Bus free time between stop condition and start condition	t_{BUS}	2	—	—	μ s
Output level low	Out_{low}	—	0	0.2	V_{DD}
Output level high	Out_{high}	0.8	1	—	V_{DD}
Pull-up resistance on SDA and SCL	R_p	1	—	50	k Ω m

¹ Combined low and high widths must equal or exceed minimum SCL period.

BASIC BOARD-MOUNT PRESSURE SENSORS ABP2 SERIES

6.8 REFERENCE CODE (ARDUINO/GENUINO UNO) FOR I²C INTERFACE

See also Section 8.0 for details and examples of ABP2 Series Pressure and Temperature output calculations.

```
#include<Arduino.h>
#include<Wire.h>

uint8_t id = 0x28; // i2c address
uint8_t data[7]; // holds output data
uint8_t cmd[3] = {0xAA, 0x00, 0x00}; // command to be sent
double press_counts = 0; // digital pressure reading [counts]
double temp_counts = 0; // digital temperature reading [counts]
double pressure = 0; // pressure reading [bar, psi, kPa, etc.]
double temperature = 0; // temperature reading in deg C
double outputmax = 15099494; // output at maximum pressure [counts]
double outputmin = 1677722; // output at minimum pressure [counts]
double pmax = 1; // maximum value of pressure range [bar, psi, kPa, etc.]
double pmin = 0; // minimum value of pressure range [bar, psi, kPa, etc.]
double percentage = 0; // holds percentage of full scale data
char printBuffer[200], cBuff[20], percBuff[20], pBuff[20], tBuff[20];
void setup() {
  Serial.begin(9600);
  while (!Serial) {
    delay(10);
  }
  Wire.begin();
  sprintf(printBuffer, "\nStatus Register, 24 - bit Sensor data, Digital Pressure Counts,\
    Percentage of full scale pressure, Pressure Output, Temperature\n");
  Serial.println(printBuffer);
}
void loop() {
  Wire.beginTransmission(id);
  int stat = Wire.write (cmd, 3); // write command to the sensor
  stat |= Wire.endTransmission();
  delay(10);
  Wire.requestFrom(id, 7); // read back Sensor data 7 bytes
  int i = 0;
  for (i = 0; i < 7; i++) {
    data [i] = Wire.read();
  }
  press_counts = data[3] + data[2] * 256 + data[1] * 65536; // calculate digital pressure counts
  temp_counts = data[6] + data[5] * 256 + data[4] * 65536; // calculate digital temperature counts
  temperature = (temp_counts * 200 / 16777215) - 50; // calculate temperature in deg c
  percentage = (press_counts / 16777215) * 100; // calculate pressure as percentage of full scale
  //calculation of pressure value according to equation 2 of datasheet
  pressure = ((press_counts - outputmin) * (pmax - pmin)) / (outputmax - outputmin) + pmin;
  dtostrf(press_counts, 4, 1, cBuff);
  dtostrf(percentage, 4, 3, percBuff);
  dtostrf(pressure, 4, 3, pBuff);
  dtostrf(temperature, 4, 3, tBuff);
  /*
  The below code prints the raw data as well as the processed data
  Data format : Status Register, 24-bit Sensor Data, Digital Counts, percentage of full scale
  pressure,
  pressure output, temperature
  */
  sprintf(printBuffer, " %x\t% 2x % 2x % 2x\t% s\t% s\t% s\t% s \n", data[0], data[1], data[2],
    data[3],
    cBuff, percBuff, pBuff, tBuff);
  Serial.print(printBuffer);
  delay(10);
}
```

BASIC BOARD-MOUNT PRESSURE SENSORS ABP2 SERIES

7.0 SPI COMMUNICATIONS

7.1 SPI DEFINITION

The Serial Peripheral Interface (SPI) is a simple bus system for synchronous serial communication between one Master and one or more Sensors. It operates either in full-duplex or half-duplex mode, allowing communication to occur in either both directions simultaneously, or in one direction only. The Master device initiates an information transfer on the bus and generates clock and control signals. Sensor devices are controlled by the Master through individual Sensors Select (SS) lines and are active only when selected. The ABP2 Series SPI sensors operate in full-duplex mode only, with data transfer from the Sensors to the Master. This data transmission uses four, unidirectional bus lines. The Master controls SCLK, MOSI and SS; the Sensor controls MISO. (See Figure 17.)

Figure 17. SPI Bus Configuration

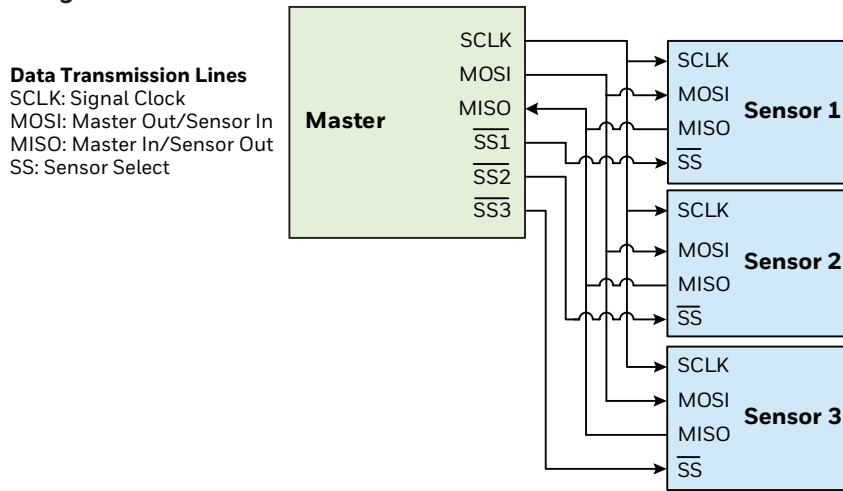

IMPORTANT:

If more than one ABP2 sensor, or other SPI slave devices, or more than one Master, are connected to the same SPI bus, before very first transaction on the SPI bus, bring SS line of each ABP2 sensor from High state to Low state, hold the Low state for minimum of 200 us, and release it to High state.

7.2 SPI DATA TRANSFER

Communicate with the ABP2 Series SPI sensors by de-asserting the Sensor Select (SS) line. At this point, the sensor is no longer idle, and will begin sending data once a clock is received. ABP2 Series SPI sensors are configured for SPI operation in mode 0 (clock polarity is 0 and clock phase is 0). (See Figure 18.)

Figure 18. Example of 1 Byte SPI Data Transfer

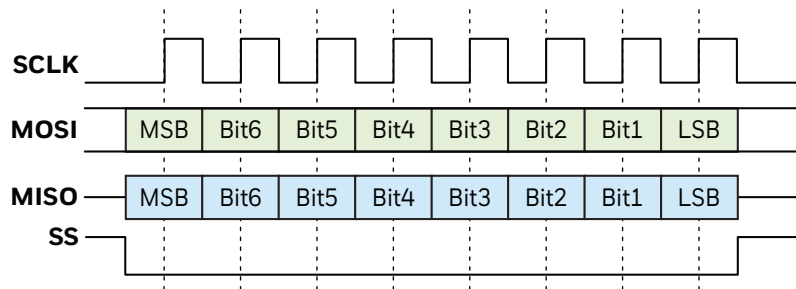

Once the clocking begins, the ABP2 Series SPI sensor is designed to output up to 7 bytes of data. The first data byte is the Status Byte (8-bit), the second to fourth bytes are the compensated pressure output (24-bit) and the fifth to seventh bytes are the compensated temperature output (24-bit).

BASIC BOARD-MOUNT PRESSURE SENSORS

ABP2 SERIES

7.3 SPI PRESSURE AND TEMPERATURE READING

To read out the compensated pressure and temperature reading, the Master generates the necessary clock signal after activating the sensor with the Sensor Select (SS) line. The sensor will transmit up to 7 bytes of data. The first data byte is the Status Byte (8-bit), the second to fourth bytes are the compensated pressure output (24-bit) and the fifth to seventh bytes are the compensated temperature output (24-bit). The Master can terminate the communication by stopping the clock and deactivating the SS line.

7.4 SPI STATUS BYTE

The SPI status byte contains the bits shown in Table 25.

TABLE 25. SPI STATUS BYTE EXPLANATION

Bit (Meaning)	Status	Comment
7	Always 0	—
6 (Power indication)	1 = device is powered 0 = device is not powered	—
5 (Busy flag)	1 = device is busy	Indicates that the data for the last command is not yet available. No new commands are processed if the device is busy.
4	Always 0	—
3	Always 0	—
2 (Memory integrity/error flag)	0 = integrity test passed 1 = integrity test failed	Indicates whether the checksum-based integrity check passed or failed; the memory error status bit is calculated only during the power-up sequence.
1	Always 0	—
0 (Math saturation)	1 = internal math saturation has occurred	—

BASIC BOARD-MOUNT PRESSURE SENSORS ABP2 SERIES

7.5 SPI COMMUNICATION

To communicate with the ABP2 Series SPI output sensor using an Output Measurement Command of “0xAA”, followed by “0x00” “0x00”, follow the steps shown in Table 26. This command will cause the device to exit Standby Mode and enter Operating Mode. At the conclusion of the measurement cycle, the device will automatically re-enter Standby Mode.

TABLE 26. SPI OUTPUT MEASUREMENT COMMAND

Step	Action	Notes																					
1	The data on MISO depend on the preceding command. Discard the data on the MISO line.	<div style="display: flex; flex-direction: column; align-items: flex-start;"> <div style="margin-bottom: 10px;"> Master to Sensor</div> <div style="margin-bottom: 10px;"> Sensor to Master</div> <ul style="list-style-type: none"> NOP Command is “0xF0”. </div>																					
	<table border="1" style="margin-left: 20px;"> <tr> <td style="width: 40px;">0xAA</td> <td style="width: 40px;">0x00</td> <td style="width: 40px;">0x00</td> </tr> <tr> <td style="background-color: #d9ead3;">Measurement Command</td> <td style="background-color: #d9ead3;">CmdData <15:8></td> <td style="background-color: #d9ead3;">CmdData <7:0></td> </tr> <tr> <td style="background-color: #d9ead3;">MISO</td> <td style="background-color: #d9ead3;">Status</td> <td style="background-color: #d9ead3;">Data</td> </tr> </table>		0xAA	0x00	0x00	Measurement Command	CmdData <15:8>	CmdData <7:0>	MISO	Status	Data												
	0xAA		0x00	0x00																			
Measurement Command	CmdData <15:8>	CmdData <7:0>																					
MISO	Status	Data																					
<table border="1" style="margin-left: 20px;"> <tr> <td style="width: 40px;">0xF0</td> <td style="width: 40px;">0x00</td> <td style="width: 40px;">0x00</td> <td style="width: 40px;">0x00</td> </tr> <tr> <td style="background-color: #d9ead3;">Command = NOP</td> <td style="background-color: #d9ead3;">00_{Hex}</td> <td style="background-color: #d9ead3;">00_{Hex}</td> <td style="background-color: #d9ead3;">00_{Hex}</td> </tr> <tr> <td style="background-color: #d9ead3;">MISO</td> <td style="background-color: #d9ead3;">Status</td> <td style="background-color: #d9ead3;">PressData <24:16></td> <td style="background-color: #d9ead3;">PressData <15:8></td> </tr> </table>	0xF0	0x00	0x00	0x00	Command = NOP	00 _{Hex}	00 _{Hex}	00 _{Hex}	MISO	Status	PressData <24:16>	PressData <15:8>											
0xF0	0x00	0x00	0x00																				
Command = NOP	00 _{Hex}	00 _{Hex}	00 _{Hex}																				
MISO	Status	PressData <24:16>	PressData <15:8>																				
2	<p>Option 1: Wait until the busy flag in the Status Byte clears. Option 2: Wait for at least 5 ms for the data conversion to occur.</p> <table border="1" style="margin-left: 20px;"> <tr> <td style="width: 40px;">0xF0</td> <td style="width: 40px;">0x00</td> <td style="width: 40px;">0x00</td> <td style="width: 40px;">0x00</td> </tr> <tr> <td style="background-color: #d9ead3;">Command = NOP</td> <td style="background-color: #d9ead3;">00_{Hex}</td> <td style="background-color: #d9ead3;">00_{Hex}</td> <td style="background-color: #d9ead3;">00_{Hex}</td> </tr> <tr> <td style="background-color: #d9ead3;">MISO</td> <td style="background-color: #d9ead3;">Status</td> <td style="background-color: #d9ead3;">PressData <24:16></td> <td style="background-color: #d9ead3;">PressData <15:8></td> </tr> </table>	0xF0	0x00	0x00	0x00	Command = NOP	00 _{Hex}	00 _{Hex}	00 _{Hex}	MISO	Status	PressData <24:16>	PressData <15:8>										
0xF0	0x00	0x00	0x00																				
Command = NOP	00 _{Hex}	00 _{Hex}	00 _{Hex}																				
MISO	Status	PressData <24:16>	PressData <15:8>																				
3	To read only the 24-bit pressure output along with the 8-bit Status Byte:																						
	<table border="1" style="margin-left: 20px;"> <tr> <td style="width: 40px;">0xF0</td> <td style="width: 40px;">0x00</td> <td style="width: 40px;">0x00</td> <td style="width: 40px;">0x00</td> </tr> <tr> <td style="background-color: #d9ead3;">Command = NOP</td> <td style="background-color: #d9ead3;">00_{Hex}</td> <td style="background-color: #d9ead3;">00_{Hex}</td> <td style="background-color: #d9ead3;">00_{Hex}</td> </tr> <tr> <td style="background-color: #d9ead3;">MISO</td> <td style="background-color: #d9ead3;">Status</td> <td style="background-color: #d9ead3;">PressData <24:16></td> <td style="background-color: #d9ead3;">PressData <15:8></td> </tr> </table>	0xF0	0x00	0x00	0x00	Command = NOP	00 _{Hex}	00 _{Hex}	00 _{Hex}	MISO	Status	PressData <24:16>	PressData <15:8>										
	0xF0	0x00	0x00	0x00																			
Command = NOP	00 _{Hex}	00 _{Hex}	00 _{Hex}																				
MISO	Status	PressData <24:16>	PressData <15:8>																				
To read the 24-bit pressure output and the 24-bit temperature output along with the 8-bit Status Byte:																							
<table border="1" style="margin-left: 20px;"> <tr> <td style="width: 40px;">0xF0</td> <td style="width: 40px;">0x00</td> <td style="width: 40px;">0x00</td> <td style="width: 40px;">0x00</td> <td style="width: 40px;">0x00</td> <td style="width: 40px;">0x00</td> <td style="width: 40px;">0x00</td> </tr> <tr> <td style="background-color: #d9ead3;">Command = NOP</td> <td style="background-color: #d9ead3;">00_{Hex}</td> <td style="background-color: #d9ead3;">00_{Hex}</td> <td style="background-color: #d9ead3;">00_{Hex}</td> <td style="background-color: #d9ead3;">00_{Hex}</td> <td style="background-color: #d9ead3;">00_{Hex}</td> <td style="background-color: #d9ead3;">00_{Hex}</td> </tr> <tr> <td style="background-color: #d9ead3;">MISO</td> <td style="background-color: #d9ead3;">Status</td> <td style="background-color: #d9ead3;">PressData <24:16></td> <td style="background-color: #d9ead3;">PressData <15:8></td> <td style="background-color: #d9ead3;">PressData <7:0></td> <td style="background-color: #d9ead3;">TempData <24:16></td> <td style="background-color: #d9ead3;">TempData <15:8></td> </tr> </table>	0xF0	0x00	0x00	0x00	0x00	0x00	0x00	Command = NOP	00 _{Hex}	00 _{Hex}	00 _{Hex}	00 _{Hex}	00 _{Hex}	00 _{Hex}	MISO	Status	PressData <24:16>	PressData <15:8>	PressData <7:0>	TempData <24:16>	TempData <15:8>		
0xF0	0x00	0x00	0x00	0x00	0x00	0x00																	
Command = NOP	00 _{Hex}	00 _{Hex}	00 _{Hex}	00 _{Hex}	00 _{Hex}	00 _{Hex}																	
MISO	Status	PressData <24:16>	PressData <15:8>	PressData <7:0>	TempData <24:16>	TempData <15:8>																	

BASIC BOARD-MOUNT PRESSURE SENSORS

ABP2 SERIES

7.6 SPI TIMING AND LEVEL PARAMETERS

TABLE 27. SPI BUS TIMING DIAGRAM AND PARAMETERS

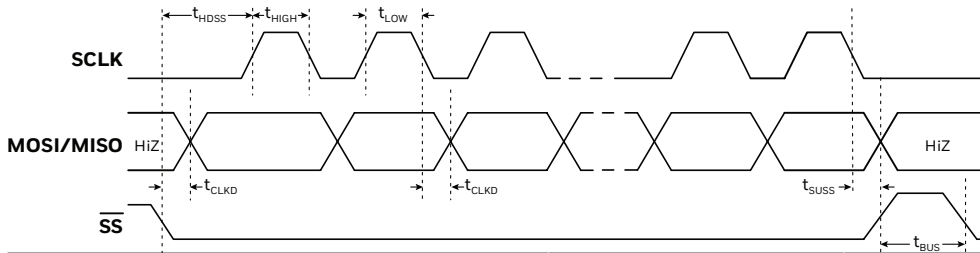

Characteristic	Abbreviation	Min.	Typ.	Max.	Unit
SCLK clock frequency	f _{SCLK}	50	—	800	kHz
SS drop to first clock edge	t _{HDSS}	2.5	—	—	μs
Minimum SCLK clock low width ¹	t _{LOW}	0.6	—	—	μs
Minimum SCLK clock high width ¹	t _{HIGH}	0.6	—	—	μs
Clock edge to data transition	t _{CLKD}	0	—	—	μs
Rise of SS relative to last clock edge	t _{SUSS}	0.1	—	—	μs
Bus free time between rise and fall of SS	t _{BUS}	2	—	—	μs
Output level low	Out _{low}	—	0	0.2	V _{DD}
Output level high	Out _{high}	0.8	1	—	V _{DD}

¹Combined low and high widths must equal or exceed minimum SCLK period.

BASIC BOARD-MOUNT PRESSURE SENSORS

ABP2 SERIES

7.7 REFERENCE CODE (ARDUINO/GENUINO UNO) FOR SPI INTERFACE

See also Section 8.0 for details and examples of ABP2 Series Pressure and Temperature output calculations.

```
#include<Arduino.h>
#include<SPI.h>

double press_counts = 0; // digital pressure reading [counts]
double temp_counts = 0; // digital temperature reading [counts]
double pressure = 0; // pressure reading [bar, psi, kPa, etc.]
double temperature = 0; // temperature reading in deg C
double outputmax = 15099494; // output at maximum pressure [counts]
double outputmin = 1677722; // output at minimum pressure [counts]
double pmax = 1; // maximum value of pressure range [bar, psi, kPa, etc.]
double pmin = 0; // minimum value of pressure range [bar, psi, kPa, etc.]
double percentage = 0; // holds percentage of full scale data
char printBuffer[200], cBuff[20], percBuff[20], pBuff[20], tBuff[20];
void setup() {
  Serial.begin(9600);
  while (!Serial) {
    delay(10);
  }
  sprintf(printBuffer, "\nStatus Register, 24-bit Sensor data, Digital Pressure Counts,\
Percentage of full scale pressure,Pressure Output, Temperature\n");
  Serial.println(printBuffer);
  SPI.begin();
  pinMode(10, OUTPUT); // pin 10 as SS
  digitalWrite(10, HIGH); // set SS High
}
void loop() {
  delay(1);
  while (1) {
    uint8_t data[7] = {0xF0, 0x00, 0x00, 0x00, 0x00, 0x00, 0x00}; // holds output data
    uint8_t cmd[3] = {0xAA, 0x00, 0x00}; // command to be sent
    SPI.beginTransaction(SPISettings(200000, MSBFIRST, SPI_MODE0)); //SPI at 200kHz
    digitalWrite(10, LOW); // set SS Low
    SPI.transfer(cmd, 3); // send Read Command
    digitalWrite(10, HIGH); // set SS High
    delay(10); // wait for conversion
    digitalWrite(10, LOW);
    SPI.transfer(data, 7);
    digitalWrite(10, HIGH);
    SPI.endTransaction();
    press_counts = data[3] + data[2] * 256 + data[1] * 65536; // calculate digital pressure counts
    temp_counts = data[6] + data[5] * 256 + data[4] * 65536; // calculate digital temperature counts
    temperature = (temp_counts * 200 / 16777215) - 50; // calculate temperature in deg c
    percentage = (press_counts / 16777215) * 100; // calculate pressure as percentage of full scale
    //calculation of pressure value according to equation 2 of datasheet
    pressure = ((press_counts - outputmin) * (pmax - pmin)) / (outputmax - outputmin) + pmin;
    dtostrf(press_counts, 4, 1, cBuff);
    dtostrf(percentage, 4, 3, percBuff);
    dtostrf(pressure, 4, 3, pBuff);
    dtostrf(temperature, 4, 3, tBuff);
    /*
     * The below code prints the raw data as well as the processed data
     * Data format : Status Register, 24-bit Sensor Data, Digital Counts, percentage of full scale pressure,
     * pressure output,
     * temperature
     */
    sprintf(printBuffer, "%x\t%2x %2x %2x\t%s\t%s\t%s\t%s \n", data[0], data[1], data[2], data[3],
      cBuff, percBuff, pBuff, tBuff);
    Serial.print(printBuffer);
    delay(10);
  }
}
press_counts = (double)((int32_t)data[3]+(int32_t)data[2]*(int32_t)256+ (int32_t)data[1]*(int32_t)65536);
```

BASIC BOARD-MOUNT PRESSURE SENSORS ABP2 SERIES

8.0 ABP2 SERIES CALCULATIONS

8.1 DIGITAL OUTPUT VERSIONS

8.1.1 Pressure Output

The ABP2 Series sensor pressure output may be expressed by the transfer function of the device as shown in Equation 1:

Equation 1: Pressure Sensor Transfer Function

$$\text{Output} = \frac{\text{Output}_{\text{max.}} - \text{Output}_{\text{min.}}}{P_{\text{max.}} - P_{\text{min.}}} * (\text{Pressure} - P_{\text{min.}}) + \text{Output}_{\text{min.}}$$

Rearranging this equation to solve for Pressure provides Equation 2:

Equation 2: Pressure Output Function

$$\text{Pressure} = \frac{(\text{Output} - \text{Output}_{\text{min.}}) * (P_{\text{max.}} - P_{\text{min.}})}{\text{Output}_{\text{max.}} - \text{Output}_{\text{min.}}} + P_{\text{min.}}$$

Where:

Output_{max.} = output at maximum pressure [counts]

Output_{min.} = output at minimum pressure [counts]

P_{max.} = maximum value of pressure range [bar, psi, kPa, etc.]

P_{min.} = minimum value of pressure range [bar, psi, kPa, etc.]

Pressure = pressure reading [bar, psi, kPa, etc.]

Output = digital pressure reading [counts]

Example: Calculate the pressure for a -1 psi to 1 psi gage sensor with a 10 to 90 calibration, and a pressure output of 14260634 (decimal) counts:

Output_{max.} = 15099494 counts (90 of 2²⁴ counts or 0xE66666)

Output_{min.} = 1677722 counts (10 of 2²⁴ counts or 0x199999A)

P_{max.} = 1 psi

P_{min.} = -1 psi

Pressure = calculated pressure in psi

Output = 14260634 counts

$$\text{Pressure} = \left(\frac{(2.805 - 0.33 * (1 - (-1)))}{2.97 - 0.33} \right) + (-1)$$

$$\text{Pressure} = \left(\frac{25165824}{13421772} \right) + (-1)$$

Pressure = 0.875 psi

BASIC BOARD-MOUNT PRESSURE SENSORS

ABP2 SERIES

8.1.2 Temperature Output

The ABP2 Series sensor temperature output may be expressed by the transfer function of the device as shown in Equation 3:

Equation 3: Temperature Output Transfer Function

$$\text{Temperature} = \frac{T_{\text{out}} * (T_{\text{max.}} - T_{\text{min.}})}{(2^{(24)} - 1)} + T_{\text{min.}}$$

Where:

Temperature = calculated temperature output in °C

T_{out} = digital temperature output in counts (decimal)

T_{max.} = 150°C

T_{min.} = -50°C

Example: Calculate the temperature for a temperature output of 6291456 (decimal) counts.

$$\text{Temperature} = \frac{T_{\text{out}} * (150 - (-50))}{(2^{(24)} - 1)} + T_{\text{min.}}$$

$$\text{Temperature} = \frac{6291456 * 200}{16777215} - 50$$

$$\text{Temperature} = 25^{\circ}\text{C}$$

BASIC BOARD-MOUNT PRESSURE SENSORS

ABP2 SERIES

8.2 ANALOG OUTPUT VERSIONS

The ABP2 Series sensor temperature output may be expressed by the transfer function of the device as shown in Equation 1:

Equation 1: Pressure Output Transfer Function

$$\text{Output} = \frac{\text{Output}_{\text{max.}} - \text{Output}_{\text{min.}}}{P_{\text{max.}} - P_{\text{min.}}} * (\text{Pressure} - P_{\text{min.}}) + \text{Output}_{\text{min.}}$$

$$\text{Pressure} = \frac{(\text{Output} - \text{Output}_{\text{min.}}) * (P_{\text{max.}} - P_{\text{min.}})}{\text{Output}_{\text{max.}} - \text{Output}_{\text{min.}}} + P_{\text{min.}}$$

Where:

Output_{max.} = output at maximum pressure [Vdc]

Output_{min.} = output at minimum pressure [Vdc]

P_{max.} = maximum value of pressure range [bar, psi, kPa, etc.]

P_{min.} = minimum value of pressure range [bar, psi, kPa, etc.]

Pressure = pressure reading [bar, psi, kPa, etc.]

Output = digital pressure reading [Vdc]

Example: Calculate the pressure for a -1 psi to 1 psi gage sensor with a 10 % to 90 % calibration, and a pressure output of 2.805 Vdc at 3.3 Vdc supply voltage:

Output_{max.} = 2.97 Vdc (90 % of V_{supply})

Output_{min.} = 0.33 Vdc (10 % of V_{supply})

P_{max.} = 1 psi

P_{min.} = -1 psi

Pressure = pressure in psi

Output = 2.805 Vdc

$$\text{Pressure} = \left(\frac{(2.805 - 0.33) * (1 - (-1))}{2.97 - 0.33} \right) + (-1)$$

$$\text{Pressure} = \left(\frac{4.95}{2.64} \right) - 1$$

Pressure = 0.875 psi

BASIC BOARD-MOUNT PRESSURE SENSORS

ABP2 SERIES

9.0 RECOMMENDED PNEUMATIC SENSOR CONNECTIONS

9.1 TUBING

Tubing is a common method of pneumatically connecting to the sensors and needs to be matched to the sensor's application to provide the required operating temperature range and working pressure. Depending on the working pressure range and operating temperature, the corresponding type of tubing can be selected (i.e., Superthane®, silicone, and vinyl). Silicone tubing, for instance, tends to be the easiest to which to connect; however, its working pressure is not as high as that of the other materials.

The lower the shore rating for the tubing, the easier it is to insert the tubing onto the sensor's pressure port; however, the lower shore rated tubing also has lower working pressures. For working pressures of 20 psi and below, silicone or vinyl tubing tends to be used. For pressures above 20 psi, Superthane® or low-density polyethylene tubing may be considered. Table 28 shows recommended tubing for use with Honeywell Basic Board Mount Pressure Sensors.

Generally, when the working pressure is 15 psi or less, clamps are typically not required. However, because each application is different, the end use must be taken into account before determining whether clamps are necessary to ensure that the tubing remains in place and doesn't leak. Considerations include vibration, pressure spikes, and the type of tubing being used. A common clamping method is to use a plastic cable tie, available in a variety of sizes and found in most hardware stores. They are relatively easy to install and stay in place over time.

NOTICE

Instead of using a clamp, a small drop of epoxy may be applied to either pressure port prior to the tubing being placed onto the port or applied at the end of the tubing once the tubing is in place. This method holds the tubing in place and can further act as a sealing agent to help ensure a leak-tight connection between the pressure port and the tubing. A room temperature sealant is generally used for this purpose. Ensure that the epoxy doesn't block the hole in the port as it needs to remain open.

NOTICE

To apply a more rigid tubing-to-port connection, a low-power heat gun may be used to slightly heat the tubing. Once cooled, the tubing tends to grip the pressure port better.

TABLE 28. RECOMMENDED TUBING

Pressure Port	Manufacturer	Type	Part Number	ID	OD	Pressure at 25°C (psi)
AN	Frelin-Wade	Fre-Thane® (polyurethane)	1A-156-11	0.093 in	0.156 in	210
AN	Frelin-Wade	nylon	1A-200-01	0.093 in	0.125 in	270
AN	NewAge Industries	PVC	1100225	0.094 in	0.156 in	42
AN	NewAge Industries	silicone	2800315	0.094 in	0.156 in	20
AN	McMaster	silicone	5041K512	2,0 mm	6,0 mm	60
AN	McMaster	silicone	5041K601	2,0 mm	6,0 mm	115
RN, RR	Frelin-Wade	Fre-Thane	95a-157	0.066 in	0.125 in	225
RN, RR	NewAge Industries	Superthane® (ether)	2110535	0.066 in	0.125 in	135
RN	NewAge Industries	silicone	2800161	0.063 in	0,188 in	20
RN, RR	Du-Bro	silicone	196 1/16 ID	0.063 in	0.125 in	20
RN, RR	US Plastics	Excelthane polyurethane	77901710	0.063 in	0.125 in	70
RN, RR	McMaster	silicone	5041K603	1,0 mm	3.00 in	15
DA	McMaster	silicone	5041K512	2,0 mm	6,0 mm	60

BASIC BOARD-MOUNT PRESSURE SENSORS ABP2 SERIES

9.2 O-RING MANIFOLD DESIGNS

O-rings may also be used to connect pneumatically to the sensor. Most O-ring manufacturers recommend a compression of 20 % to 25 % to provide the proper O-ring compression over the temperature range. Silicone or fluorosilicone O-rings are commonly used as they tend to take less of a set over temperature versus other O-ring materials. System operating temperatures and sealant media compatibility are the two most important parameters which must be considered when selecting an O-ring base polymer. See Figures 19 and 20, and Table 29 for more information.

Figure 19. Guidelines for O-ring Manifold Designs¹

NN Pressure Port

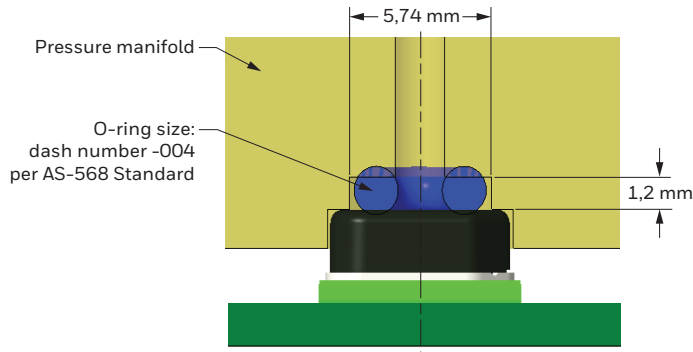

VN Pressure Port²

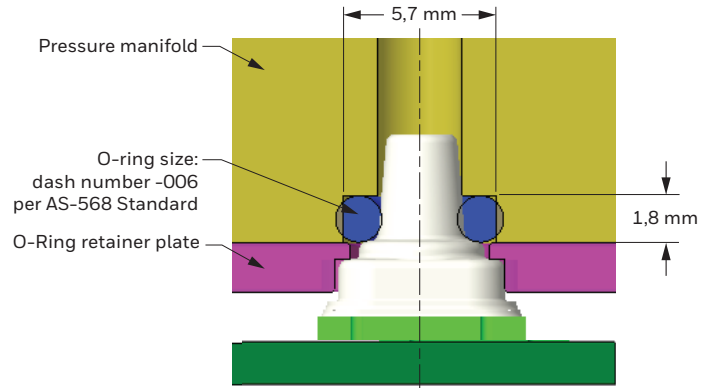

AN Pressure Port

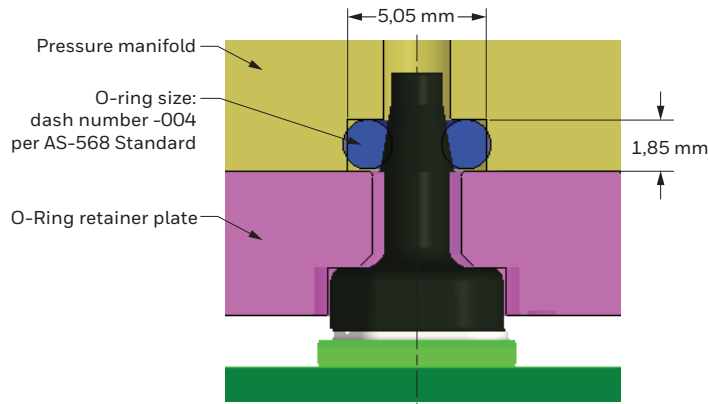

SN Pressure Port²

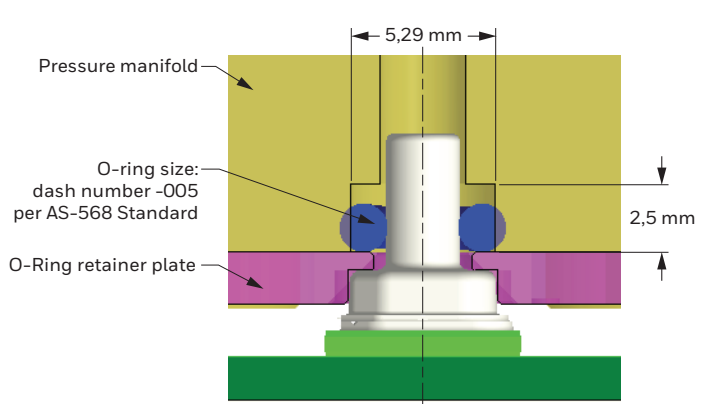

¹The recommended design has been validated for operating conditions ranging from -40°C to 110°C and up to 16 bar gage pressure.

²For more demanding applications, a second O-ring can be used with a gland height of 3,6 mm (VN pressure port) and 4,55 mm (SN pressure port).

Figure 20. Force vs. % of O-ring Compression for N Port Type

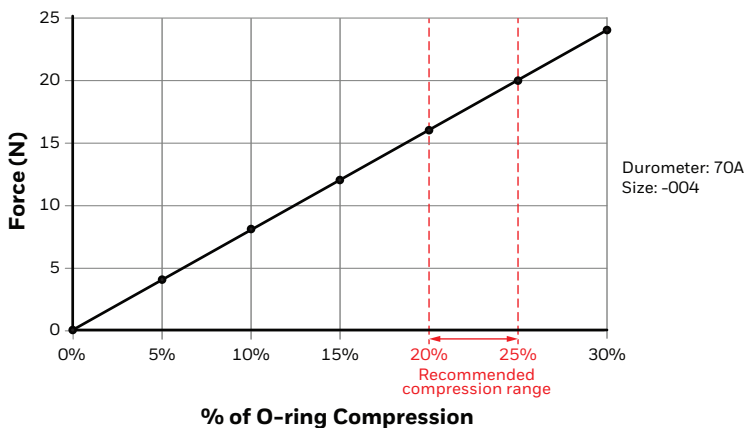

NOTICE

It is the buyer's sole responsibility to determine the suitability of the product in the application.

BASIC BOARD-MOUNT PRESSURE SENSORS ABP2 SERIES

TABLE 29. RECOMMENDED O-RINGS

Pressure Port	O-ring size AS-568 uniform dash numbers	O-ring ID (mm)	O-ring C/S (mm)	Material	Supplier	Part Number	Shore Hardness
NN	-004	1,78	1,78	Fluoroelastomer	McMaster	8333T114	Durometer 70A
NN	-004	1,78	1,78	Silicone	McMaster	1283N14	Durometer 70A
AN	-004	1,78	1,78	Fluoroelastomer	McMaster	8333T114	Durometer 70A
AN	-004	1,78	1,78	Silicone	McMaster	1283N14	Durometer 70A
SN	-005	2,57	1,78	Fluoroelastomer	McMaster	8333T115	Durometer 70A
SN	-005	2,57	1,78	Silicone	McMaster	1283N15	Durometer 70A
VN	-006	2,90	1,78	Fluoroelastomer	McMaster	8333T116	Durometer 70A
VN	-006	2,90	1,78	Silicone	McMaster	1283N16	Durometer 70A

⚠️ WARNING IMPROPER INSTALLATION

- Consult with local safety agencies and their requirements when designing a machine-control link, interface and all control elements that affect safety.
- Strictly adhere to all installation instructions.

Failure to comply with these instructions could result in death or serious injury.

⚠️ WARNING MISUSE OF DOCUMENTATION

- The information presented in this product sheet is for reference only. Do not use this document as a product installation guide.
- Complete installation, operation, and maintenance information is provided in the instructions supplied with each product.

Failure to comply with these instructions could result in death or serious injury.

WARRANTY/REMEDY

Honeywell warrants goods of its manufacture as being free of defective materials and faulty workmanship during the applicable warranty period. The Honeywell standard product warranty applies unless agreed to otherwise by Honeywell in writing; please refer to your order acknowledgment or consult your local sales office for specific warranty details. If warranted goods are returned to Honeywell during the period of coverage, Honeywell will repair or replace, at its option, without charge those items that Honeywell, in its sole discretion, finds defective. **The foregoing is buyer's sole remedy and is in lieu of all other warranties, expressed or implied, including those of merchantability and fitness for a particular purpose. In no event shall Honeywell be liable for consequential, special, or indirect damages.**

While Honeywell may provide information or engineering support for its products through Honeywell personnel, literature and website, it is the buyer's sole responsibility to determine the suitability of the Honeywell product(s) for the buyer's requirements

Specifications may change without notice. The information we supply is believed to be accurate as of this writing. However, Honeywell assumes no responsibility for its use.

For more information

Honeywell Sensing Solutions services its customers through a worldwide network of sales offices and distributors. For application assistance, current specifications, pricing, or the nearest Authorized Distributor, visit [automation.honeywell.com](https://www.automation.honeywell.com) or call:

USA/Canada	+302 613 4491
Latin America	+1 305 805 8188
Europe	+44 1344 238258
Japan	+81 (0) 3-6730-7152
Singapore	+65 6355 2828
Greater China	+86 4006396841

Honeywell Sensing Solutions

830 East Arapaho Road
Richardson, TX 75081
www.honeywell.com

Fre-Thane® is a registered trademark of Freelin-Wade Co.
Superthane® is a registered trademark of NewAge® Industries.

32350268-F-EN | F | 06/24
© 2024 Honeywell International Inc. All rights reserved.

Honeywell

Looking for pricing, stock, or lifecycle information?

Click below to explore more details on WIN SOURCE:

- ⊖ [View ABP2DRRT001PDAA3XX on WIN SOURCE](#)
- ⊖ [Honeywell Information](#)

Optimize Your Supply Chain with WIN SOURCE Solutions

- ✓ Global Sourcing Solution
- ✓ Obsolete Management
- ✓ Cost Control Management
- ✓ Shortage Management
- ✓ Alternative Solution
- ✓ Excess Inventory Management