

Click [here](#) for production status of specific part numbers.

MAX20096/MAX20097 Dual-Channel Synchronous Buck, High-Brightness LED Controller with and without SPI Interface

General Description

The MAX20096/MAX20097 are dual-channel, high-voltage, synchronous n-channel high-current buck LED drivers. The ICs use a proprietary average current-mode-control scheme to regulate the inductor current. This control method does not require any control-loop compensation, maintaining nearly constant switching frequency. Inductor current sense is achieved by sensing the current in the bottom switching device. The ICs integrate two fully synchronous buck-converter controllers, and operate over a wide 4.5V to 65V input range. The ICs are designed for high-frequency operation and can operate at switching frequencies as high as 1MHz.

In the MAX20096, the output voltages and currents on both channels and the junction temperature can be read back through the SPI interface. Protection features include inductor current-limit protection, overvoltage protection, and thermal shutdown. The MAX20096 is available in a space-saving thermally enhanced (5mm x 5mm), 32-pin side-wettable TQFN package and is specified to operate over the -40°C to +125°C automotive temperature range.

The MAX20097 is available in a 28-pin thermally enhanced TSSOP package, but does not have the SPI interface. It includes an open-drain fault flag (FLT_B) that goes low in case of an open string, shorted string, or overvoltage activation in any one of the channels, or also in thermal shutdown.

Applications

- Automotive Exterior Lighting
 - High-Beam/Low-Beam/Signal/Position Lights
 - Daytime Running Lights (DRLs)
 - Fog Light and Adaptive Front Light Assemblies
- Commercial, Industrial, and Architectural Lighting

Benefits and Features

- Integration Minimizes BOM for High-Brightness LED Driver, Saving Space and Cost
 - Wide 4.5V to 65V Input Voltage Range
 - No Compensation Components
 - Programmable Switching Frequency
 - External MOSFETs that are Sizable for the Appropriate Current
- Wide Dimming Ratio Allows High-Contrast Ratio
 - Analog Dimming
 - PWM Dimming
- Suitable for Matrix Lighting
 - Maintains Current Regulation While Shorting/Opening Individual LEDs in the String
 - Ultra-Fast Response Control Loop Prevents Overshoots and Undershoots
- Protection Features and Wide Temperature Range Increase System Reliability
 - Short Circuit, Overvoltage, and Thermal Protection
 - -40°C to +125°C Operating Temperature Range
 - Thermal Monitor and LED Current Monitor
- Fault Diagnosis Through SPI Interface and Through FLT_B Pin for Applications without SPI Interface

Ordering Information appears at end of data sheet.

Absolute Maximum Ratings

V_{IN} to V_{AGND}	-0.3V to +70V	Short-Circuit Current on V_{CC}	Continuous
$V_{LX_}$ to V_{AGND}	-0.3V to ($V_{IN} + 0.3$)V	Continuous Power Dissipation (Multilayer Board)	
$V_{CSN_}$, $V_{CSP_}$ to V_{AGND}	-2.5V to +6V	32-Pin SW TQFN ($T_A = +70^\circ\text{C}$, derate 34.5mW/ $^\circ\text{C}$	
V_{CC} , V_{IO} to V_{AGND}	-0.3V to +6.0V	above +70 $^\circ\text{C}$)	2758.6mW
$V_{BST_}$ to V_{AGND}	-0.3V to +72.0V	Continuous Power Dissipation (Multilayer Board)	
$V_{BST_}$ to $V_{LX_}$	-0.3V to +6.0V	28-Pin TSSOP ($T_A = +70^\circ\text{C}$, derate 29.7mW/ $^\circ\text{C}$	
$V_{TON_}$ to V_{AGND}	-0.3V to +65V	above +70 $^\circ\text{C}$)	mW to 2380mW
V_{PGND} to V_{AGND}	-0.3V to +0.3V	Operating Temperature Range.....	-40 $^\circ\text{C}$ to +125 $^\circ\text{C}$
$V_{REF1_}$ to V_{AGND}	-0.3V to +2.5V	Junction Temperature.....	+150 $^\circ\text{C}$
$V_{DIM_}$ to V_{AGND}	-0.3V to +6.0V	Storage Temperature Range.....	-40 $^\circ\text{C}$ to +150 $^\circ\text{C}$
$V_{OUT_}$, V_{CSB} , V_{SCLK} , V_{SDI} , V_{RESETB} to V_{AGND}		Soldering Temperature (reflow).....	+260 $^\circ\text{C}$
-0.3V to +6.0V, V_{SDO} to V_{AGND}	-0.3V to ($V_{IO} + 0.3$)V		

Stresses beyond those listed under "Absolute Maximum Ratings" may cause permanent damage to the device. These are stress ratings only, and functional operation of the device at these or any other conditions beyond those indicated in the operational sections of the specifications is not implied. Exposure to absolute maximum rating conditions for extended periods may affect device reliability.

Package Thermal Characteristics (Note 1)

32-Pin SW TQFN		28-Pin TSSOP	
Thermal Resistance, Single-Layer Board:		Thermal Resistance, Single-Layer Board:	
Junction-to-Ambient Thermal Resistance (θ_{JA})	47 $^\circ\text{C}/\text{W}$	Junction-to-Ambient Thermal Resistance (θ_{JA})	45 $^\circ\text{C}/\text{W}$
Junction-to-Case Thermal Resistance (θ_{JC}).....	3 $^\circ\text{C}/\text{W}$	Junction-to-Case Thermal Resistance (θ_{JC}).....	2 $^\circ\text{C}/\text{W}$
Thermal Resistance, Four-Layer Board:		Thermal Resistance, Four-Layer Board:	
Junction-to-Ambient Thermal Resistance (θ_{JA})	36 $^\circ\text{C}/\text{W}$	Junction-to-Ambient Thermal Resistance (θ_{JA})	33.6 $^\circ\text{C}/\text{W}$
Junction-to-Case Thermal Resistance (θ_{JC}).....	3 $^\circ\text{C}/\text{W}$	Junction-to-Case Thermal Resistance (θ_{JC}).....	3.3 $^\circ\text{C}/\text{W}$

Note 1: Package thermal resistances were obtained using the method described in JEDEC specification JESD51-7, using a four-layer board. For detailed information on package thermal considerations, refer to www.maximintegrated.com/thermal-tutorial.

For the latest package outline information and land patterns (footprints), go to www.maximintegrated.com/packages. Note that a "+", "#", or "-" in the package code indicates RoHS status only. Package drawings may show a different suffix character, but the drawing pertains to the package regardless of RoHS status.

Electrical Characteristics

($V_{IN} = 12\text{V}$, Limits are 100% tested at $T_A = +25^\circ\text{C}$ and $T_A = +125^\circ\text{C}$. Limits over the operating temperature range and relevant supply voltage range are guaranteed by design and characterization. Specifications marked "GBD" are guaranteed by design and not production tested.)

PARAMETER	SYMBOL	CONDITIONS	MIN	TYP	MAX	UNITS
INPUT SUPPLY VOLTAGE						
Operational Supply Voltage	V_{IN}		4.5		65	V
IN Supply Current	I_{INQ}	DIM1 = DIM2 = 5V			10	mA
V_{CC} REGULATOR						
Output Voltage	V_{CC}	$I_{VCC} = 1\text{mA}$, $5.5\text{V} < V_{IN} < 65\text{V}$	4.875	5.0	5.125	V
		$I_{VCC} = 10\text{mA}$, $6\text{V} < V_{IN} < 25\text{V}$	4.875	5.0	5.125	
V_{CC} Dropout Voltage		$I_{VCC} = 10\text{mA}$, $V_{IN1} = 4.5\text{V}$		200	500	mV
V_{CC} Short-Circuit Current	V_{CCIMAX}	$V_{CC} = 0\text{V}$		60		mA
V_{CC} Undervoltage Lockout, Rising	$V_{CCUVLOR}$	I_{NS} rising	3.8	4.1	4.4	V
V_{CC} Undervoltage Lockout, Falling	$V_{CCUVLOF}$	I_{NS} falling	3.55	3.85	4.15	V

Electrical Characteristics (continued)

($V_{IN} = 12V$, Limits are 100% tested at $T_A = +25^\circ C$ and $T_A = +125^\circ C$. Limits over the operating temperature range and relevant supply voltage range are guaranteed by design and characterization. Specifications marked "GBD" are guaranteed by design and not production tested.)

PARAMETER	SYMBOL	CONDITIONS	MIN	TYP	MAX	UNITS
ANALOG DIMMING INPUT						
REFI Input Voltage Range (Fail-Safe Mode)	REFI _{RNG}	RESETB = 0 or RESETB = 1 with CNFG_SEL = 0	0.2		1.2	V
REFI Zero-Current Threshold, Falling (Fail-Safe Mode)	REFI _{ZC_TH}	RESETB = 0 or RESETB = 1 with CNFG_SEL = 0, CS < 5mV	0.165	0.18	0.195	V
Zero-Current Threshold, Falling (SPI Enabled)				0.176		A
REFI Clamp Voltage	REFI _{CLMP}	RESETB = 0 or RESETB = 1 with CNFG_SEL = 0, IREFI sink = 1 μ A	1.274	1.3	1.326	V
REFI Input Bias Current	REFI _{IN}	RESETB = 0 or RESETB = 1 with CNFG_SEL = 0	0	20	200	nA
ON-TIME CONTROL/OVERVOLTAGE PROTECTION/SHORT FAULT INDICATOR						
Minimum On-Time	t _{ON-MIN}			60	100	ns
Programmed On-Time	t _{ON}	V _{OUT} = 1V, C1 = C4 = 1nF, R1 = R4 = 24.9k Ω , V _{IN} = 12V		2.27		μ s
TON_ Pulldown Resistance				15	40	Ω
OUT_ Overvoltage Threshold	V _{TH_OVP_}	OUT rising, RESETB = 0 or RESETB = 1 and SPI_EN = 0	2.45	2.5	2.55	V
OUT_ Overvoltage Hysteresis		OUT_ falling		22		mV
Short Fault Threshold		Output failing, V _{OUT_} is lower than threshold, no SPI		50		mV
		SPI enabled, V_SHORT_[1:0] = b'00, V _{OUT_} is lower than threshold		100		
		SPI enabled, V_SHORT_[1:0] = 11, V _{OUT_} is lower than threshold		400		
OFF-TIME CONTROL						
Minimum Off-Time		V _{CS_} = 0V		160	280	ns
Linear Range of Pulse Doubler			0.25		2.5	μ s
Maximum Off-Time				42		μ s
PWM DIMMING (FAIL-SAFE MODE)						
Internal Ramp Frequency	f _{RAMP}		180	200	220	Hz
Phase Shift Between DIM1 and DIM2	P _{SFT}	Fail-safe mode using internal 200Hz dimming		180		deg
External Sync Frequency Range			80		2000	Hz
External Sync Low-Level Voltage	V _{LTH}		0.4			V
External Sync High-Level Voltage	V _{HTH}				3.2	V

Electrical Characteristics (continued)

($V_{IN} = 12V$, Limits are 100% tested at $T_A = +25^\circ C$ and $T_A = +125^\circ C$. Limits over the operating temperature range and relevant supply voltage range are guaranteed by design and characterization. Specifications marked "GBD" are guaranteed by design and not production tested.)

PARAMETER	SYMBOL	CONDITIONS	MIN	TYP	MAX	UNITS
DIM Comparator Offset Voltage			170	200	230	mV
DIM Voltage for 100% Duty Cycle			3.2			V
PWM DIMMING (SPI CONTROLLED)						
Programmed Dimming Frequency		SPI enabled with PWM1_SEL = PWM2_SEL = 1, PWM_FREQ[2:0] = 0		200		Hz
		SPI enabled with PWM1_SEL = PWM2_SEL = 1, PWM_FREQ[2:0] = 110		2000		
		SPI enabled with PWM1_SEL = PWM2_SEL = 1, PWM_FREQ[2:0] = 001		333		
Programmed DIM Duty Cycle		SPI is enabled, PWM1_SEL = PWM2_SEL = 1, PWM_DUTY[9:0] = 1LSB		0.1		%
		SPI is enabled, PWM1_SEL = PWM2_SEL = 1, PWM_DUTY[9:0] = 500		50		
		SPI is enabled, PWM1_SEL = PWM2_SEL = 1, PWM_DUTY[9:0] = 1000		100		
CURRENT-SENSE AMPLIFIER						
Current-Sense Amplifier Offset			0.192	0.2	0.208	V
Current-Sense Gain			4.84	5.0	5.12	V/V
CURRENT MONITOR						
Offset Voltage				0.2		V
Current Monitor Amplifier Gain				5		V/V
DH_ AND DL_ DRIVERS						
DH_ Sourcing Resistance	R_{ON_HS}	$D_H = \text{high}$, $T_A = -40^\circ C$ to $+125^\circ C$		2.5	5.0	Ω
DH_ Sinking Resistance	R_{DH_SINK}	$D_H = \text{low}$, $T_A = -40^\circ C$ to $125^\circ C$		1.0	2.0	Ω
DL_ Sourcing Resistance	R_{DL_SRC}	$D_L = \text{high}$, $T_A = -40^\circ C$ to $+125^\circ C$		2.5	5.0	Ω
DL_ Sinking Resistance	R_{DL_SINK}	$D_L = \text{low}$, $T_A = -40^\circ C$ to $+125^\circ C$		1.8	3.5	Ω
DH_-to-DL_ Dead Time		DH_ fall to DL_ rise, CL = 1nF (measured at $V_{TH} = 1.5V$)		20		ns
DL_-to-DH_ Dead Time		DL_ fall to DH_ rise, CL = 1nF (measured at $V_{TH} = 1.5V$)		20		ns
ADC (MAX20096 ONLY)						
Resolution				8		bits
Offset Error			-2		+2	%FS
Gain Error			-2		+2	%FS
SPI ELECTRICAL CHARACTERISTICS (MAX20096 ONLY)						
I/O Supply Voltage	V_{IO}		1.8		5.5	V
Static I/O Supply Current (Note 2)	I_{DDIO}	Static inputs, all outputs unloaded			1	μA

Electrical Characteristics (continued)

($V_{IN} = 12V$, Limits are 100% tested at $T_A = +25^\circ C$ and $T_A = +125^\circ C$. Limits over the operating temperature range and relevant supply voltage range are guaranteed by design and characterization. Specifications marked "GBD" are guaranteed by design and not production tested.)

PARAMETER	SYMBOL	CONDITIONS	MIN	TYP	MAX	UNITS
DIGITAL INPUT CHARACTERISTICS (SCLK, SDI, CSB, RESETB)						
Input High-Voltage V_{MAX}	V_{IH}	$2.2V < V_{IO} < 5.5V$	$0.7 \times V_{IO}$			V
Input High-Voltage V_{MIN}	V_{IH}	$1.8V < V_{IO} < 2.2V$	$0.8 \times V_{IO}$			V
Input Low-Voltage V_{MAX}	V_{IL}	$2.2V < V_{IO} < 5.5V$			$0.3 \times V_{IO}$	V
Input Low-Voltage V_{MIN}	V_{IL}	$1.8V < V_{IO} < 2.2V$			$0.2 \times V_{IO}$	V
Input Leakage Current (Note 3)	I_{IN}	$V_{IN} = 0V$ or V_{IO}		± 0.1	± 1	μA
Internal Safety-Impedance Pulldown (Notes 4, 5)	R_{PD}	SDI, SCLK pulldown to AGND	40	100	160	k Ω
Internal Safety-Impedance Pullup (Notes 4, 5)	R_{PU}	CSB, RESETB pullup to V_{IO}	40	100	160	k Ω
Input Capacitance	C_{IN}			10		pF
Hysteresis Voltage	V_H			0.35		V
DIGITAL OUTPUT CHARACTERISTICS (SDO)						
Output High-Voltage V_{MAX}	V_{OH}	$V_{IO} > 2.5V$, $I_{SOURCE} = 5mA$	$V_{IO} - 0.4$			V
Output High-Voltage V_{MIN}	V_{OH}	$V_{IO} > 1.8V$, $I_{SOURCE} = 2mA$	$V_{IO} - 0.4$			V
Output Low-Voltage V_{MAX}	V_{OL}	$V_{IO} > 2.5V$, $I_{SINK} = 5mA$			0.4	V
Output Low-Voltage V_{MIN}	V_{OL}	$V_{IO} > 1.8V$, $I_{SINK} = 2mA$			0.4	V
Output Short-Circuit Current	I_{OSS}	I_{SINK} , I_{SOURCE}		250		mA
Output Three-State Leakage	I_{OZ}			± 0.1	± 1	μA
Output Three-State Capacitance	C_{OZ}			10		pF
SPI TIMING CHARACTERISTICS (MAX20096 ONLY)						
SCLK Frequency	f_{SCLK}		0		4	MHz
SCLK Period	t_{CP}		250			ns
SCLK Pulse Width High	t_{CH}			62.5		ns
SCLK Pulse Width Low	t_{CL}	(Note 6)		62.5		ns
CSB Fall to SCLK Rise Setup Time	t_{CSS0}	To 1st SCLK rising edge (RE) (Note 6)	25			ns
CSB Fall to SCLK Rise Hold Time	t_{CSH0}	Applies to inactive rising edge preceding 1st rising edge	25			ns
CSB Rise to SCLK Rise Hold Time	t_{CSH1}	Applies to N x 16th rising edge	25			ns

Electrical Characteristics (continued)

($V_{IN} = 12V$, Limits are 100% tested at $T_A = +25^\circ C$ and $T_A = +125^\circ C$. Limits over the operating temperature range and relevant supply voltage range are guaranteed by design and characterization. Specifications marked "GBD" are guaranteed by design and not production tested.)

PARAMETER	SYMBOL	CONDITIONS	MIN	TYP	MAX	UNITS
CSB Rise to SCLK Rise	t_{CSA}	Applies to N x 16th rising edge, guarantees aborted (unqualified) sequence	25			ns
CSB Rise to SCLK Rise	t_{CSQ}	Applies to (N x 16) + 1 rising edge, guarantees qualified sequence	25			ns
CSB Pulse Width High	t_{CSPW}		100			ns
SDI-to-SCLK Rise Setup Time	t_{DS}		20			ns
SDI-to-SCLK Rise Hold Time	t_{DH}		20			ns
RESETB Pulse Width Low	t_{RBPW}	For request to be recognized	25			ns
RESETB Rise to CSB Fall Removal	t_{RBCS}	For write transaction to be executed	20			ns
SCLK Fall to SDO Transition	t_{DOT}	$C_{LOAD} = 20pF$			100	ns
SCLK Fall to SDO Hold	t_{DOH}	$C_{LOAD} = 0pF$	2			ns
CSB Fall to SDO Transition	t_{DOE}	$C_{LOAD} = 20pF$			100	ns
CSB Rise to SDO Hi-Z	t_{DOZ}	Output disable time			80	ns
THERMAL SHUTDOWN						
Thermal Warning (MAX20096 only)				150		$^\circ C$
Thermal Shutdown				165		$^\circ C$
Hysteresis				15		$^\circ C$

Note 2: Static logic inputs with $V_{IL} = AGND$ and $V_{IH} = V_{IO}$. CSB, RESETB = V_{IH} (if safety pullup active).

Note 3: No internal safety pullup/pulldown impedances active, input buffers only.

Note 4: Internal safety pullup/pulldown impedances available, with enable function.

Note 5: If pullup is supported, note CSB and RESETB connection and diode to V_{IO} ; this diode is present regardless of enable mode.

Note 6: Applications must afford time for the device to drive data on the SDO bus and meet the μC setup time prior to the μC latching in the result on the following SCLK rising edge. In practice, this is determined by loading and μC characteristics, and the relevant t_{DOT}/t_{DOE} specification must be satisfied.

Typical Operating Characteristics

($T_A = +25^\circ\text{C}$, unless otherwise noted.)

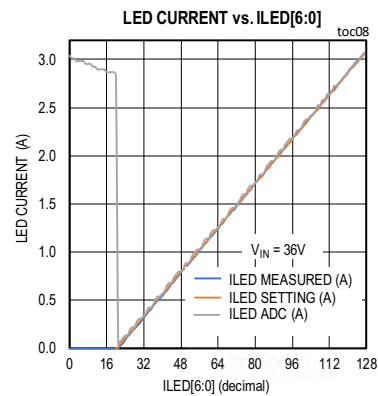
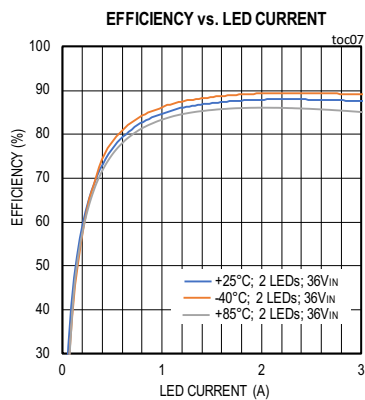
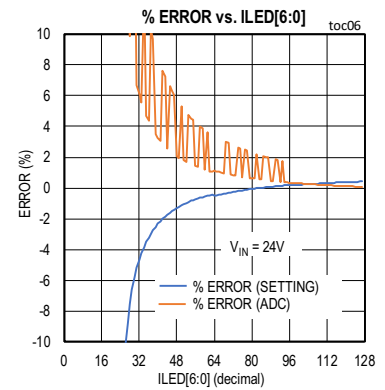
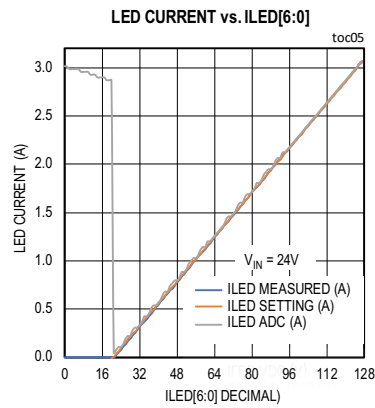
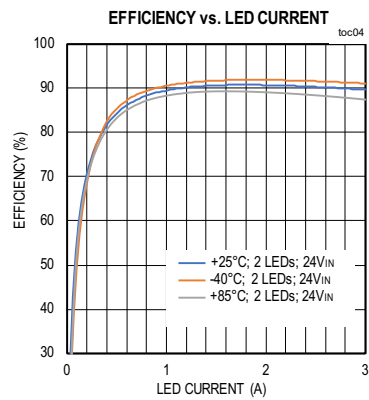
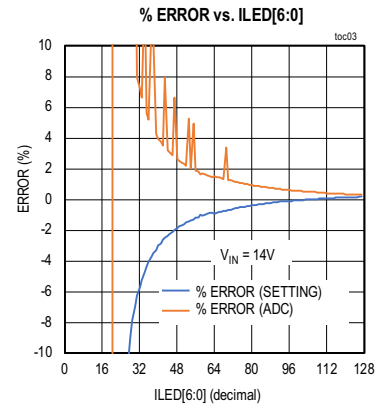
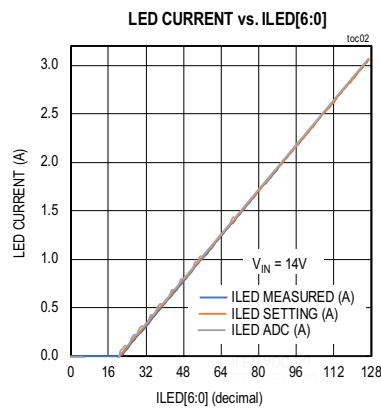
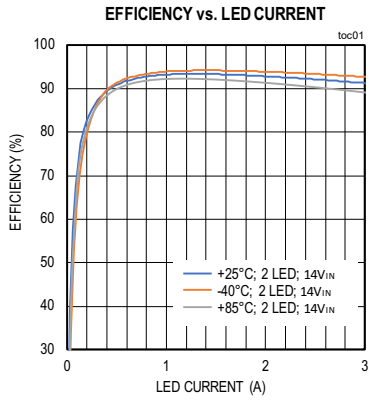

Typical Operating Characteristics (continued)

(T_A = +25°C, unless otherwise noted.)

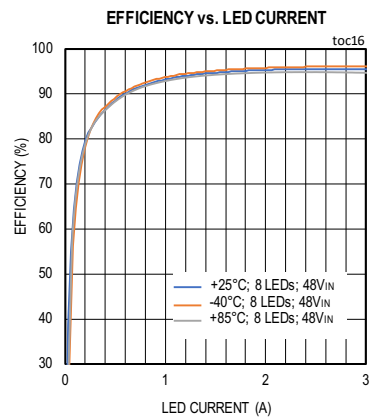
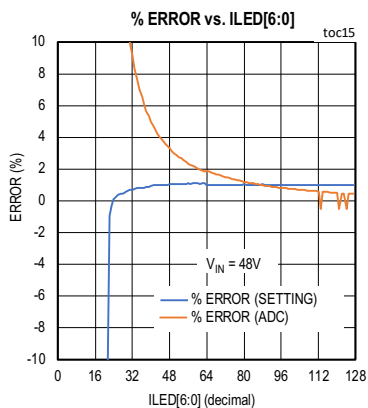
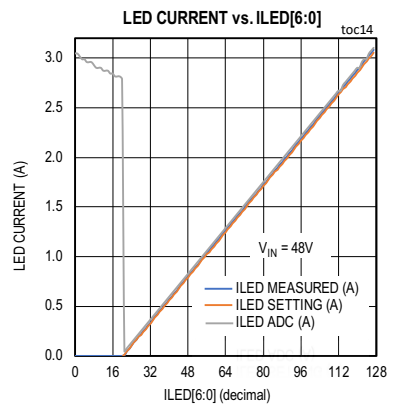
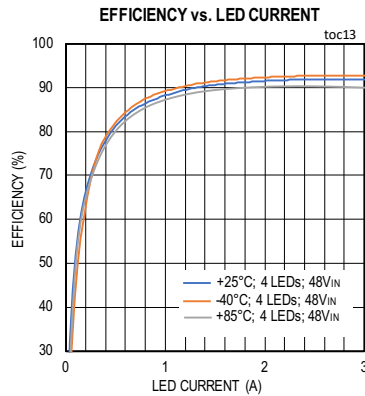
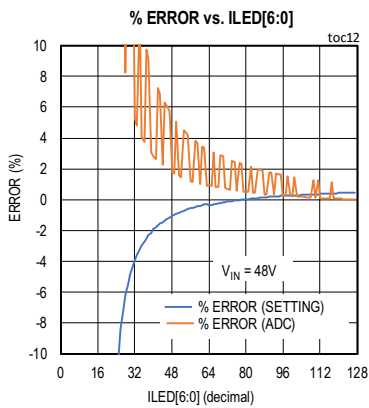
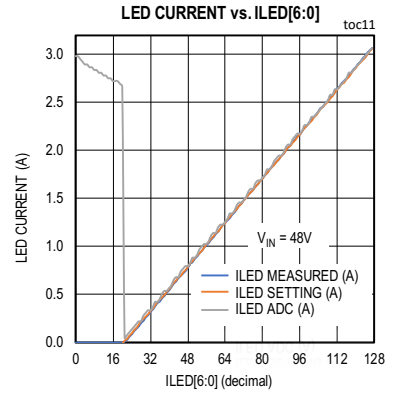
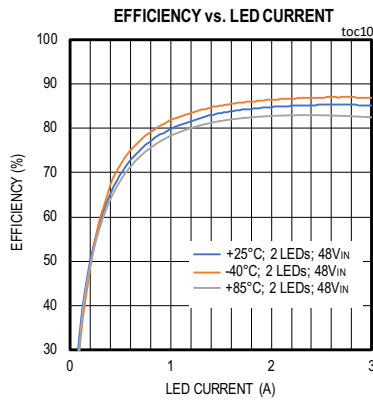
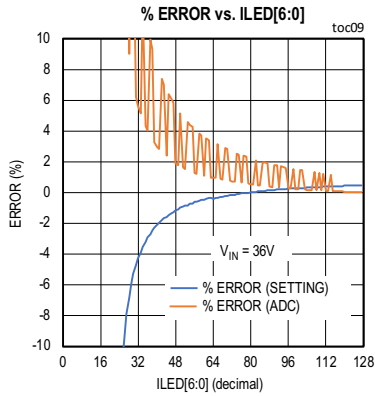

Typical Operating Characteristics (continued)

($T_A = +25^\circ\text{C}$, unless otherwise noted.)

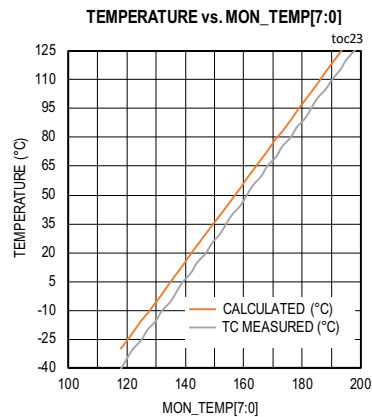
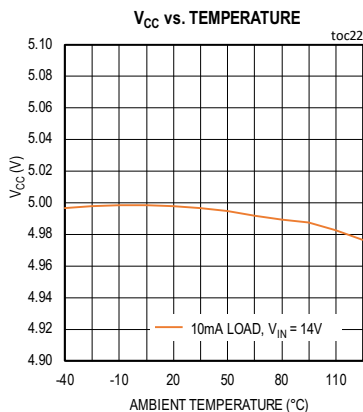
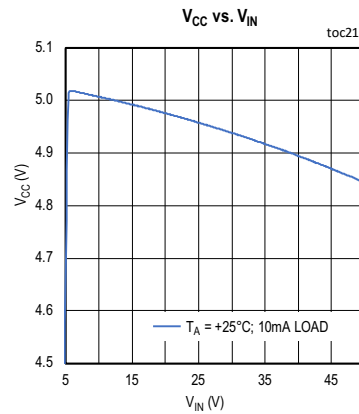
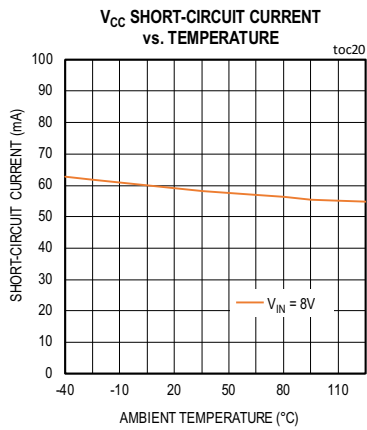
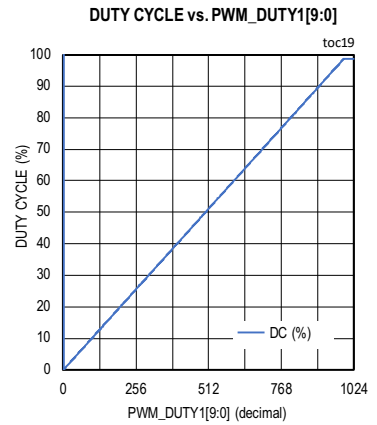
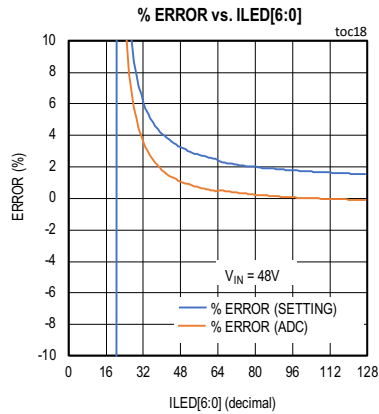
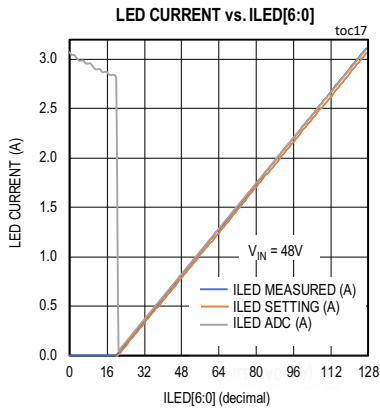

Pin Description

PIN		NAME	FUNCTION
SW TQFN MAX20096	TSSOP MAX20097		
1	4	LX1	Switching Node of Buck LED Driver on Channel 1. Connect to one end of output inductor on channel 1.
2	5	BST1	High-Side Power Supply for High-Side Gate Drive for Channel 1. Connect a 0.1 μ F ceramic capacitor from BST1 to LX1.
3	6	DH1	High-Side Driver of Channel 1. Connect to gate of high-side n-channel MOSFET of buck LED driver for channel 1. Use a series resistor to limit current slew rate and mitigate EMI noise, if required.
4	7	IN	Supply Input Pin for V_{CC} Regulator. Connect a 1 μ F ceramic capacitor from IN to PGND. If an external V_{CC} regulator is used, then connect IN to V_{CC} .
5	8	PGND	Power-Ground Connection
6	9	DH2	High-Side Driver of Channel 2. Connect to gate of high-side n-channel MOSFET of buck LED driver for channel 2. Use a series resistor to limit current slew rate and mitigate EMI noise, if required.
7	10	BST2	High-Side Power Supply for High-Side Gate Drive for Channel 2. Connect a 0.1 μ F ceramic capacitor from BST2 to LX2.
8	11	LX2	Switching Node of Buck LED Driver on Channel 2. Connect to one end of output inductor on channel 2.
9	12	DL2	Low-Side Driver of Channel 2. Connect to gate of low-side n-channel MOSFET of LED driver for channel 2. Use a series resistor to limit current slew rate and mitigate EMI noise, if necessary.
10	13	TON2	Frequency-Setting Pin for Channel 2. Connect a resistor to the input supply and capacitor to AGND to set switching frequency for channel 2.
11	14	OUT2	Connect a resistor-divider from OUT2 to the output voltage on channel 2. OUT2 has the scaled-down feedback of the output voltage on channel 2.
12	15	CSP2	Current-Sense Input on Channel 2. Connect to source of external MOSFET driven by DL2. Connect a resistor from this pin to CSN2 to sense the current in the MOSFET.
13	16	CSN2	Negative Current-Sense Connection on Channel 2. Connect this pin to power ground.
14	17	REFI2	Analog Dimming Input for Channel 2 in Default Mode. Connect to a resistor-divider from V_{CC} to set the default LED current in channel 2.
15	18	IOUV2	Current Monitor Output on Channel 2
16	19	DIM2	PWM Dimming Input in Default Mode for Channel 2. Connect to an external PWM signal or connect to an analog voltage between 0.2V and 3V to set the PWM duty cycle in channel 2.
17	—	CSB	Chip-Select Pin for SPI Interface. This pin is pulled low to enable the SPI Interface.
18	—	SCLK	Clock Input Pin for SPI Interface
19	—	SDI	Data Input Pin for SPI Interface
20	20	V_{CC}	+5V Regulator Output. Connect a 1 μ F ceramic capacitor from this pin to GND. If an internal V_{CC} regulator is not used, then connect V_{CC} to IN and connect an external V_{CC} to this pin.

Pin Description (continued)

PIN		NAME	FUNCTION
SW-TQFN MAX20096	TSSOP MAX20097		
21	21	AGND	Analog Ground Connection
22	22	V _{IO}	Microcontroller Power Supply Pin for MAX20096. For the MAX20097, connect V _{IO} to V _{CC} externally
23	—	SDO	Data Output Pin for SPI Interface externally
24	—	RESETB	Active-Low Reset Pin for SPI. Toggling the reset pin switches control switches programming of REF1_, DIM_, and oscillator frequency on both channels to the analog control pins.
25	24	DIM1	PWM Dimming Input in Default Mode for Channel 1. Connect to an external PWM signal or connect it to an analog voltage between 0.2V to 3V to set the PWM duty cycle in Channel 1.
26	25	IOUV1	Current Monitor Output on Channel 1
27	26	REF1	Analog Dimming Input for Channel 1 in Default Mode. Connect to a resistor divider from V _{CC} to set the default LED Current in Channel 1.
28	27	CSN1	Negative Current-Sense Connection on Channel 1. Connect CSN1 to power ground.
29	28	CSP1	Current-Sense Input on Channel 1. Connect to source of external MOSFET that is driven by DL1. Connect a resistor from this pin to CSN1 to sense the current in the MOSFET.
30	1	OUT1	Connect a resistor divider from this pin to the output voltage on channel 1. This pin has the scaled down feedback of the output voltage on channel 1.
31	2	TON1	Frequency-Setting Pin for Channel 1. Connect a resistor to the input supply and capacitor to AGND to set switching frequency for channel 1.
32	3	DL1	Low-Side Driver of Channel 1. Connect to gate of low-side N-channel MOSFET of LED Driver for channel 1. Use series resistor to limit current slew-rate and mitigate EMI noise if necessary.
—	23	FLT B	Fault Flag Output in MAX20097
—	—	EP	Exposed Pad. Connect EP to a large-area contiguous copper ground plane for effective power dissipation. Do not use as the main IC ground connection. EP must be connected to GND.

Buck Diagrams

MAX20096

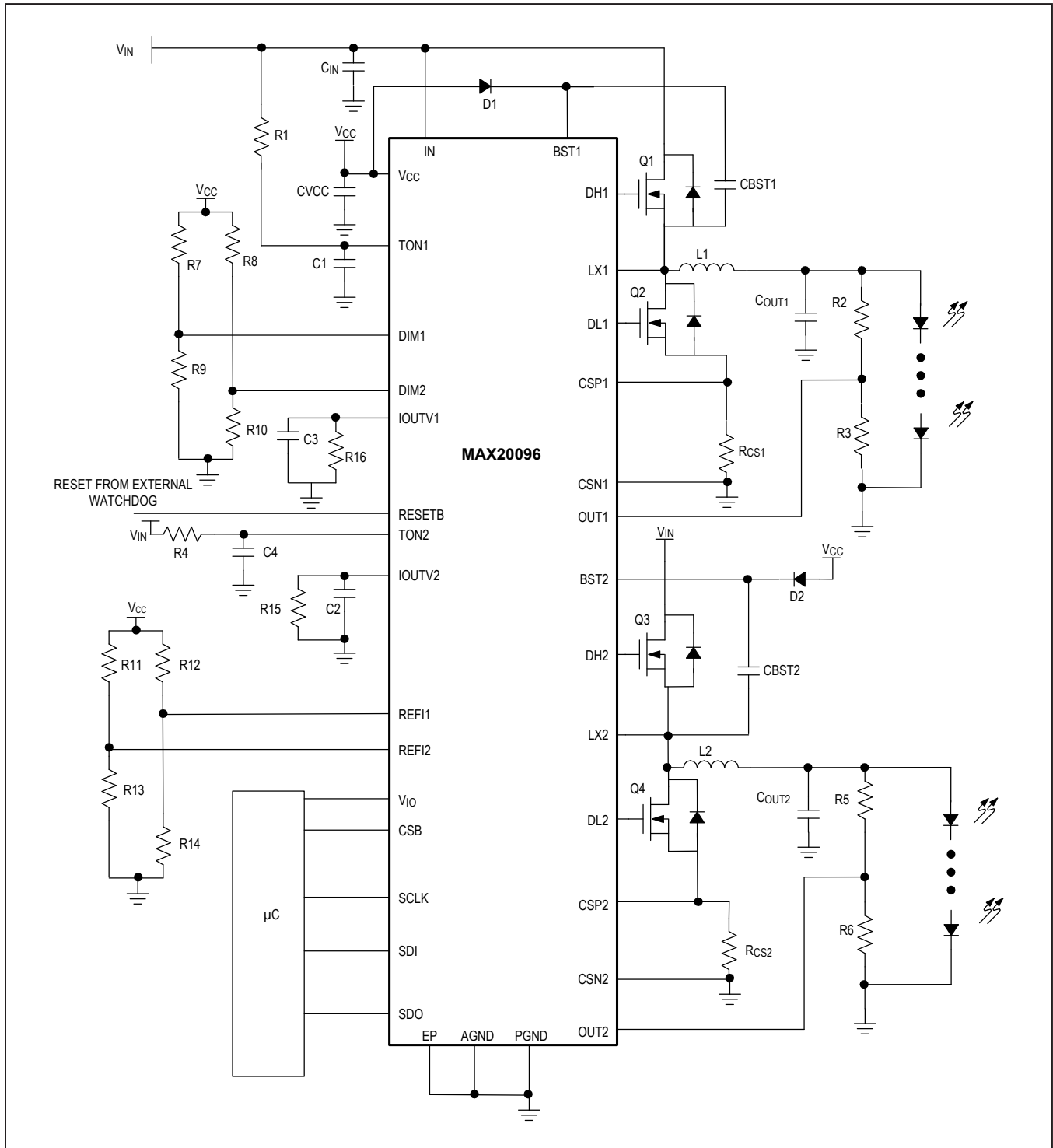

Buck Diagrams (continued)

MAX20097

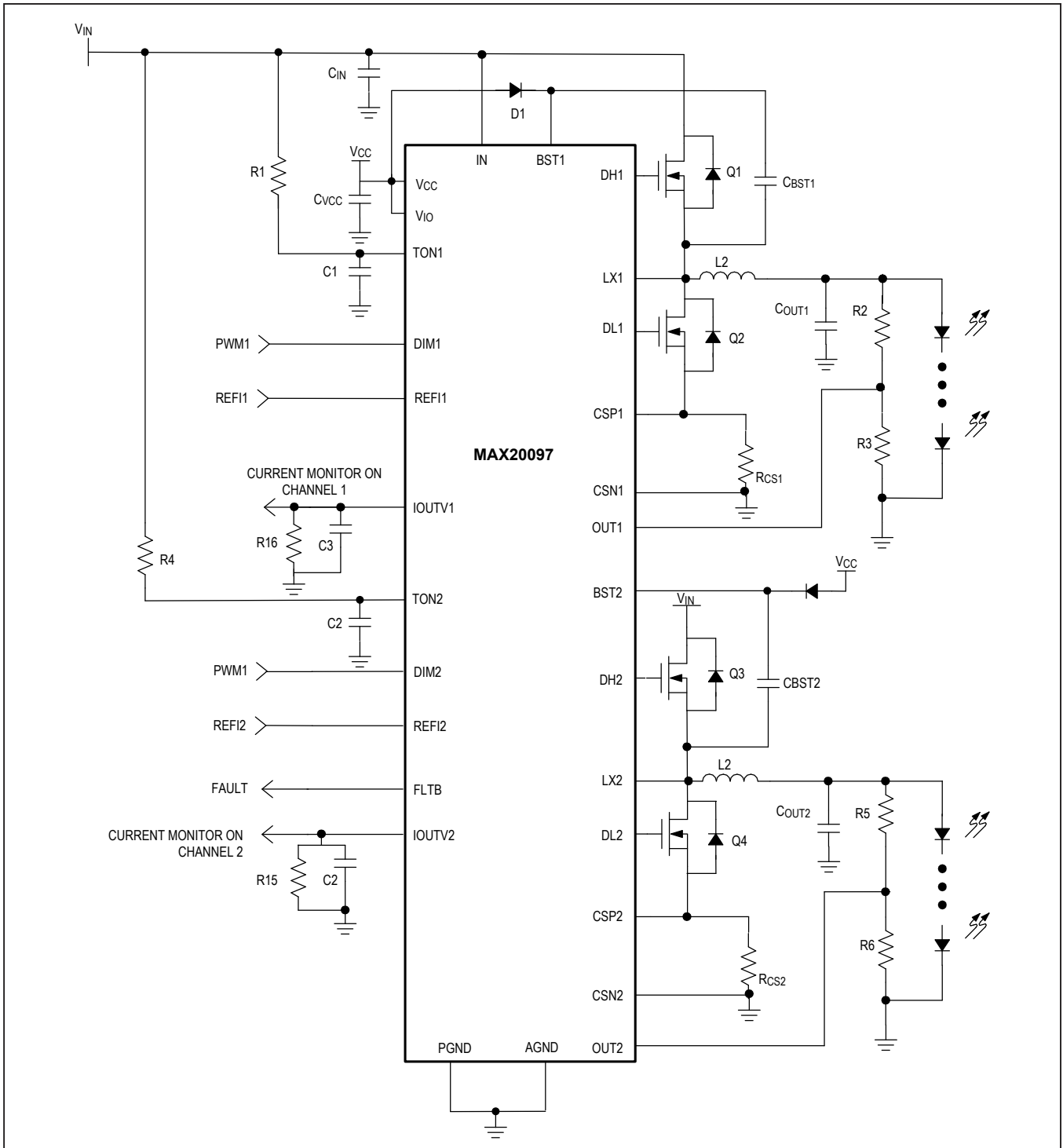

Block Diagrams

MAX20096

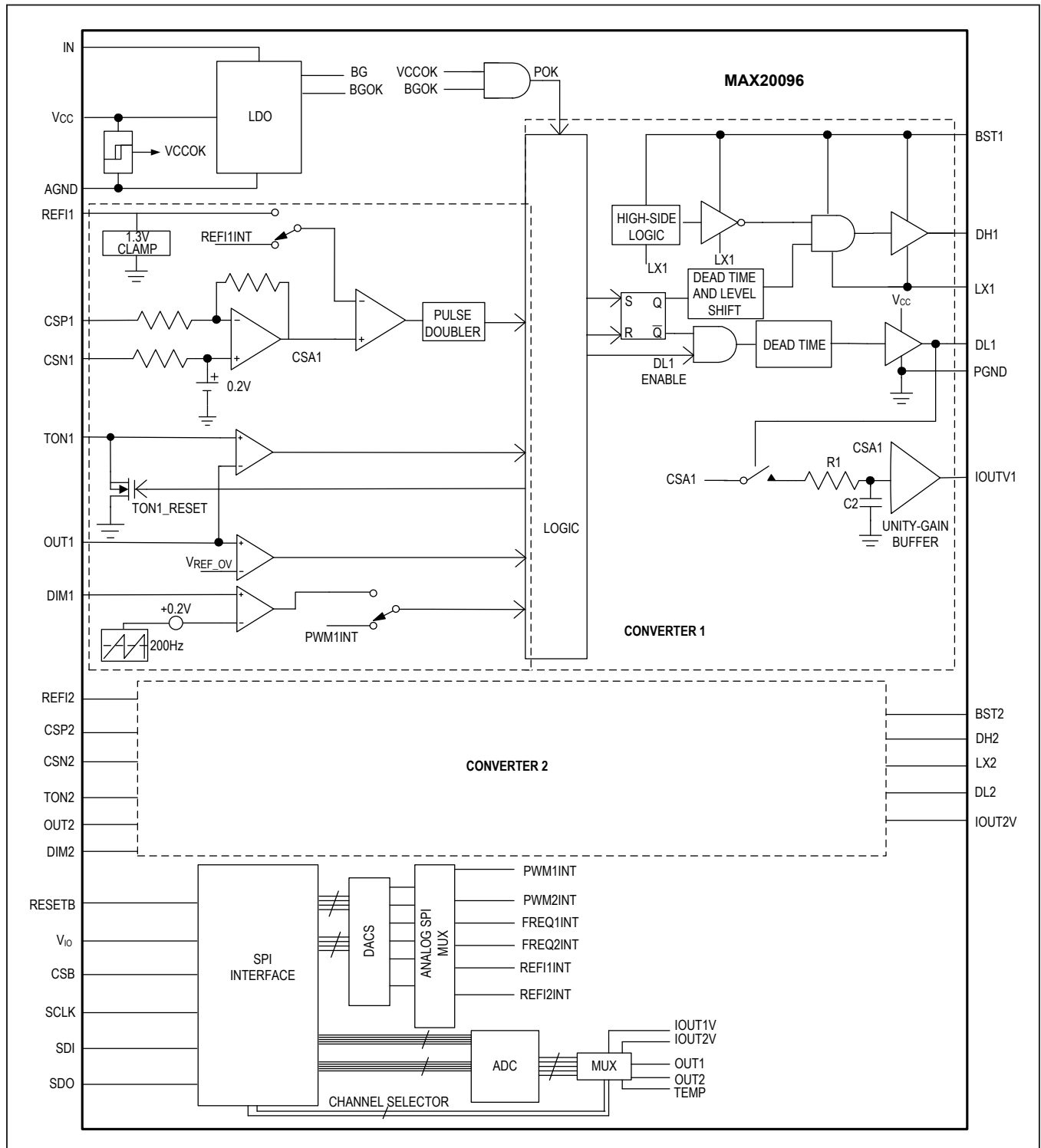

Block Diagrams (continued)

MAX20097

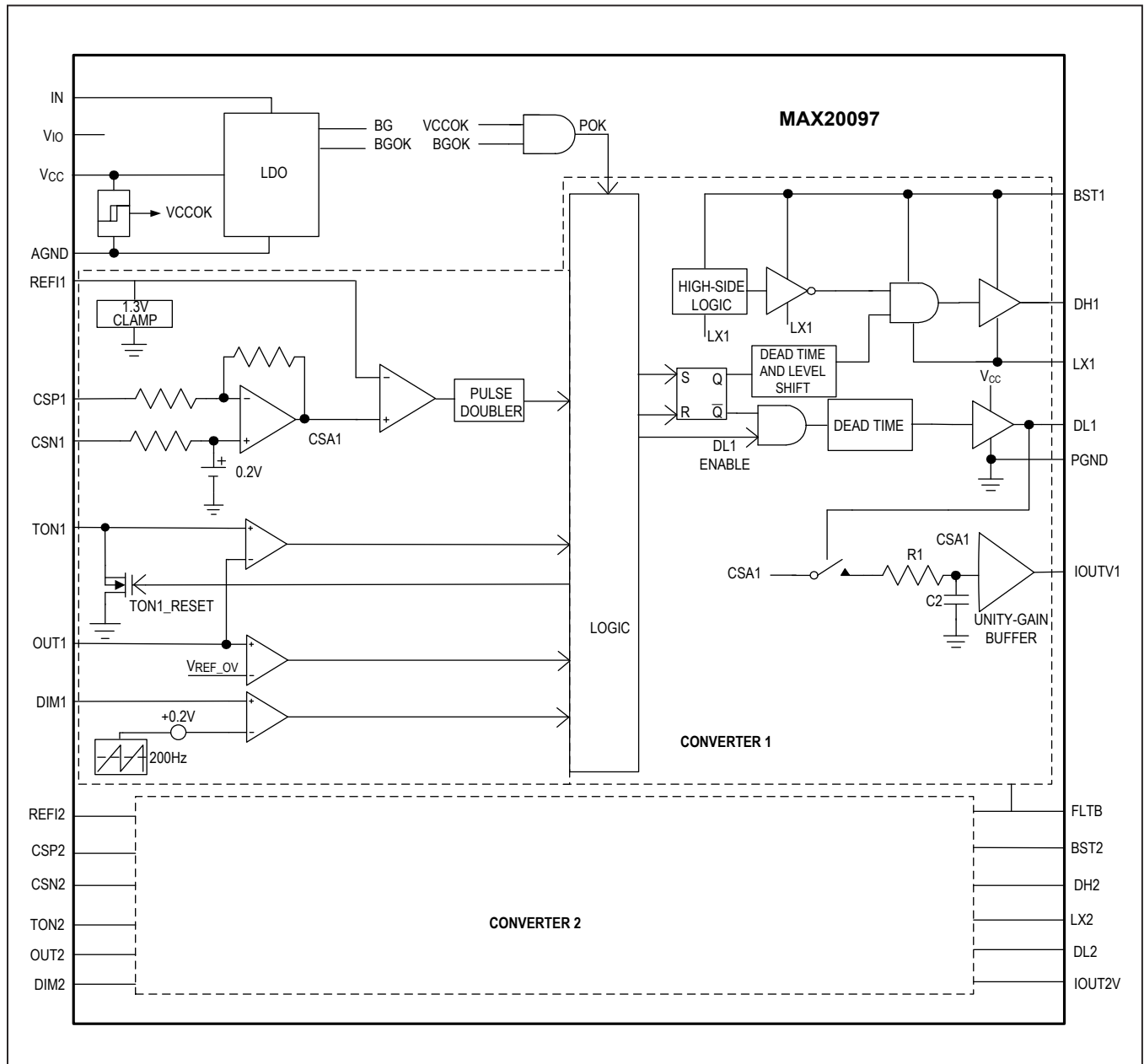

Detailed Description

The MAX20096/MAX20097 ICs are dual-channel, high-voltage, synchronous n-channel high-current buck LED drivers. The ICs use a proprietary average current-mode-control scheme to regulate the inductor current. This control method does not require any control-loop compensation, maintaining nearly constant switching frequency. Inductor current sense is achieved by sensing the current in the bottom switching device. The ICs integrate two fully synchronous buck controllers. The ICs operate over a wide 4.5V to 65V input range, are designed for high-frequency operation, and can operate at switching frequencies as high as 1MHz.

In the MAX20096, the output voltages and currents are on both channels and the junction temperature can be read back through the SPI interface. Protection features include inductor current-limit protection, overvoltage protection and thermal shutdown. The MAX20096 is available in a space-saving, thermally enhanced (5mm x 5mm), 32-pin side-wettable TQFN package and is specified to operate over the -40°C to $+125^{\circ}\text{C}$ automotive temperature range.

The MAX20097 is available in a 28-pin thermally enhanced TSSOP package, but does not have the SPI interface. It includes an open-drain fault flag (FLTB) that goes low in case of an open string, shorted string, or overvoltage activation in any one of the channels, or in the event of thermal shutdown.

V_{CC} Supply

The V_{CC} supply is the low-voltage digital and analog supply for the chip and derives power from the input voltage from IN to GND. An internal power-on reset (POR) monitors the V_{CC} voltage and the IN voltage. A POR low is generated when V_{CC} goes below its UVLO threshold, causing the IC to be reset. The chip comes out of the reset state once the input voltage goes back up and the V_{CC} regulator output is back in regulation. Bypass V_{CC} to GND with a minimum of 1 μF ceramic capacitor as close as possible to the device. In certain applications when an external regulated 5V supply is available, IN and V_{CC} can be connected together and the regulated 5V can be applied directly to V_{CC}, saving the power dissipation in the internal regulator of the device. The internal V_{CC} regulator is capable of delivering 10mA to external circuitry on V_{CC}.

Buck LED Driver

The ICs use a new average current-mode-control scheme to regulate the current in the output inductor of the buck LED drivers. The inductor current is not directly sensed. In case of a synchronous buck LED driver, the ICs sense the current in the bottom synchronous switch for both channels. In a buck converter, when operating in continuous-conduction mode when the top switch is turned off, the current in the inductor also flows in the bottom switch or diode. This peak current is I_P . When the bottom switch or diode is turned off and the top switch is then turned on, the current in the switch is the same as the current in the inductor, which is I_V . The average current in the inductor is given by $I_{AV} = 0.5(I_P + I_V)$. I_{AV} is the same as the output current I_O . If the bottom switch or diode current is sensed at exactly half of the bottom switch/diode period, the current in the switch/diode would be I_{AV} . This fact is used by the new average current-mode-control scheme to regulate the inductor current when the buck converter is operating in continuous conduction mode.

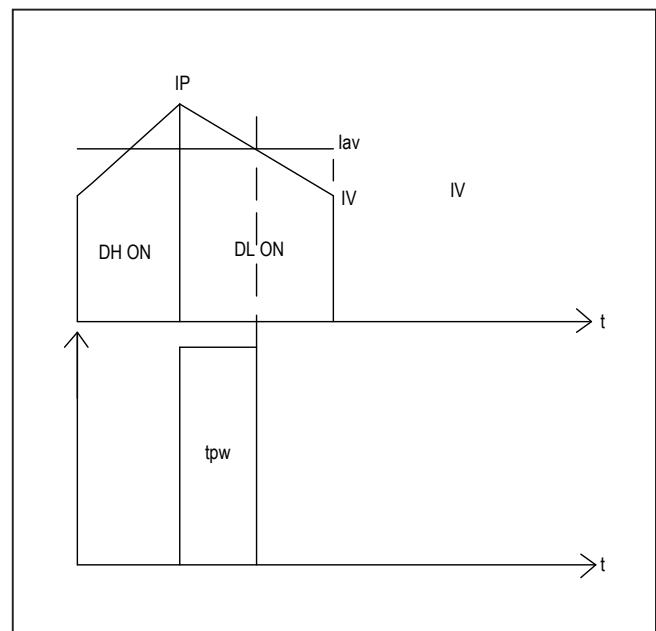

Figure 1. Inductor Current Waveform in One Full Switching Cycle

Switching Frequency

The on-time for Channel 1 is determined based on the external resistor (R1) connected between T_{ON1} and the input voltage, in combination with a capacitor (C1) between R1 and AGND/PGND pins. The input voltage and the R1 resistor set the current sourced into the capacitor (C1), which governs the ramp speed. The ramp threshold is proportional to scaled-down feedback of the output voltage at the OUT pin. The proportionality of V_{OUT} is set by an external resistor-divider (R2, R3) from V_{OUT}.

$$t_{ON} \times V_{IN}/R1 = C1 (V_{OUT} \times R3/(R3 + R2))$$

$$t_{ON} = K \times V_{OUT}/V_{IN}$$

where $K = C1 \times R3 \times R1/(R3 + R2)$

In the case of a buck converter, $t_{ON} \times V_{IN}$ is also given by:

$$t_{ON} = V_{OUT}/V_{IN} \times f_{SW}$$

where f_{SW} is the switching frequency.

Based on that, the switching frequency in case of the new average current-mode-controlled architecture is given by:

$$f_{SW} = 1/K \text{ or } f_{SW} = (R3 + R2)/(C1 \times R3 \times R1)$$

The switching frequency is independent of input and output voltage and is held fixed. In the actual application, there will be slight variations in switching frequency due to the drops in the switches and the inductor. These drops were ignored in the calculations for switching frequency. For Channel 2, the switching frequency is given by

$$f_{SW} = (R6 + R5)/(C2 \times R6 \times R4)$$

Analog Dimming

Analog dimming is performed by controlling the LED current amplitude during operation in both output channels.

Analog Dimming Through the SPI Interface (MAX20096 Only)

For analog dimming through the SPI registers, the CNFG_SEL bit in the CNFG_GEN (0X02) register needs to be set at 1. Once this bit is set at 1, the LED current in channel 1 is programmed by the contents of the CNFG_CRNT1 (0X03) register, and by CNFG_CRNT2 (0X04) for LED current in channel 2. The programmed LED current in channel 1 is given by:

$$I_{LED1} \text{ SET} = ((\text{CNFG_CRNT1}[6:0](\text{dec}) \times 1.25/127) - 0.2)/5 \times R_{CS1} \text{ in Amps}$$

The LED current for channel 2 is given by:

$$I_{LED2} \text{ SET} = ((\text{CNFG_CRNT2}[6:0](\text{dec}) \times 1.25/127) - 0.2)/5 \times R_{CS2} \text{ in Amps}$$

Analog Dimming Through REFI_ Pins

For this configuration, the CNFG_SEL bit in the CNFG_GEN register is set at 0 in the MAX20096. Once this is set at 0, the analog dimming is controlled by the analog dimming pins (REFI1 and REFI2). The voltage at REFI_ sets the LED current level when V_{REFI_} < 1.2V. The LED current can be linearly adjusted from zero with the voltage on REFI_. For V_{REFI_} > 1.3V, an internal reference sets the LED current. The maximum withstand voltage of this input is 5.5V. The LED current is at zero when V_{REFI_} is below 0.2V. In the MAX20097, analog dimming is similar to the analog dimming through the MAX20096 REFI_ pins.

The equation for setting the LED current is given by

$$I_{LED_} = (V_{REFI_} - 0.2)/(5 \times R_{CS_})$$

PWM Dimming

The ICs support PWM dimming. PWM dimming is the preferred method of dimming because it maintains the LED color, regardless of the brightness. In PWM dimming, the LED current-waveform frequency is constant and the duty cycle is set according to the required light intensity. To avoid flicker issues the PWM dimming frequency should be set above 200Hz.

The MAX20096 handles two distinct PWM dimming modes (external and internal), depending on the SPI parameters (PWM1_SEL and PWM2_SEL) in the CNFG_GEN register.

In the MAX20097, there is no SPI interface and therefore no PWM dimming through the SPI interface.

PWM Dimming Through DIM_ Pins

The two independent inputs (DIM1 and DIM2) handle the PWM dimming signals for the two independent channels. This mode is selected independently for channel 1 by PWM1_SEL = 0, and PWM2_SEL = 0 for channel 2. These bits are found in the CNFG_GEN register in the MAX20096. For the MAX20097, PWM dimming is controlled directly by the DIM_ pins.

In this mode, the PWM dimming functions with either analog or PWM control signals. For PWM dimming with a pulsating PWM signal, once the internal pulse detector detects three successive edges of a PWM signal with a frequency between 10Hz and 2kHz, the ICs synchronize to the external signal and pulse-width modulates the LED current for that channel at the external DIM_ input frequency with the same duty cycle as the DIM_ input. If an analog control signal is applied to DIM_, the ICs compare the DC input to an internally generated 200Hz ramp to pulse-width-modulate the LED current ($f_{DIM} = 200\text{Hz}$). The output current duty cycle is linearly adjustable from 0% to 100% ($0.2\text{V} < V_{DIM_} < 2.8\text{V}$). Use the following formula to calculate the voltage ($V_{DIM_}$) necessary for a given output-current duty cycle D:

$$V_{DIM_} = (D \times 2.6) + 0.2\text{V}$$

where $V_{DIM_}$ is the voltage applied to DIM_ in volts.

The 200Hz internal ramp for channels 1 and 2 are 180° degrees out of phase, which allows for phase shifting of 180° when the dimming in the two channels are set by an analog voltage on DIM1 and DIM2.

PWM Dimming Through SPI Interface (MAX20096 Only)

This mode is selected independently for buck channel 1 by PWM1_SEL = 1 and for channel 2 by PWM2_SEL = 1. The PWM frequency is common between both channels and is programmable through the PWM_FREQ[2:0] SPI parameter. The PWM dimming frequency is given by:

$$f_{DIM_} = \text{PWM_FREQ}[2:0](\text{dec}) \times 225 + 200\text{Hz}$$

The PWM dimming in each channel is determined by the PWM_DUTY_[9:0] bits. The PWM control signals are out of phase between the two channels. This helps in alleviating EMI problems. Each least significant bit (LSB) change corresponds to 0.1% duty cycle. 100% duty cycle is achieved when the decimal value in the PWM_DUTY_[9:0] bits exceeds 1000. Register values between 1000 and 1023 all provide 100% duty cycle.

Behavior of LED Driver During PWM Dimming

When the internal PWM dimming signal is high the switching of the high-side MOSFET in the buck LED driver is enabled; however, when DIM goes low, both the high- and low-side MOSFETs are turned off. When the internal PWM dimming signal makes a low-to-high transition, the bottom internal MOSFET inside the device is turned on for 180ns and then the bottom switch is turned off and the

top switch turned on. The LED current waveform is shown in [Figure 2](#). The bottom MOSFET is turned on for 180ns to guarantee that the capacitors on the BST_ pin are sufficiently charged to provide adequate gate drive when the top switch is turned on.

Current Monitor

The device includes a current monitor on the I_{OUTV_} pins. The I_{OUTV_} voltage is an analog voltage indication of the inductor current when DIM is high. The current-sense signal on the bottom MOSFET across RCS_ is inverted and amplified by a factor of 5 by an inverting amplifier inside the device. An added offset voltage of 0.2V is also added to this voltage. This amplified signal goes through a sample and hold switch, which is controlled by the DL_ signal. The sample and hold switch is turned on only when DL_ is high (and is off when DL_ is low). This provides a signal on the output of the sample and hold that is a true representation of the inductor current when DIM_ is high. The sample and hold signal passes through an RC filter and then the buffered output is available on the I_{OUTV_} pin. The voltage on the I_{OUTV_} pin is given by:

$$V_{IOUTV_} = I_{LED_} \times RCS_ \times 5 + 0.2\text{V}$$

where $I_{LED_}$ is the LED current, which is the same as the average inductor current when DIM_ is high.

ADC (MAX20096 Only)

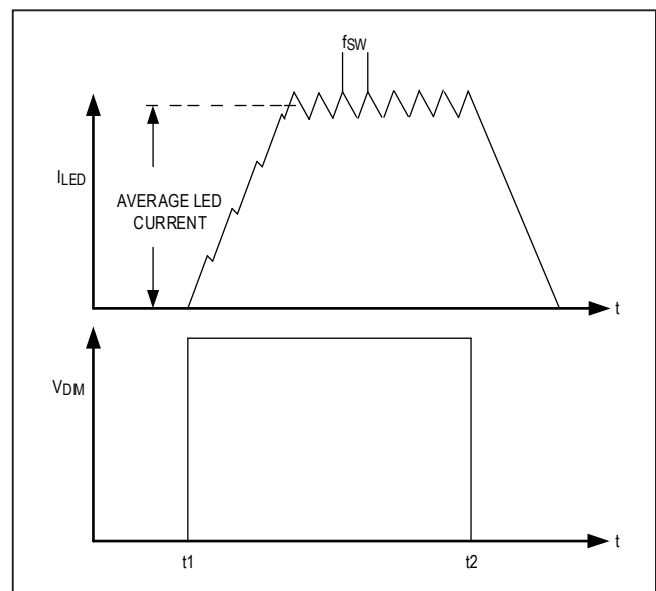

Figure 2. LED Current Waveform with PWM Dimming

General

The MAX20096 has an internal ADC that measures output voltage on both channels, LED currents on both channels, and IC temperature. The output voltage is monitored by measuring the voltage on the OUT_ pin. Fault monitoring and switching-stage output-voltage optimization is possible by using an external microcontroller to read out these digitized voltages through the SPI interface. The ADC is an 8-bit SAR (successive-approximation register) topology. It sequentially samples each of these voltages using a 5-channel multiplexer. Conversions are driven by an internally generated 2MHz clock. For the output voltage, the voltages are sensed on the OUT_ pins; the ADC conversion is also gated by the PWM dimming signal. The ADC samples the output voltage on each channel only when its PWM goes high and after a delay that is set by the DLY_ bits. After a conversion, each measurement is stored into its respective register and can be accessed through the SPI interface.

Note that none of the external microcontroller SPI commands interfere with the internal ADC state-machine sample and conversion operations. The microcontroller always gets the last available data at the moment of the register read. All MAX20096 ADC registers' data integrity is protected by odd parity on bit 8 (i.e., the 9th bit, if counting from the LSB named 0). See the [Register Map](#) section for further details.

Device Temperature ADC (MON_TEMP)

By means of the MON_TEMP measurement, the MCU can monitor the device junction temperature (T_J) over time. The conversion formula is: $T_J = ((TEMP[7:0] \times 523)/255) - 272^\circ\text{C}$, where MON_TEMP[6:0] is the value read out directly from the related 8-bit SPI register (see the [Register Map](#)

section). The value is also used internally by the device for the thermal-warning and thermal-shutdown functions.

Output Voltages (MON_VBUCK1 and MON_VBUCK2)

The voltages on OUT1 and OUT2 are measured by the ADC. The output voltages on each of the LED channels are determined by the formula:

$$V_{\text{BUCK1}} = \text{MON_VBUCK1}[7:0](\text{dec}) \times 2.5 \times \frac{1}{(R2 + R3)(255 \times R3)} \text{ in volts}$$

$$V_{\text{BUCK2}} = \text{MON_VBUCK2}[7:0](\text{dec}) \times 2.5 \times \frac{1}{(R5 + R6)(R6 \times 255)} \text{ in volts}$$

The output voltage is sampled only when the PWM dimming is high after a delay set by the DLY_ bits. This information is used to determine the status of the LED strings. This is used to determine if an individual LED is shorted, or if the string is shorted to GND or if it is shorted to battery. This feature can be exploited by MCU-embedded algorithm diagnostics to read the LED channel's voltage even when in the OFF state, before enabling the LED strings at power-up.

Output Current (MON_ILED_)

The MON_ILED1 and MON_ILED2 registers indicate the current flowing out of Channel 1 and Channel 2, respectively. The actual currents in channels 1 and 2 are given by the following equation:

$$I_{\text{LED1}} = ((2.5\text{V} \times \text{IMON1}[7:0]/255) - 0.2\text{V}) / (5 \times R_{\text{CS1}})$$

$$I_{\text{LED2}} = ((2.5\text{V} \times \text{IMON2}[7:0]/255) - 0.2\text{V}) / (5 \times R_{\text{CS2}})$$

The ADC samples the voltage on IOUTV1 and IOUTV2.

SPI Interface

Overview

The MAX20096 interface is SPI/QSPI/Microwire/DSP compatible. The operation and timing criteria of the SPI interface is shown in Figure 3. The MAX20096 is programmed by an (N x 16)-cycle SPI instruction framed by a CSB low interval. The start of the transaction is defined by the SCLK rising edge, following the CSB falling edge (subject to t_{CSH0} and t_{CSS0} timing criteria). Transactions, including a number of SCLK rising edges not evenly divisible by 16, do not qualify for execution (also based on t_{CSA} , t_{CSH1} , and t_{CSQ} timing criteria). Qualified transactions are executed on the rising edge of CSB. To abort a command sequence, the rise of CSB must precede a qualified (N x 16th) rising edge of SCLK (meeting the t_{CSA} timing requirement).

The SDI content of the SPI transaction consists of a leading read/write (R/WB) bit followed by address, parity, and input data information. Data is latched into the MAX20096 on SCLK rising edges, subject to setup and hold criteria (t_{DS} , t_{DH}).

SDO is actively driven by the MAX20096 when CSB falls (t_{DOE} timing applies), initially presenting the MSB of the output data (the SPI_ERR bit for all transactions). Following the initial SCLK rising edge, SDO is updated in response to SCLK falling edges, conforming to hold and transition time criteria (t_{DOH} , t_{DOT}), allowing the μ C to

latch the data on SCLK rising edges. When CSB is high, the SDO line is high impedance, allowing other devices to access the SDO bus.

RESETB Behavior

The RESETB pin provides the means of asynchronously resetting the part to fail-safe default modes of operation in the event of an SPI interface failure. The RESETB pin is active low, meaning the reset condition is asserted when the input is low.

In response to RESETB falling, all configuration content is reset to its default state. All write mode transactions to the part, during which RESETB is asserted, are rejected and reported as an interface error (notifying the user the transaction was ignored). The one exception is the CNFG_SPI register, which is not cleared by RESETB and can be written during RESETB, allowing the interface to be configured and continue to operate during RESETB assertions. Read-mode transactions are not impacted. The part remains in reset mode until the RESETB condition is removed by pulling the pin high. After the RESETB assertion is removed, the SPI interface resumes normal operation (subject to t_{RBCS} timing criteria). Control of the part can then be returned to the SPI configuration registers, once the CNFG_SEL bit is programmed.

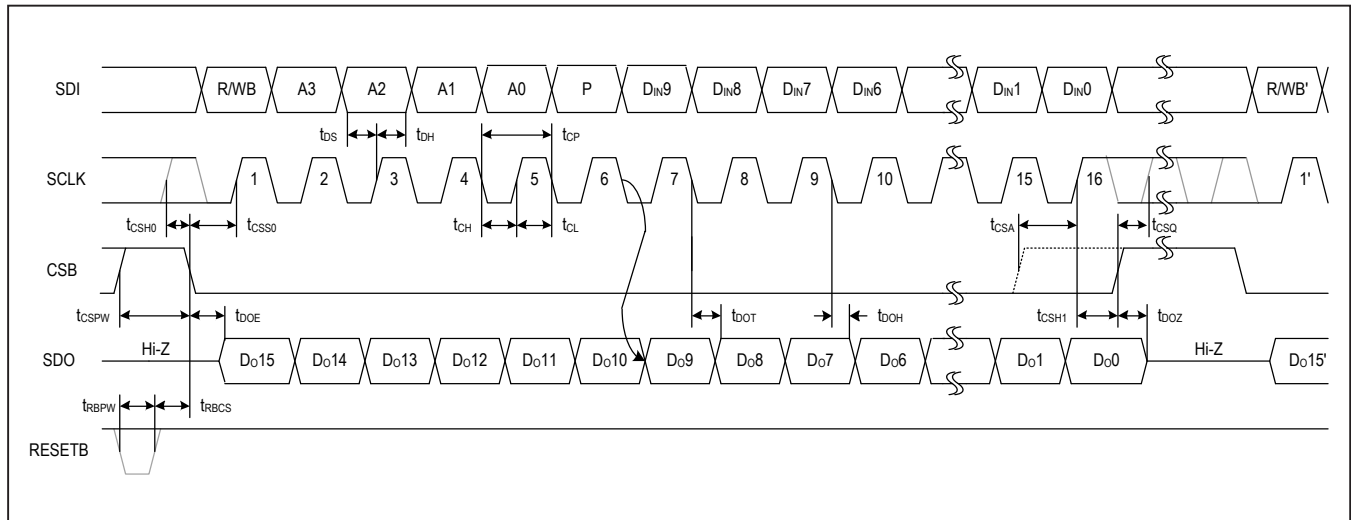

Figure 3. SPI Timing Diagram

Device Connections

The SPI interface ensures compatible operation with standard microcontrollers (μ Cs) from a variety of manufacturers. The μ C always operates as the master and is able to initiate read and write transactions to individual slave devices (using standard connections), or groups of slave devices (using daisy-chain connections) selected by a specific CSB connection. The device(s) always operate in the slave role when connected to a μ C and cannot initiate a SPI transaction.

The SCLK line should be driven by the master and hooked up to all slave devices. Only the slave devices (or group of devices) with its CSB line low will accept SCLK. SPI transactions to the slave devices are defined by SCLK rising edges. The MAX20096 can support SPI formats with (CPOL = 0, CPHA = 0) or (CPOL = 1, CPHA = 1). See [Figure 4](#) for alignment examples.

The SDI line should be hooked up to a master-out-slave-in (MOSI) port. A single SDI line can be routed to all SPI slave devices sharing the interface, but only the slave device (or group of devices) with its CSB line low will accept the SDI data. The μ C should update SDIN in response to SCLK falling edges so the slave can latch data in on SCLK rising edges.

The SDO line should be hooked up to a master-in-slave-out (MISO) port. A single SDO line can be routed to all SPI slave devices sharing the interface, but only the slave device (or group of devices) with its CSB line low can access and drive the shared SDO bus. The slave updates SDO in response to SCLK falling edges so the μ C can latch data in on SCLK rising edges.

Standard (Star) Device Connections (DCHN = 0)

The SPI interface allows multiple devices to share the SPI interface, with the active device for the transaction being selected by pulling its unique CSB port low. Note that each slave device on the interface requires a dedicated CSB line from the master. The SCLK, SDI, and SDO lines are common to all devices. A total of (3 + N) lines is required for an interface supporting N slave devices. Transaction-qualification criteria remain in effect, and in write mode the device executes the instructions present in the last 16 bits of a qualified transaction. In read mode, a device operating in standard mode (DCHN = 0) will return the requested data through SDO during the read-mode transaction. A standard connection example is shown in [Figure 5](#).

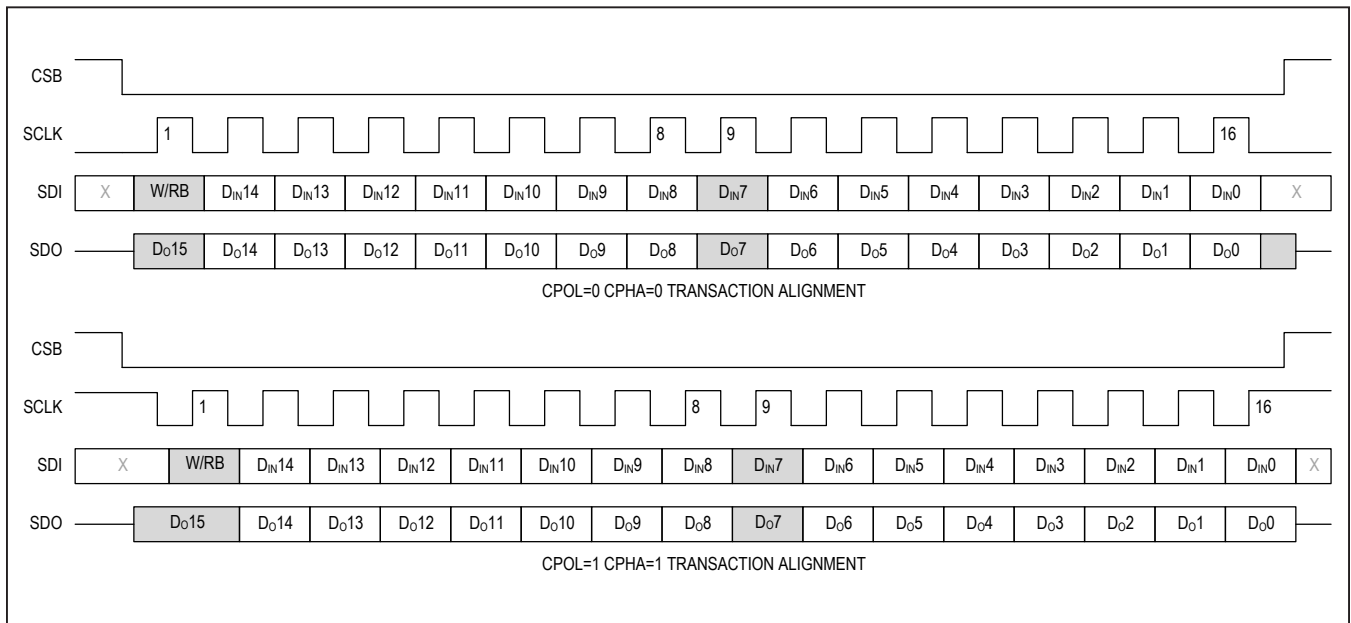

Figure 4. SPI Transaction Format

Daisy-Chain Device Connections (DCHN = 1)

The SPI interface also allows a group of similar devices to share a single CSB line and effectively function as a single extended device employing a daisy-chain connection. In a daisy-chain, the μ C MOSI line is attached to the SDI pin of the first device in the chain. The SDO of each device is then connected to the SDI of the next device in the chain, and the SDO of the final device is connected to the μ C MISO line. The CSB and SCLK lines are common to all devices within the group. A total of four lines are required for an interface supporting a group consisting of any number of devices; however, the SPI transaction length becomes $N \times 16$ bits, where N is the number of devices in the group or chain.

Transaction-qualification criteria remain in effect, and in write mode each device executes the instructions present in the last 16 bits of a qualified transaction. In read mode, once properly configured ($DCHN = 1$), a daisy-chained array of devices register the request for data to be read back based on the last 16 bits of a qualified transaction. The requested data is then read back through the SDO pin by each device in the chain during the initial 16-bit data frame of the following transaction, allowing the data from all

devices to be read back in a single extended transaction, regardless of whether the following transaction is a read or write mode (minimizing communication overhead).

A daisy-chain connection example is shown in [Figure 5](#). All daisy-chain examples use the conventions shown in [Figure 5](#). The top device in the chain (SDI connected to MOSI) is referred to as device N , while the bottom device in the chain (SDO connected to MISO) is device 1.

Status/Address-Selection Bit (ST/AB)

This configuration bit is only used in daisy-chain mode and tells the MAX20096 if the internal transaction log (LOG[15:0]) assembled in response to a read mode transaction will include up to four bits of device status information ST[3:0] (ST/AB = 1) or the address requested A[3:0] (ST/AB = 0).

Daisy-Chain Initial Configuration Example

Upon power-up, the μ C must first configure the grouped devices in daisy-chain mode ($DCHN = 1$). This is required to ensure predictable read mode behavior for all future transactions; write mode behavior is identical for standard and daisy-chain configured devices.

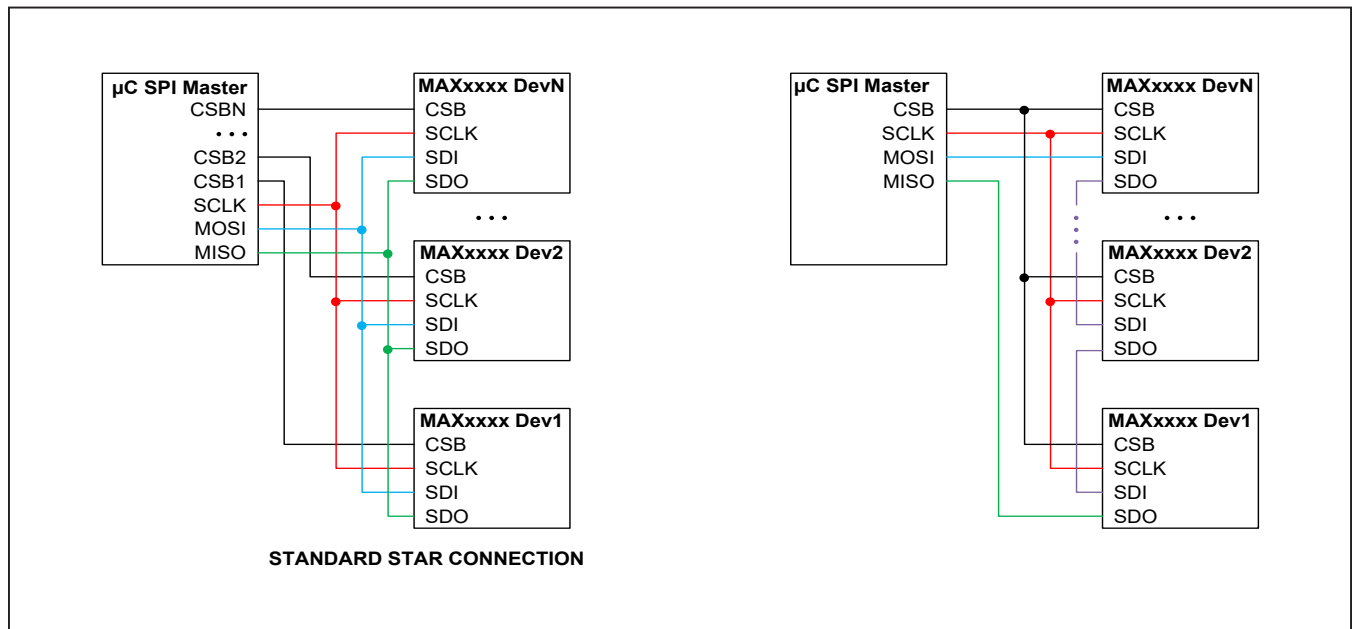

Figure 5. SPI Connection Options

In order to configure N devices in daisy-chain mode, issue a SPI write mode transaction N x 16 SCLK cycles in length writing the CNFG_SPI register N times with DCHN = 1. Other aspects of the interface could also be configured at this time, depending on part options. During this transaction, the devices will present the Initial Transaction Log on their SDO ports, allowing the μC a chance to confirm integrity of the connection. An illustration of the transaction is shown in Figure 6.

Daisy-Chain Write-Mode Example

Once properly configured, daisy-chained devices are always addressed as a group. Only full N x 16-bit frames

should be used with a chain of N devices. NO-OP commands should be used when it is necessary to write to some devices in the chain, leaving the others untouched.

Figure 7 shows an example of a multiple-transaction write-mode operation to arbitrary configuration registers. Although here each transaction wrote to the same register address for all devices (albeit with different data to each device), this is not required. Also note the μC can confirm the previous write-mode transaction during the next transaction (regardless of read/write mode). Finally, a NO-OP transaction shows how the 2nd transaction can be verified without disturbing register contents.

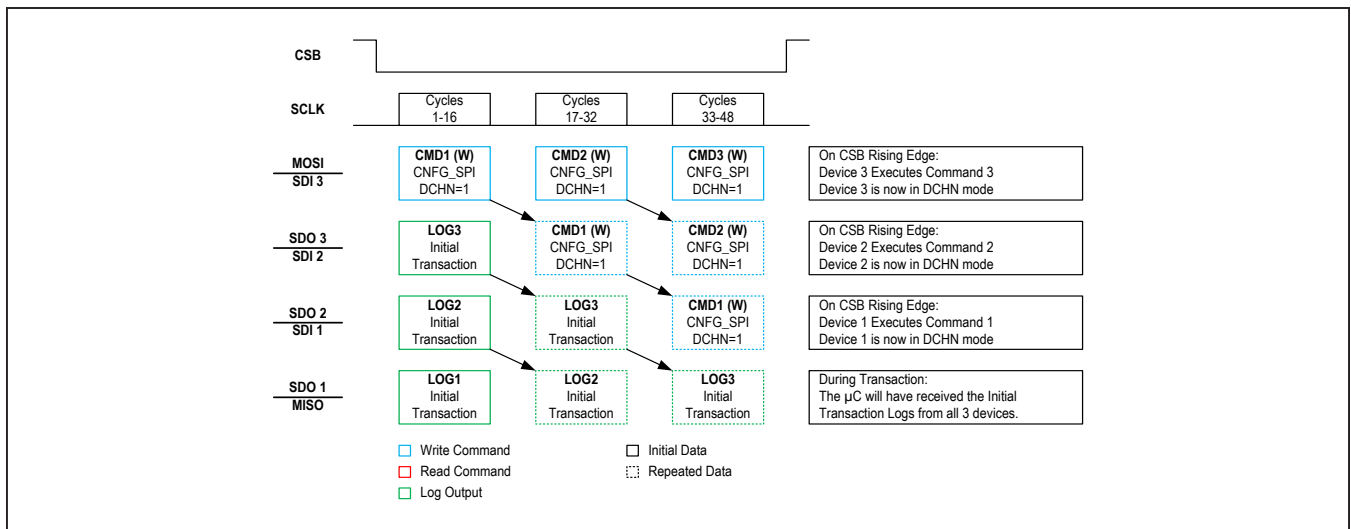

Figure 6. Configuring a Group of Daisy-Chained Devices

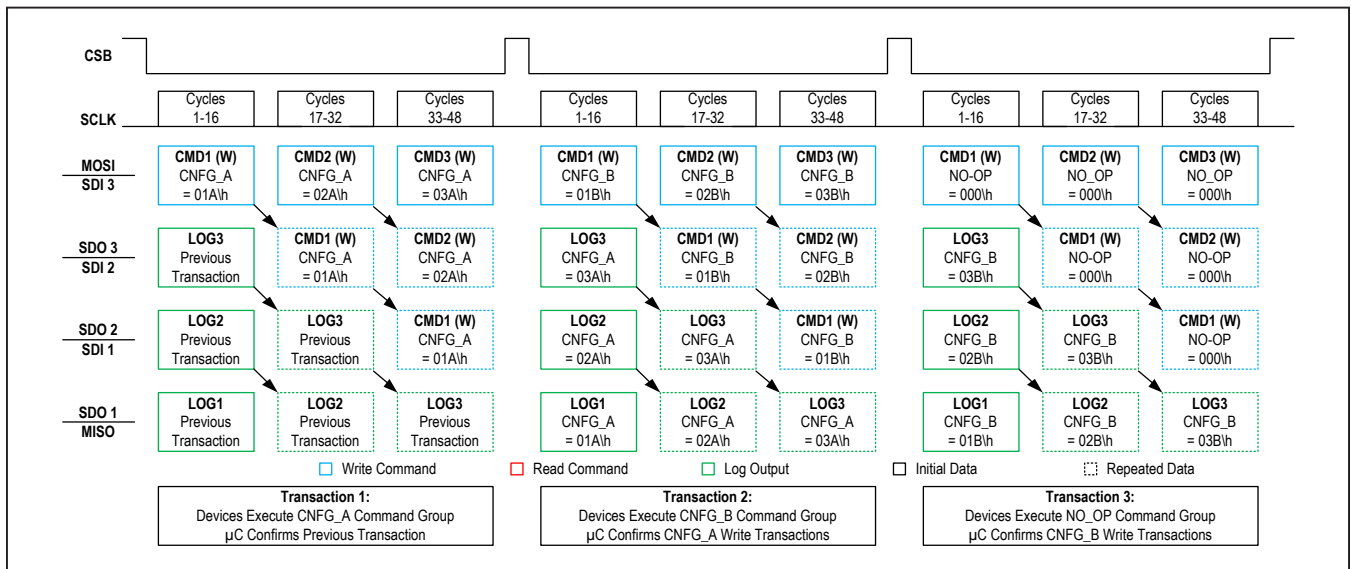

Figure 7. Writing to a Group of Daisy-Chained Devices

Daisy-Chain Read-Mode Example

Once properly configured, daisy-chained devices are always addressed as a group. Only full N x 16-bit frames should be used with a chain of N devices. Note that in a daisy-chain, a read transaction is always interpreted as a request for data, with the requested data being provided during the following transaction within the internal transaction log (LOG).

Figure 8 shows an example of a multiple-transaction read-mode operation from arbitrary supervisory monitor registers. Here each transaction reads from the same address for all devices; this is not required, but may be recommended to simplify record keeping. Also note the μ C receives the previously requested data during the following transaction (regardless of read/write mode).

Note the data provided in the LOG readback frames is fetched during the transaction where it is to be read back (rather than at the end of the transaction where it was requested). This ensures the latest information is provided to the μ C.

Finally, one could imagine continuously repeating transactions 2 and 3 to realize a continuous-monitoring sequence of critical-device performances. Once the sequence is set

up, communication overhead is minimized, since data is continuously provided to the μ C, with negligible latency due to timing of the fetch operation. This sequence can be extended to a series of monitor readback commands of arbitrary length.

Safety PullUp/Pulldown Resistors

To guard against broken SPI interface connections, the MAX20096 includes internal safety terminations on all interface input ports. SCLK and SDI have internal pull-downs to AGND. CSB and RESETB (if present) have internal pullups to V_{IO} . All safety resistors are 100k Ω nominal.

The internal safety resistors can be individually enabled or disabled using SPI configuration bits (SFT_CLK, SFT_SDI, SFT_CSB, SFT_RB) with a high state (default), indicating that safety termination is enabled/engaged and a low state, indicating it is disengaged. This allows the user to eliminate loading currents when the safety resistors are not needed. Note pullup resistors to V_{IO} will still have a resistor and diode connection to V_{IO} + 0.3V to avoid conduction).

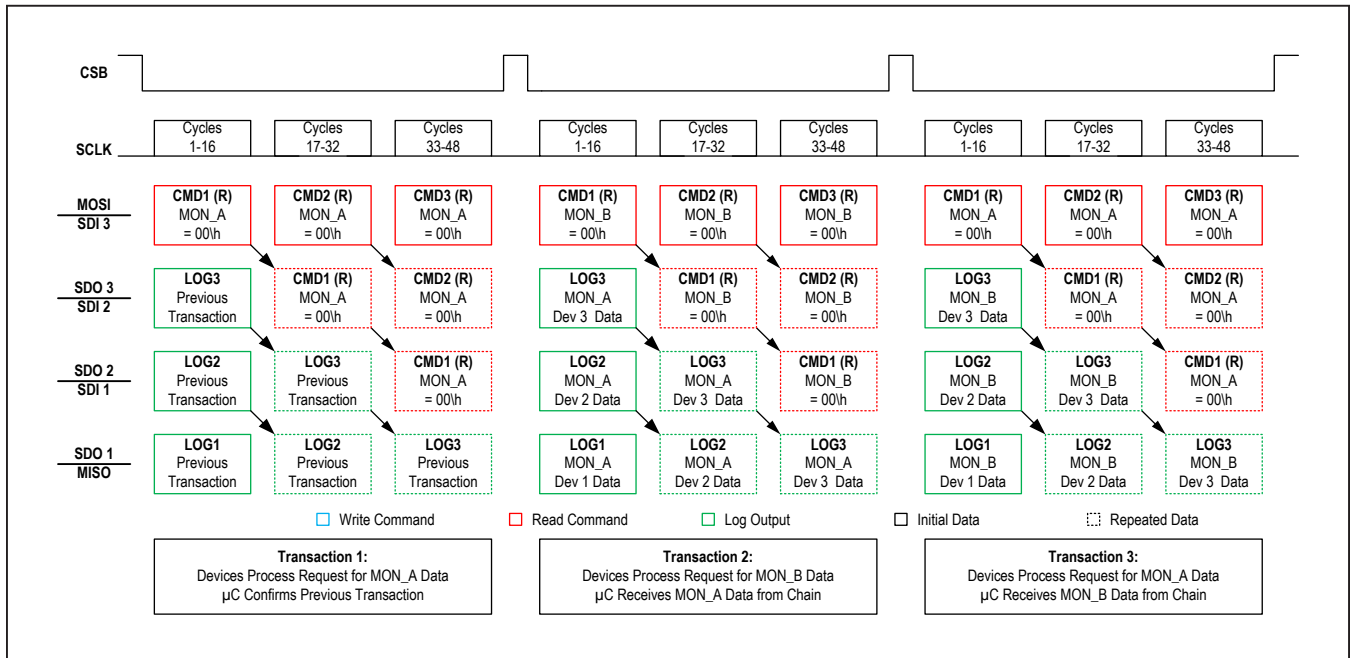

Figure 8. Reading from a Group of Daisy-Chained Devices

SPI Transactions

Write-Mode Transactions

A properly constructed write mode transaction will be made up of N 16-bit data frames. Each SDI data frame from the master (or the previous device in the chain) will contain a R/WB bit, a four bit Address or Command, a parity bit, and ten bits of Input Data or Instructions. During a write mode transaction, the MAX20096 will output data on the SDO line; both transaction log and repeated transaction data will be transferred through SDO. The MAX20096 will only accept and execute qualified SPI transactions, based on the last 16 bits of data received. Details of write mode transactions are explained below and summarized in [Figure 9](#).

Note there is no difference in MAX20096 behavior in standard and daisy-chain configurations during write mode transactions. This is required so that devices hooked up in daisy-chain configurations can be written into daisy-chain mode (DCHN = 1).

Write Bit — R/WB = 0 (DIN15): Write-mode transactions are identified by R/WB = 0 in the MSB position of a 16-bit data frame.

Address — A[3:0] (DIN[14:11]): Write-mode transactions allow new information to be written to internal configuration registers within the device. The configuration register address to be written is indicated by A[3:0] within the data

frame. In this format, up to 16 register addresses are supported (0\h thru F\h) for write-mode access.

SDI Parity Bit — Pin (DIN10): Write-mode transactions are protected by a parity bit (P) facilitating an odd parity check on the SDI data frame. The parity bit for each 16-bit data frame is calculated by the sending device (master) as the inverse of the bit-wise XOR of the 15 bits of information in the data frame. The sending device (master) must embed the correct parity bit (P) within each data frame for the transaction to qualify for execution:

$$P = \text{NOT}(\text{XOR}(R/WB, A3, A2, A1, A0, D9, D8, D7, D6, D5, D4, D3, D2, D1, D0))$$

The receiving device (slave) only accepts/executes the command if the bit-wise XOR of the entire frame content, including the parity bit, is 1 (indicating an odd number of 1s are present in the 16-bit data frame, as received):

$$\text{OK} = \text{XOR}(R/WB, A3, A2, A1, A0, P, D9, D8, D7, D6, D5, D4, D3, D2, D1, D0)$$

Input Data — DIN[9:0] (DIN[9:0]): The 10 LSBs of data in the 16-bit data frame represent data to be written to the requested register, or describe internal operations to be executed.

Output Data — LOG[15:0] and Delayed DIN[15:0]: During write-mode transactions, the MAX20096 outputs data through the SDO line.

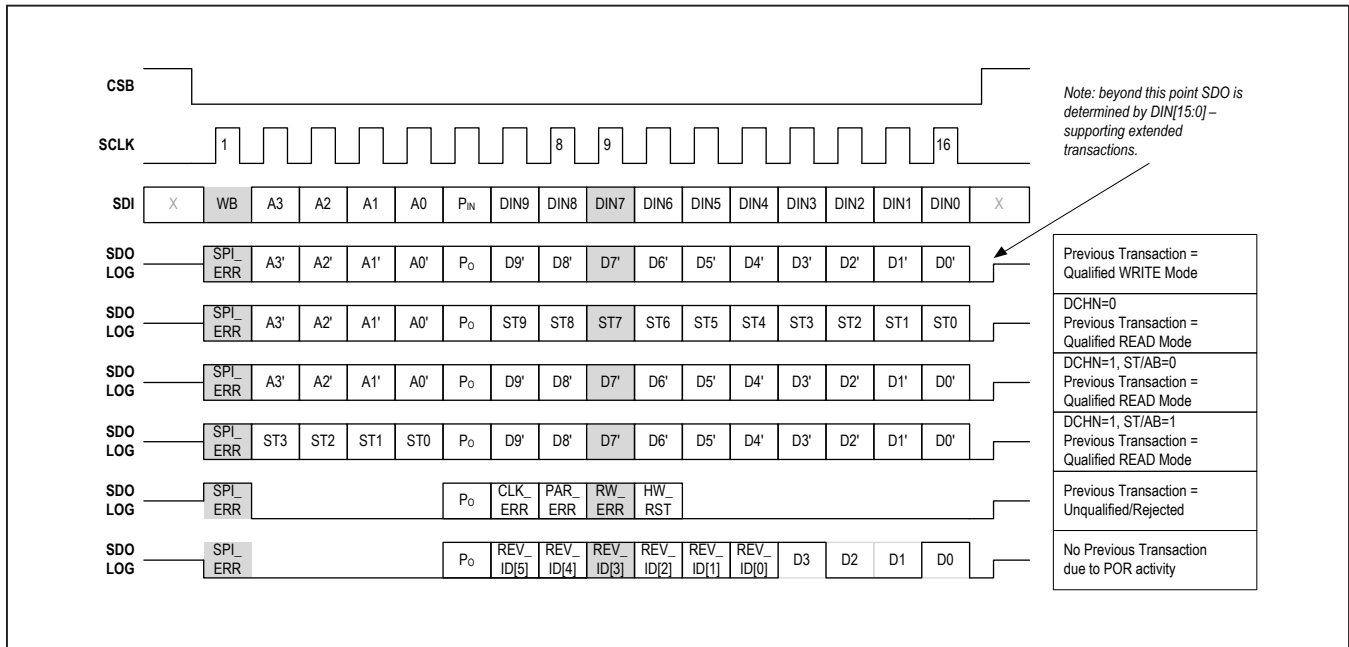

Figure 9. SPI Write-Mode Transactions

In write mode, the MAX20096 relays the contents of the internal transaction log register (LOG[15:0]) through SDO during the 16-bit data frame immediately following the falling edge of CSB. See the [Internal Transaction Log](#) section for a detailed explanation of content.

If further SCLK cycles are provided in the transaction (as required for daisy-chain applications), the MAX20096 relays the previously received SDI data frame with a 16-cycle delay out through the SDO port, providing the previous data frame content without modification. This is required to allow the write-mode instructions to be propagated to the next device in a daisy-chain configuration.

Note: This method also provides the μ C an opportunity to check the SPI interface integrity, since the transaction log content of the previously qualified/executed transaction (N x 16 bits) is relayed back to the μ C through SDO during each complete single or extended transaction.

Write Mode Qualification Check (SPI_ERR): To qualify for write-mode execution, the following conditions must be met:

- SPI transaction must be exactly N x 16 bits in length (no CLK_ERR recorded)
- SDI data frame parity check must pass (no PAR_ERR recorded)
- A[3:0] must select a valid write-accessible register or command (no RW_ERR recorded)
- RESETB must not have been asserted during the transaction (no RW_ERR recorded)

If the SPI transaction is qualified, the instruction is executed, any requested internal register contents are updated, and the internal transaction log updated to indicate the successful transaction.

If the SPI write transaction is not qualified, the instruction is not executed, the device's internal SPI_ERR indicator and appropriate SPI diagnostic bit are set, and the internal transaction log updated to indicate the failed transaction. The SPI_ERR bit is returned in response to later read- and

write-mode transactions, notifying the μ C that the SPI interface may be compromised.

Read-Mode Transactions

A properly constructed read-mode transaction is made up of N 16-bit data frames. Each SDI data frame from the master (or the previous device in the chain) contains a R/WB bit, 4-bit address request, parity bit, and 10 bits of data set to all zeros (000\h). During a read-mode transaction, the MAX20096/MAX20097 output data on the SDO line; the content of the SDO data frame is determined by the device configuration (standard or daisy-chain), as described in detail below. The MAX20096 only accepts qualified SPI transactions, based on the last 16 bits of data received. Details of read-mode transactions are explained below and summarized in [Figure 8](#).

Note: There is no difference in MAX20096 behavior in standard and daisy-chain configurations during read-mode transactions after the initial 16-bit data frame following a CSB falling edge; however, the data presented on SDO during the initial 16-bit data frame depends on the device configuration mode (DCHN and ST/AB). To provide predictable readback results, devices connected in daisy-chain configurations should be written into daisy-chain mode (DCHN = 1) prior to performing any read-mode transactions.

Read Bit — R/WB = 1 (DIN15): Read-mode transactions are identified by R/WB = 1 in the MSB position of a 16-bit data frame.

Address — A[3:0] (DIN[14:11]): Read-mode transactions allow new information to be read from internal registers within the device. The register address to be read back is indicated by A[3:0] within the data frame. In this format, up to 16 register addresses are supported (0\h thru F\h) for read-mode access.

SDI Parity Bit — Pin (DIN10): Read-mode transactions are protected by a parity bit (P), facilitating an odd parity check on the SDI data frame. The parity bit for each 16-bit data frame is calculated by the sending device (master) as the inverse of the bit-wise XOR of the 15 bits of information in the data frame. The sending device (master) must embed the correct parity bit (P) within each data frame for the transaction to qualify for execution, since DIN[8:0] needs to be all zeros for read-mode qualification checks, the parity calculation can be simplified:

$$P = \text{NOT}(\text{XOR}(R/WB, A3, A2, A1, A0, D9, D8, D7, D6, D5, D4, D3, D2, D1, D0))$$

The receiving device (slave) only accepts/executes the transaction if the bit-wise XOR of the entire frame content, including the parity bit, is 1 (indicating an odd number of 1s are present in the 16-bit data frame as received):

$$\text{OK} = \text{XOR}(R/WB, A3, A2, A1, A0, P, D9, D8, D7, D6, D5, D4, D3, D2, D1, D0)$$

Input Data — DIN[9:0] (DIN[9:0]): The 10 LSBs of data in a read-mode 16-bit data frame must be set to zero (000\h).

Standard Output Data — Current Status[3:0] + Data Requested[9:0] and Delayed DIN[15:0]

The MAX20096 operating in standard mode (DCHN = 0) relays the SPI_ERR status, up to 4 bits of general status data (ST[3:0]), a calculated SDO parity bit covering the entire 16-bit SDO frame, and the 10 bits of data requested

by A[3:0] in direct response to an incoming read-mode transaction.

Although not recommended or required in standard read mode, if further SCLK cycles are provided in the transaction (as would be required for daisy-chain applications), the MAX20096 relays the previously received SDI data frame with a 16-cycle delay out through the SDO port, providing the previous data frame content without modification.

Note that standard mode readback data is fetched when A[3:0] is known, and may not be accurate or current if cleared by RESETB activity later during the SPI read transaction.

Daisy-Chain Output Data — LOG[15:0] and Delayed DIN[15:0]

The MAX20096 relays the contents of the internal transaction log (LOG[15:0]) through SDO during the 16-bit data frame immediately following the falling edge of CSB. See the *Initial Transaction Log* section for a detailed explanation of content. Conceptually, in daisy-chain mode, the register data requested from each device with a read-mode transaction will be provided during the following SPI transaction, which is required since daisy-chained devices must execute the command present in the last 16 bits of the transaction. Also, once a device is programmed into daisy-chain mode, there is no difference in SDO content for read- and write-mode transactions. The latest LOG is always returned during the initial 16-bit data frame.

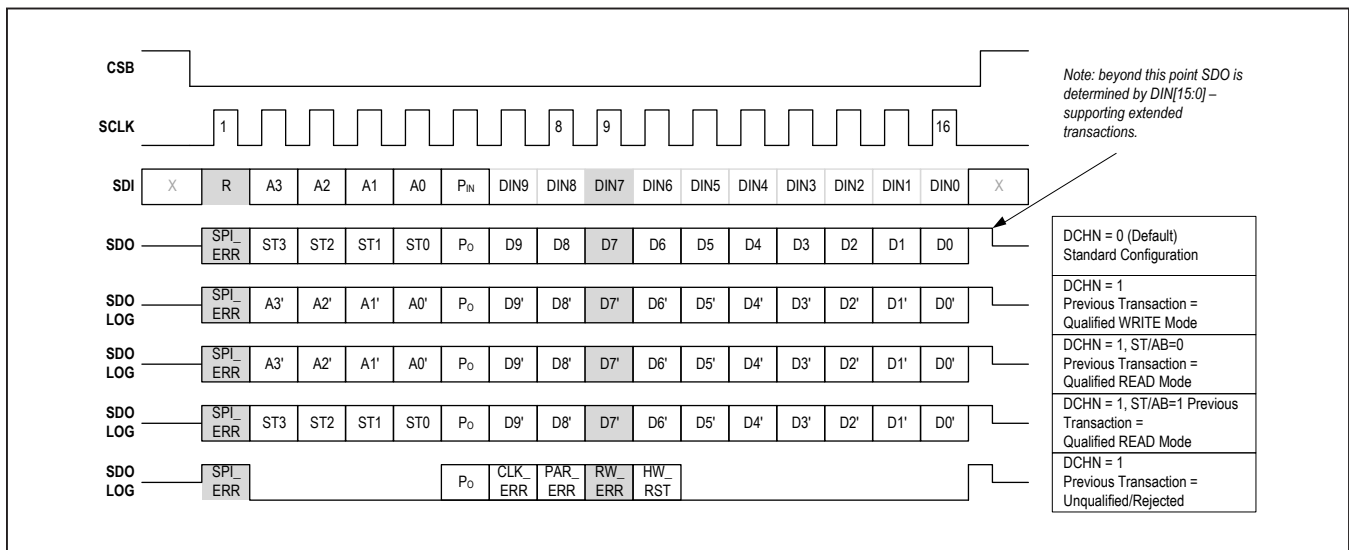

Figure 10. SPI Read Mode Transactions

If further SCLK cycles are provided in the transaction (as required for daisy-chain applications), the MAX20096 will relay the previously received SDI data frame with a 16 cycle delay out through the SDO port, providing the previous data frame content without modification. This is required to allow the read mode instructions to be propagated to the next device in a daisy-chain configuration.

This method also provides the μ C an opportunity to check the SPI interface integrity, since the LOG content of the previously qualified/executed transaction ($N \times 16$ bits) will be relayed back to the μ C through SDO during each complete single or extended transaction.

Note that in daisy-chain mode readback data will be fetched at the beginning of the following SPI transaction, and may not be accurate or current if cleared by RESETB activity later during the SPI transaction.

SDO Parity Bit — Po (DO10)

Like the SDI parity bit, the SDO (PO) bit is calculated as the inverse of the bit-wise XOR of the 15 bits of information in the data frame:

$$P(\text{SDO}) = \text{NOT}(\text{XOR}(\text{R/W}, \text{A/ST3}, \text{A/ST2}, \text{A/ST1}, \text{A/ST0}, \text{D9}, \text{D8}, \text{D7}, \text{D6}, \text{D5}, \text{D4}, \text{D3}, \text{D2}, \text{D1}, \text{D0}))$$

The master can perform an interface parity check on the returned SDO frame, passing the check if the bit-wise XOR of the 16-bit data frame content, including the parity bit, is 1 (indicating an odd number of 1s are present in the 16-bit data frame as received):

$$\text{OK}(\mu\text{C}) = \text{XOR}(\text{SPI_ERR}, \text{A/ST3}, \text{A/ST2}, \text{A/ST1}, \text{A/ST0}, \text{P}, \text{D9}, \text{D8}, \text{D7}, \text{D6}, \text{D5}, \text{D4}, \text{D3}, \text{D2}, \text{D1}, \text{D0})$$

Read-Mode Qualification Check (SPI_ERR):

To qualify for read-mode execution, the following conditions must be met:

- SPI transaction must be exactly $N \times 16$ bits in length (no CLK_ERR recorded)
- SDI data-frame parity check must pass (no PAR_ERR recorded)
- DIN[9:0] must be all zeros (no RW_ERR recorded)

If the SPI transaction is qualified, the instruction is executed, any clear-on-read internal register contents updated, and the internal transaction log updated with the content requested by the successful transaction.

If the SPI read transaction is not qualified, the instruction is not executed, the device's internal SPI_ERR indicator and appropriate SPI diagnostic bit are set, and the internal transaction log updated to indicate the failed transaction. This SPI_ERR bit will be returned in response to later read- and write-mode transactions, notifying the μ C that the SPI interface may be compromised.

SPI_ERR and SPI Diagnostic Bits

In the event the MAX20096 is provided with an unqualified transaction, the SPI_ERR bit will be set to 1, allowing the master to observe the bit and be aware of the problem during every subsequent transaction.

In addition to the SPI_ERR bit, detailed SPI diagnostic bits are available to help diagnose the interface:

- CLK_ERR — Issued for read- or write-mode transactions not exactly $N \times 16$ bits in length
- PAR_ERR — Issued for read- or write-mode transactions that fail parity checks
- RW_ERR — Issued for write-mode transactions to invalid addresses, write-mode transactions during which RESETB was asserted, or read-mode transactions where DIN[9:0] was not 000h

If multiple errors occur during a single transaction, only the first error is reported, in the order of precedence given above. This is done to aid identification of root cause (e.g., a malformed transaction 17 SCLK cycles in length would fail the clock check, but may also fail parity and address checks since the data is also likely misaligned as a result). In such a case, only the CLK_ERR SPI diagnostic bit would be set.

All SPI diagnostic bits are clear-on-read, meaning once asserted, they continue to read back as high until the content is cleared by reading back the SPI configuration register with a qualified read-mode transaction; the MAX20096 keeps a cumulative list of all SPI failure types observed during failed transactions.

Note that transactions processed after any SPI diagnostic bit is set and remains high will be qualified and executed/accepted/logged normally, with their qualification determined by their inclusion in the internal transaction log. Only transactions that individually fail qualification checks are shown as unqualified in the following internal transaction log .

Internal Transaction Log

The internal transaction log (LOG[15:0]) is updated on the CSB rising edge concluding each SPI transaction. The contents of the log are determined by the read/write mode of the transaction, whether the transaction was qualified and executed, and the whether the MAX20096 is configured for standard or daisy-chain connections (DCHN), and if in daisy-chain mode, the setting of the ST/AB configuration bit. Details of internal transaction log content is explained below and summarized in [Table 1](#).

**Write-Mode Transaction Log
(Standard and Daisy-Chain Mode)**

If the completed transaction is qualified/executed in write mode, upon execution, the device stores the current SPI_ERR status, the executed A[3:0], an SDO parity bit, and DIN[9:0] content as LOG[15:0]. This allows the μ C to frequently check SPI interface integrity and respond to the last transaction with minimal communication overhead during every write-mode command issued. **Note:** This is the previously executed transaction data, not the internal content of any registers modified as a result of the transaction. Use a read-mode transaction if an explicit verification of internal register content is desired.

Read-Mode Transaction Log (Standard Mode)

If the completed transaction is qualified in read mode and the device is configured in standard mode (DCHN = 0), the device will provide the current SPI_ERR status, requested

address A[3:0], a calculated SDO parity bit, and the current device status (up to 10 bits) as LOG[15:0]. This allows the μ C to frequently check SPI interface integrity, respond to the last transaction and device status with minimal communication overhead in standard connections during every write-mode command issued. **Note:** The parity and status information provided is fetched during the subsequent write-mode transaction (rather than being latched at the time of read-mode execution), providing the most current device information available.

Read-Mode Transaction Log (Daisy-Chain Mode)

If the completed transaction is qualified in read mode and the device is configured in daisy-chain mode (DCHN = 1), the device provides the current SPI_ERR status, either the requested address A[3:0] or up to 4 bits of status information (ST[3:0] if the ST/AB bit = 0 or 1, respectively), a calculated SDO parity bit, and the requested register data D[9:0] as LOG[15:0]. The initial SDO data frame provided during a following transaction will include the requested readback data from each device in the chain. This allows the μ C to confirm register contents, device status, or requested supervisory/output data in daisy-chain configurations. The register and status information (if applicable) provided is fetched during the subsequent SPI transaction (rather than being latched at the time of execution), providing the most current device information available.

Table 1. Internal Transaction Log Contents

TRANSACTION TYPE	LOG [15]	LOG [14]	LOG [13]	LOG [12]	LOG [11]	LOG [10]	LOG [9]	LOG [8]	LOG [7]	LOG [6]	LOG [5]	LOG [4]	LOG [3]	LOG [2]	LOG [1]	LOG [0]
Qualified Write Mode	SPI_ERR	A[3]	A[2]	A[1]	A[0]	P	D[9]	D[8]	D[7]	D[6]	D[5]	D[4]	D[3]	D[2]	D[1]	D[0]
Qualified Read Mode DCHN = 0	SPI_ERR	A[3]	A[2]	A[1]	A[0]	P	ST[9]	ST[8]	ST[7]	ST[6]	ST[5]	ST[4]	ST[3]	ST[2]	ST[1]	ST[0]
Qualified Read Mode DCHN = 1, ST/AB = 0	SPI_ERR	A[3]	A[2]	A[1]	A[0]	P	D[9]	D[8]	D[7]	D[6]	D[5]	D[4]	D[3]	D[2]	D[1]	D[0]
Qualified Read Mode DCHN = 1, ST/AB = 1	SPI_ERR	ST[3]	ST[2]	ST[1]	ST[0]	P	D[9]	D[8]	D[7]	D[6]	D[5]	D[4]	D[3]	D[2]	D[1]	D[0]
Unqualified/Rejected Transaction	SPI_ERR = 1	0	0	0	0	P	CLK_ERR	PAR_ERR	RW_ERR	HW_RST	0	0	0	0	0	0
Initial Transaction	SPI_ERR r 0	0	0	0	0	P	REV_ID[5]	REV_ID[4]	REV_ID[3]	REV_ID[2]	REV_ID[1]	REV_ID[0]	1	0	0	1

Unqualified Transaction Log

If the previous transaction was unqualified and rejected, the device stores the current SPI_ERR status = 1 as LOG[15], as calculated SDO parity bit as LOG[10], and the current/cumulative SPI diagnostic error and hardware reset status will be returned as LOG[9:6], all remaining LOG bits will be set to zero. This allows the μ C to be made aware of the transaction failure during the following transaction.

Initial Transaction Log

If there was no previous transaction due to a power-cycling event, the device returns the current SPI_ERR status = 0 as LOG[15], zeros in the address space, and a calculated SDO parity bit as LOG[10]. The data bits return the device REV_ID[5:0], along with 9h, allowing the μ C to confirm integrity of the SDO data path and perform an odd-parity check on the initial SPI transaction following a POR event.

Diagnostics

The MAX20096 has several diagnostic features that are mentioned in the following sections.

Description of Different Diagnostics Thermal Warning [TH_WARN]

When the junction temperature exceeds 150°C, the thermal-warning flag is set. Once the flag is set it is cleared on a read, only if the junction temperature is below the thermal-warning threshold.

Thermal Shutdown [TH_SHDN]

Thermal-shutdown temperature is internally fixed at 165°C(typ). Once the junction temperature of the device exceeds this threshold, the thermal-shutdown flag is set. This is intended to protect the device from damage caused by overheating. Once thermal shutdown is activated, switching is turned off on both the buck regulators in the MAX20096, and the TH_SHDN bit is set to 1. Switching restarts when the junction temperature goes below the thermal-warning temperature. The TH_SHDN flag is latched and cleared on read only if the problem has been resolved.

Open LED_ String (OPEN1, OPEN2)

The open LED flag is set in string 1 when the LED current in string 1 is 25% below the programmed value. This is indicated by OPEN1 = 1. The open LED flag is set in string 2 when the LED current is 25% below the programmed value. This is indicated by OPEN2 = 1. Both the OPEN1 and OPEN2 flags are latched, but are cleared

on read if the problem has been resolved. Open detection does not disable the LED strings.

Short LED_ String (SHORT1, SHORT2)

This flag is set when a short is detected in the LED strings. SHORT1 is set when the voltage on OUT1 is below the short threshold programmed in V_SHORT1. SHORT2 is set when the voltage on OUT1 is below the short threshold programmed in V_SHORT2. The flag is cleared on read if the short has been removed. The voltage is monitored only when the PWM dimming for the specific channel is high.

Overcurrent on LED_ String (OVERC1, OVERC2)

The OVERC_ flag is set when the current in the string exceeds the programmed value by 20%. Once this flag is set, the specific output is latched off and the flag is latched. POR cycling is required to reset the flag and restart switching in the faulty channel.

SPI Errors (CNFG_SPI)

Errors in SPI are reported separately in the CNFG_SPI register. See the [Register Map](#) section for more details on these errors.

Read/Write Configuration Registers vs. RESETB (CNFG_SEL = 0/1)

The MAX20096 can be configured by the SPI interface using write-mode transactions to configuration registers. The configuration register contents can also be verified through readback. Write-mode transactions to addresses other than those listed here are not accepted and result in an SPI transaction error being reported. In write mode, all unused bits are don't care (but subject to parity checks). In read mode, all unused bits are read back as low.

All configuration register content is returned to default values if RESETB is asserted. Read-mode transactions for all registers are supported when RESETB is asserted. Write-mode transactions conducted during periods where RESETB is asserted are not accepted and result in an SPI transaction error being reported. The one exception is the CNFG_SPI (1h) register, which allows the SPI interface to continue to operate as configured during and after periods where RESETB is asserted. Detailed information on all configuration registers is provided in the [Register Map](#) section.

If CNFG_SEL = 0, so-called fail-safe mode, the default POR values are used for configuration. If CNFG_SEL = 1, registers 2h through 7h can be programmed and used from these SPI setting.

Register Map

ADDRESS	NAME	MSB							LSB
USER COMMANDS									
0x00	NO_OP[15:8]							REV_ID[5:4]	
	NO_OP[7:0]	REV_ID[3:0]			SDO_TEST[3:0]				
0x01	CNFG_SPI[15:8]							CLK_ERR	PAR_ERR
	CNFG_SPI[7:0]	RW_ERR	HW_RST	DCHN	ST_AB	SFT_RB	SFT_CSB	SFT_CLK	SFT_SDI
0x02	CNFG_GEN[15:8]							—	CNFG_SEL
	CNFG_GEN[7:0]	PWM1_SEL	PWM2_SEL	BUCK1_EN	BUCK2_EN	—	PWM_FREQ[2:0]		
0x03	CNFG_CRNT1[15:8]							VSHORT1[1:0]	
	CNFG_CRNT1[7:0]	—	ILED1[6:0]						
0x04	CNFG_CRNT2[15:8]							VSHORT2[1:0]	
	CNFG_CRNT2[7:0]	—	ILED2[6:0]						
0x05	CNFG_TMNG[15:8]							TM_OUT[1:0]	
	CNFG_TMNG[7:0]	DLY1[3:0]			DLY2[3:0]				
0x06	CNFG_PWM1[15:8]							PWM_DUTY1[9:8]	
	CNFG_PWM1[7:0]	PWM_DUTY1[7:0]							
0x07	CNFG_PWM2[15:8]							PWM_DUTY2[9:8]	
	CNFG_PWM2[7:0]	PWM_DUTY2[7:0]							
—									
0x0A	MON_VBUCK1[15:8]							—	EXCEPT1
	MON_VBUCK1[7:0]	VBUCK1[7:0]							
0x0B	MON_VBUCK2[15:8]							—	EXCEPT2
	MON_VBUCK2[7:0]	VBUCK2[7:0]							
0x0C	MON_LED1[15:8]							—	—
	MON_LED1[7:0]	IMON1[7:0]							
0x0D	MON_LED2[15:8]							—	—
	MON_LED2[7:0]	IMON2[7:0]							
0x0E	MON_TEMP[15:8]							—	—
	MON_TEMP[7:0]	TEMP[7:0]							
0x0F	GEN_STAT[15:8]							TH_SHDN	TH_WARN
	GEN_STAT[7:0]	OVP1	OVERC1	SHORT1	OPEN1	OVP2	OVERC2	SHORT2	OPEN2

NO_OP (0x00)

NO_OP is a read/write access register that has no impact on the ICs' operations. While NO_OP transactions will be qualified and subject to parity checks, all data in NO_OP transactions are ignored and not stored internally.

NO_OP write-mode transactions are primarily useful when modifying register contents of one device in a daisy-chain without disturbing operation of the other devices in the chain.

When read back, NO_OP data content returns the 6-bit Revision ID and 9\h in the lower nibble to allow the μ C to verify the SPI interface operation.

Bit							9	8
Field							REV_ID[9:8]	
Reset							0b000000	
Access Type							Read Only	
Bit	7	6	5	4	3	2	1	0
Field	REV_ID[7:4]				SDO_TEST[3:0]			
Reset	0b000000				0b1001			
Access Type	Read Only				Read Only			

BITFIELD	BITS	DESCRIPTION
REV_ID	9:4	Revision information: TBD on REV_ID value on final schematic
SDO_TEST	3:0	Test pattern: 1001 is always returned in this location for interface checking

CNFG_SPI (0x01)

CNFG_SPI is a read/write access register that controls how the SPI is configured (for standard or daisy-chain connections), and whether the internal safety terminations are engaged.

In read mode, four interface status bits are added. HW_RST notifies the user of RESETB activity, and the SPI interface error indicator bits (_ERR) show what type(s) of SPI transaction errors have occurred for the ICs since CNFG_SPI was last read. Once read back, their status is returned to zero (clear-on-read). SPI_ERR is the combination of the three error indicator bits:

- SPI_ERR = (CLK_ERR or PAR_ERR or RW_ERROR)
- CNFG_SPI is not reset by RESETB, allowing the SPI interface to continue to function as configured during and after RESETB assertions. Write transactions to CNFG_SPI while RESETB is asserted are also accepted, allowing the interface to be configured even in the event of a RESETB fault. CNFG_SPI(1\h) is the only register where these exceptions apply.

Bit								9	8
Field								CLK_ERR	PAR_ERR
Reset								0b0	0b0
Access Type								Read Only	Read Only
Bit	7	6	5	4	3	2	1	0	
Field	RW_ERR	HW_RST	DCHN	ST_AB	SFT_RB	SFT_CSB	SFT_CLK	SFT_SDI	
Reset	0b0	0b0	0b0	0b0	0b1	0b1	0b1	0b1	
Access Type	Read Only	Read Only	Write, Read	Write, Read	Write, Read	Write, Read	Write, Read	Write, Read	

BITFIELD	BITS	DESCRIPTION
CLK_ERR	9	SPI Clock Error Indicator (SPI_ERR term, read only, clear-on-read): 0 = Normal operation 1 = Clock error (at least one SPI transaction rejected due to clock count $\neq N \times 16$)
PAR_ERR	8	Parity Error Indicator (SPI_ERR term, read only, clear-on-read): 0 = Normal operation 1 = Parity error (at least one SPI transaction rejected due to a failed parity check)
RW_ERR	7	Read/Write Error Indicator (SPI_ERR term, read only, clear-on-read): 0 = Normal operation 1 = Write error (at least one SPI transaction rejected for writing to an unsupported address, attempting a write-mode transaction while RESETB is asserted, or reading with DIN[9:0] $\neq 000\text{h}$)
HW_RST	6	Hardware-Reset Indicator (read only, clear-on-read): 0 = Normal operation 1 = RESETB has been asserted since CNFG_SPI was last read (latched behavior: clear-on read for the following CNFG_SPI transaction, only if the reset condition has been removed)
ST_AB	4	Daisy-Chain Readback-Format Selection (used only if DCHN = 1): 0 = Address + data readback format (default) 1 = Status + data readback format
SFT_RB	3	RESETB Safety-Pullup Enable: 0 = Pullup disabled (note that 100k Ω + diode connection to V _{IO} remains) 1 = Pullup enabled (100k Ω connection to V _{IO} , default)
SFT_CSB	2	CSB Safety-Pullup Enable: 0 = Pullup disabled (note that 100k Ω + diode connection to V _{IO} remains) 1 = Pullup enabled (100k Ω connection to V _{IO} , default)
SFT_CLK	1	SCLK Safety-Pulldown Enable: 0 = Pulldown disabled 1 = Pulldown enabled (100k Ω connection to AGND, default)
SFT_SDI	0	SDI Safety-Pulldown Enable: 0 = Pulldown disabled 1 = Pulldown enabled (100k Ω connection to AGND, default)

CNFG_GEN (0x02)

CNFG_GEN is a read/write access register that controls the enabling and disabling of the Bucks, PWM dimming, and sets frequency.

Bit							9	8
Field							—	CNFG_SEL
Reset							—	0b0
Access Type							—	Write, Read
Bit	7	6	5	4	3	2	1	0
Field	PWM1_SEL	PWM2_SEL	BUCK1_EN	BUCK2_EN	—	PWM_FREQ[2:0]		
Reset	0b0	0b0	0b0	0b0	—	0b000		
Access Type	Write, Read	Write, Read	Write, Read	Write, Read	—	Write, Read		

BITFIELD	BITS	DESCRIPTION
CNFG_SEL	8	SPI Configuration Register Selection: 0 = Use default/pin settings to control the MAX20096 (default) 1 = Use CNFG register contents to control the MAX20096
PWM1_SEL	7	PWM Channel 1 Configuration Register Selection (used only if CNFG_SEL = 1): 0 = PWM dimming controlled by PWM DIM pin (default) 1 = PWM dimming controlled by CNFG_PWM registers
PWM2_SEL	6	PWM Channel 2 Configuration Register Selection (used only if CNFG_SEL = 1): 0 = PWM dimming controlled by PWM DIM pin (default) 1 = PWM dimming controlled by CNFG_PWM registers
BUCK1_EN	5	Channel 1 Buck Supply Enable (used only if CNFG_SEL = 1): 0 = Switching supply disabled 1 = Switching supply enabled
BUCK2_EN	4	Channel 2 Buck Supply Enable (used only if CNFG_SEL = 1): 0 = Switching supply disabled 1 = Switching supply enabled
PWM_FREQ	2:0	PWM Dimming-Frequency Selection (common frequency used for each channel if PWMn_SEL = 1): 000: 200Hz 001: 333Hz 010: 400Hz 011: 500Hz 100: 667Hz 101: 1000Hz 110: 2000Hz 111: 200Hz

CNFG_CRNT1 (0x03)

CNFG_CRNT1 is a read/write access register that independently sets the LED output current provided by the MAX20096 output and the output-voltage short-detection thresholds applied on OUT1 for Channel 1.

Bit								9	8
Field								VSHORT1[9:8]	
Reset								0b00	
Access Type								Write, Read	
Bit	7	6	5	4	3	2	1	0	
Field	—	ILED1[6:0]							
Reset	—	0x00							
Access Type	—	Write, Read							

BITFIELD	BITS	DESCRIPTION
VSHORT1	9:8	Output Short Threshold Voltage (VSHORT1): 00: 100mV (VBUCK1[7:0] ≤ 0A/h) 01: 200mV (VBUCK1[7:0] ≤ 14/h) 10: 300mV (VBUCK1[7:0] ≤ 1F/h) 11: 400mV (VBUCK1[7:0] ≤ 29/h) Note: Fault detected when an active OUT1 falls below threshold, based on VBUCK1 measurement result.
ILED1	6:0	Channel 1 LED Current Programmed Level Feedback and Offset Adjusted): $I_{LED1} = ((1.25V \times ILED1[6:0]/127) - 0.2V)/(5 \times R_{CS1})$, alternatively: $V_{REF1_INT} = (1.25V \times ILED1[6:0]/127)$

CNFG_CRNT2 (0x04)

CNFG_CRNT2 is a read/write access register that independently sets the LED output current provided by the MAX20096 output and the output-voltage short-detection thresholds applied on OUT2 for Channel 2.

Bit								9	8
Field								VSHORT2[9:8]	
Reset								0b00	
Access Type								Write, Read	
Bit	7	6	5	4	3	2	1	0	
Field	ILED2[6:0]								
Reset	0x00								
Access Type	Write, Read								

BITFIELD	BITS	DESCRIPTION
VSHORT2	9:8	Output Short Threshold Voltage (VSHORT2): 00: 100mV (VBUCK2[7:0] ≤ 0A\h) 01: 200mV (VBUCK2[7:0] ≤ 14\h) 10: 300mV (VBUCK2[7:0] ≤ 1F\h) 11: 400mV (VBUCK2[7:0] ≤ 29\h) Note: Fault detected when an active OUT2 falls below threshold, based on VBUCK2 measurement result.
ILED2	6:0	Channel 2 LED Current Programmed Level (feedback and offset adjusted): $I_{LED2} = ((1.25V \times ILED2[6:0]/127) - 0.2V)/(5 \times R_{CS2})$, alternatively: $V_{REFI_INT} = (1.25V \times ILED2[6:0]/127)$

CNFG_TMNG (0x05)

CNFG_TMNG sets two types of timing parameters used by the ADC measurement sequencer.

TM_OUT sets the length of time the sequencer will wait for the PWM signal to go high (the output channel is activated) before moving on to the next measurement, ensuring the sequencer does not hang when the PWM duty cycle is zero.

DLY1 and DLY2 bits set the measurement delay from the point where the PWM signal goes high to the beginning of the ADC acquisition cycle. This delay ensures the output voltage has adequate time to settle before being measured.

Bit								9	8
Field								TM_OUT[9:8]	
Reset								0b11	
Access Type								Write, Read	
Bit	7	6	5	4	3	2	1	0	
Field	DLY1[7:4]				DLY2[3:0]				
Reset	0xF				0xF				
Access Type	Write, Read				Write, Read				

BITFIELD	BITS	DESCRIPTION
TM_OUT	9:8	ADC Measurement Sequencer Time Out (for either active channel): $TTM_OUT = (TM_OUT[1:0] + 1) \times 20ms$
DLY1	7:4	MON_VBUCK1 Measurement Delay: $TDLY = DLY1[3:0] \times 20\mu s$; 1us when at 4'b0000
DLY2	3:0	MON_VBUCK2 Measurement Delay: $TDLY = DLY2[3:0] \times 20\mu s$; 1μs when at 4'b0000

CNFG_PWM1 (0x06)

CNFG_PWM1 is a read/write access register that independently controls the PWM duty-cycle setting of the MA20096 output Channel 1.

Bit								9	8
Field								PWM_DUTY1[9:8]	
Reset								0x000	
Access Type								Write, Read	
Bit	7	6	5	4	3	2	1	0	
Field	PWM_DUTY1[7:0]								
Reset	0x000								
Access Type	Write, Read								

BITFIELD	BITS	DESCRIPTION
PWM_DUTY1	9:0	Ch1 PWM Dimming Duty-Cycle Selection: $DCDIM = PWM_DUTY1[9:0]/1000 = PWM_DUTY1[9:0] \times 0.1\%$ (e.g., 000h = 0% (LED1 off), 3E8h to 3FFh = 100% (LED1 always on))

CNFG_PWM2 (0x07)

CNFG_PWM2 is a read/write access register that independently controls the PWM duty-cycle setting of the MAX20096 output Channel 2.

Bit								9	8
Field								PWM_DUTY2[9:8]	
Reset								0x000	
Access Type								Write, Read	
Bit	7	6	5	4	3	2	1	0	
Field	PWM_DUTY2[7:0]								
Reset	0x000								
Access Type	Write, Read								

BITFIELD	BITS	DESCRIPTION
PWM_DUTY2	9:0	Channel 1 PWM Dimming Duty-Cycle Selection: $DCDIM = PWM_DUTY2[9:0]/1000 = PWM_DUTY2[9:0] \times 0.1\%$ (e.g., 000h = 0% (LED2 off), 3E8h to 3FFh = 100% (LED2 always on))

MON_VBUCK1 (0x0A)

MON_VBUCK1 is a read-only access register that reads back the buck output voltage measurements on OUT1 for the MAX20096 output Channel 1.

An exception bit is activated if 1) the PWM signal does not go high before the ADC sequencer timeout counter expires (indicating the channel measurement was skipped due to inactivity), or 2) the PWM on-cycle does not allow sufficient time for the configured measurement delay and ADC sampling interval. See the [CNFG_TMNG \(0x05\)](#) register for details on these related timing settings.

Bit								9	8
Field								—	EXCEPT1
Reset								—	0b0
Access Type								—	Read Only
Bit	7	6	5	4	3	2	1	0	
Field	VBUCK1[7:0]								
Reset	0x00								
Access Type	Read Only								

BITFIELD	BITS	DESCRIPTION
EXCEPT1	8	Channel 1 VBUCK Measurement-Exception Indicator: 0 = Normal operation (VBUCK1 result is valid) 1 = Measurement exception (VBUCK1 result is compromised)
VBUCK1	7:0	Channel 1 Buck Output-Voltage-Measurement Result (8 bits, 2.5VFS, feedback adjusted): $V_{BUCK1} = 2.5V \times (V_{BUCK1}[7:0]/255) \times ((R_{TOP} + R_{BOT})/R_{BOT})$, alternatively: $V_{OUT1} = 2.5V \times (V_{BUCK1}[7:0]/255)$

MON_VBUCK2 (0x0B)

MON_VBUCK2 is a read-only access register that reads back the buck output-voltage measurements on OUT2 for the MAX20096 output Channel 2.

See the [MON_VBUCK1 \(0x0A\)](#) register for further details on registers of this type.

Bit								9	8
Field								—	EXCEPT2
Reset								—	0b0
Access Type								—	Read Only
Bit	7	6	5	4	3	2	1	0	
Field	VBUCK2[7:0]								
Reset	0x00								
Access Type	Read Only								

BITFIELD	BITS	DESCRIPTION
EXCEPT2	8	Channel 2 VBUCK Measurement-Exception Indicator: 0 = Normal operation (VBUCK2 result is valid) 1 = Measurement exception (VBUCK2 result is compromised)
VBUCK2	7:0	Channel 2 Buck Output-Voltage-Measurement Result (8 bits, 2.5VFS, feedback adjusted): $V_{BUCK2} = 2.5V \times (VBUCK2[7:0]/255) \times ((RTOP + RBOT)/RBOT)$, alternatively: $V_{OUT2} = 2.5V \times (VBUCK2[7:0]/255)$

MON_LED1 (0x0C)

MON_ILED1 is a read-only access register that reads back the LED string output current supplied by output Channel 1 during active duty cycles.

Bit								9	8
Field								—	—
Reset								—	—
Access Type								—	—
Bit	7	6	5	4	3	2	1	0	
Field	IMON1[7:0]								
Reset	0x00								
Access Type	Read Only								

BITFIELD	BITS	DESCRIPTION
IMON1	7:0	LED Current Measurement Result (8 bits, feedback and offset adjusted): $I_{LED1} = ((2.5V \times IMON1[7:0]/255) - 0.2V)/(5 \times R_{CS1})$. Alternatively: $V_{IOUTV1} = (2.5V \times IMON1[7:0]/255)$

MON_LED2 (0x0D)

MON_ILED2 is a read-only access register that reads back the LED string output current supplied by output Channel 2 during active duty cycles.

Bit							9	8
Field							—	—
Reset							—	—
Access Type							—	—
Bit	7	6	5	4	3	2	1	0
Field	IMON2[7:0]							
Reset	0x00							
Access Type	Read Only							

BITFIELD	BITS	DESCRIPTION
IMON2	7:0	LED Current-Measurement Result (8 bits, feedback and offset adjusted): $I_{LED2} = ((2.5V \times IMON2[7:0]/255) - 0.2V)/(5 \times R_{CS2})$. Alternatively: $V_{IOUTV2} = (2.5V \times IMON2[7:0]/255)$

MON_TEMP (0x0E)

MON_TEMP is a read-only access register that reads back the temperature measurement supplied by the MAX20096.

Bit							9	8
Field							—	—
Reset							—	—
Access Type							—	—
Bit	7	6	5	4	3	2	1	0
Field	TEMP[7:0]							
Reset	0x00							
Access Type	Read Only							

BITFIELD	BITS	DESCRIPTION
TEMP	7:0	Temperature-Measurement Result (8 bits, TFS full scale): Temperature of die = $((TEMP[7:0] \times 523)/255) - 272^{\circ}C$.

GEN_STAT (0x0F)

GEN_STAT is a read-only access register that reads back general status information from the MAX20096. The register provides information on the dual buck LED output strings, and thermal-monitor operations and warnings.

GEN_STAT[9:0] are combined and returned as ST[3:0] in readback LOGs (for DCHN = 0, and for DCHN = 1, ST/AB = 1) as follows:

ST[3] = OVP = (OVP1 or OVP2)

ST[2] = OVERC = (OVERC1 or OVERC2)

ST[1] = LED_FAULT = (SHORT1 or SHORT2, or OPEN1 or OPEN2)

ST[0] = TH_FAULT = (TH_SHDN or TH_WARN)

Overcurrent conditions still serve as a warning to the customer. Due to configurable current-threshold setting, it is up to the user whether to shut down the buck of the affected channel.

Bit							9	8
Field							TH_SHDN	TH_WARN
Reset							0b0	0b0
Access Type							Read Only	Read Only
Bit	7	6	5	4	3	2	1	0
Field	OVP1	OVERC1	SHORT1	OPEN1	OVP2	OVERC2	SHORT2	OPEN2
Reset	0b0	0b0	0b0	0b0	0b0	0b0	0b0	0b0
Access Type	Read Only	Read Only	Read Only	Read Only	Read Only	Read Only	Read Only	Read Only

BITFIELD	BITS	DESCRIPTION
TH_SHDN	9	Thermal Shutdown (ST[0] term, latched clear-on-read if condition has been resolved): 0 = Normal operation 1 = Device is in Thermal Shutdown (> 155°C, always based on analog supervisory circuit, regardless of CNFG_SEL value)
TH_WARN	8	Thermal Warning (ST[0] term, latched, clear-on-read if condition has been resolved): 0 = Normal operation 1 = Device has exceeded the thermal warning threshold (based on TEMP[7:0] ADC result)
OVP1	7	Channel 1 Overvoltage-Protection (ST[3] term, latched, clear-on-read if condition is resolved): 0 = Normal operation 1 = Buck output overvoltage Detected ($V_{OUT1} \geq 2.5V$, based on VBUCK1[7:0] = FFh ADC result)
OVERC1	6	Channel 1 Overcurrent Condition Detected (ST[2] term, latched, clear-on-read if overcurrent condition is resolved): 0 = Normal operation 1 = Overcurrent Detected (based on IMON1[7:0] > 1.25 x ILED1[6:0] ADC result) Note: This check is only enabled when the ILED1 setting results in $V_{REF1} > 0.325V$ (i.e., ILED1[6:0] $\geq 211h$).

BITFIELD	BITS	DESCRIPTION
SHORT1	5	Channel 1 LED String Short Detected (ST[1] term, latched (clear-on-read if short condition is resolved): 0 = Normal operation 1 = LED string short detected ($V_{OUT1} < V_{SHORT1}$, based on VSHORT1[1:0] setting and VBUCK1[7:0] result) Note: This check is only enabled when the I_{LED1} setting results in $V_{REF1} > 0.325V$ (i.e., ILED1[6:0] $\geq 21h$).
OPEN1	4	LED String Open Detected (ST[1] term, latched, clear-on-read if short condition is resolved) 0 = Normal operation 1 = Undercurrent/open condition detected (based on IMON1[7:0] $< 0.75 \times I_{LED1}[6:0]$) Note: This check is only enabled when the I_{LED1} setting results in $V_{REF1} > 0.325V$ (i.e., ILED1[6:0] $\geq 21h$).
OVP2	3	Channel 2 Overvoltage Protection (ST[3] term, latched, clear-on-read if condition is resolved) 0 = Normal operation 1 = Buck output overvoltage detected ($V_{OUT2} \geq 2.5V$, based on VBUCK2[7:0] = FFh ADC result)
OVERC2	2	Channel 2 Overcurrent Condition Detected (ST[2] term, latched (clear-on-read if overcurrent condition is resolved): 0 = Normal operation 1 = Overcurrent detected (based on IMON2[7:0] $> 1.25 \times I_{LED2}[6:0]$ ADC result) Note: This check is only enabled when the I_{LED2} setting results in $V_{REF2} > 0.325V$ (i.e., ILED2[6:0] $\geq 21h$).
SHORT2	1	Channel 2 LED String Short Detected (ST[1] term, latched (clear-on-read if short condition is resolved): 0 = Normal operation 1 = LED string short detected ($V_{OUT2} < V_{SHORT2}$, based on VSHORT2[1:0] setting and VBUCK2[7:0] result) Note: This check is only enabled when the I_{LED2} setting results in $V_{REF2} > 0.325V$ (i.e., ILED2[6:0] $\geq 21h$).
OPEN2	0	LED String Open Detected (ST[1] term, latched (clear-on-read if short condition is resolved): 0 = Normal operation 1 = Undercurrent/open condition detected (based on IMON2[7:0] $< 0.75 \times I_{LED2}[6:0]$) Note: This check is only enabled when the I_{LED2} setting results in $V_{REF2} > 0.325V$ (i.e., ILED2[6:0] $\geq 21h$).

PCB Layout Guidelines

For proper operation and minimum EMI, PCB layout should follow the guidelines below:

- 1) Large switched currents flow in the IN and PGND pins and the input bypass capacitors. The loop formed by the input bypass capacitor should be as small as possible by placing this capacitor as close as possible to the IN and PGND pins. The input capacitor, device, output inductor, and output capacitor should be placed on the same side of the PCB, with the connections made on the same layer.
- 2) Place an unbroken ground plane on the layer closest to the surface layer with the inductor, device, and the input and output capacitors.
- 3) The surface area of the LX and BST nodes should be as small as possible to minimize emissions.
- 4) The exposed pad on the bottom of the package must be soldered to ground so that the pad is connected to ground electrically and also acts as a heatsink thermally. To keep thermal resistance low, extend the ground plane as much as possible, and add thermal vias under and near the device to additional ground planes within the circuit board. In a synchronous rectifier, the high-speed gate-drive signals can generate significant conducted and radiated EMI. This noise can couple with high-impedance nodes of the IC and result in undesirable operation. A small amount of resistors (4Ω to 10Ω), in series with the gate-drive signals are recommended to slow the slew rate of the LX node and reduce the noise signature. They also improve the robustness of the circuit by reducing the noise coupling into sensitive nodes.
- 5) The parasitic capacitance between switching node and ground node should be minimized to reduce common-mode noise. Other common layout techniques, such as star ground and noise suppression using local bypass capacitors, should be followed to maximize noise rejection and minimize EMI within the circuit.
- 6) Place a capacitor ($C_{BST_}$) as close as possible to the BST_ and LX_ pins.

MAX20096 Buck Matrix Diagram

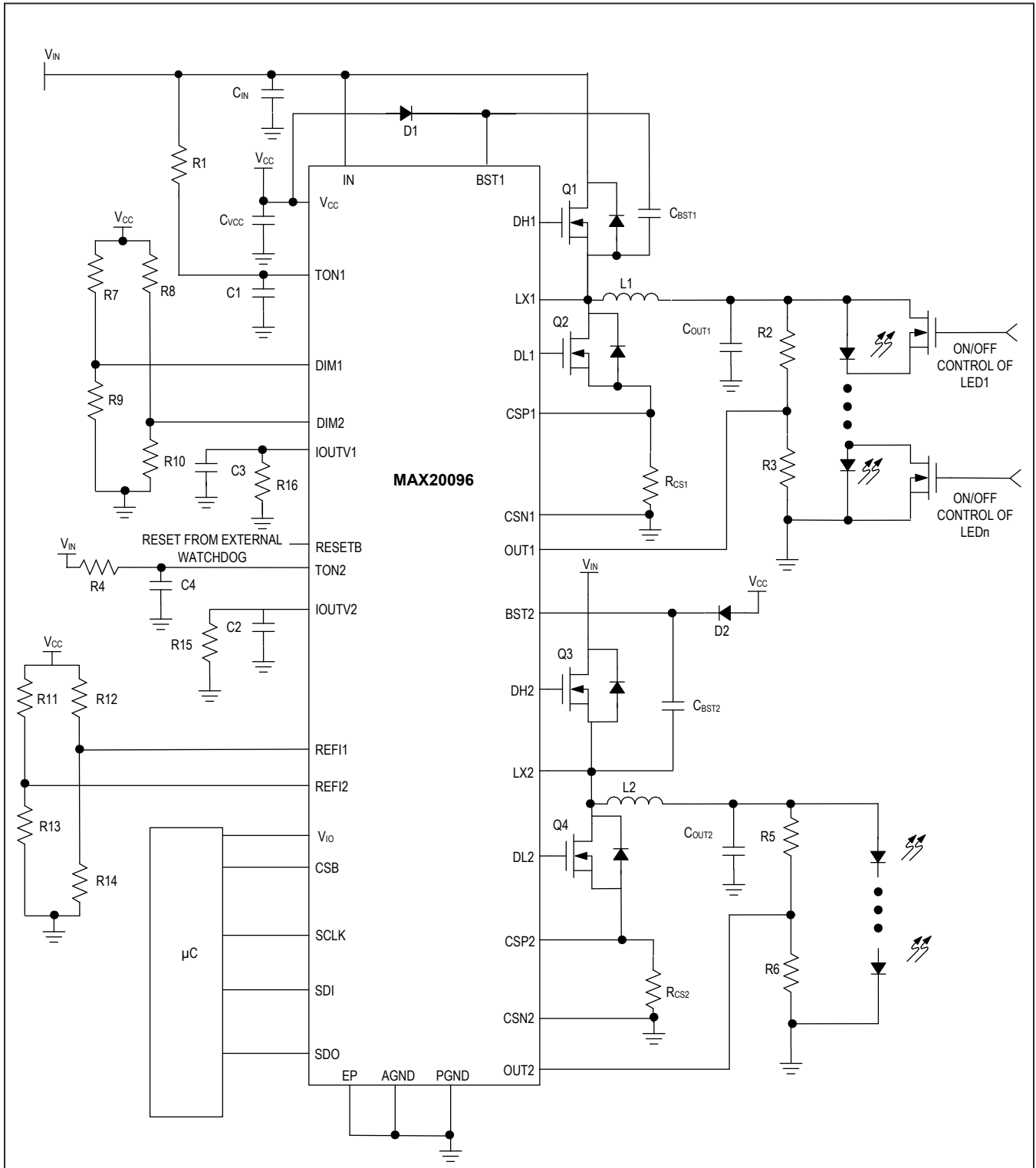

MAX20097 Buck Matrix Diagram

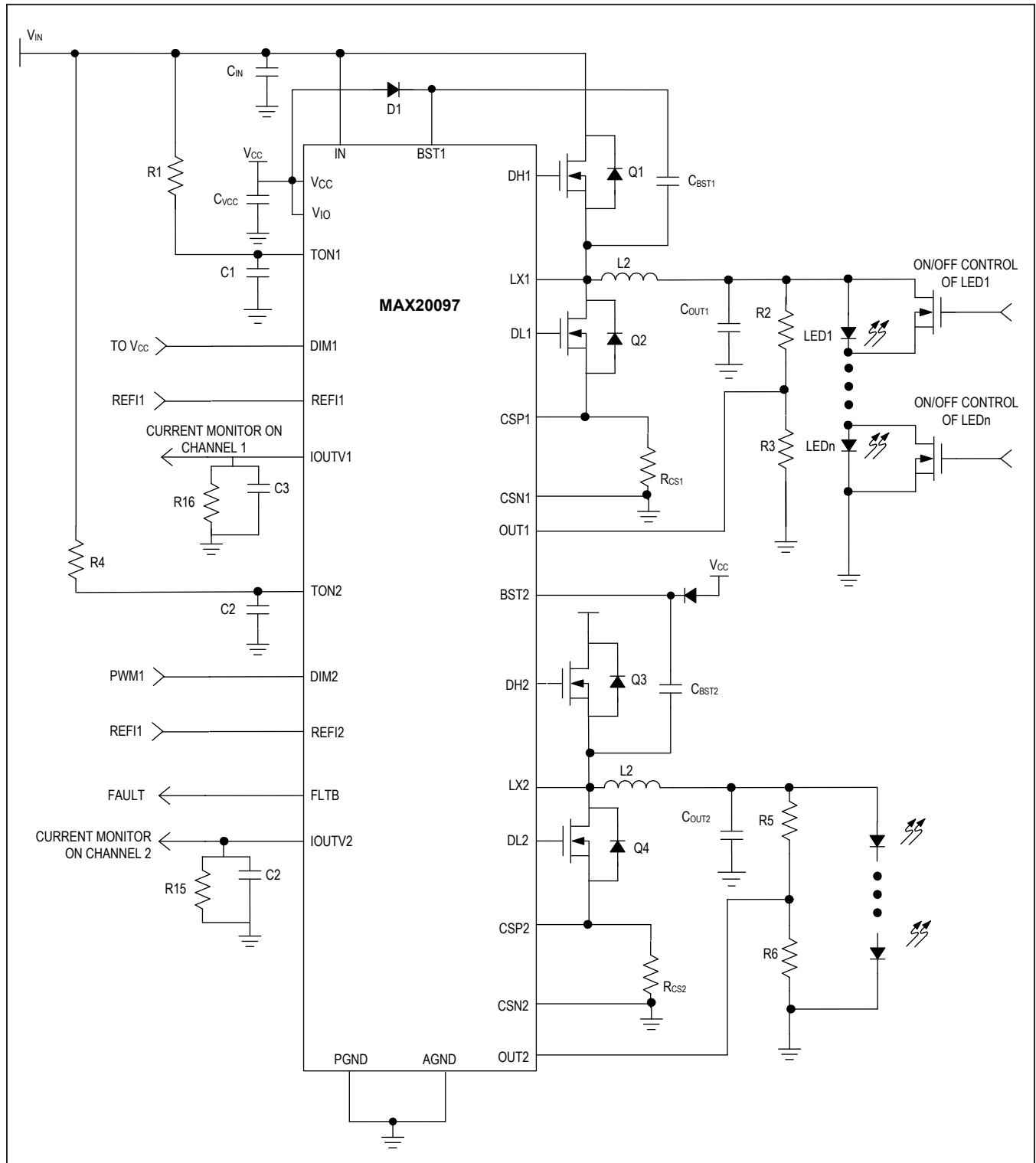

Ordering Information

PART	TEMP RANGE	PIN-PACKAGE
MAX20096ATJ/VY+	-40°C to + 125°C	32 TQFN-EP*
MAX20097ATJ/VY+	-40°C to + 125°C	32 TQFN-EP*
MAX20097AUI/V+	-40°C to + 125°C	28 TSSOP-EP*

V denotes an automotive qualified part.

+Denotes a lead(Pb)-free/RoHS-compliant package.

*EP = Exposed pad.

Chip Information

PROCESS: BiCMOS

Package Information

For the latest package outline information and land patterns (footprints), go to www.maximintegrated.com/packages. Note that a "+", "#", or "-" in the package code indicates RoHS status only. Package drawings may show a different suffix character, but the drawing pertains to the package regardless of RoHS status.

PACKAGE TYPE	PACKAGE CODE	OUTLINE NO.	LAND PATTERN NO.
TSSOP	U28E+1C	21-100182	90-100069
TQFN	T3255Y+6C	21-100041	91-100066

Revision History

REVISION NUMBER	REVISION DATE	DESCRIPTION	PAGES CHANGED
0	6/17	Initial release	—
1	4/18	Removed future product status from MAX20097AUI/V+ in Ordering Information	47
2	2/19	Updated Absolute Maximum Ratings , Package Thermal Characteristics , Electrical Characteristics , Detailed Description , and Ordering Information	2, 4, 6, 18, 19, 47

For pricing, delivery, and ordering information, please visit Maxim Integrated's online storefront at <https://www.maximintegrated.com/en/storefront/storefront.html>.

Maxim Integrated cannot assume responsibility for use of any circuitry other than circuitry entirely embodied in a Maxim Integrated product. No circuit patent licenses are implied. Maxim Integrated reserves the right to change the circuitry and specifications without notice at any time. The parametric values (min and max limits) shown in the Electrical Characteristics table are guaranteed. Other parametric values quoted in this data sheet are provided for guidance.

Looking for pricing, stock, or lifecycle information?

Click below to explore more details on WIN SOURCE:

 [View MAX20096ATJ/VY+T on WIN SOURCE](#)

 [Analog Devices Inc. Information](#)

Optimize Your Supply Chain with WIN SOURCE Solutions

-  Global Sourcing Solution
-  Obsolete Management
-  Cost Control Management
-  Shortage Management
-  Alternative Solution
-  Excess Inventory Management