



**THE DATASHEET OF
LTH3MM12VFR4500**





LTH3MM12V Series

3mm (T-1) Through Hole LED

Built-in Resistor for 12VDC



LTH3MM12VFR4500 - Green Water-Clear T-1 (3 mm) LED

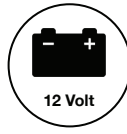

Applications

- Automotive
- Indoor and Outdoor Indication
- Industrial
- Appliances and Consumer Equipments
- Storage Servers
- Boats
- Railway
- Electronic Devices
- Residential and Landscape Lighting
- Infrastructure

Key Features

- Made with InGaN (Green)
- Through-hole technology
- Integrated resistor for 12VDC operation
- With Flange
- Water-Clear Lens
- LED Bulb Size: 3mm (T-1), also available in 5mm (T-1 3/4)
- RoHS and REACH Compliant
- High-Brightness LED
- Available in 5 colors (red, green, white, blue and yellow)
- Viewing Angle: 30° (red, green, blue, yellow) and 35° (white)
- Moisture Sensitive Level (MSL): 2

Ordering Data

The LTH3MM12V Series is available in a range of standard features and options. To specify your LED, simply choose one option from each column.

| Series | Mounting Type | Size | Voltage | Flanged | Shape | Lens Color | Output Color LED | | | | | | | | | | |
|--------|---------------|-------------|------------|-------------|-------------|------------|---|-----|-----|-------|-----|-------|-----|------|-----|--------|-----|
| L | TH | 3MM | 12V | F | R | 4 | | | | | | | | | | | |
| LED | Through-Hole | | 12VDC | With Flange | Round Top | | | | | | | | | | | | |
| | | 3MM 5MM* | 3mm 5mm | | Water Clear | 4 | | | | | | | | | | | |
| | | | | | | | <table border="1"> <tr><td>Red</td><td>100</td></tr> <tr><td>White</td><td>400</td></tr> <tr><td>Green</td><td>500</td></tr> <tr><td>Blue</td><td>600</td></tr> <tr><td>Yellow</td><td>700</td></tr> </table> | Red | 100 | White | 400 | Green | 500 | Blue | 600 | Yellow | 700 |
| Red | 100 | | | | | | | | | | | | | | | | |
| White | 400 | | | | | | | | | | | | | | | | |
| Green | 500 | | | | | | | | | | | | | | | | |
| Blue | 600 | | | | | | | | | | | | | | | | |
| Yellow | 700 | | | | | | | | | | | | | | | | |

| Part Numbers | Color |
|-----------------|--------|
| LTH3MM12VFR4100 | Red |
| LTH3MM12VFR4400 | White |
| LTH3MM12VFR4500 | Green |
| LTH3MM12VFR4600 | Blue |
| LTH3MM12VFR4700 | Yellow |

*For 5mm option, please consult LTH5MM12V Series' datasheet

Product Dimensions

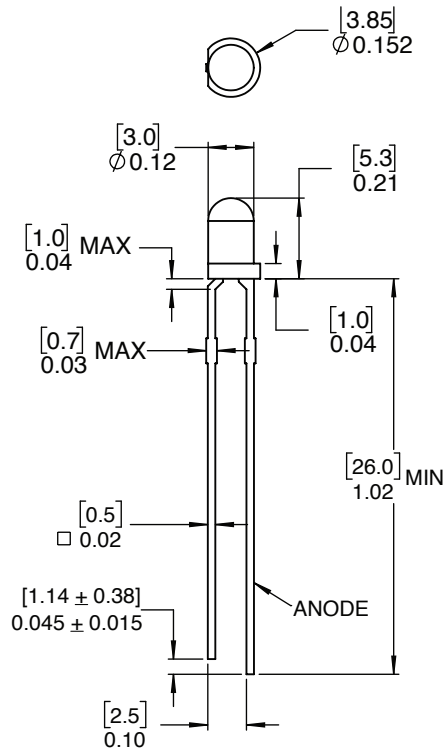

Notes:

1. All dimensions are in [millimeters] inches
2. Tolerance is $\pm[0.25]$ 0.01 unless otherwise noted.
3. The specifications, characteristics and technical data described in the datasheet are subject to change without prior notice

Product Dimensions

ABSOLUTE MAXIMUM RATINGS

(Ta=25°C)

| Parameter | Symbol | Ratings | Unit |
|---|---------------------|---------------------|------|
| Peak Forward Current (duty 1/10 @ 1KHz) | I _{FP} | 100 | mA |
| Recommended Operating Current | I _{F(REC)} | 20 | mA |
| Power Dissipation | P _D | 85 | mW |
| Reverse Voltage | V _R | 5 | V |
| Electrostatic Discharge | ESD | 200 | V |
| Operating Temperature Range | T _{OPR} | -40~+85 | °C |
| Storage Temperature Range | T _{STG} | -40~+100 | °C |
| Lead Soldering Temperature Range 1.6mm (1/16 inch) from body | T _{SOL} | 260°C for 5 seconds | |

OPTICAL-ELECTRICAL CHARACTERISTICS

(Ta=25°C)

| Parameter | Symbol | Test Condition | Min | Typ | Max | Unit |
|--------------------------|-------------------|----------------------|------|------|------|------|
| Luminous Intensity | I _v | I _F =10mA | 3500 | 5000 | 7500 | mcd |
| Peak Emission Wavelength | λ _P | | -- | 522 | -- | nm |
| Dominant Wavelength | λ _D | | -- | 522 | -- | nm |
| Forward Voltage | V _F | | 10 | 12 | 13 | V |
| Spectral Line Half-Width | Δλ | | -- | 36 | -- | nm |
| Viewing Angle | 2θ _{1/2} | | -- | 30 | -- | deg |
| Reverse Current | I _R | V _R =5V | -- | -- | 10 | μA |

Product Specifications

Typical Electrical-Optical Characteristic Curves

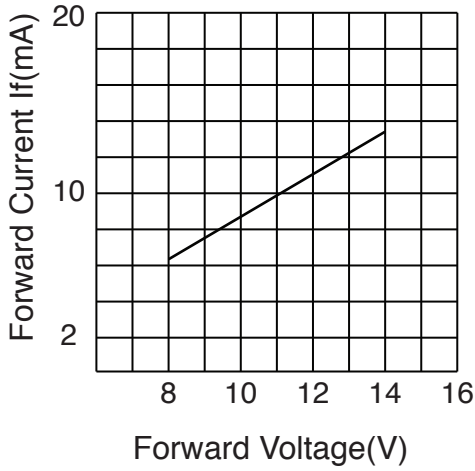

Forward Current vs. Forward Voltage

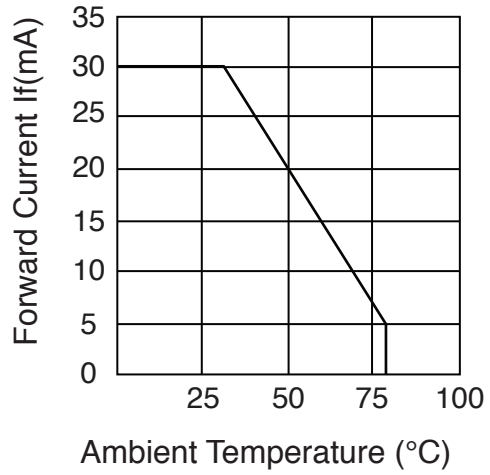

Forward Current Derating Curve

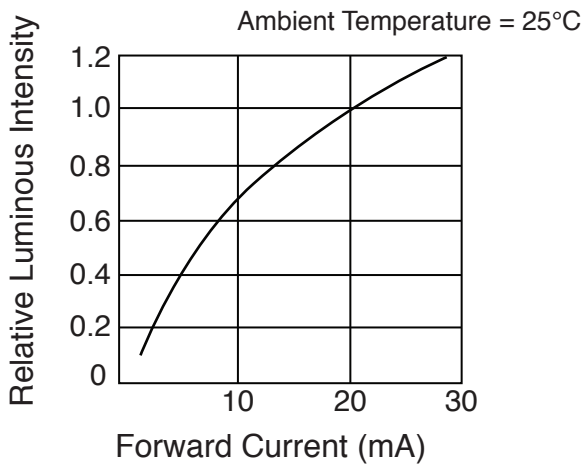

Luminous Intensity vs. Forward current

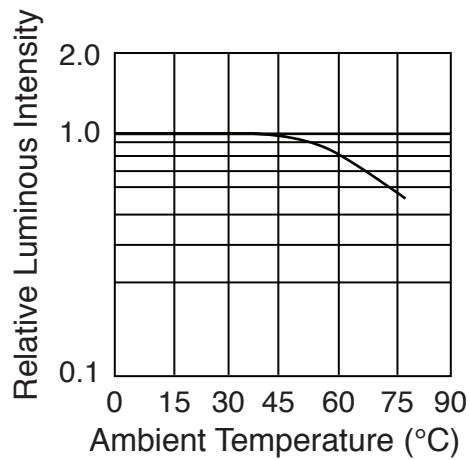

Luminous Intensity vs. Ambient Temperature

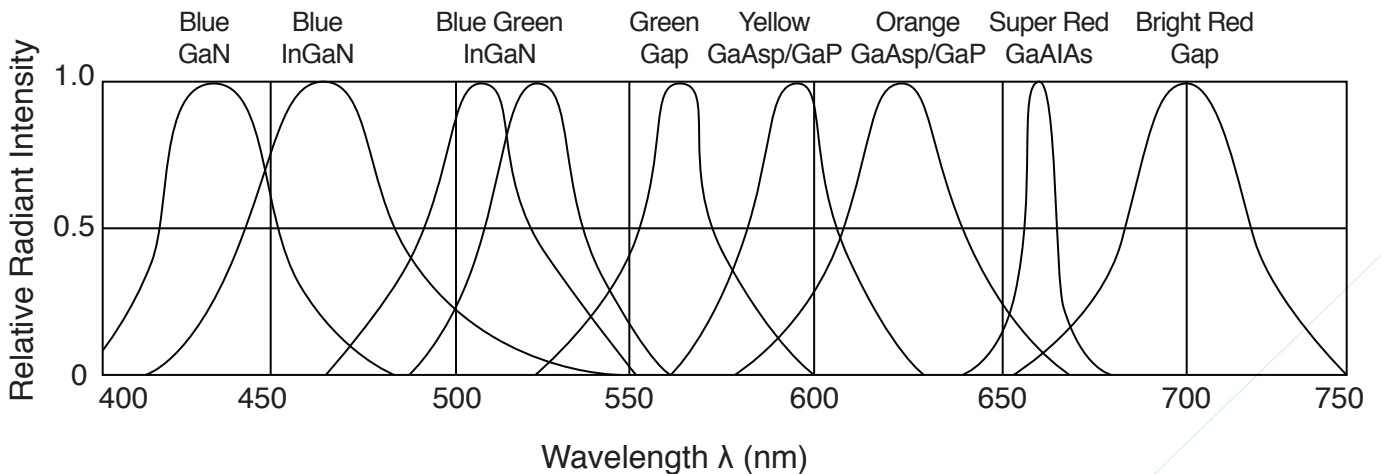

Relative Intensity vs. Wavelength

Application Notes

1. Storage

The Storage Temperature and RH are: 5°C ~ 30°C, RH 60% or less.

We suggest our customers use our products within a year.

If the moisture absorbent material (silica gel) has faded away or the LEDs exceeded the storage time, bake treat more than 24 hours at 60°C ±5°C.

2. Electrostatic Discharge (ESD)

Static electricity or surge voltage will damage the LEDs.

Recommendations: Use a conductive wrist band or anti-electrostatic glove when handling these LEDs. All devices, equipment and machinery must be properly grounded.

Work tables, storage racks, etc. should be properly grounded. In the event of a manual working in process, make sure the devices are well protected from ESD at any time.

3. Recommended Soldering Condition

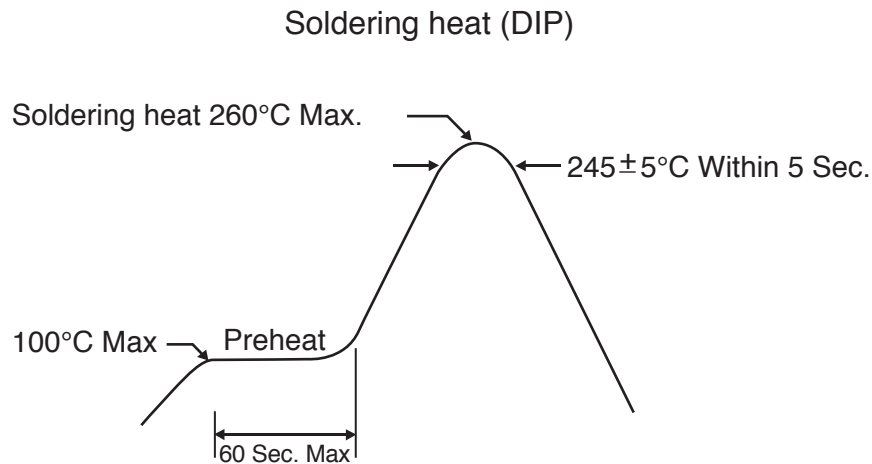

Temperature at tip of soldering iron: 350°C Max

Soldering time: 3 sec ±1 sec (once only)

Application Notes

4. Reflow Profile

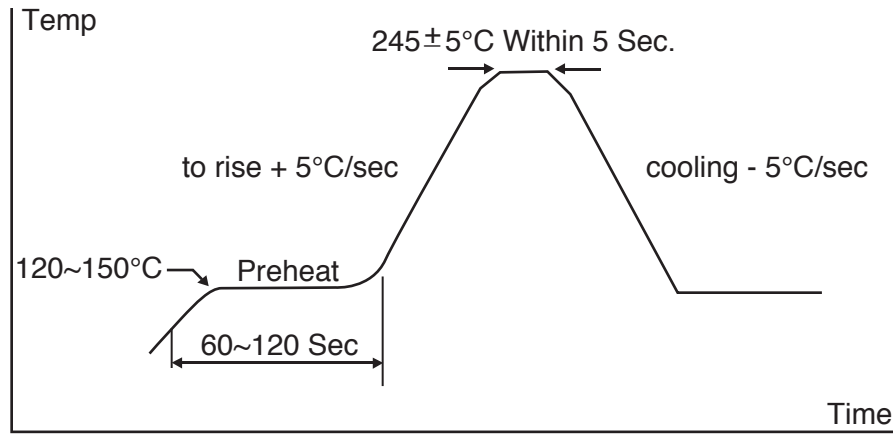

Compliances and Approvals



Looking for pricing, stock, or lifecycle information?

Click below to explore more details on WIN SOURCE:

- [⊖ View LTH3MM12VFR4500 on WIN SOURCE](#)
- [⊖ Visual Communications Company - VCC Information](#)

Optimize Your Supply Chain with WIN SOURCE Solutions

- ✓ Global Sourcing Solution
- ✓ Obsolete Management
- ✓ Cost Control Management
- ✓ Shortage Management
- ✓ Alternative Solution
- ✓ Excess Inventory Management