

## Switch-Dimmable LED Driver

### Features

- Four-level Switch Dimming
- Highly Accurate Current Regulator
- Output Overcurrent or Short-circuit Protection
- IC Overtemperature Protection

### Applications

- Switch-dimmable LED Bulbs and Fixtures

### General Description

The HV9801A LED driver is ideally suited for switch-dimmable applications using LED bulbs and fixtures.

Through switch dimming, the lamp can be adjusted to four discrete brightness levels by rapid cycling of the light switch. The brightness levels are traversed in an up-and-down manner. Brightness resumes at the highest level when power is removed for more than a second.

The device can be powered directly from rectified AC through an internal  $V_{DD}$  regulator rated at 450V.

### Package Types

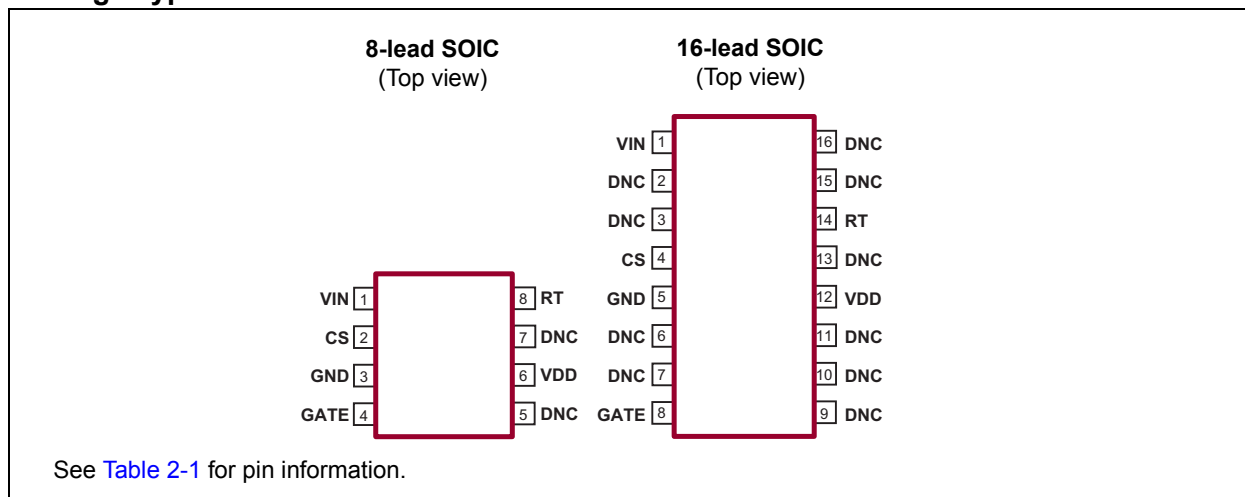

# HV9801A

## Functional Block Diagram

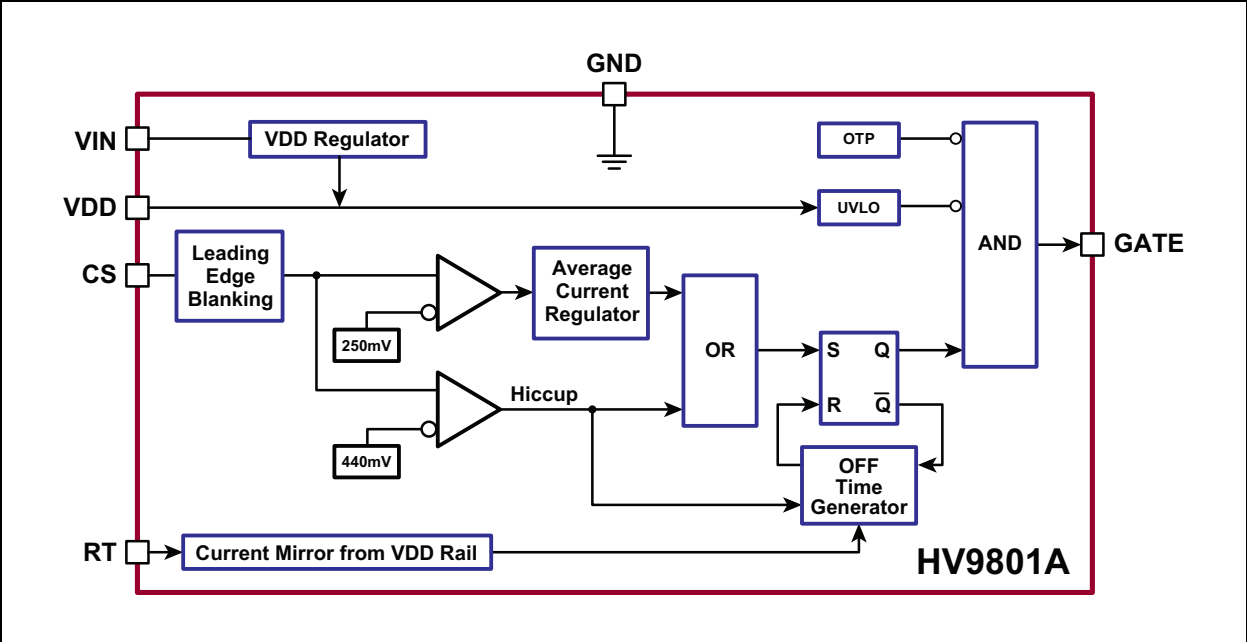

## Typical Application Circuit

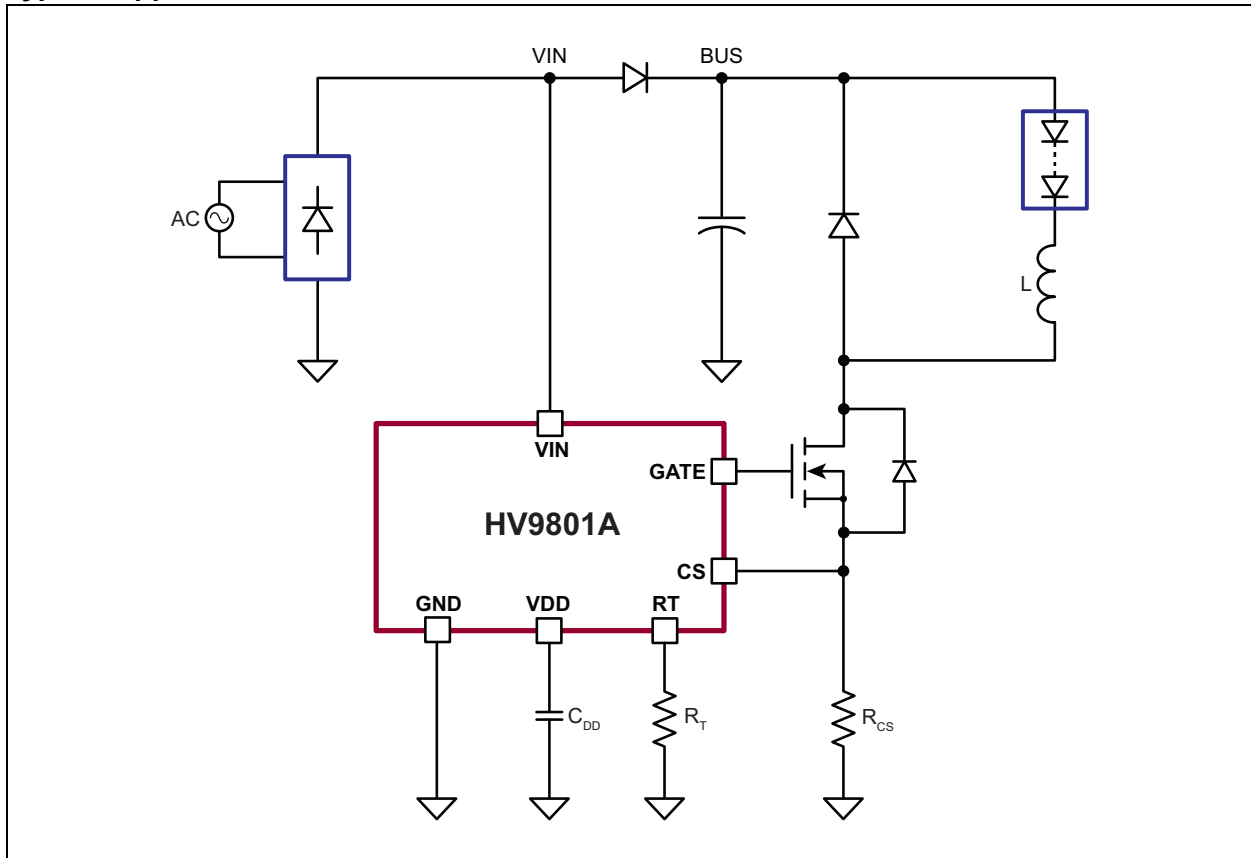

# HV9801A

## 1.0 ELECTRICAL CHARACTERISTICS

### Absolute Maximum Ratings†

$V_{IN}$ .....	470V
$V_{DD}$ .....	12V
$V_{CS}, V_{GATE}$ .....	-0.3V to ( $V_{DD} + 0.3V$ )
Junction Temperature Range, $T_J$ .....	-40°C to +150°C
Storage Temperature Range, $T_S$ .....	-65°C to +150°C
Power Dissipation ( $T_A = 25^\circ C$ ):	
8-lead SOIC .....	650 mW
16-lead SOIC .....	1000 mW

† **Notice:** Stresses above those listed under “Absolute Maximum Ratings” may cause permanent damage to the device. This is a stress rating only, and functional operation of the device at those or any other conditions above those indicated in the operational sections of this specification is not intended. Exposure to maximum rating conditions for extended periods may affect device reliability.

## ELECTRICAL CHARACTERISTICS

Electrical Specifications: Specifications are at $T_A = 25^\circ C$ , $V_{IN} = 15V$ unless otherwise noted.						
Parameter	Sym.	Min.	Typ.	Max.	Unit	Conditions
<b>INPUT</b>						
Input Voltage	$V_{IN}$	15	—	450	V	Note 2
Input Current	$I_{IN}$	—	1	2	mA	
Supply Current, OTP Shutdown	$I_{IN, OT}$	—	—	500	$\mu A$	Note 1
<b><math>V_{DD}</math> REGULATOR</b>						
Undervoltage Lockout Threshold	$V_{UVLO}$	6.45	6.7	7.1	V	$V_{IN}$ rising (Note 2)
Undervoltage Lockout Hysteresis	$\Delta V_{UVLO}$	—	500	—	mV	$V_{IN}$ falling
Maximum Input Current, Limited by UVLO	$I_{UVLO}$	3.5	—	—	mA	$T_A = 25^\circ C$ (Note 1)
		1.5	—	—	mA	$T_A = 125^\circ C$ (Note 1)
Output Voltage	$V_{DD}$	7.25	7.5	7.75	V	$C_{GATE} = 500$ pF, $R_T = 226$ k $\Omega$
Line Regulation	$\Delta V_{DD, LINE}$	—	—	1	V	$V_{IN} = 15V$ to 450V, $C_{GATE} = 500$ pF, $R_T = 226$ k $\Omega$
$V_{DD}$ Voltage Margin	$\Delta V_{DD(UV)}$	500	—	—	mV	$\Delta V_{DD(UV)} = V_{DD} - V_{UVLO}$ , FALL (Note 2)
Load Regulation	$\Delta V_{DD, LOAD}$	—	—	100	mV	$I_{VDD} = 0$ mA to 1 mA, $C_{GATE} = 500$ pF, $R_T = 226$ k $\Omega$
<b>SWITCH DIMMING</b>						
Supply Current after Power Loss	$I_{VDDX}$	—	—	700	$\mu A$	Note 2
Undervoltage Lockout during $V_{IN}$ Power Loss	$V_{UVLO, DIM}$	—	3.5	—	V	$V_{IN}$ falling
Power Loss, Qualification Time	$T_{PL1}$	—	60	—	ms	$V_{IN}$ falling below $V_{UVLO}$ (Note 1)
Power Loss, Time to Reset	$T_{PL2}$	—	1	—	s	
PWM Dimming Frequency	$F_{PWM}$	—	1.2	—	kHz	
<b>LED CURRENT REGULATOR</b>						
Current Sense Threshold	$V_{CST}$	236	250	256	mV	Note 2

**Note 1:** Determined by characterization; not production tested

**2:** Specifications apply over the full operating ambient temperature range of  $-40^\circ C < T_A < +125^\circ C$ .

## ELECTRICAL CHARACTERISTICS (CONTINUED)

Electrical Specifications: Specifications are at $T_A = 25^\circ\text{C}$ , $V_{IN} = 15\text{V}$ unless otherwise noted.						
Parameter	Sym.	Min.	Typ.	Max.	Unit	Conditions
Leading Edge Blanking Time	$T_{LEB}$	110	—	260	ns	Note 2
Minimum On-time	$T_{ONX}$	—	—	760	ns	$V_{CS} = V_{CST} + 30\text{ mV}$
Maximum Duty Cycle Maintaining Regulation	$D_{MAX}$	80	—	—	%	LED current falls beyond this duty cycle
<b>SHORT-CIRCUIT PROTECTION</b>						
Hiccup Threshold	$V_{CSH}$	—	440	—	mV	
$V_{CS}$ High to Gate Low Delay	$T_{DLY}$	—	—	180	ns	$V_{CS} = V_{CSH} + 30\text{ mV}$
Hiccup Time	$T_{SCH}$	—	750	—	$\mu\text{s}$	
Minimum On-time	$T_{ONXSC}$	—	—	430	ns	$V_{CS} = V_{DD}$
<b>T<sub>OFF</sub> TIMER</b>						
Off-time	$T_{OFF}$	32	40	48	$\mu\text{s}$	$R_T = 1\text{ M}\Omega$
		8	10	12		$R_T = 226\text{ k}\Omega$
<b>GATE DRIVER</b>						
Sourcing Current	$I_{SRC}$	165	—	—	mA	$V_{GATE} = 0\text{V}$
Sinking Current	$I_{SINK}$	165	—	—	mA	$V_{GATE} = V_{DD}$
Rise Time	$t_r$	—	30	50	ns	$C_{GATE} = 500\text{ pF}$
Fall Time	$t_f$	—	30	50	ns	$C_{GATE} = 500\text{ pF}$
<b>OVERTEMPERATURE PROTECTION</b>						
Trip Temperature	$T_{TRIP}$	—	140	—	$^\circ\text{C}$	Note 1
Hysteresis	$\Delta T_{TRIP}$	—	20	—	$^\circ\text{C}$	Note 1

**Note 1:** Determined by characterization; not production tested

**2:** Specifications apply over the full operating ambient temperature range of  $-40^\circ\text{C} < T_A < +125^\circ\text{C}$ .

## TEMPERATURE SPECIFICATIONS

Parameter	Sym.	Min.	Typ.	Max.	Unit	Conditions
<b>TEMPERATURE RANGE</b>						
Operating Ambient Temperature	$T_A$	-40	—	+125	$^\circ\text{C}$	
Maximum Junction Temperature	$T_J$	-40	—	+150	$^\circ\text{C}$	
Storage Temperature	$T_S$	-65	—	+150	$^\circ\text{C}$	
<b>PACKAGE THERMAL RESISTANCE</b>						
8-lead SOIC	$\theta_{JA}$	—	101	—	$^\circ\text{C/W}$	
16-lead SOIC	$\theta_{JA}$	—	83	—	$^\circ\text{C/W}$	

# HV9801A

## 2.0 PIN DESCRIPTION

The details on the pins of HV9801A are listed on [Table 2-1](#). See location of pins in [Package Types](#).

**TABLE 2-1: PIN FUNCTION TABLE**

Pin Name	8-lead SOIC Pin Number	16-lead SOIC Pin Number	Description
VIN	1	1	Connect to bridge rectifier output. Supplies power to the $V_{DD}$ regulator. Detects light switch power-off event through loss of bridge rectifier output voltage. Do not connect excessive capacitance before or after the bridge to allow $V_{IN}$ to drop rapidly after loss of power.
CS	2	4	Current sense input
GND	3	5	Ground
GATE	4	8	Gate driver output
VDD	6	12	$V_{DD}$ regulator output. Connect a high-frequency bypass and a hold-up capacitor at $V_{DD}$ . Bypass capacitor to be 100 nF minimum. See <a href="#">Section 3.0 “Application Information”</a> for hold-up capacitance.
RT	8	14	Off-time programming input. Connect programming resistor to GND.
DNC	5, 7	2, 3, 6, 7, 9, 10, 11, 13, 15, 16	Stands for “Do Not Connect.”

## 3.0 APPLICATION INFORMATION

### 3.1 Current Control

#### 3.1.1 CONTINUOUS CONDUCTION MODE (CCM)

The HV9801A is designed to control a buck converter operating in CCM.

Continuous Conduction Mode operation is characterized by converter operation with non-zero inductor current throughout the switching cycle. Such operation can be achieved by proper selection of the inductance.

#### 3.1.2 LED CURRENT

The HV9801A regulates the LED current with an accuracy far superior to that of competing Peak Current mode controllers.

Average LED current is set by the current sense resistor  $R_{CS}$  and the current regulator reference voltage. See [Equation 3-1](#) and [Equation 3-2](#).

#### EQUATION 3-1:

$$V = I \times R$$

#### EQUATION 3-2:

$$250mV = I_{LED} \times R_{CS}$$

For example, a 2Ω resistor corresponds to a 125 mA (average) LED current.

#### 3.1.3 CURRENT CONTROL PERFORMANCE

The control method of the HV9801A virtually eliminates the regulation errors associated with Peak Current mode controllers, such as errors caused by inductor tolerance, propagation delay of the current sense comparator, tolerance in the oscillator frequency or off-timer and changes in line and load voltage.

[Figure 3-1](#) compares the load regulation of the HV9801A and that of a device with peak current control. The graph clearly shows the difference in load regulation between the HV9801A and the HV9910B, which is a peak current regulator.

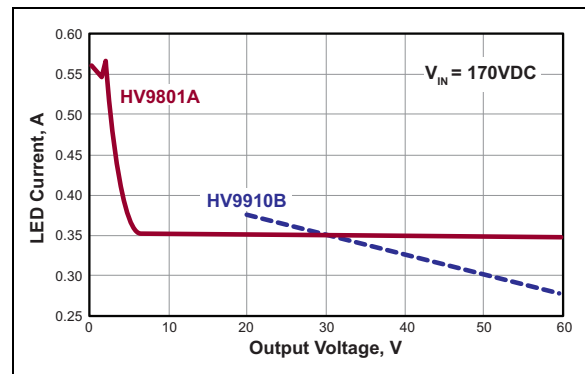

**FIGURE 3-1:** Output Characteristics of the HV9801A LED Driver.

### 3.2 Duty Cycle, Off-time, On-time and Inductor

#### 3.2.1 DUTY CYCLE

The duty cycle (D) is related to the load voltage ( $V_{LED}$ ) and input voltage ( $V_{BUS}$ ) by the simple relation shown in [Equation 3-3](#) and [Equation 3-4](#).

#### EQUATION 3-3:

$$V_{OUT} = D \times V_{IN}$$

#### EQUATION 3-4:

$$V_{LED} = D \times V_{BUS}$$

#### 3.2.2 OFF-TIME

The HV9801A operates with constant off-time control, which avoids subharmonic oscillation.

Switching period and switching frequency are related to on-time and off-time as shown in [Equation 3-5](#) and [Equation 3-6](#).

#### EQUATION 3-5:

$$T_{SW} = T_{ON} + T_{OFF}$$

#### EQUATION 3-6:

$$F_{SW} = \frac{1}{T_{SW}}$$

# HV9801A

On-time is related to off-time and duty cycle. See [Equation 3-7](#).

## EQUATION 3-7:

$$D = \frac{T_{ON}}{(T_{ON} + T_{OFF})}$$

$$T_{ON} = [D / (1 - D)] \times T_{OFF}$$

With a given  $T_{OFF}$ , the HV9801A dynamically adjusts  $T_{ON}$  to regulate the LED current. Specifically,  $T_{ON}$  adapts to the duty cycle associated with the given  $V_{BUS}$  and  $V_{LED}$ .

### 3.2.3 OFF-TIME PROGRAMMING

Off-time is programmed by the  $R_T$  resistor as illustrated in [Equation 3-8](#).

## EQUATION 3-8:

$$T_{OFF} = (A \times R_T) + B$$

Where:  $A = 40 \text{ ps} / \Omega$  and  $B = 300 \text{ ns}$

For instance, a 200 k $\Omega$  resistor corresponds to 8.3  $\mu\text{s}$  off-time.

An acceptable range for  $R_T$  is 30 k $\Omega$  to 1 M $\Omega$ , corresponding to an off-time range between 1.5  $\mu\text{s}$  and 40.3  $\mu\text{s}$ .

### 3.2.4 INDUCTOR

Because the converter should operate in CCM, the inductor current should not fall to zero within a switching cycle and the inductor current ripple should be sized accordingly.

A common choice for peak-to-peak inductor current ripple (PPR) is 30% to 40% of nominal LED current.

Inductance can be calculated from the current drop during off-time as shown in [Equation 3-9](#) and [Equation 3-10](#).

## EQUATION 3-9:

$$L \times \Delta I = V \times \Delta T$$

## EQUATION 3-10:

$$L \times PPR \times I_{LED} = V_{LED} \times T_{OFF}$$

For example, 30% PPR on 350 mA average current equates to 105 mA ripple, which together with 5  $\mu\text{s}$  off-time and 30V LED string voltage corresponds to 1.43 mH inductance.

A design with 30V LED voltage and 150V bus voltage corresponds to a 20% duty cycle, while a 120V bus voltage coincides with a 25% duty cycle. A 20% duty cycle corresponds to 1.25  $\mu\text{s}$  on-time, and a 25% duty

cycle corresponds to 1.67  $\mu\text{s}$  on-time. Hence, the switching frequency is 160 kHz at 150V bus voltage and 150 kHz at 120V bus voltage.

### 3.2.5 MAXIMUM DUTY CYCLE

Duty cycle should be limited to the specified maximum of 80%. Accordingly, the targeted LED string voltage and the bus voltage are limited to the same ratio. Operation at a larger desired duty cycle than the maximum duty cycle results in an LED current lower than programmed.

### 3.2.6 MINIMUM DUTY CYCLE

Duty cycle is limited on the low side by the minimum on-time specification (760 ns). Operation at a smaller desired on-time than the minimum causes the LED current to exceed the programmed value.

LED string voltage cannot be made arbitrarily low. Minimum LED string voltage can be determined with [Equation 3-11](#).

## EQUATION 3-11:

$$D_{MIN} = \frac{T_{ONX}}{(T_{OFF} + T_{ONX})}$$

$$V_{LED} = D_{MIN} \times V_{BUS}$$

For instance, with 5  $\mu\text{s}$  off-time, the duty cycle should be kept above 13%. Such a duty cycle corresponds to an LED string voltage of 19.5V at 150V bus voltage.

A design that needs a lower LED string voltage requires a longer off-time.

### 3.2.7 SHORT-CIRCUIT PROTECTION

An increase in the LED current sense signal above 440 mV (176% of nominal) trips the short-circuit comparator, thereby causing the converter to switch to Hiccup mode. In Hiccup mode, off-time is lengthened to about 750  $\mu\text{s}$  to allow the inductor current to drop to a safe level.

Without the extended off-time, the inductor current increases with every switching cycle, causing an overcurrent damage to the converter.

The off-time extension can be observed in [Figure 3-2](#) below.

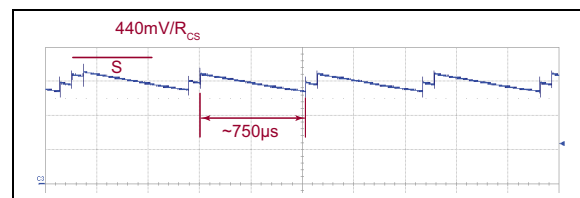

**FIGURE 3-2:** Short-circuit Inductor Current.

## 3.2.8 LEADING EDGE BLANKING

The MOSFET drain current and the current sense signal exhibit a spike at the start of a switching cycle, which arises from the MOSFET gate charging current and the current required for discharging the MOSFET drain node. These two currents typically exceed the inductor by quite a margin.

The current sense signal is blanked at the start of the switching cycle in order to avoid a premature trigger of the current sense and the short-circuit protection comparators.

## 3.2.9 $V_{DD}$ REGULATOR

The  $V_{DD}$  regulator generates a source of regulated voltage for operation of internal and external circuits from the power applied at the  $V_{IN}$  pin. Alternatively, the  $V_{DD}$  voltage can be supplied from a source directly connected to the  $V_{DD}$  pin.

## 3.3 Switch Dimming

### 3.3.1 GENERAL

Lamp brightness can be adjusted to one of four discrete levels by rapidly cycling power with the light switch. The brightness levels are traversed in an up-and-down manner, the four levels being 100%, 50%, 25% and 12.5%. Brightness resumes at the highest level when power is removed for more than a second.

Reduction of LED current is accomplished through PWM dimming with a PWM dimming frequency of about 1 kHz. The PWM frequency is generated by an internal oscillator, and the PWM duty cycle is controlled by digital logic.

Turning the light switch off and on within one second adjusts LED current to the next level in each dimming step. The direction of dimming depends on the existing position in the dimming sequence. The illustration in [Figure 3-3](#) shows more details. The sequence starts at 100% and adjusts to the next lower level by the first dimming step and then adjusts to the next lower level by the next dimming step. Upon reaching the lowest or highest level, the direction of the sequence reverses. Therefore, the actual overall dimming sequence is 100%, 50%, 25%, 12.5%, 25%, 50%, 100%, and the sequence repeats as the dimming steps continue. When power is removed for more than one second, the dimming sequence is terminated and the brightness is reset to 100% upon turn-on of the light switch.

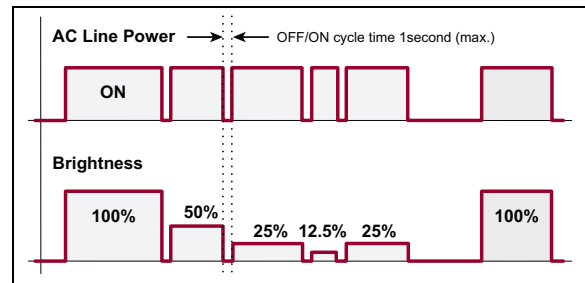

**FIGURE 3-3:** LED Brightness and AC Line Power.

### 3.3.2 $V_{DD}$ CAPACITOR

The  $V_{DD}$  voltage should be maintained for at least one second and above the 3.5V level after loss of  $V_{IN}$  power to allow certain timing circuits to function.

The minimum  $V_{DD}$  capacitance required can be calculated with [Equation 3-12](#).

#### EQUATION 3-12:

$$C \times \Delta V = I \times \Delta T$$

$$C_{DD} \times (7.5V - 3.5V) = I_{VDDX} \times 1s$$

With 700  $\mu$ A of  $I_{VDDX}$  the bypass capacitance should be 175  $\mu$ F.

### 3.3.3 DETECTION OF POWER CYCLING

The presence of AC line power is detected at the  $V_{IN}$  pin. To this end, loss of AC power should result in a rapidly falling voltage at the output of the bridge rectifier.

The  $V_{IN}$  voltage drops due to the current draw from the  $V_{DD}$  regulator. In order to facilitate a quick drop in voltage, a diode should be added to isolate the bus capacitor from the  $V_{IN}$  pin as shown in the [Typical Application Circuit](#).

# HV9801A

## 4.0 PACKAGING INFORMATION

### 4.1 Package Marking Information

8-lead SOIC

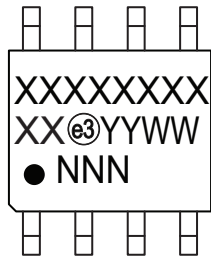

Example

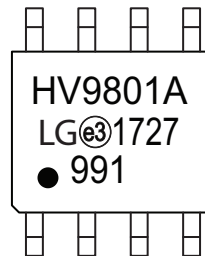

16-lead SOIC

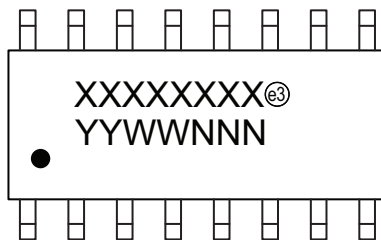

Example



<b>Legend:</b>	XX...X	Product Code or Customer-specific information
	Y	Year code (last digit of calendar year)
	YY	Year code (last 2 digits of calendar year)
	WW	Week code (week of January 1 is week '01')
	NNN	Alphanumeric traceability code
	(e3)	Pb-free JEDEC <sup>®</sup> designator for Matte Tin (Sn)
	*	This package is Pb-free. The Pb-free JEDEC designator (e3) can be found on the outer packaging for this package.
<b>Note:</b>	In the event the full Microchip part number cannot be marked on one line, it will be carried over to the next line, thus limiting the number of available characters for product code or customer-specific information. Package may or not include the corporate logo.	

## 8-Lead SOIC (Narrow Body) Package Outline (LG/TG) 4.90x3.90mm body, 1.75mm height (max), 1.27mm pitch

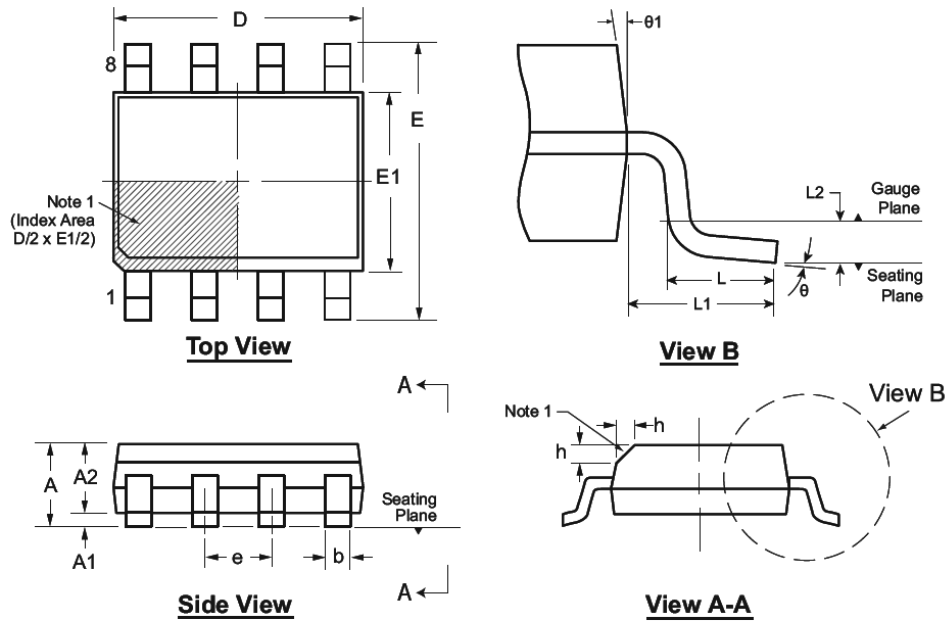

Note: For the most current package drawings, see the Microchip Packaging Specification at [www.microchip.com/packaging](http://www.microchip.com/packaging).

**Note:**

- This chamfer feature is optional. A Pin 1 identifier must be located in the index area indicated. The Pin 1 identifier can be: a molded mark/identifier, an embedded metal marker, or a printed indicator.

Symbol	A	A1	A2	b	D	E	E1	e	h	L	L1	L2	$\theta$	$\theta 1$	
Dimension (mm)	MIN	1.35*	0.10	1.25	0.31	4.80*	5.80*	3.80*	1.27 BSC	0.25	0.40	1.04 REF	0.25 BSC	0°	5°
	NOM	-	-	-	-	4.90	6.00	3.90		-	-			-	-
	MAX	1.75	0.25	1.65*	0.51	5.00*	6.20*	4.00*		0.50	1.27			8°	15°

JEDEC Registration MS-012, Variation AA, Issue E, Sept. 2005.

\* This dimension is not specified in the JEDEC drawing.

Drawings are not to scale.

# HV9801A

## 16-Lead SOIC (Narrow Body) Package Outline (NG) 9.90x3.90mm body, 1.75mm height (max), 1.27mm pitch

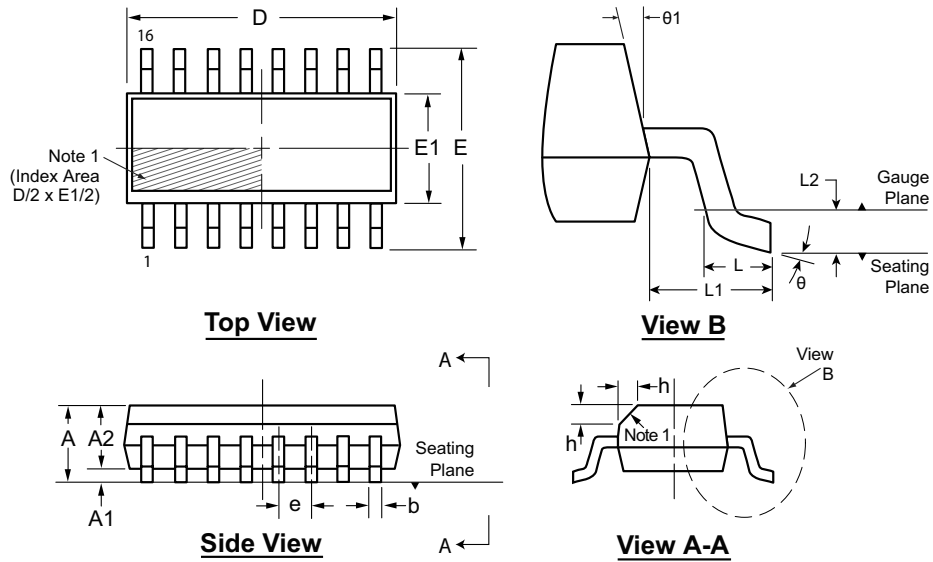

Note: For the most current package drawings, see the Microchip Packaging Specification at [www.microchip.com/packaging](http://www.microchip.com/packaging).

**Note:**

1. This chamfer feature is optional. If it is not present, then a Pin 1 identifier must be located in the index area indicated. The Pin 1 identifier can be: a molded mark/identifier; an embedded metal marker; or a printed indicator.

Symbol	A	A1	A2	b	D	E	E1	e	h	L	L1	L2	$\theta$	$\theta 1$
Dimension (mm)	MIN	1.35*	0.10	1.25	0.31	9.80*	5.80*	3.80*	0.25	0.40	1.04 REF	0.25 BSC	0°	5°
	NOM	-	-	-	-	9.90	6.00	3.90	-	-			-	-
	MAX	1.75	0.25	1.65*	0.51	10.00*	6.20*	4.00*	0.50	1.27			8°	15°

JEDEC Registration MS-012, Variation AC, Issue E, Sept. 2005.

\* This dimension is not specified in the JEDEC drawing.

Drawings are not to scale.

## APPENDIX A: REVISION HISTORY

### Revision A (September 2017)

- Converted Supertex Doc# DSFP-HV9801A to Microchip DS20005692A
- Updated the part marking format
- Removed the 16-lead SOIC Narrow (NG) M934 media type
- Changed the quantity of the 8-lead SOIC (Narrow) LG package from 2500/Reel to 3300/Reel
- Made minor text changes throughout the document

# HV9801A

## PRODUCT IDENTIFICATION SYSTEM

To order or obtain information, e.g., on pricing or delivery, contact your local Microchip representative or sales office.

<u>PART NO.</u>	<u>XX</u>	-	<u>X</u>	-	<u>X</u>
Device	Package Options		Environmental		Media Type
Device:	HV9801A	=	Switch-Dimmable LED Driver		
Packages:	LG	=	8-lead SOIC		
	NG	=	16-lead SOIC		
Environmental:	G	=	Lead (Pb)-free/RoHS-compliant Package		
Media Type:	(blank)	=	3300/Reel for an LG Package		
		=	45/Tube for an NG Package		

**Examples:**

- a) HV9801ALG-G: Switch-Dimmable LED Driver, 8-lead SOIC Package, 3300/Reel
- b) HV9801ANG-G: Switch-Dimmable LED Driver, 16-lead SOIC Package, 45/Tube

---

---

**Note the following details of the code protection feature on Microchip devices:**

- Microchip products meet the specification contained in their particular Microchip Data Sheet.
- Microchip believes that its family of products is one of the most secure families of its kind on the market today, when used in the intended manner and under normal conditions.
- There are dishonest and possibly illegal methods used to breach the code protection feature. All of these methods, to our knowledge, require using the Microchip products in a manner outside the operating specifications contained in Microchip's Data Sheets. Most likely, the person doing so is engaged in theft of intellectual property.
- Microchip is willing to work with the customer who is concerned about the integrity of their code.
- Neither Microchip nor any other semiconductor manufacturer can guarantee the security of their code. Code protection does not mean that we are guaranteeing the product as “unbreakable.”

Code protection is constantly evolving. We at Microchip are committed to continuously improving the code protection features of our products. Attempts to break Microchip's code protection feature may be a violation of the Digital Millennium Copyright Act. If such acts allow unauthorized access to your software or other copyrighted work, you may have a right to sue for relief under that Act.

---

Information contained in this publication regarding device applications and the like is provided only for your convenience and may be superseded by updates. It is your responsibility to ensure that your application meets with your specifications. MICROCHIP MAKES NO REPRESENTATIONS OR WARRANTIES OF ANY KIND WHETHER EXPRESS OR IMPLIED, WRITTEN OR ORAL, STATUTORY OR OTHERWISE, RELATED TO THE INFORMATION, INCLUDING BUT NOT LIMITED TO ITS CONDITION, QUALITY, PERFORMANCE, MERCHANTABILITY OR FITNESS FOR PURPOSE. Microchip disclaims all liability arising from this information and its use. Use of Microchip devices in life support and/or safety applications is entirely at the buyer's risk, and the buyer agrees to defend, indemnify and hold harmless Microchip from any and all damages, claims, suits, or expenses resulting from such use. No licenses are conveyed, implicitly or otherwise, under any Microchip intellectual property rights unless otherwise stated.

*Microchip received ISO/TS-16949:2009 certification for its worldwide headquarters, design and wafer fabrication facilities in Chandler and Tempe, Arizona; Gresham, Oregon and design centers in California and India. The Company's quality system processes and procedures are for its PIC® MCUs and dsPIC® DSCs, KEELOQ® code hopping devices, Serial EEPROMs, microperipherals, nonvolatile memory and analog products. In addition, Microchip's quality system for the design and manufacture of development systems is ISO 9001:2000 certified.*

**QUALITY MANAGEMENT SYSTEM  
CERTIFIED BY DNV  
= ISO/TS 16949 =**

### Trademarks

The Microchip name and logo, the Microchip logo, AnyRate, AVR, AVR logo, AVR Freaks, BeaconThings, BitCloud, CryptoMemory, CryptoRF, dsPIC, FlashFlex, flexPWR, Helder, JukeBlox, KEELOQ, KEELOQ logo, Klear, LANCheck, LINK MD, maXStylus, maXTouch, MediaLB, megaAVR, MOST, MOST logo, MPLAB, OptoLyzer, PIC, picoPower, PICSTART, PIC32 logo, Prochip Designer, QTouch, RightTouch, SAM-BA, SpyNIC, SST, SST Logo, SuperFlash, tinyAVR, UNI/O, and XMEGA are registered trademarks of Microchip Technology Incorporated in the U.S.A. and other countries.

ClockWorks, The Embedded Control Solutions Company, EtherSynch, Hyper Speed Control, HyperLight Load, IntelliMOS, mTouch, Precision Edge, and Quiet-Wire are registered trademarks of Microchip Technology Incorporated in the U.S.A.

Adjacent Key Suppression, AKS, Analog-for-the-Digital Age, Any Capacitor, AnyIn, AnyOut, BodyCom, chipKIT, chipKIT logo, CodeGuard, CryptoAuthentication, CryptoCompanion, CryptoController, dsPICDEM, dsPICDEM.net, Dynamic Average Matching, DAM, ECAN, EtherGREEN, In-Circuit Serial Programming, ICSP, Inter-Chip Connectivity, JitterBlocker, KlearNet, KlearNet logo, Mindi, MiWi, motorBench, MPASM, MPF, MPLAB Certified logo, MPLIB, MPLINK, MultiTRAK, NetDetach, Omniscient Code Generation, PICDEM, PICDEM.net, PICKit, PICtail, PureSilicon, QMatrix, RightTouch logo, REAL ICE, Ripple Blocker, SAM-ICE, Serial Quad I/O, SMART-I.S., SQI, SuperSwitcher, SuperSwitcher II, Total Endurance, TSHARC, USBCheck, VariSense, ViewSpan, WiperLock, Wireless DNA, and ZENA are trademarks of Microchip Technology Incorporated in the U.S.A. and other countries.

SQTP is a service mark of Microchip Technology Incorporated in the U.S.A.

Silicon Storage Technology is a registered trademark of Microchip Technology Inc. in other countries.

GestIC is a registered trademark of Microchip Technology Germany II GmbH & Co. KG, a subsidiary of Microchip Technology Inc., in other countries.

All other trademarks mentioned herein are property of their respective companies.

© 2017, Microchip Technology Incorporated, All Rights Reserved.  
ISBN: 978-1-5224-2134-4



# MICROCHIP

## Worldwide Sales and Service

### AMERICAS

**Corporate Office**  
2355 West Chandler Blvd.  
Chandler, AZ 85224-6199  
Tel: 480-792-7200  
Fax: 480-792-7277  
Technical Support:  
<http://www.microchip.com/support>  
Web Address:  
[www.microchip.com](http://www.microchip.com)

**Atlanta**  
Duluth, GA  
Tel: 678-957-9614  
Fax: 678-957-1455

**Austin, TX**  
Tel: 512-257-3370

**Boston**  
Westborough, MA  
Tel: 774-760-0087  
Fax: 774-760-0088

**Chicago**  
Itasca, IL  
Tel: 630-285-0071  
Fax: 630-285-0075

**Dallas**  
Addison, TX  
Tel: 972-818-7423  
Fax: 972-818-2924

**Detroit**  
Novi, MI  
Tel: 248-848-4000

**Houston, TX**  
Tel: 281-894-5983

**Indianapolis**  
Noblesville, IN  
Tel: 317-773-8323  
Fax: 317-773-5453  
Tel: 317-536-2380

**Los Angeles**  
Mission Viejo, CA  
Tel: 949-462-9523  
Fax: 949-462-9608  
Tel: 951-273-7800

**Raleigh, NC**  
Tel: 919-844-7510

**New York, NY**  
Tel: 631-435-6000

**San Jose, CA**  
Tel: 408-735-9110  
Tel: 408-436-4270

**Canada - Toronto**  
Tel: 905-695-1980  
Fax: 905-695-2078

### ASIA/PACIFIC

**Asia Pacific Office**  
Suites 3707-14, 37th Floor  
Tower 6, The Gateway  
Harbour City, Kowloon

**Hong Kong**  
Tel: 852-2943-5100  
Fax: 852-2401-3431

**Australia - Sydney**  
Tel: 61-2-9868-6733  
Fax: 61-2-9868-6755

**China - Beijing**  
Tel: 86-10-8569-7000  
Fax: 86-10-8528-2104

**China - Chengdu**  
Tel: 86-28-8665-5511  
Fax: 86-28-8665-7889

**China - Chongqing**  
Tel: 86-23-8980-9588  
Fax: 86-23-8980-9500

**China - Dongguan**  
Tel: 86-769-8702-9880

**China - Guangzhou**  
Tel: 86-20-8755-8029

**China - Hangzhou**  
Tel: 86-571-8792-8115  
Fax: 86-571-8792-8116

**China - Hong Kong SAR**  
Tel: 852-2943-5100  
Fax: 852-2401-3431

**China - Nanjing**  
Tel: 86-25-8473-2460  
Fax: 86-25-8473-2470

**China - Qingdao**  
Tel: 86-532-8502-7355  
Fax: 86-532-8502-7205

**China - Shanghai**  
Tel: 86-21-3326-8000  
Fax: 86-21-3326-8021

**China - Shenyang**  
Tel: 86-24-2334-2829  
Fax: 86-24-2334-2393

**China - Shenzhen**  
Tel: 86-755-8864-2200  
Fax: 86-755-8203-1760

**China - Wuhan**  
Tel: 86-27-5980-5300  
Fax: 86-27-5980-5118

**China - Xian**  
Tel: 86-29-8833-7252  
Fax: 86-29-8833-7256

### ASIA/PACIFIC

**China - Xiamen**  
Tel: 86-592-2388138  
Fax: 86-592-2388130

**China - Zhuhai**  
Tel: 86-756-3210040  
Fax: 86-756-3210049

**India - Bangalore**  
Tel: 91-80-3090-4444  
Fax: 91-80-3090-4123

**India - New Delhi**  
Tel: 91-11-4160-8631  
Fax: 91-11-4160-8632

**India - Pune**  
Tel: 91-20-3019-1500

**Japan - Osaka**  
Tel: 81-6-6152-7160  
Fax: 81-6-6152-9310

**Japan - Tokyo**  
Tel: 81-3-6880-3770  
Fax: 81-3-6880-3771

**Korea - Daegu**  
Tel: 82-53-744-4301  
Fax: 82-53-744-4302

**Korea - Seoul**  
Tel: 82-2-554-7200  
Fax: 82-2-558-5932 or  
82-2-558-5934

**Malaysia - Kuala Lumpur**  
Tel: 60-3-6201-9857  
Fax: 60-3-6201-9859

**Malaysia - Penang**  
Tel: 60-4-227-8870  
Fax: 60-4-227-4068

**Philippines - Manila**  
Tel: 63-2-634-9065  
Fax: 63-2-634-9069

**Singapore**  
Tel: 65-6334-8870  
Fax: 65-6334-8850

**Taiwan - Hsin Chu**  
Tel: 886-3-5778-366  
Fax: 886-3-5770-955

**Taiwan - Kaohsiung**  
Tel: 886-7-213-7830

**Taiwan - Taipei**  
Tel: 886-2-2508-8600  
Fax: 886-2-2508-0102

**Thailand - Bangkok**  
Tel: 66-2-694-1351  
Fax: 66-2-694-1350

### EUROPE

**Austria - Wels**  
Tel: 43-7242-2244-39  
Fax: 43-7242-2244-393

**Denmark - Copenhagen**  
Tel: 45-4450-2828  
Fax: 45-4485-2829

**Finland - Espoo**  
Tel: 358-9-4520-820

**France - Paris**  
Tel: 33-1-69-53-63-20  
Fax: 33-1-69-30-90-79

**France - Saint Cloud**  
Tel: 33-1-30-60-70-00

**Germany - Garching**  
Tel: 49-8931-9700

**Germany - Haan**  
Tel: 49-2129-3766400

**Germany - Heilbronn**  
Tel: 49-7131-67-3636

**Germany - Karlsruhe**  
Tel: 49-721-625370

**Germany - Munich**  
Tel: 49-89-627-144-0  
Fax: 49-89-627-144-44

**Germany - Rosenheim**  
Tel: 49-8031-354-560

**Israel - Ra'anana**  
Tel: 972-9-744-7705

**Italy - Milan**  
Tel: 39-0331-742611  
Fax: 39-0331-466781

**Italy - Padova**  
Tel: 39-049-7625286

**Netherlands - Drunen**  
Tel: 31-416-690399  
Fax: 31-416-690340

**Norway - Trondheim**  
Tel: 47-7289-7561

**Poland - Warsaw**  
Tel: 48-22-3325737

**Romania - Bucharest**  
Tel: 40-21-407-87-50

**Spain - Madrid**  
Tel: 34-91-708-08-90  
Fax: 34-91-708-08-91

**Sweden - Gothenberg**  
Tel: 46-31-704-60-40

**Sweden - Stockholm**  
Tel: 46-8-5090-4654

**UK - Wokingham**  
Tel: 44-118-921-5800  
Fax: 44-118-921-5820

## Looking for pricing, stock, or lifecycle information?

Click below to explore more details on WIN SOURCE:

- ⊖ [View HV9801ALG-G on WIN SOURCE](#)
- ⊖ [Microchip Technology](#) Information

## Optimize Your Supply Chain with WIN SOURCE Solutions

- ✓ Global Sourcing Solution
- ✓ Obsolete Management
- ✓ Cost Control Management
- ✓ Shortage Management
- ✓ Alternative Solution
- ✓ Excess Inventory Management