



**THE DATASHEET OF  
HV430WG-G**



# High-Voltage Ring Generator

## Features

- ▶ 105Vrms ring signal
- ▶ Output overcurrent protection
- ▶ 5.0V CMOS logic control
- ▶ Logic enable/disable to save power
- ▶ Adjustable deadband in single-control mode
- ▶ Power-on reset
- ▶ Fault output for problem detection

## Applications

- ▶ Line access cards
- ▶ Set-top/Street box

The RESET input functions as a power-on reset when connected to an external capacitor. The FAULT output indicates an overcurrent condition and is cleared after 4 consecutive cycles with no overcurrent condition. A logic low on RESET or ENABLE clears the FAULT output. It is active-low and open-drain to allow wire OR'ing of multiple drivers.

$P_{GATE}$  and  $N_{GATE}$  are controlled independently by logic inputs  $P_{IN}$  and  $N_{IN}$  when the MODE pin is at logic high. A logic high on  $P_{IN}$  will turn on the external P-channel MOSFET. Similarly, a logic high on  $N_{IN}$  will turn on the external N-channel MOSFET. Lockout circuitry prevents the N and P switches from turning on simultaneously. A pulse width limiter restricts pulse widths to no less than 100 - 200ns.

## General Description

The Supertex HV430 is a high voltage PWM ring generator integrated circuit. The high voltage outputs,  $V_{PGATE}$  and  $V_{NGATE}$ , are used to drive the gates of external high voltage N-channel and P-channel MOSFETs in a push-pull configuration. Overcurrent protection is implemented for both the P-channel and N-channel MOSFETs. External sense resistors set the over-current trip point.

For applications where a single control input is desired, the MODE pin should be connected to SGND. The PWM control signal is then input to the  $N_{IN}$  pin. A user-adjustable deadband in the control logic ensures break-before-make on the outputs, thus avoiding cross conduction on the high voltage output during switching. A logic high on  $N_{IN}$  will turn the external P-Channel MOSFET on and the N-Channel off, and vice versa. The IC can be powered down by applying a logic low on the ENABLE pin, placing both external MOSFETs in the off state.

## Functional Block Diagram

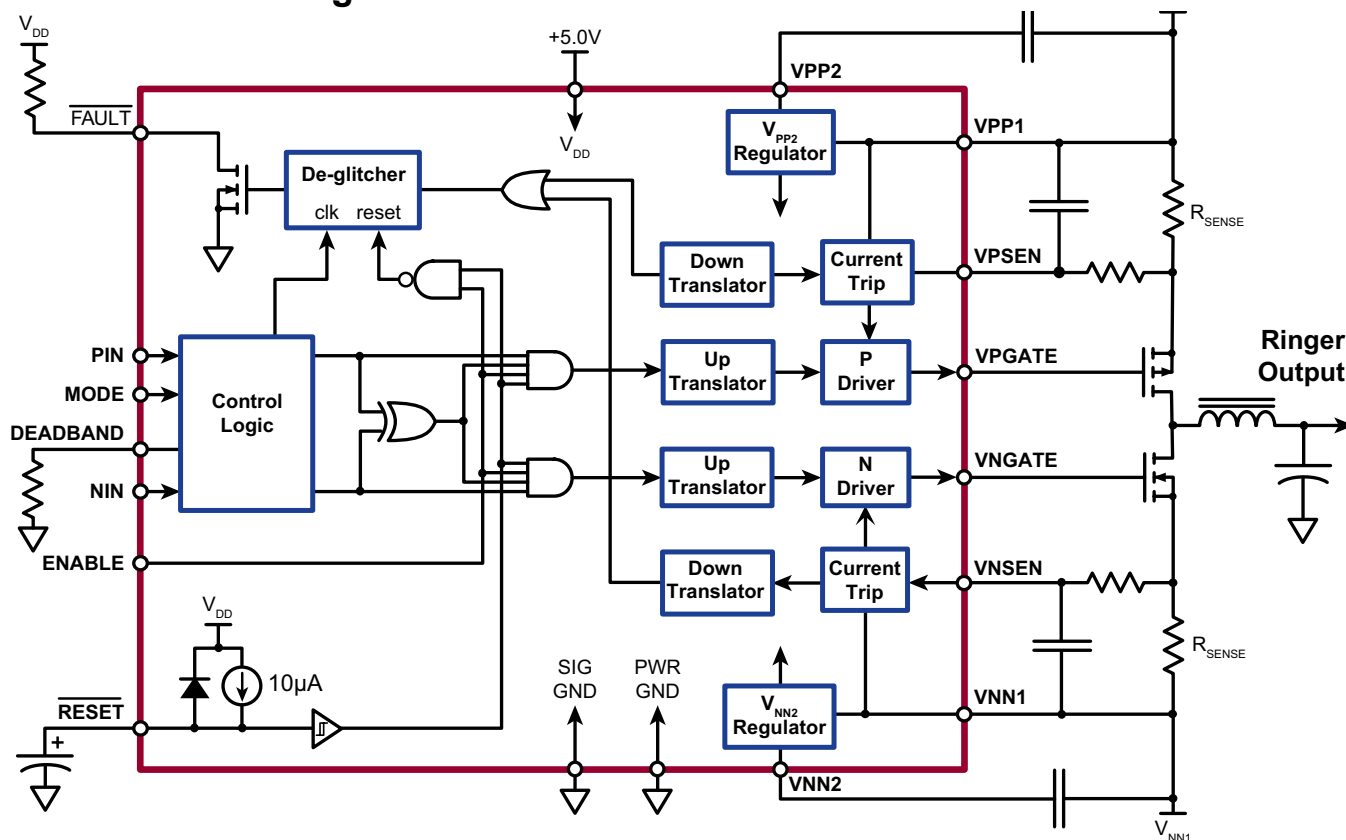

## Ordering Information

Part Number	Package Option	Packing
HV430WG-G	20-Lead SOW	1000/Reel

-G denotes a lead (Pb)-free / RoHS compliant package

## Absolute Maximum Ratings

Parameter	Value
$V_{PP1} - V_{NN1}$ , power supply voltage	+340V
$V_{PP1}$ , positive high voltage supply	+220V
$V_{PP2}$ , positive gate voltage supply	+220V
$V_{NN1}$ , negative high voltage supply	-220V
$V_{NN2}$ , negative gate voltage supply	-220V
$V_{DD}$ , logic supply	+7.5V
Operating temperature range	-40°C to +85°C
Storage temperature range	-65°C to +150°C
Power dissipation	600mW

Stresses beyond those listed under "Absolute Maximum Ratings" may cause permanent damage to the device. These are stress ratings only, and functional operation of the device at these or any other conditions beyond those indicated in the operational sections of the specifications is not implied. Exposure to absolute maximum rating conditions for extended periods may affect device reliability.

## Pin Configuration

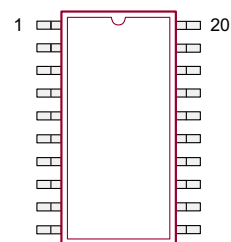

20-Lead SOW  
(top view)

## Product Marking

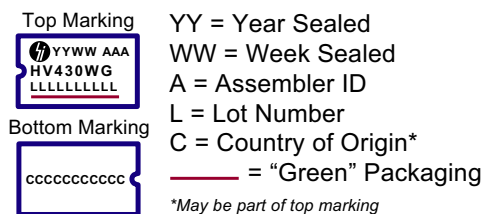

Package may or may not include the following marks: Si or

20-Lead SOW

## Typical Thermal Resistance

Package	$\theta_{ja}$
20-Lead SOW	66°C/W

## Electrical Characteristics (Over operating supply voltage unless otherwise specified. $T_A = -40^\circ\text{C}$ to $+85^\circ\text{C}$ )

Sym	Parameter	Min	Typ	Max	Units	Conditions
$V_{PP1}$	High voltage positive supply	50	-	200	V	---
$I_{PP1Q}$	$V_{PP1}$ quiescent current	-	250	500	$\mu\text{A}$	$P_{IN} = N_{IN} = 0\text{V}$
$I_{PP1}$	$V_{PP1}$ operating current	-	-	2.0	mA	No load, $V_{OUTP}$ and $V_{OUTN}$ switching at 100KHz
$V_{NN1}$	High voltage negative supply	$V_{PP1} - 325$	-	-50	V	---
$I_{NN1Q}$	$V_{NN1}$ quiescent current	-	250	500	$\mu\text{A}$	$P_{IN} = N_{IN} = 0\text{V}$ , $R_{DB} = 18\text{k}\Omega$
$I_{NN1}$	$V_{NN1}$ operating current	-	-	1.0	mA	No load, $V_{OUTP}$ and $V_{OUTN}$ switching at 100KHz
$V_{DD}$	Logic supply voltage	4.50	-	5.50	V	---
$I_{DDQ}$	$V_{DD}$ quiescent current	-	300	400	$\mu\text{A}$	$P_{IN} = N_{IN} = 0\text{V}$ , $R_{DB} = 18\text{k}\Omega$
$I_{DD}$	$V_{DD}$ operating current	-	-	1.0	mA	$P_{IN} = N_{IN} = 100\text{KHz}$ , $R_{DB} = 18\text{k}\Omega$

**Electrical Characteristics (cont.)** (Over operating supply voltage unless otherwise specified.  $T_A = -40^\circ\text{C}$  to  $+85^\circ\text{C}$ )

Sym	Parameter	Min	Typ	Max	Units	Conditions
-----	-----------	-----	-----	-----	-------	------------

**Internal Supplies**

$V_{PP2}$	Positive linear regulator output voltage	$V_{PP1} - 16$	-	$V_{PP1} - 10$	V	---
$V_{NN2}$	Negative linear regulator output voltage	$V_{PP1} + 10$	-	$V_{PP1} + 14$	V	---

**Positive High Voltage Output**

$V_{PGATE}$	Output voltage swing	$V_{PP2}$	-	$V_{PP1}$	V	No load on $V_{PGATE}$
$R_{SOURCEP}$	$V_{PGATE}$ source resistance	-	-	12.5	$\Omega$	$I_{OUT} = 80\text{mA}$
$R_{SINKP}$	$V_{PGATE}$ sink resistance	-	-	12.5	$\Omega$	$I_{OUT} = -80\text{mA}$
$t_{RISEP}$	$V_{PGATE}$ rise time	-	-	50	ns	$C_{LOAD} = 1.4\text{nF}$
$t_{FALLP}$	$V_{PGATE}$ fall time	-	-	50	ns	$C_{LOAD} = 1.4\text{nF}$
$t_{PWP(MIN)}$	$V_{PGATE}$ minimum pulse width (internally limited)	100	150	200	ns	---
$t_{DELAYP}$	$P_{IN}$ to $P_{GATE}$ delay time	-	-	300	ns	Mode = 1
$V_{PSEN}$	$V_{PGATE}$ current sense voltage	$V_{PP1} - 0.85$	$V_{PP1} - 1.0$	$V_{PP1} - 1.15$	V	---
$t_{SHORTP}$	$V_{PGATE}$ current sense off time	-	-	150	ns	---

**Negative High Voltage Output**

$V_{NGATE}$	Output voltage swing	$V_{NN2}$	-	$V_{NN1}$	V	No load on $V_{NGATE}$
$R_{SOURCE N}$	$V_{NGATE}$ source resistance	-	-	15.0	$\Omega$	$I_{OUT} = 80\text{mA}$
$R_{SINK N}$	$V_{NGATE}$ sink resistance	-	-	15.0	$\Omega$	$I_{OUT} = 80\text{mA}$
$t_{RISEN}$	$V_{NGATE}$ rise time	-	-	50	ns	$C_{LOAD} = 1.4\text{nF}$
$t_{FALL N}$	$V_{NGATE}$ fall time	-	-	50	ns	$C_{LOAD} = 1.4\text{nF}$
$t_{PWN(MIN)}$	$V_{NGATE}$ minimum pulse width (internally limited)	100	150	200	ns	---
$t_{DELAY N}$	$N_{IN}$ to $N_{GATE}$ delay time	-	-	300	ns	Mode = 1
$V_{NSEN}$	$V_{NGATE}$ current sense voltage	$V_{NN1} + 0.85$	$V_{NN1} + 1.0$	$V_{NN1} + 1.15$	V	---
$t_{SHORT N}$	$V_{NGATE}$ current sense off time	-	-	150	ns	---

**Control Circuitry**

$V_{IL}$	Logic input low voltage	0	-	0.60	V	$V_{DD} = 5.0\text{V}$
$V_{IH}$	Logic input high voltage	2.7	-	5.0	V	$V_{DD} = 5.0\text{V}$
$I_{INDN}$	Input pull-down current	0.5	1.0	5.0	$\mu\text{A}$	$P_{IN}, N_{IN}, \text{ENABLE}$
$R_{UP}$	Input pull-up resistance	100	200	300	$\text{K}\Omega$	MODE
$V_{OL}$	Logic output low voltage	-	-	0.50	V	$V_{DD} = 5.0\text{V}, I_{OUT} = -0.5\text{mA}$
$V_{OH}$	Logic output high voltage	4.50	-	-	V	$V_{DD} = 5.0\text{V}, I_{OUT} = +0.5\text{mA}$
$V_{RST(OFF)}$	RESET voltage, device off	3.2	-	3.5	V	$V_{DD} = 5.0\text{V}$
$V_{RST(ON)}$	RESET voltage, device on	3.7	-	4.0	V	$V_{DD} = 5.0\text{V}$

## Electrical Characteristics (cont.) (over operating supply voltage unless otherwise specified. $T_A = -40^\circ\text{C}$ to $+85^\circ\text{C}$ )

Sym	Parameter	Min	Typ	Max	Units	Conditions
$V_{RST(HYS)}$	RESET hysteresis voltage	0.3	-	-	V	$V_{DD} = 5.0\text{V}$
$I_{RESET}$	RESET pull-up current	7.0	10	13	$\mu\text{A}$	$V_{RESET} = 0 - 4.5\text{V}$
$t_{RST(ON)}$	RESET on delay	-	-	1.0	$\mu\text{s}$	---
$t_{RST(OFF)}$	RESET off delay	-	-	1.0	$\mu\text{s}$	---
$t_{EN(ON)}$	ENABLE on delay	50	100	150	$\mu\text{s}$	---
$t_{EN(OFF)}$	ENABLE off delay	-	-	1.0	$\mu\text{s}$	---
$t_{FLT(HOLD)}$	$\overline{\text{FAULT}}$ hold time	-	4	-	$N_{IN}/P_{IN}$ cycles	ENABLE = 1
$t_{DB}$	Deadband time	35	50	70	ns	Mode = 0, $R_{DB} = 5.6\text{k}\Omega$
		105	140	175		Mode = 0, $R_{DB} = 18\text{k}\Omega$
$t_{DELAY(N-P)}$	N-off to P-on transistion delay	-	-	300	ns	Mode = 0, $R_{DB} < 27\text{k}\Omega$
$t_{DELAY(P-N)}$	P-off to N-on transistion delay	-	-	300	ns	Mode = 0, $R_{DB} < 27\text{k}\Omega$
$\Delta t_{DELAY(N-P)}$	Delay difference: $t_{\text{delayN(off)}} - t_{\text{delayP(on)}}$	-80	0	80	ns	Mode = 1
$\Delta t_{DELAY(P-N)}$	Delay difference: $t_{\text{delayP(off)}} - t_{\text{delayN(on)}}$	-80	0	80	ns	Mode = 1

## Truth Table

Logic Inputs*				RESET	Output	
$N_{IN}$	$P_{IN}$	Mode	EN		External N-Channel MOSFET	External P-Channel MOSFET
L	L	H	H	$>V_{RESET(ON)}$	OFF	OFF
L	H	H	H	$>V_{RESET(ON)}$	OFF	ON
H	L	H	H	$>V_{RESET(ON)}$	ON	OFF
H	H	H	H	$>V_{RESET(ON)}$	OFF	OFF
H	X	L	H	$>V_{RESET(ON)}$	OFF	ON
L	X	L	H	$>V_{RESET(ON)}$	ON	OFF
X	X	X	L	X	OFF	OFF
X	X	X	X	$<V_{RESET(OFF)}$	OFF	OFF

**Note:**

\* Unused logic inputs should be connected to VDD or GND.

Single-Control Mode Timing

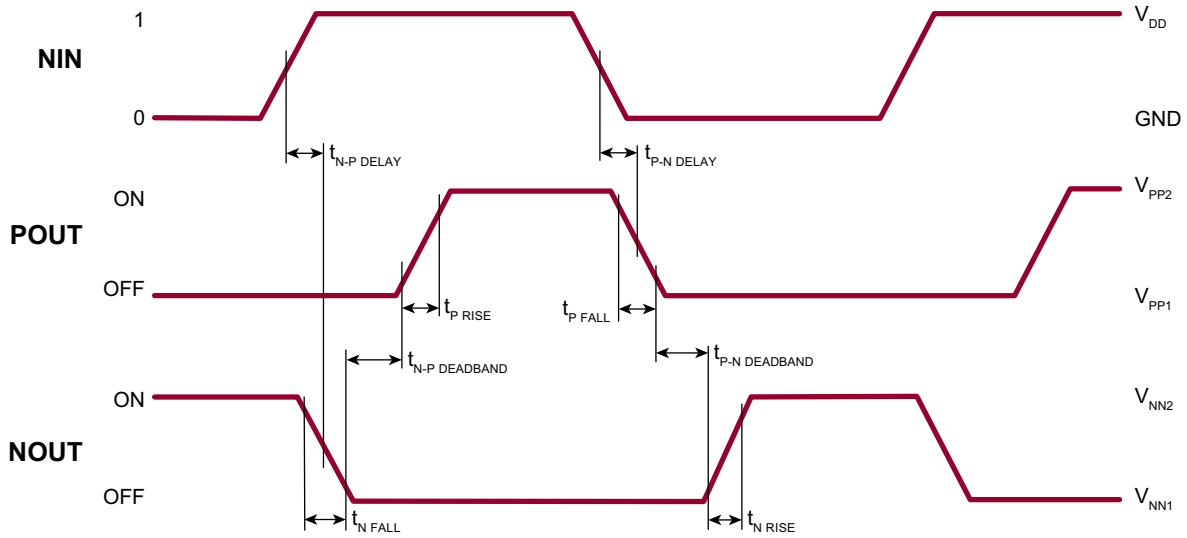

Dual-Control Mode Timing

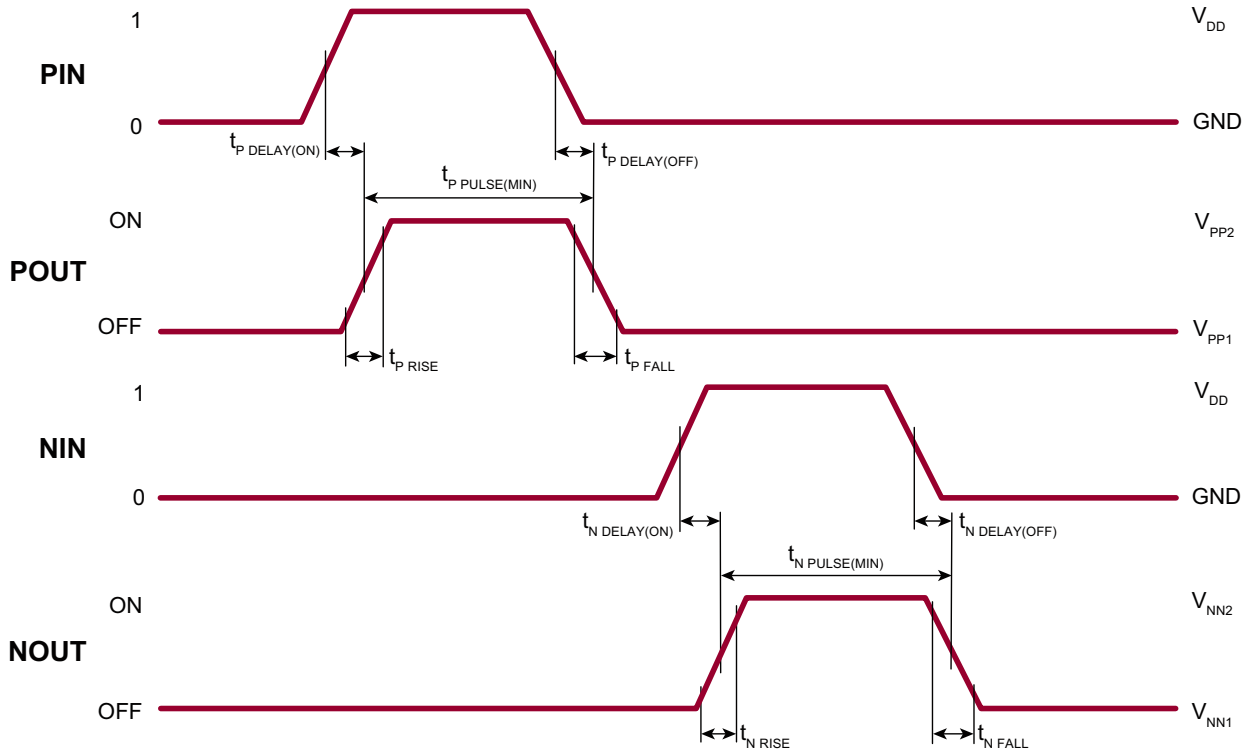

## ENABLE Timing

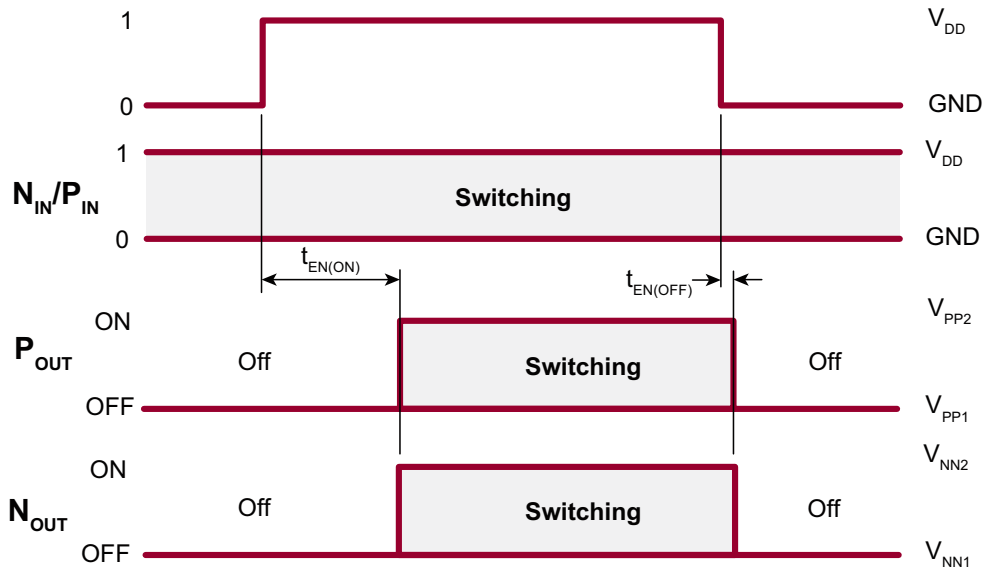

## RESET Timing

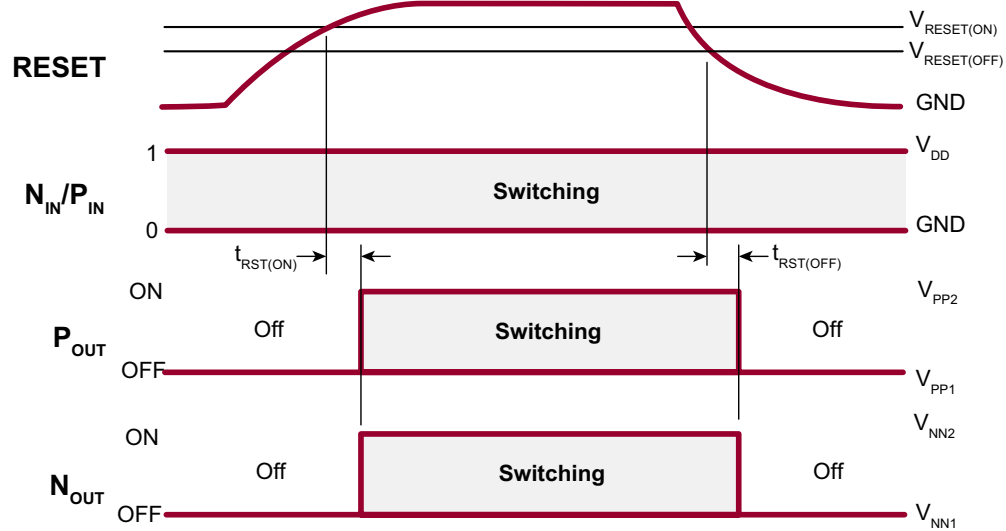

FAULT Timing

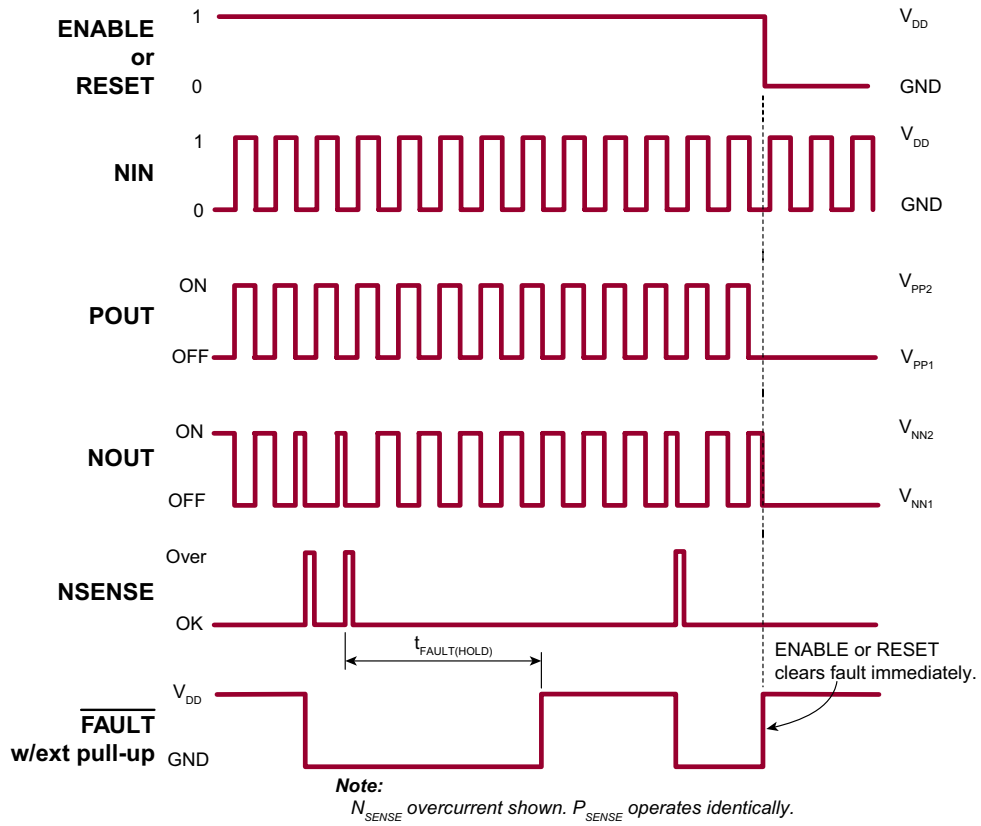

## Pin Description

Pin #	Name	Description
1	VDD	Logic supply voltage.
2	$\overline{\text{FAULT}}$	Logic output. Fault is at logic low when either current limit sense pin, VPSEN or VNSEN, is activated. Remains active until overcurrent condition clears or ENABLE = 0 or RESET = 0.
3	MODE	Logic mode input. 0 = single-control; 1 = dual-control. When MODE is high, NIN and PIN independently control $N_{\text{OUT}}$ and $P_{\text{OUT}}$ , respectively. When MODE is low, NIN controls both outputs in a complementary manner. (See Truth Table)
4	PIN	Logic control input. When mode is high, logic input high turns on the external high voltage P-channel MOSFET. Internally pulled low.
5	NIN	Logic control input. When mode is high, logic input high turns on the external high voltage N-channel MOSFET. Internally pulled low.
6	ENABLE	Logic enable input. Logic high enables IC. Internally pulled low.
7	$\overline{\text{RESET}}$	Power-on reset. A capacitor connected between this pin and ground determines the delay time between application of VDD and when the device outputs are enabled. Low leakage tantalum recommended.
8	DEADBAND	A resistor between this pin and ground sets the 'break-before-make' time between output transitions. Applicable only in single-control mode. For minimum deadtime, a 5.6k $\Omega$ resistor to ground should be used. For dual-input mode, tie to VDD.
9	SGND	Low voltage logic ground.
10	PGND	High voltage logic ground.
11	VNN2	Negative gate voltage supply. Generated by an internal linear regulator. A 25V, 100nF capacitor should be connected between VNN2 and VNN1.
12	VNN1	Negative high voltage supply.
13	VNSEN	Pulse by pulse over current sensing for N-Channel MOSFET.
14	VNGATE	Gate drive for external N-channel MOSFET.
15	N/C	No connect.
16		
17	VPGATE	Gate drive for external P-channel MOSFET.
18	VPSEN	Pulse by pulse over current sensing for P-Channel MOSFET.
19	VPP1	Positive high voltage supply.
20	VPP2	Positive gate voltage supply. Generated by an internal linear regulator. A 25V, 100nF capacitor should be connected between VPP2 and VPP1.

# 20-Lead SOW (Wide Body) Package Outline (WG)

12.80x7.50mm body, 2.65mm height (max), 1.27mm pitch

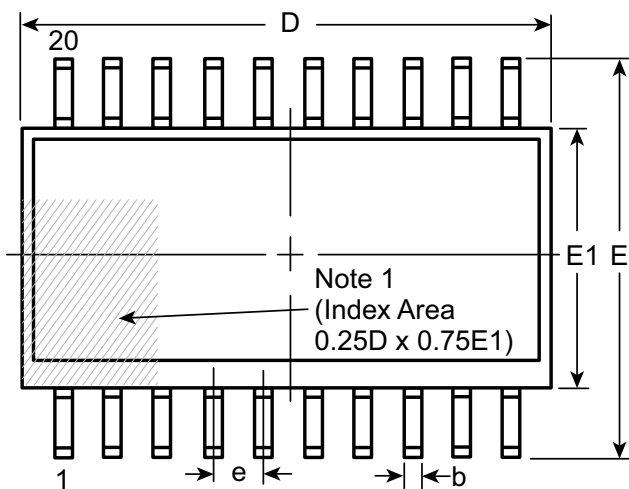

**Top View**

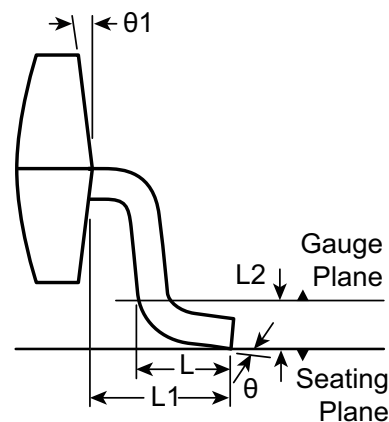

**View B**

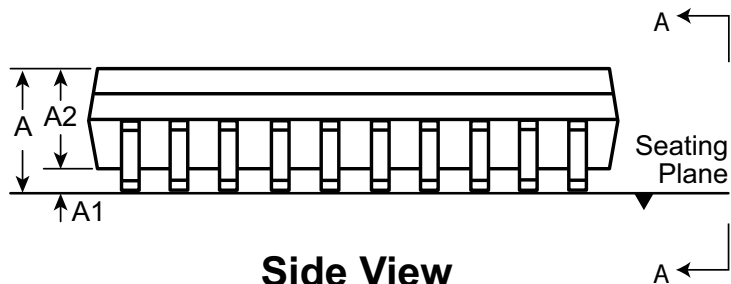

**Side View**

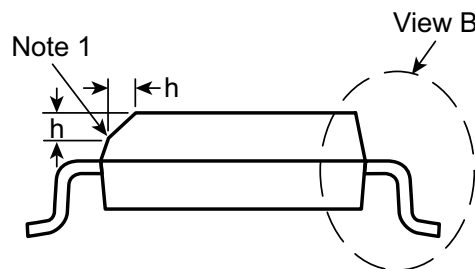

**View A-A**

**Note:**  
 1. A Pin 1 identifier must be located in the index area indicated. The Pin 1 identifier can be: a molded mark/identifier; an embedded metal marker; or a printed indicator.

Symbol		A	A1	A2	b	D	E	E1	e	h	L	L1	L2	θ	θ1
Dimension (mm)	MIN	2.15*	0.10	2.05	0.31	12.60*	9.97*	7.40*	1.27 BSC	0.25	0.40	1.40 REF	0.25 BSC	0°	5°
	NOM	-	-	-	-	12.80	10.30	7.50		-	-			-	-
	MAX	2.65	0.30	2.55*	0.51	13.00*	10.63*	7.60*		0.75	1.27			8°	15°

JEDEC Registration MS-013, Variation AC, Issue E, Sep. 2005.

\* This dimension is not specified in the JEDEC drawing.

Drawings are not to scale.



Supertex Doc. #: DSPD-20SOWWG, Version D041309.

(The package drawing(s) in this data sheet may not reflect the most current specifications. For the latest package outline information go to <http://www.supertex.com/packaging.html>.)

Supertex inc. does not recommend the use of its products in life support applications, and will not knowingly sell them for use in such applications unless it receives an adequate "product liability indemnification insurance agreement." Supertex inc. does not assume responsibility for use of devices described, and limits its liability to the replacement of the devices determined defective due to workmanship. No responsibility is assumed for possible omissions and inaccuracies. Circuitry and specifications are subject to change without notice. For the latest product specifications refer to the Supertex inc. (website: <http://www.supertex.com>)

## Looking for pricing, stock, or lifecycle information?

Click below to explore more details on WIN SOURCE:

-  [View HV430WG-G on WIN SOURCE](#)
-  [Microchip Technology](#) Information

## Optimize Your Supply Chain with WIN SOURCE Solutions

-  Global Sourcing Solution
-  Obsolete Management
-  Cost Control Management
-  Shortage Management
-  Alternative Solution
-  Excess Inventory Management