



**THE DATASHEET OF
CLVTH16244AQDLREP**



FEATURES

- **Controlled Baseline**
 - One Assembly/Test Site, One Fabrication Site
- **Extended Temperature Performance of up to -40°C to 85°C , -40°C to 125°C and -55°C to 125°C**
- **Enhanced Diminishing Manufacturing Sources (DMS) Support**
- **Enhanced Product-Change Notification**
- **Qualification Pedigree ⁽¹⁾**
- **Member of the Texas Instruments Widebus™ Family**
- **State-of-the-Art Advanced BiCMOS Technology (ABT) Design for 3.3-V Operation and Low Static-Power Dissipation**
- **Supports Mixed-Mode Signal Operation (5-V Input and Output Voltages With 3.3-V V_{CC})**
- **Supports Unregulated Battery Operation Down to 2.7 V**
- **Typical V_{OLP} (Output Ground Bounce) $<0.8\text{ V}$ at $V_{\text{CC}} = 3.3\text{ V}$, $T_{\text{A}} = 25^{\circ}\text{C}$**
- **I_{off} and Power-Up 3-State Support Hot Insertion**
- **Bus Hold on Data Inputs Eliminates the Need for External Pullup/Pulldown Resistors**
- **Latch-Up Performance Exceeds 500 mA Per JESD 17**
- **ESD Protection Exceeds JESD 22**
 - 2000-V Human-Body Model (A114-A)
 - 200-V Machine Model (A115-A)

(1) Component qualification in accordance with JEDEC and industry standards to ensure reliable operation over an extended temperature range. This includes, but is not limited to, Highly Accelerated Stress Test (HAST) or biased 85/85, temperature cycle, autoclave or unbiased HAST, electromigration, bond intermetallic life, and mold compound life. Such qualification testing should not be viewed as justifying use of this component beyond specified performance and environmental limits.

DESCRIPTION/ORDERING INFORMATION

The SN74LVTH16244A is a 16-bit buffer and line driver designed for low-voltage (3.3 V) V_{CC} operation, but with the capability to provide a TTL interface to a 5-V system environment. This device can be used as four 4-bit buffers, two 8-bit buffers, or one 16-bit buffer. This device provides true outputs and symmetrical active-low output-enable ($\overline{\text{OE}}$) inputs.

Active bus-hold circuitry holds unused or undriven inputs at a valid logic state. Use of pullup or pulldown resistors with the bus-hold circuitry is not recommended.

DGG, DGV, OR DL PACKAGE
(TOP VIEW)

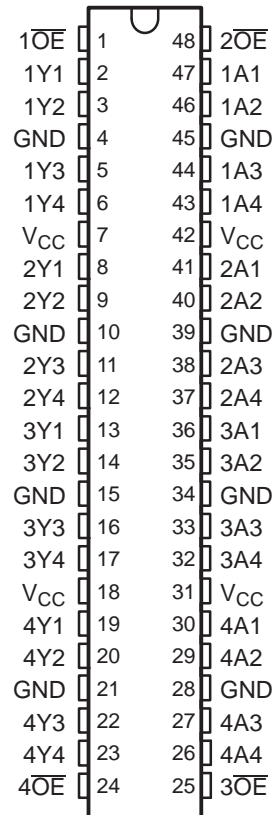

Please be aware that an important notice concerning availability, standard warranty, and use in critical applications of Texas Instruments semiconductor products and disclaimers thereto appears at the end of this data sheet.

Widebus is a trademark of Texas Instruments.

SN74LVTH16244A-EP

3.3-V ABT 16-BIT BUFFER/DRIVER WITH 3-STATE OUTPUTS

SCAS692F–APRIL 2003–REVISED APRIL 2007

When V_{CC} is between 0 V and 1.5 V, the device is in the high-impedance state during power up or power down. However, to ensure the high-impedance state above 1.5 V, \overline{OE} should be tied to V_{CC} through a pullup resistor; the minimum value of the resistor is determined by the current-sinking capability of the driver.

This device is fully specified for hot-insertion applications using I_{off} and power-up 3-state. The I_{off} circuitry disables the outputs, preventing damaging current backflow through the device when it is powered down. The power-up 3-state circuitry places the outputs in the high-impedance state during power up and power down, which prevents driver conflict.

**GQL OR ZQL PACKAGE
(TOP VIEW)**

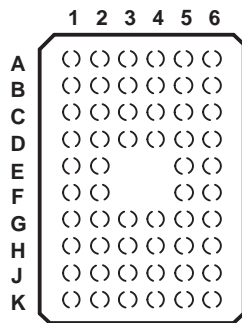

**TERMINAL ASSIGNMENTS⁽¹⁾
(56-Ball GQL/ZQL Package)**

	1	2	3	4	5	6
A	$1\overline{OE}$	NC	NC	NC	NC	$2\overline{OE}$
B	1Y2	1Y1	GND	GND	1A1	1A2
C	1Y4	1Y3	V_{CC}	V_{CC}	1A3	1A4
D	2Y2	2Y1	GND	GND	2A1	2A2
E	2Y4	2Y3			2A3	2A4
F	3Y1	3Y2			3A2	3A1
G	3Y3	3Y4	GND	GND	3A4	3A3
H	4Y1	4Y2	V_{CC}	V_{CC}	4A2	4A1
J	4Y3	4Y4	GND	GND	4A4	4A3
K	$4\overline{OE}$	NC	NC	NC	NC	$3\overline{OE}$

(1) NC - No internal connection

ORDERING INFORMATION⁽¹⁾

T_A	PACKAGE ⁽²⁾		ORDERABLE PART NUMBER	TOP-SIDE MARKING
–40°C to 125°C	SSOP – DL	Tape and reel	CLVTH16244AQLREP	LH16244AEP
	TSSOP – DGG	Tape and reel	CLVTH16244AQDGGREP	LH16244AEP
–40°C to 85°C	TVSOP – DGV	Tape and reel	CLVTH16244AIDGVREP	LL244AEP
	VFBGA – GQL	Tape and reel	CLVTH162244AIGQLREP	LL244AEP
	VFBGA – ZQL (Pb-free)		CLVTH16244AIZQLREP	
–55°C to 125°C	TSSOP – DGG	Tape and reel	CLVTH16244AMDGGREP	H16244AMEP

- (1) For the most current package and ordering information, see the Package Option Addendum at the end of this document, or see the TI website at www.ti.com.
- (2) Package drawings, standard packing quantities, thermal data, symbolization, and PCB design guidelines are available at www.ti.com/sc/package.

FUNCTION TABLE
(each 4-bit buffer)

INPUTS		OUTPUT Y
\overline{OE}	A	
L	H	H
L	L	L
H	X	Z

LOGIC DIAGRAM (POSITIVE LOGIC)

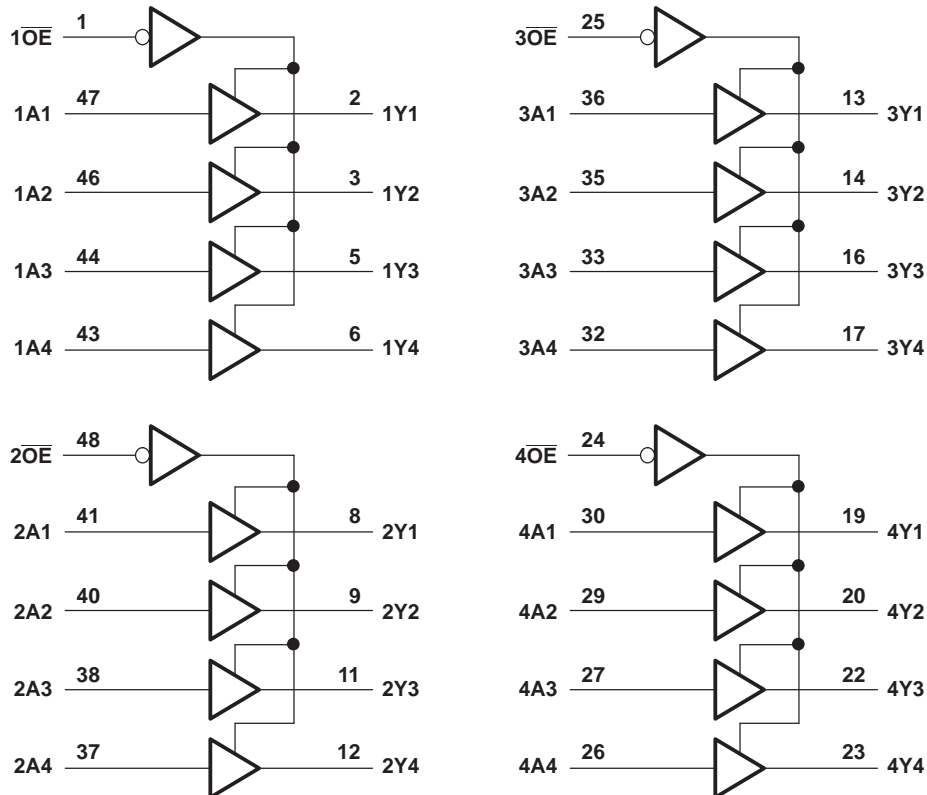

Pin numbers shown are for the DGG, DGV, and DL packages.

SN74LVTH16244A-EP

3.3-V ABT 16-BIT BUFFER/DRIVER WITH 3-STATE OUTPUTS

SCAS692F–APRIL 2003–REVISED APRIL 2007

Absolute Maximum Ratings⁽¹⁾

over operating free-air temperature range (unless otherwise noted)

		MIN	MAX	UNIT
V _{CC}	Supply voltage range	–0.5	4.6	V
V _I	Input voltage range ⁽²⁾	–0.5	7	V
V _O	Voltage range applied to any output in the high-impedance or power-off state ⁽²⁾	–0.5	7	V
V _O	Voltage range applied to any output in the high state ⁽²⁾	–0.5	V _{CC} + 0.5	V
I _O	Current into any output in the low state	SN74LVTH16244AQ	96	mA
		SN74LVTH16244AI	128	
I _O	Current into any output in the high state ⁽³⁾	SN74LVTH16244AQ	48	mA
		SN74LVTH16244AI	64	
I _{IK}	Input clamp current	V _I < 0	–50	mA
I _{OK}	Output clamp current	V _O < 0	–50	mA
θ _{JA}	Package thermal impedance ⁽⁴⁾	DGG package	70	°C/W
		DGV package	58	
		DL package	63	
		GQL/ZQL package	42	
T _{stg}	Storage temperature range	–65	150	°C

(1) Stresses beyond those listed under "absolute maximum ratings" may cause permanent damage to the device. These are stress ratings only, and functional operation of the device at these or any other conditions beyond those indicated under "recommended operating conditions" is not implied. Exposure to absolute-maximum-rated conditions for extended periods may affect device reliability.

(2) The input and output negative-voltage ratings may be exceeded if the input and output clamp-current ratings are observed.

(3) This current flows only when the output is in the high state and V_O > V_{CC}.

(4) The package thermal impedance is calculated in accordance with JESD 51-7.

Recommended Operating Conditions⁽¹⁾

		MIN	MAX	UNIT
V _{CC}	Supply voltage	2.7	3.6	V
V _{IH}	High-level input voltage	2		V
V _{IL}	Low-level input voltage		0.8	V
V _I	Input voltage		5.5	V
I _{OH}	High-level output current	SN74LVTH16244AQ	–24	mA
		SN74LVTH16244AI	–32	
		SN74LVTH16244AM	–24	
I _{OL}	Low-level output current	SN74LVTH16244AQ	24	mA
		SN74LVTH16244AI	64	
		SN74LVTH16244AM	24	
Δt/Δv	Input transition rise or fall rate		10	ns/V
Δt/ΔV _{CC}	Power-up ramp rate	200		μs/V
T _A	Operating free-air temperature	SN74LVTH16244AQ	–40	125
		SN74LVTH16244AI	–40	85
		SN74LVTH16244AM	–55	125

(1) All unused control inputs of the device must be held at V_{CC} or GND to ensure proper device operation. See the TI application report, *Implications of Slow or Floating CMOS Inputs*, literature number SCBA004.

Electrical Characteristics

over recommended operating free-air temperature range (unless otherwise noted)

PARAMETER	TEST CONDITIONS		V _{CC}	MIN	TYP ⁽¹⁾	MAX	UNIT	
V _{IK}	I _I = -18 mA		2.7 V			-1.2	V	
V _{OH}	I _{OH} = -100 μA		2.7 V to 3.6 V	V _{CC} - 0.2			V	
	I _{OH} = -8 mA		2.7 V	2.4				
	I _{OH} = -24 mA	'LVTH16244AQ		3 V	2			
		'LVTH16244AI						
		'LVTH16244AM			2			
	I _{OH} = -32 mA	'LVTH16244AQ						
'LVTH16244AI		2						
'LVTH16244AM								
V _{OL}	I _{OL} = 100 μA		2.7 V			0.2	V	
	I _{OL} = 24 mA					0.5		
	I _{OL} = 16 mA					0.4		
	I _{OL} = 32 mA	'LVTH16244AQ		3 V				
		'LVTH16244AI						0.5
		'LVTH16244AM						
I _{OL} = 64 mA	'LVTH16244AQ							
	'LVTH16244AI				0.55			
	'LVTH16244AM							
I _I		V _I = 5.5 V	0 V or 3.6 V	'LVTH16244AQ		50	μA	
				'LVTH16244AI		10		
				'LVTH16244AM		50		
	Control inputs	V _I = V _{CC} or GND		3.6 V				±1
Data inputs		V _I = V _{CC}					1	
					V _I = 0 V		-5	
I _{off}	V _I or V _O = 0 V to 4.5 V		0 V		'LVTH16244AQ		μA	
					'LVTH16244AI			±100
					'LVTH16244AM			
I _{I(hold)}	Data inputs	V _I = 0.8 V		3 V	75		μA	
		V _I = 2 V			-75			
		V _I = 0 V to 3.6 V		'LVTH16244AQ				
				'LVTH16244AI		3.6 V ⁽²⁾		500 -750
				'LVTH16244AM				
I _{OZH}	V _O = 3 V		3.6 V			5	μA	
I _{OZL}	V _O = 0.5 V		3.6 V			-5	μA	
I _{OZPU}	V _O = 0.5 V to 3 V, \overline{OE} = Don't care		0 V to 1.5 V			±100	μA	
I _{OZPD}	V _O = 0.5 V to 3 V, \overline{OE} = Don't care		1.5 V to 0 V			±100	μA	
I _{CC}	I _O = 0 , V _I = V _{CC} or GND		Outputs high		0.19		mA	
			Outputs low		5			
			Outputs disabled		0.19			
ΔI _{CC} ⁽³⁾	One input at V _{CC} - 0.6 V, Other inputs at V _{CC} or GND		3 V to 3.6 V	0.2		0.2	mA	
C _i	V _I = 3 V or 0 V				4		pF	

(1) All typical values are at V_{CC} = 3.3 V, T_A = 25°C.

(2) This is the bus-hold maximum dynamic current. It is the minimum overdrive current required to switch the input from one state to another.

(3) This is the increase in supply current for each input that is at the specified TTL voltage level, rather than V_{CC} or GND.

SN74LVTH16244A-EP
3.3-V ABT 16-BIT BUFFER/DRIVER
WITH 3-STATE OUTPUTS

SCAS692F–APRIL 2003–REVISED APRIL 2007

Electrical Characteristics (continued)

over recommended operating free-air temperature range (unless otherwise noted)

PARAMETER	TEST CONDITIONS	V _{CC}	MIN	TYP ⁽¹⁾	MAX	UNIT
C _o	V _O = 3 V or 0 V			9		pF

Switching Characteristics

over recommended operating free-air temperature range, C_L = 50 pF (unless otherwise noted) (see [Figure 1](#))

PARAMETER	FROM (INPUT)	TO (OUTPUT)	SN74LVTH16244AQ/M				SN74LVTH16244AI				UNIT	
			V _{CC} = 3.3 V ± 0.3 V		V _{CC} = 2.7 V		V _{CC} = 3.3 V ± 0.3 V			V _{CC} = 2.7 V		
			MIN	MAX	MIN	MAX	MIN	TYP	MAX	MIN		MAX
t _{PLH}	A	Y	1.1	4.4	4.6		1.2	2.5	3.2	3.7		ns
t _{PHL}			1.1	3.6	3.9		1.2	2	3.2	3.7		
t _{PZH}	\overline{OE}	Y	1.1	4.6	5.4		1.2	2.6	4	5		ns
t _{PZL}			1.1	5.4	6.2		1.2	2.7	4	5		
t _{PHZ}	\overline{OE}	Y	1.6	5.7	6.2		2.2	3.3	4.5	5		ns
t _{PLZ}			1.2	5	4.7		2	3.1	4.2	4.4		
t _{sk(o)}								0.5			ns	

PARAMETER MEASUREMENT INFORMATION

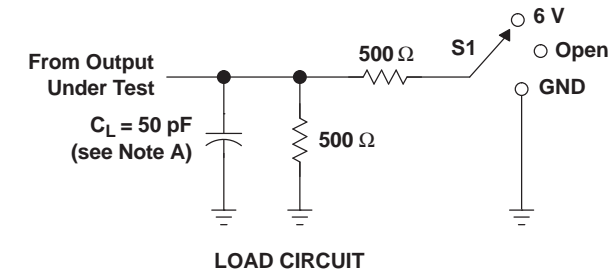

TEST	S1
t_{PLH}/t_{PHL}	Open
t_{PLZ}/t_{PZL}	6 V
t_{PHZ}/t_{PZH}	GND

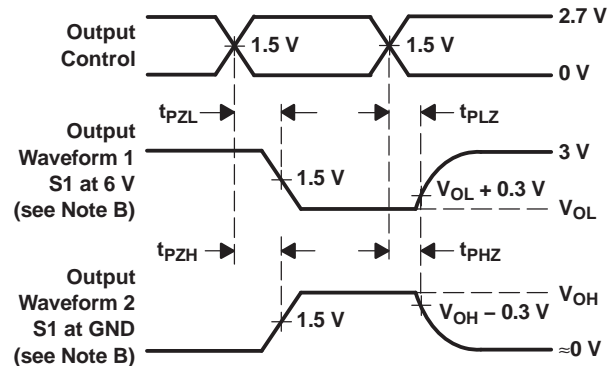
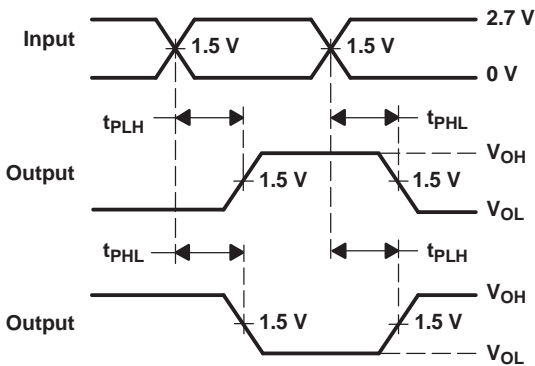
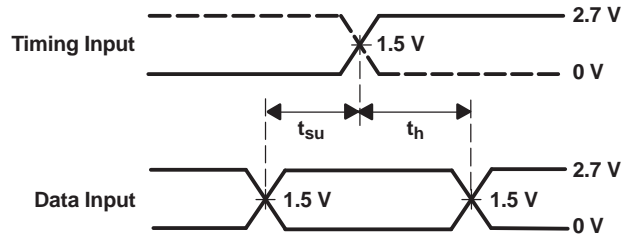
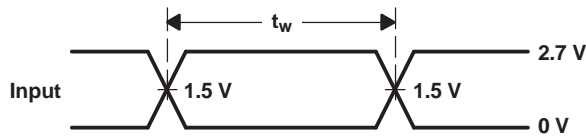

- NOTES: A. C_L includes probe and jig capacitance.
 B. Waveform 1 is for an output with internal conditions such that the output is low, except when disabled by the output control. Waveform 2 is for an output with internal conditions such that the output is high, except when disabled by the output control.
 C. All input pulses are supplied by generators having the following characteristics: $PRR \leq 10 \text{ MHz}$, $Z_O = 50 \Omega$, $t_r \leq 2.5 \text{ ns}$, $t_f \leq 2.5 \text{ ns}$.
 D. The outputs are measured one at a time, with one transition per measurement.

Figure 1. Load Circuit and Voltage Waveforms

PACKAGING INFORMATION

Orderable Device	Status (1)	Package Type	Package Drawing	Pins	Package Qty	Eco Plan (2)	Lead finish/ Ball material (6)	MSL Peak Temp (3)	Op Temp (°C)	Device Marking (4/5)	Samples
8W244AMDGGREPG4	ACTIVE	TSSOP	DGG	48	2000	RoHS & Green	NIPDAU	Level-1-260C-UNLIM	-55 to 125	H16244AMEP	Samples
CLVTH16244AIDGVREP	ACTIVE	TVSOP	DGV	48	2000	RoHS & Green	NIPDAU	Level-1-260C-UNLIM	-40 to 85	LL244AEP	Samples
CLVTH16244AMDGGREP	ACTIVE	TSSOP	DGG	48	2000	RoHS & Green	NIPDAU	Level-1-260C-UNLIM	-55 to 125	H16244AMEP	Samples
CLVTH16244AQDGGREP	ACTIVE	TSSOP	DGG	48	2000	RoHS & Green	NIPDAU	Level-1-260C-UNLIM	-40 to 125	LH16244AEP	Samples
CLVTH16244AQDLREP	ACTIVE	SSOP	DL	48	1000	RoHS & Green	NIPDAU	Level-1-260C-UNLIM	-40 to 125	LH16244AEP	Samples
V62/04601-01XE	ACTIVE	SSOP	DL	48	1000	RoHS & Green	NIPDAU	Level-1-260C-UNLIM	-40 to 125	LH16244AEP	Samples
V62/04601-01YE	ACTIVE	TSSOP	DGG	48	2000	RoHS & Green	NIPDAU	Level-1-260C-UNLIM	-40 to 125	LH16244AEP	Samples
V62/04601-02ZE	ACTIVE	TVSOP	DGV	48	2000	RoHS & Green	NIPDAU	Level-1-260C-UNLIM	-40 to 85	LL244AEP	Samples
V62/04601-03YE	ACTIVE	TSSOP	DGG	48	2000	RoHS & Green	NIPDAU	Level-1-260C-UNLIM	-55 to 125	H16244AMEP	Samples

(1) The marketing status values are defined as follows:

ACTIVE: Product device recommended for new designs.

LIFEBUY: TI has announced that the device will be discontinued, and a lifetime-buy period is in effect.

NRND: Not recommended for new designs. Device is in production to support existing customers, but TI does not recommend using this part in a new design.

PREVIEW: Device has been announced but is not in production. Samples may or may not be available.

OBSELETE: TI has discontinued the production of the device.

(2) **RoHS:** TI defines "RoHS" to mean semiconductor products that are compliant with the current EU RoHS requirements for all 10 RoHS substances, including the requirement that RoHS substance do not exceed 0.1% by weight in homogeneous materials. Where designed to be soldered at high temperatures, "RoHS" products are suitable for use in specified lead-free processes. TI may reference these types of products as "Pb-Free".

RoHS Exempt: TI defines "RoHS Exempt" to mean products that contain lead but are compliant with EU RoHS pursuant to a specific EU RoHS exemption.

Green: TI defines "Green" to mean the content of Chlorine (Cl) and Bromine (Br) based flame retardants meet JS709B low halogen requirements of <=1000ppm threshold. Antimony trioxide based flame retardants must also meet the <=1000ppm threshold requirement.

(3) MSL, Peak Temp. - The Moisture Sensitivity Level rating according to the JEDEC industry standard classifications, and peak solder temperature.

(4) There may be additional marking, which relates to the logo, the lot trace code information, or the environmental category on the device.

⁽⁵⁾ Multiple Device Markings will be inside parentheses. Only one Device Marking contained in parentheses and separated by a "-" will appear on a device. If a line is indented then it is a continuation of the previous line and the two combined represent the entire Device Marking for that device.

⁽⁶⁾ Lead finish/Ball material - Orderable Devices may have multiple material finish options. Finish options are separated by a vertical ruled line. Lead finish/Ball material values may wrap to two lines if the finish value exceeds the maximum column width.

Important Information and Disclaimer:The information provided on this page represents TI's knowledge and belief as of the date that it is provided. TI bases its knowledge and belief on information provided by third parties, and makes no representation or warranty as to the accuracy of such information. Efforts are underway to better integrate information from third parties. TI has taken and continues to take reasonable steps to provide representative and accurate information but may not have conducted destructive testing or chemical analysis on incoming materials and chemicals. TI and TI suppliers consider certain information to be proprietary, and thus CAS numbers and other limited information may not be available for release.

In no event shall TI's liability arising out of such information exceed the total purchase price of the TI part(s) at issue in this document sold by TI to Customer on an annual basis.

OTHER QUALIFIED VERSIONS OF SN74LVTH16244A-EP :

- Catalog: [SN74LVTH16244A](#)

- Military: [SN54LVTH16244A](#)

NOTE: Qualified Version Definitions:

- Catalog - TI's standard catalog product

- Military - QML certified for Military and Defense Applications

TAPE AND REEL INFORMATION

QUADRANT ASSIGNMENTS FOR PIN 1 ORIENTATION IN TAPE

*All dimensions are nominal

Device	Package Type	Package Drawing	Pins	SPQ	Reel Diameter (mm)	Reel Width W1 (mm)	A0 (mm)	B0 (mm)	K0 (mm)	P1 (mm)	W (mm)	Pin1 Quadrant
CLVTH16244AIDGVREP	TVSOP	DGV	48	2000	330.0	16.4	7.1	10.2	1.6	12.0	16.0	Q1
CLVTH16244AMDGGREP	TSSOP	DGG	48	2000	330.0	24.4	8.6	13.0	1.8	12.0	24.0	Q1
CLVTH16244AQDGGREP	TSSOP	DGG	48	2000	330.0	24.4	8.6	13.0	1.8	12.0	24.0	Q1
CLVTH16244AQDLREP	SSOP	DL	48	1000	330.0	32.4	11.35	16.2	3.1	16.0	32.0	Q1

TAPE AND REEL BOX DIMENSIONS

*All dimensions are nominal

Device	Package Type	Package Drawing	Pins	SPQ	Length (mm)	Width (mm)	Height (mm)
CLVTH16244AIDGVREP	TVSOP	DGV	48	2000	356.0	356.0	35.0
CLVTH16244AMDGGREP	TSSOP	DGG	48	2000	367.0	367.0	45.0
CLVTH16244AQDGGREP	TSSOP	DGG	48	2000	367.0	367.0	45.0
CLVTH16244AQLREP	SSOP	DL	48	1000	367.0	367.0	55.0

EXAMPLE BOARD LAYOUT

DGG0048A

TSSOP - 1.2 mm max height

SMALL OUTLINE PACKAGE



LAND PATTERN EXAMPLE
SCALE:6X



SOLDER MASK DETAILS

4214859/B 11/2020

NOTES: (continued)

5. Publication IPC-7351 may have alternate designs.
6. Solder mask tolerances between and around signal pads can vary based on board fabrication site.

EXAMPLE STENCIL DESIGN

DGG0048A

TSSOP - 1.2 mm max height

SMALL OUTLINE PACKAGE

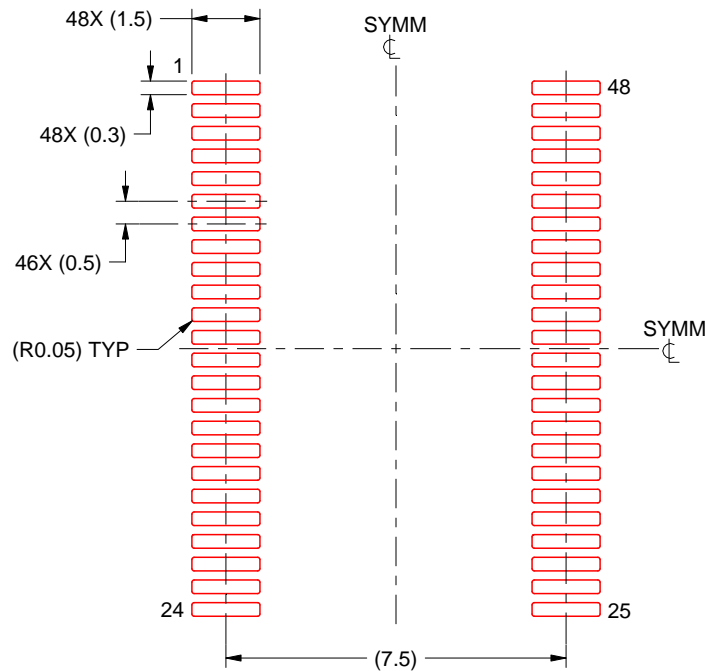

SOLDER PASTE EXAMPLE
BASED ON 0.125 mm THICK STENCIL
SCALE:6X

4214859/B 11/2020

NOTES: (continued)

7. Laser cutting apertures with trapezoidal walls and rounded corners may offer better paste release. IPC-7525 may have alternate design recommendations.
8. Board assembly site may have different recommendations for stencil design.

DGG (R-PDSO-G**)

PLASTIC SMALL-OUTLINE PACKAGE

48 PINS SHOWN



- NOTES: A. All linear dimensions are in millimeters.
 B. This drawing is subject to change without notice.
 C. Body dimensions do not include mold protrusion not to exceed 0,15.
 D. Falls within JEDEC MO-153

IMPORTANT NOTICE AND DISCLAIMER

TI PROVIDES TECHNICAL AND RELIABILITY DATA (INCLUDING DATA SHEETS), DESIGN RESOURCES (INCLUDING REFERENCE DESIGNS), APPLICATION OR OTHER DESIGN ADVICE, WEB TOOLS, SAFETY INFORMATION, AND OTHER RESOURCES "AS IS" AND WITH ALL FAULTS, AND DISCLAIMS ALL WARRANTIES, EXPRESS AND IMPLIED, INCLUDING WITHOUT LIMITATION ANY IMPLIED WARRANTIES OF MERCHANTABILITY, FITNESS FOR A PARTICULAR PURPOSE OR NON-INFRINGEMENT OF THIRD PARTY INTELLECTUAL PROPERTY RIGHTS.

These resources are intended for skilled developers designing with TI products. You are solely responsible for (1) selecting the appropriate TI products for your application, (2) designing, validating and testing your application, and (3) ensuring your application meets applicable standards, and any other safety, security, regulatory or other requirements.

These resources are subject to change without notice. TI grants you permission to use these resources only for development of an application that uses the TI products described in the resource. Other reproduction and display of these resources is prohibited. No license is granted to any other TI intellectual property right or to any third party intellectual property right. TI disclaims responsibility for, and you will fully indemnify TI and its representatives against, any claims, damages, costs, losses, and liabilities arising out of your use of these resources.

TI's products are provided subject to [TI's Terms of Sale](#) or other applicable terms available either on ti.com or provided in conjunction with such TI products. TI's provision of these resources does not expand or otherwise alter TI's applicable warranties or warranty disclaimers for TI products.

TI objects to and rejects any additional or different terms you may have proposed.

Mailing Address: Texas Instruments, Post Office Box 655303, Dallas, Texas 75265
Copyright © 2022, Texas Instruments Incorporated

Looking for pricing, stock, or lifecycle information?

Click below to explore more details on WIN SOURCE:

 [View CLVTH16244AQDLREP on WIN SOURCE](#)

 [Texas Instruments](#) Information

Optimize Your Supply Chain with WIN SOURCE Solutions

-  Global Sourcing Solution
-  Obsolete Management
-  Cost Control Management
-  Shortage Management
-  Alternative Solution
-  Excess Inventory Management