



**THE DATASHEET OF
TGHGCR0100FE**



TGHG Series

Precision Current Sense Resistors



The TGHG Series uses state of the art technology to provide highly reliable, non inductive performance. This resistor is ideal for many current monitoring and controls applications.



FEATURES

- Resistance values beginning at 0.5mΩ
- Non Inductive
- Four terminal Kelvin connection
- SOT 227 Package
- Four terminals to isolate measurement path from current flow path
- Accuracy in a high power package

CHARACTERISTICS

Heat Sink	Nickel-plated copper
Terminal Nuts	American standard 303 stainless steel
Standard Resistance Values	0.5mΩ-1Ω, others on request
Resistance Tolerances	0.5% (0.0005 thru 0.022Ω), 1%, 5%
Temperature Coefficient	referenced to 25°C, ΔR taken at -15°C and +105°C, <60ppm/°C; <500ppm/°C for resistance range 27mΩ-49mΩ)
Power Rating	100W at 70°C case temperature; 150Amp permanent not to exceed Ohms Law power load.
Dielectric strength	1000VDC, higher value on request
Heat Resistance	R _{th} <0.56K/W
Protection class	acc. to IEC 950/CSA22.2 950/M -89 and EN 60950.88:2
Working Temp. Range	-55°C to +155°C
Max. Torque for Contacts	1.3Nm 8 (static)
Max Torque for Base Plate	1.5 Nm (static)

Derating

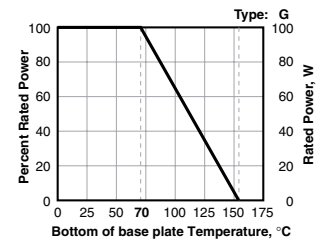

Best results can be reached by using a thermal transfer compound with a heat conductivity of better than 1W/mK

THIS PRODUCT IS DESIGNED FOR USE WITH PROPER HEATSINKING.

Maximum base plate temperature of the resistor must be monitored and kept within specified limits to establish the power rating. Best technique is to attach a thermocouple to the side of the base plate of the resistor. Temperature of plastic housing or heat sink cannot be used to establish rating of the resistor.

(continued)

TGHG Series

Precision Current Sense Resistors

DIMENSIONS

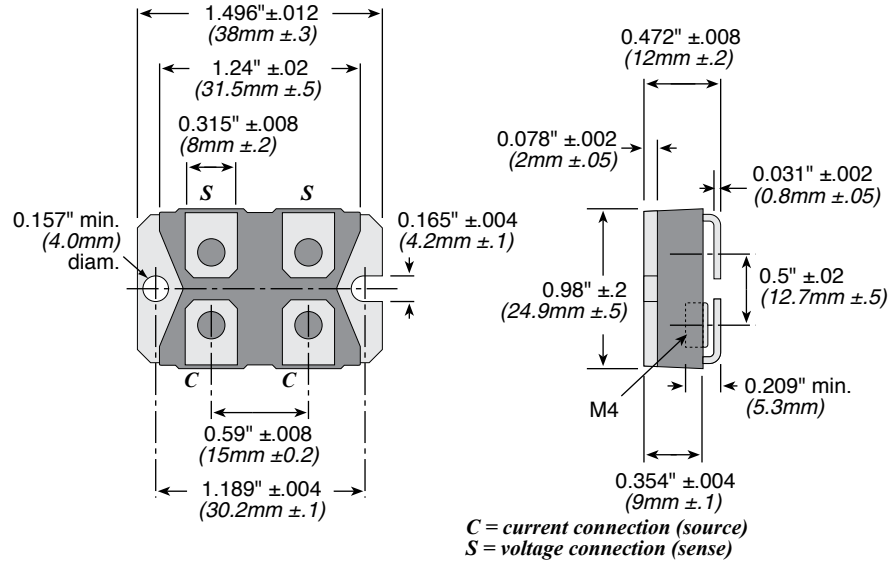

ORDERING INFORMATION

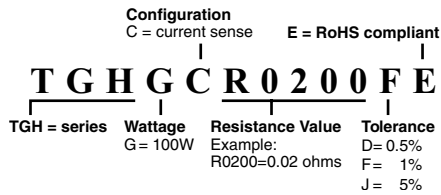

Standard part numbers

Ohms	100 Watt 0.5%	100 Watt 1%
0.00050		TGHGCR0005FE
0.00100	TGHGCR0010DE	TGHGCR0010FE
0.00200	TGHGCR0020DE	TGHGCR0020FE
0.00500	TGHGCR0050DE	TGHGCR0050FE
0.01000	TGHGCR0100DE	TGHGCR0100FE
0.01500		TGHGCR0150FE
0.02000	TGHGCR0200DE	TGHGCR0200FE
0.02500		TGHGCR0250FE
0.05000		TGHGCR0500FE
0.0750		TGHGCR0750FE
0.1000		TGHGCR1000FE

Looking for pricing, stock, or lifecycle information?

Click below to explore more details on WIN SOURCE:

 [View TGHGCR0100FE on WIN SOURCE](#)

 [Ohmite Information](#)

Optimize Your Supply Chain with WIN SOURCE Solutions

-  Global Sourcing Solution
-  Obsolete Management
-  Cost Control Management
-  Shortage Management
-  Alternative Solution
-  Excess Inventory Management