



**THE DATASHEET OF**  
**2170507-1**



LOC	DIST	REV	DATE	BY	CHK
-	-	5	15JAN2014	BL	JY
-	-	6	27MAY2014	BL	JY
-	-	7	27JAN2015	RG	MC
-	-	A	7MAR2016	RG	SH

- ① CAGE ASSEMBLY MATERIAL: NICKEL SILVER, 0.25 THICK  
 HEAT SINK MATERIAL: ALUMINUM  
 HEAT SINK CLIP MATERIAL: STAINLESS STEEL  
 EMI SPRING MATERIAL: COPPER ALLOY  
 EMI GASKET PLATE MATERIAL: STAINLESS STEEL  
 LIGHT PIPE MATERIAL: CLEAR POLYCARBONATE
- ② PITCH BETWEEN PORTS OF ONE 1X3 CAGE ASSEMBLY.
- ③ SPACING BETWEEN CAGES ON THE SAME PC BOARD, TO BE SPECIFIED BY CUSTOMER, MUST COMPLY WITH MINIMUM DIMENSIONS SHOWN.
- ④ REFERENCE APPLICATION SPEC 114-13217 FOR RECOMMENDED DRILL HOLE DIAMETER AND PLATING THICKNESS.
- ⑤ DATUMS AND BASIC DIMENSIONS ESTABLISHED BY CUSTOMER.
- ⑥ DIMENSION F IS THE NOMINAL THICKNESS OF CUSTOMER SUPPLIED PC BOARD,  
 SINGLE SIDED PC BOARD MINIMUM THICKNESS = 1.45mm  
 DOUBLE SIDED PC BOARD MINIMUM THICKNESS = 5.0mm PER CUSTOMER.
- ⑦ HEAT SINKS, LIGHT PIPES, AND HEAT SINK CLIPS SHIPPED ASSEMBLED TO CAGE ASSEMBLY. CAGE ASSEMBLY MAY BE PRESSED INTO THE PCB AS SHIPPED.
- ⑧ DATUM A IS TOP SURFACE OF PC BOARD.
- ⑨ DIMENSION APPLIES WITH MODULE INSERTED IN CAGE.
- ⑩ UNPLATED THRU HOLE.
- 11. MATES WITH QSFP MSA COMPATIBLE TRANSCEIVER.
- ⑫ SURFACE TRACES PERMITTED WITHIN THIS AREA EXCEPT WHERE CAGE STANDOFFS, SHOWN IN DETAIL S, CONTACT PC BOARD.
- ⑬ BASELINE FOR THESE DIMENSIONS IS THE CENTER OF COMPLIANT PIN HOLE.
- ⑭ DATE CODE (YYWWD) MARKED ON TOP OF CAGE AND CONCEALED BY HEAT SINKS APPLIES TO CAGE ASSEMBLY ONLY.

- ⑮ REFERENCE APP SPEC 114-13217 FOR GASKET THICKNESS CALCULATION.
- ⑯ EMI SPRING FINISH: 2um MINIMUM TIN  
 HEAT SINK FINISH: BLACK ANODIZED.
- ⑰ HEAT SINKS AND CLIPS SHIPPED ASSEMBLED TO CAGE ASSEMBLY. CAGE ASSEMBLY MAY BE PRESSED INTO THE PCB AS SHIPPED. LIGHT PIPES, SHIPPED UNATTACHED, MUST BE ASSEMBLED BY CUSTOMER AFTER THE CAGE IS SEATED IN THE PCB.

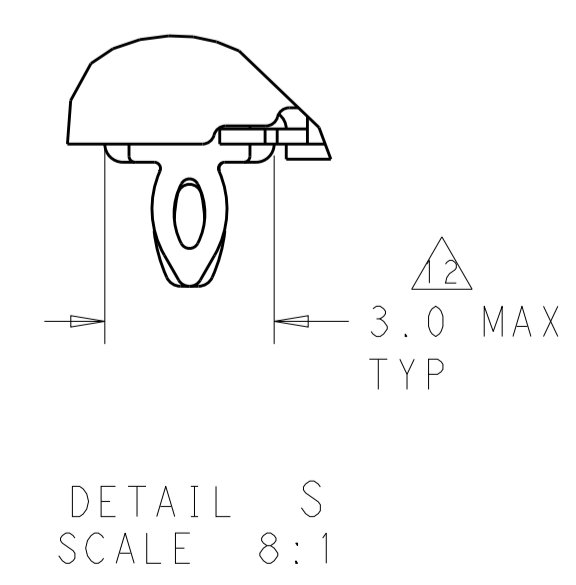
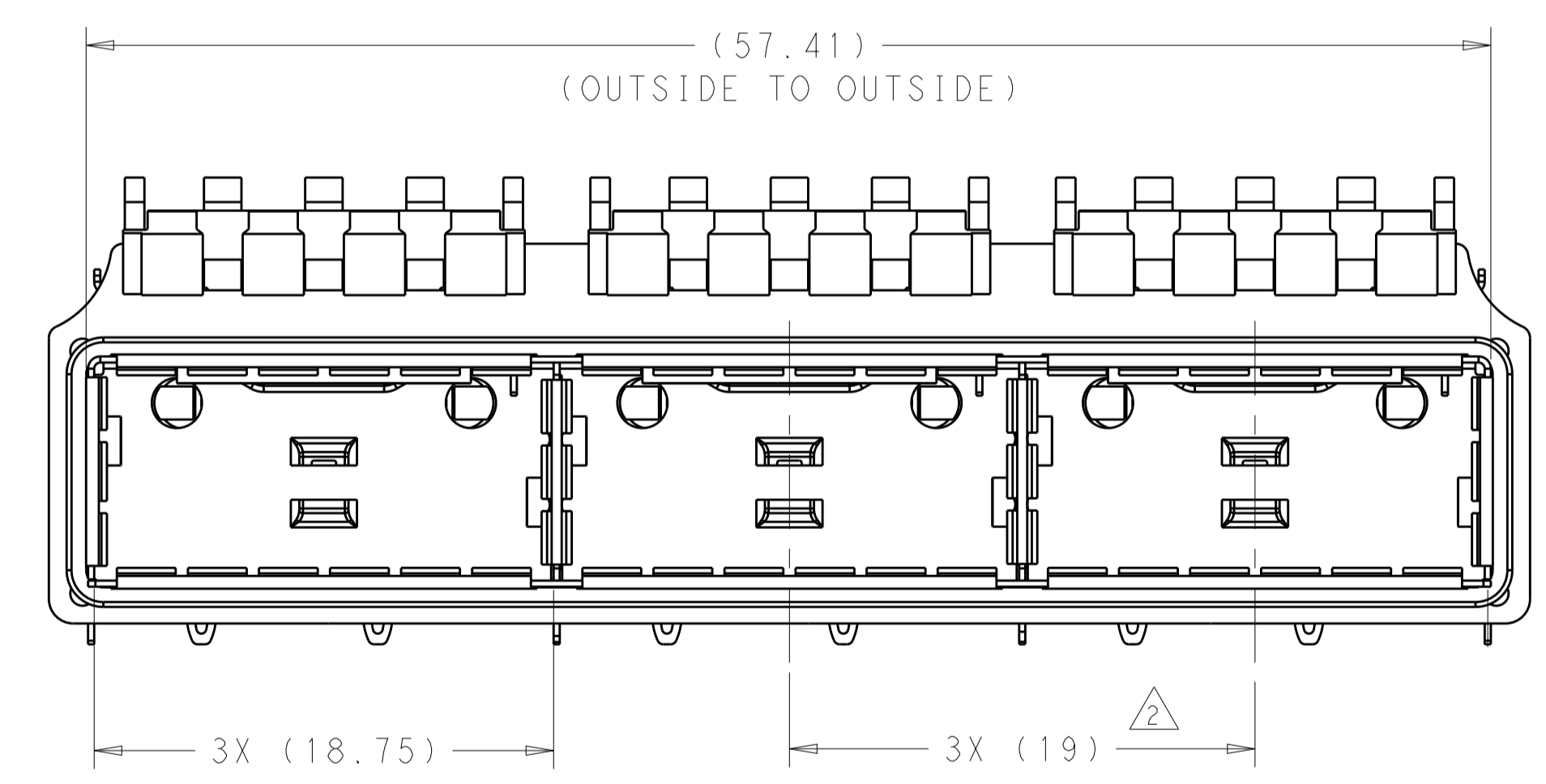
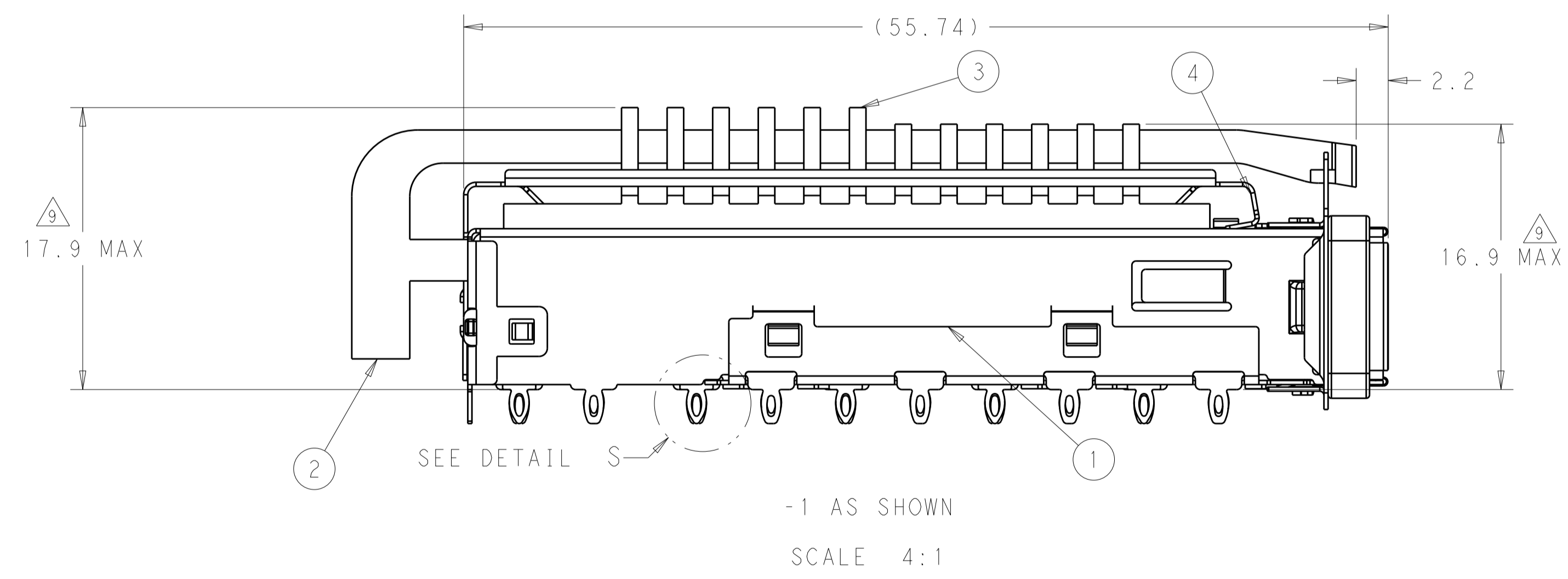

SOLID, SQUARE GASKET	WITHOUT LP	WITH HS	2170507-4
HOLLOW, ROUND GASKET	WITH LP	WITH HS	2170507-3
HOLLOW, ROUND GASKET	WITHOUT LP	WITHOUT HS	2170507-2
SOLID, SQUARE GASKET	WITH LP	WITH HS	2170507-1
GASKET	LIGHT PIPE	HEAT SINK	PART NUMBER

  

THIS DRAWING IS A CONTROLLED DOCUMENT.		OWN: TIM XUE 27MAR2013	TE Connectivity
DIMENSIONS: mm		CHK: ALEX CAI 27MAR2013	
TOLERANCES UNLESS OTHERWISE SPECIFIED:		APVD: ALEX CAI 27MAR2013	NAME: 1X3 CAGE ASSEMBLY, THRU BEZEL W/ELASTOMERIC GASKET AND HEAT SINKS QSFP
0 PLC ±	1 PLC ±0.35	PRODUCT SPEC 108-2286	SIZE: CAGE CODE DRAWING NO
2 PLC ±0.25	3 PLC ±	APPLICATION SPEC 114-13217	RESTRICTED TO
4 PLC ±	ANGLES ±	WEIGHT	A100779C=2170507
MATERIAL	FINISH	CUSTOMER DRAWING	SCALE 1:1 SHEET 1 OF 6 REV A

LOC	DIST	REV	DATE	BY	APPV
		1			

REVISIONS		DATE	BY	APPV
P	LTM			
- SEE SHEET 1				

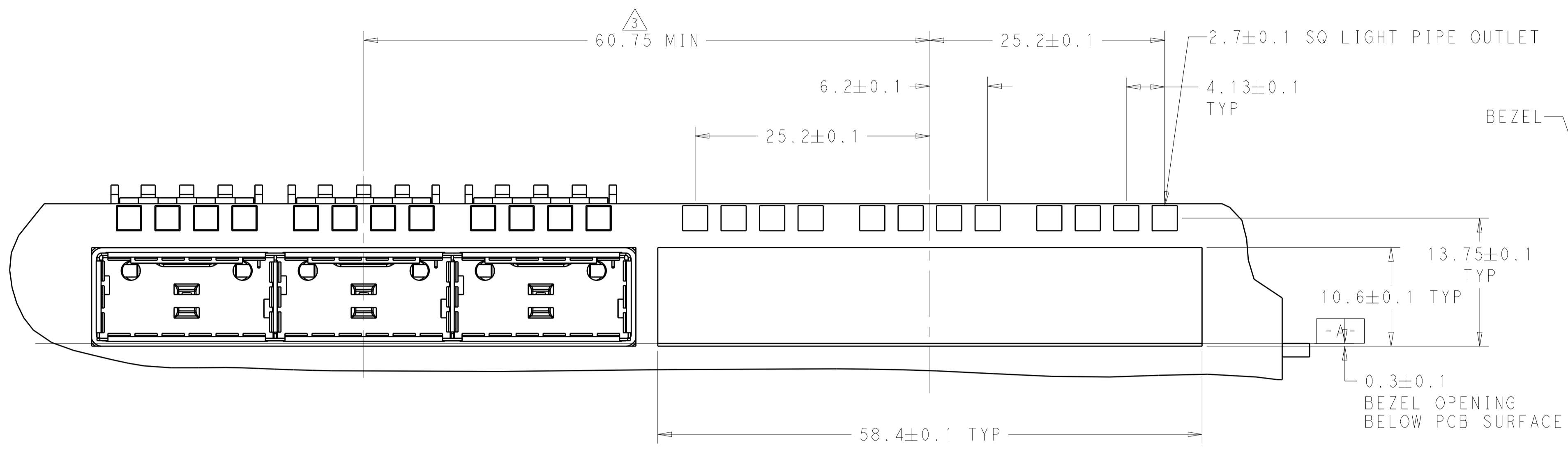

ONE SIDED CONFIGURATION  
 SCALE 3:1

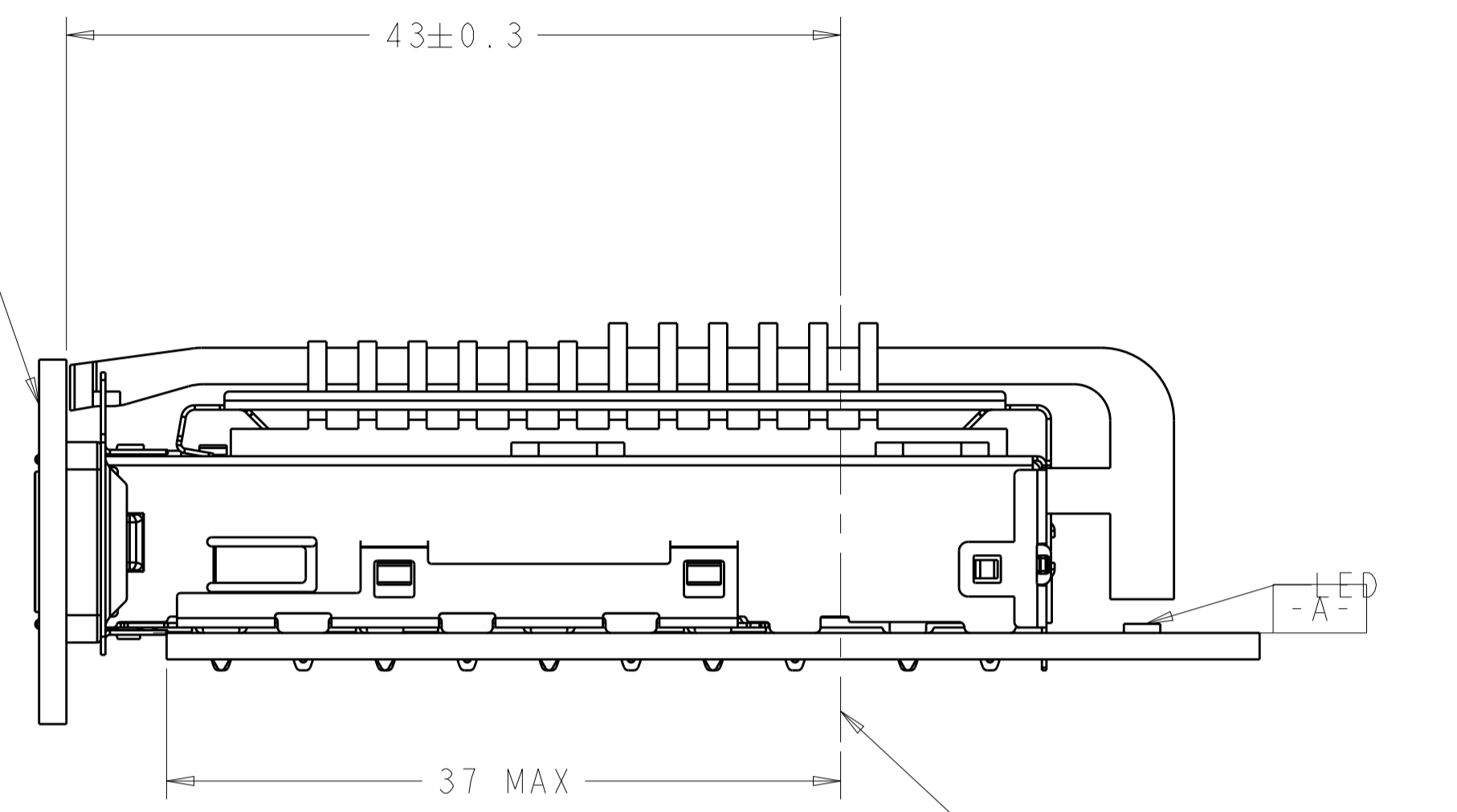

SCALE 3:1

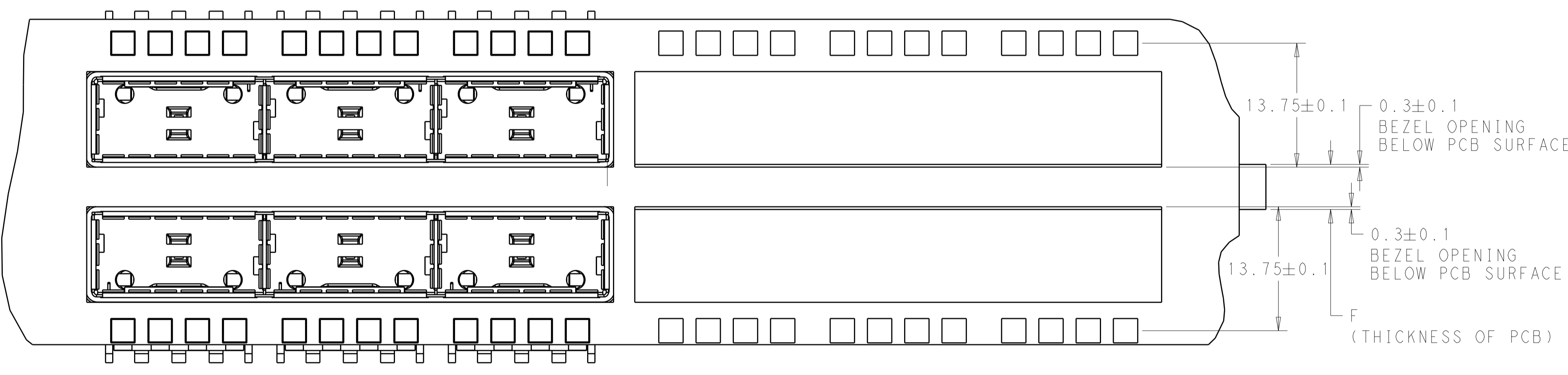

BELLY TO BELLY CONFIGURATION  
 SIMILAR TO ONE SIDED  
 EXCEPT WHERE NOTED  
 SCALE 3:1

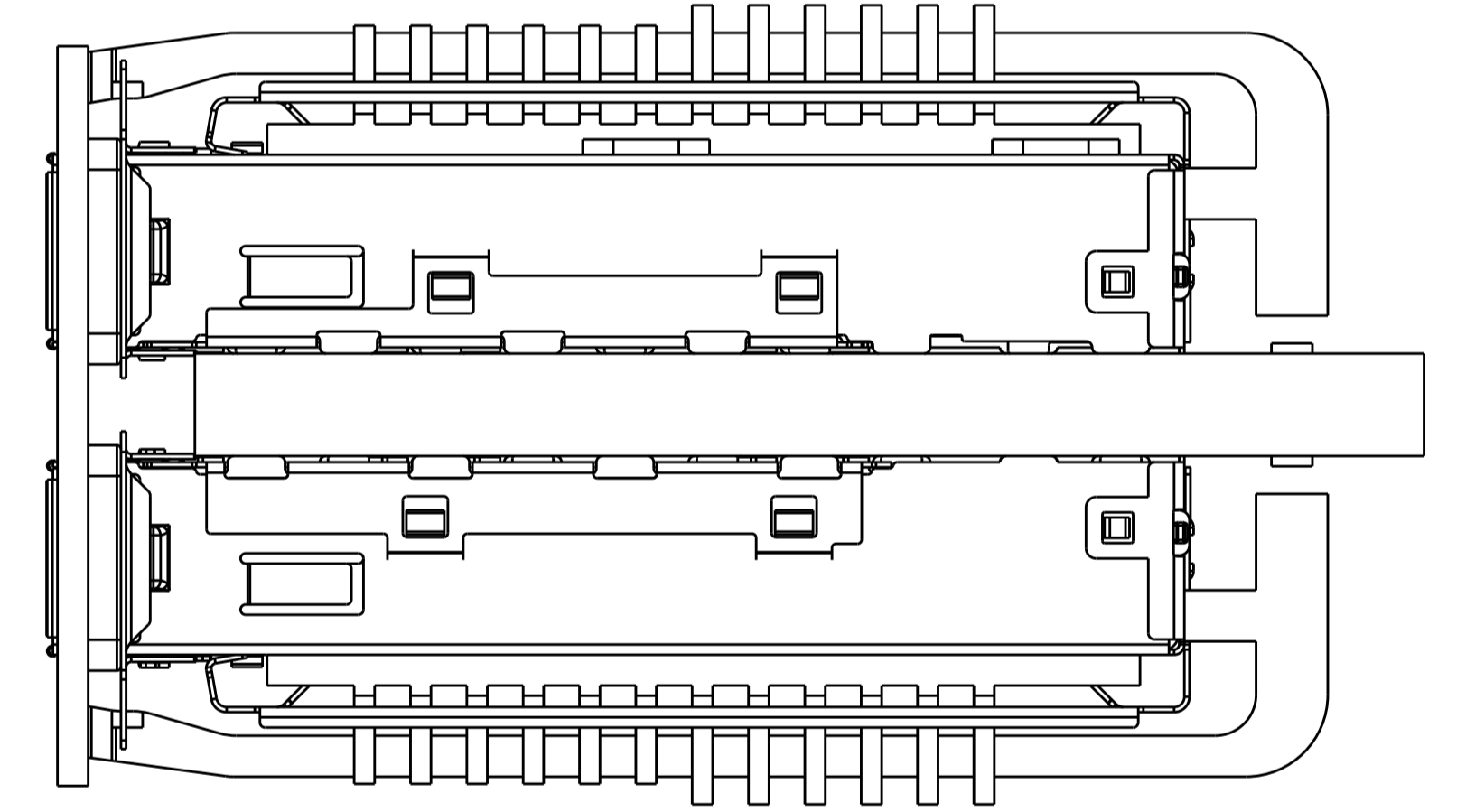

SCALE 3:1

THIS DRAWING IS A CONTROLLED DOCUMENT.		OWN: TIM XUE 27MAR2013	TE Connectivity
DIMENSIONS: mm		CHK: ALEX CAI 27MAR2013	
TOLERANCES UNLESS OTHERWISE SPECIFIED:		APVD: ALEX CAI 27MAR2013	NAME: 1X3 CAGE ASSEMBLY, THRU BEZEL W/ELASTOMERIC GASKET AND HEAT SINKS OSFP
0 PLC ±	1 PLC ±0.35	PRODUCT SPEC	SIZE: CAGE CODE DRAWING NO
2 PLC ±0.25	3 PLC ±	108-2286	A100779C=2170507
4 PLC ±	ANGLES ±	APPLICATION SPEC	RESTRICTED TO
MATERIAL	FINISH	WEIGHT	SCALE 1:1 SHEET 2 OF 6 REV A
CUSTOMER DRAWING			

LOC	DIST	REV	DATE	BY	APPV
		1			

  

REVISIONS		DATE	BY	APPV
1	SEE SHEET 1			

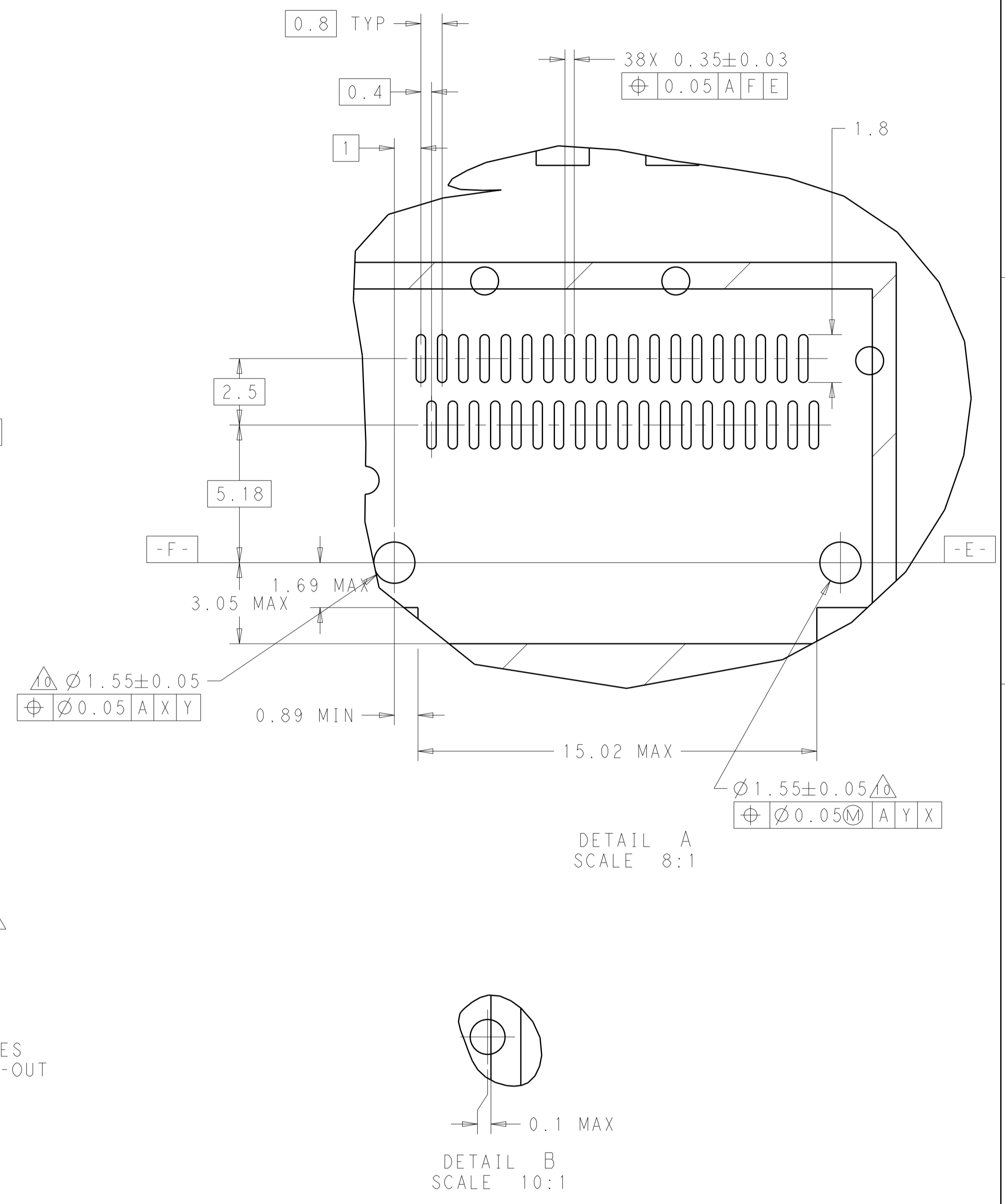
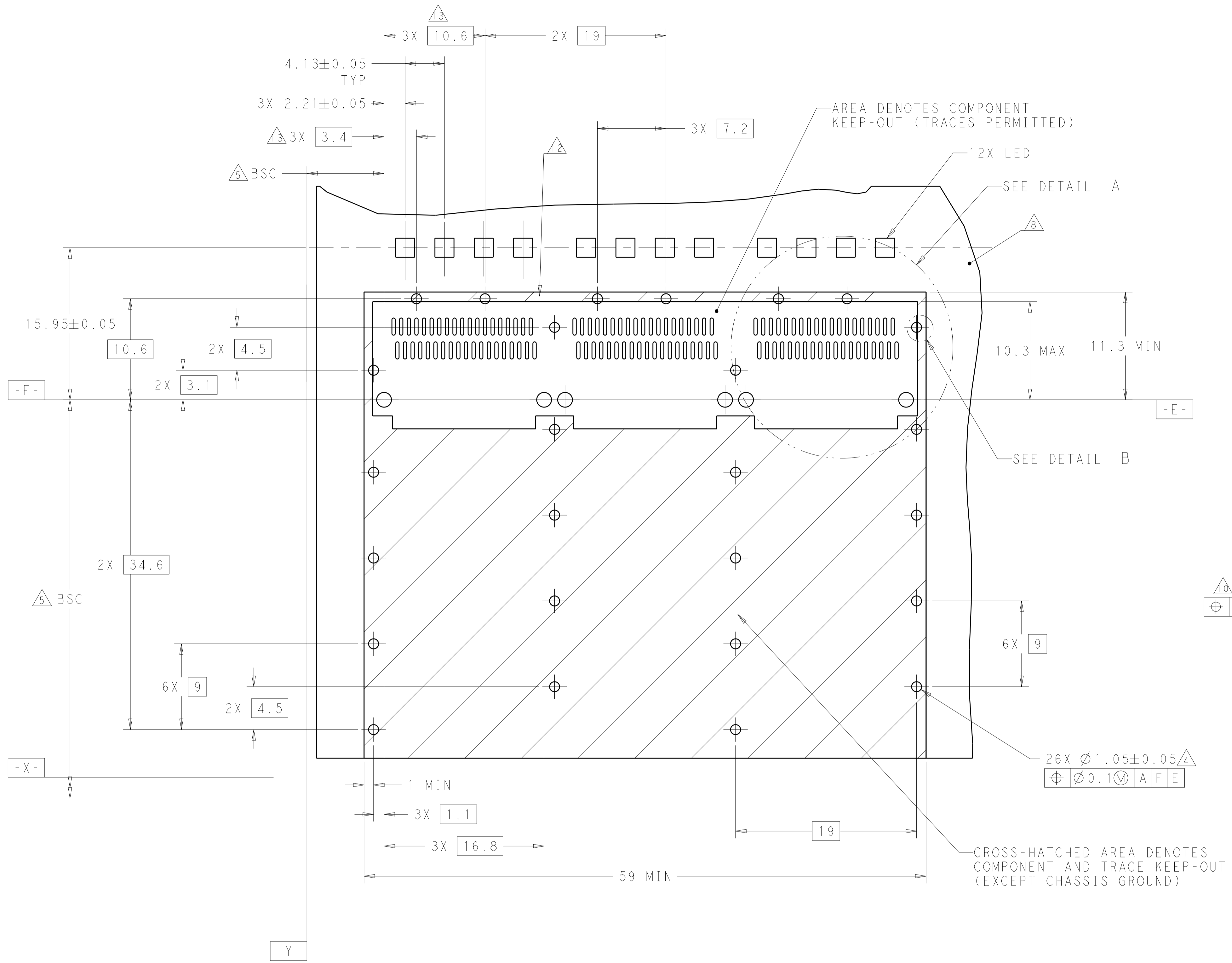

THIS DRAWING IS A CONTROLLED DOCUMENT.		OWN: TIM XUE 27MAR2013	TE Connectivity
DIMENSIONS: mm		CHK: ALEX CAI 27MAR2013	
TOLERANCES UNLESS OTHERWISE SPECIFIED:		APVD: ALEX CAI 27MAR2013	NAME: 1X3 CAGE ASSEMBLY, THRU BEZEL W/ELASTOMERIC GASKET AND HEAT SINKS QSPF
0 PLC ±	1 PLC ±0.35	PRODUCT SPEC: 108-2286	SIZE: 114-13217
2 PLC ±0.25	3 PLC ±	APPLICATION SPEC: 114-13217	WEIGHT: -
4 PLC ±	ANGLES ±	CUSTOMER DRAWING	SCALE: 1:1 SHEET 3 OF 6 REV A

LOC	DIST	REVISIONS			
P	LTN	DESCRIPTION	DATE	DWN	APVD
-	-	SEE SHEET 1	-	-	-

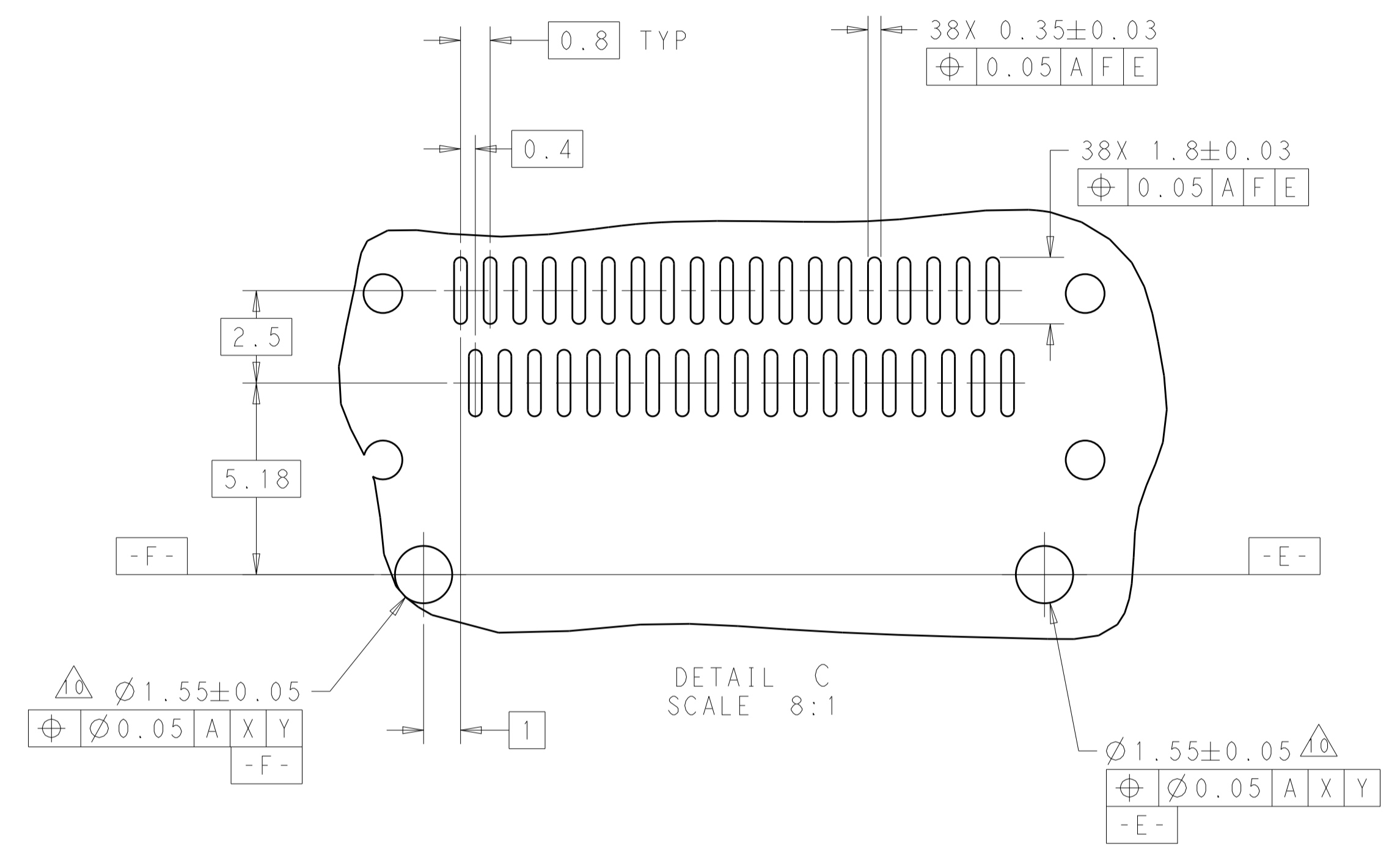
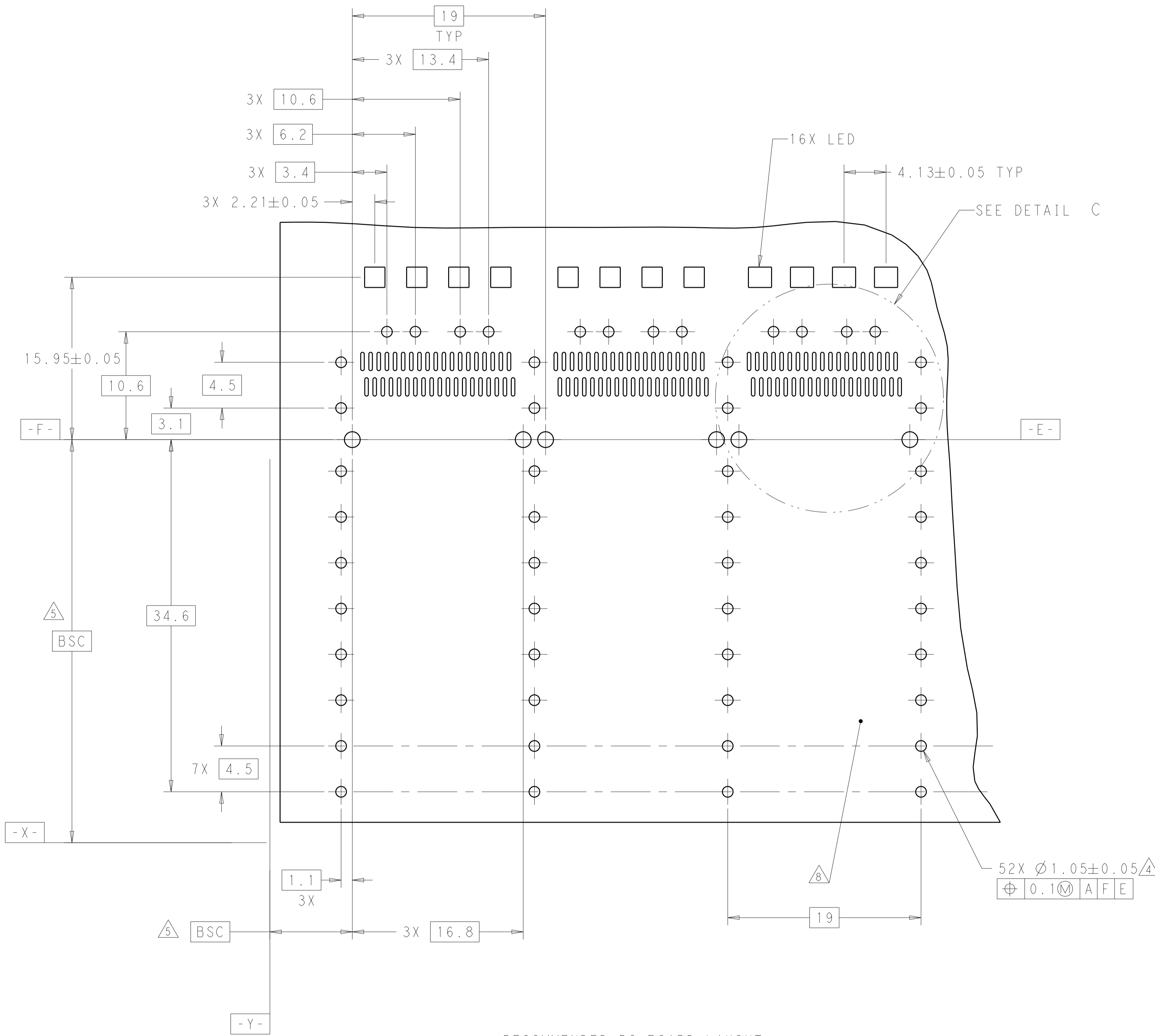

RECOMMENDED PC BOARD LAYOUT  
 BELLY TO BELLY CONFIGURATION  
 SEE SHEET 3 FOR COMPONENT AND TRACE KEEP-OUTS  
 SCALE 4:1

THIS DRAWING IS A CONTROLLED DOCUMENT.		DWN TIM XUE 27MAR2013	TE Connectivity														
DIMENSIONS:		CHK ALEX CAI 27MAR2013															
mm	TOLERANCES UNLESS OTHERWISE SPECIFIED:	APVD ALEX CAI 27MAR2013	NAME 1X3 CAGE ASSEMBLY, THRU BEZEL W/ELASTOMERIC GASKET AND HEAT SINKS QSFP														
<table border="1"> <tr><td>0 PLC</td><td>±</td></tr> <tr><td>1 PLC</td><td>±0.35</td></tr> <tr><td>2 PLC</td><td>±0.25</td></tr> <tr><td>3 PLC</td><td>±</td></tr> <tr><td>4 PLC</td><td>±</td></tr> </table>	0 PLC	±	1 PLC	±0.35	2 PLC	±0.25	3 PLC	±	4 PLC	±	<table border="1"> <tr><td>ANGLES</td><td>±</td></tr> <tr><td>FINISH</td><td>±</td></tr> </table>	ANGLES	±	FINISH	±	PRODUCT SPEC 108-2286 APPLICATION SPEC 114-13217 WEIGHT -	SIZE A100779C=2170507 RESTRICTED TO -
0 PLC	±																
1 PLC	±0.35																
2 PLC	±0.25																
3 PLC	±																
4 PLC	±																
ANGLES	±																
FINISH	±																
MATERIAL	FINISH	CUSTOMER DRAWING	SCALE 1:1 SHEET 4 OF 6 REV A														

LOC		DIST		REVISIONS			
P	LTN	DESCRIPTION	DATE	DWN	APVD		
-	-	SEE SHEET 1	-	-	-		

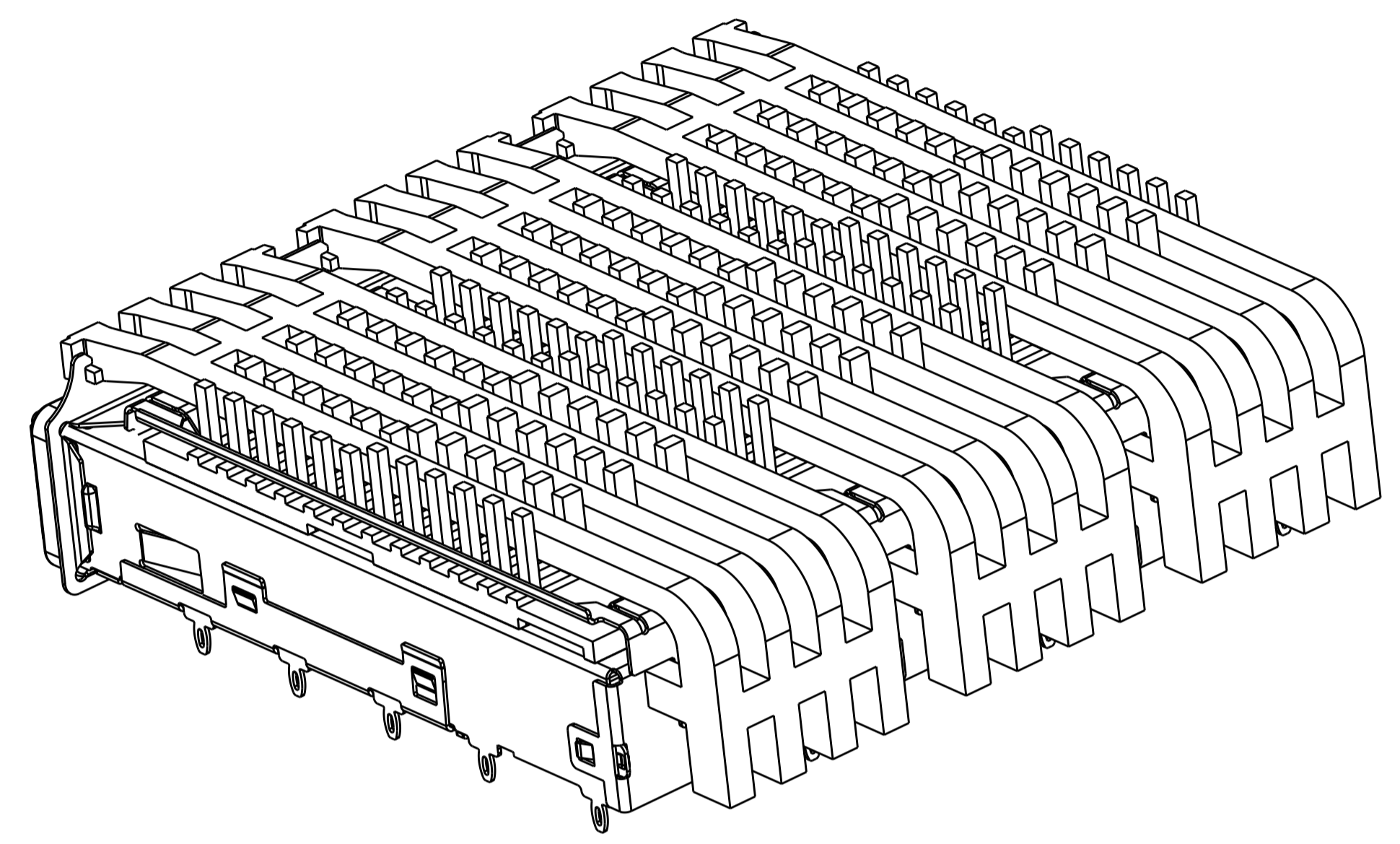

2170507-1 AS SHOWN  
SCALE 3:1

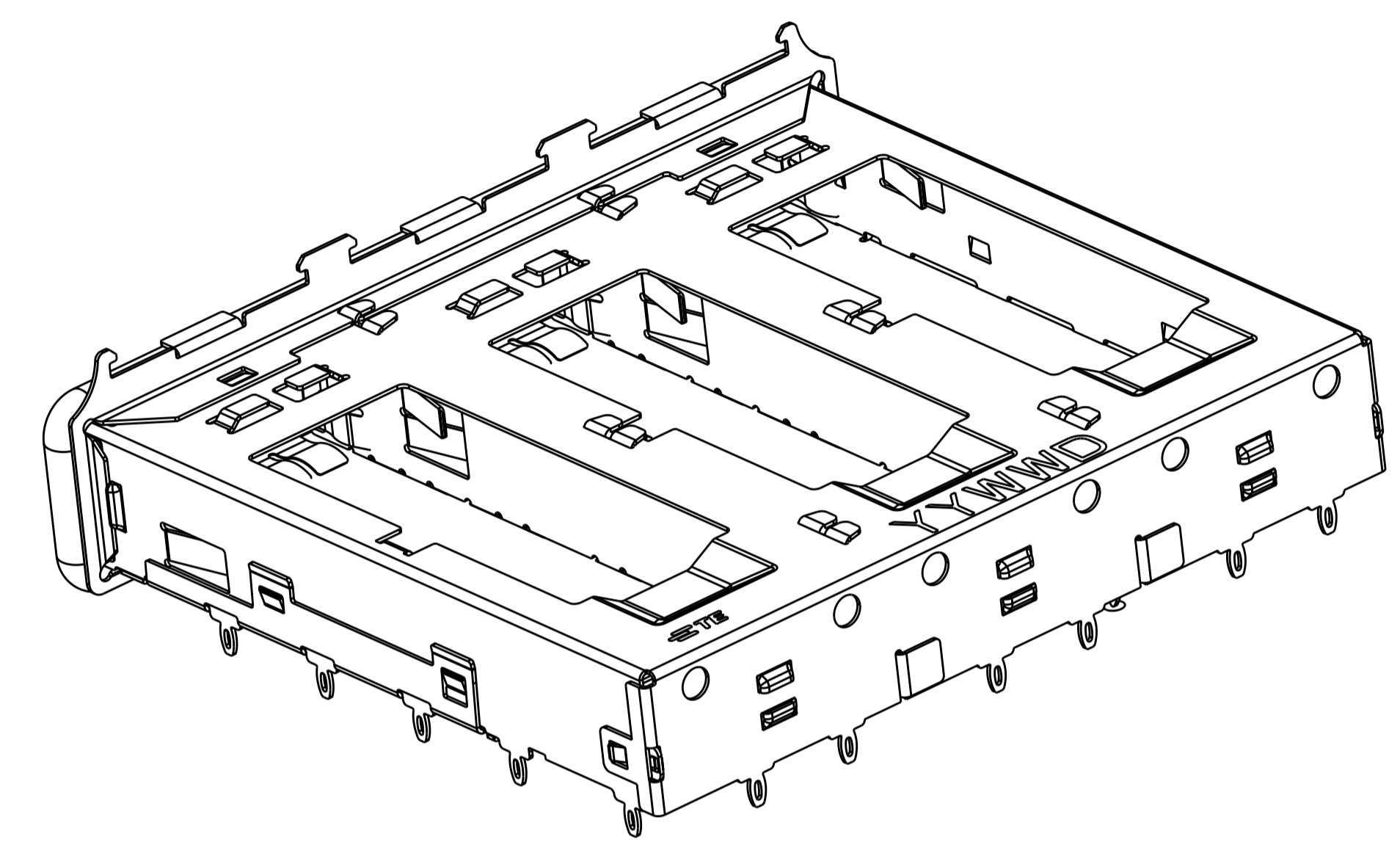

2170507-2 AS SHOWN  
SCALE 3:1

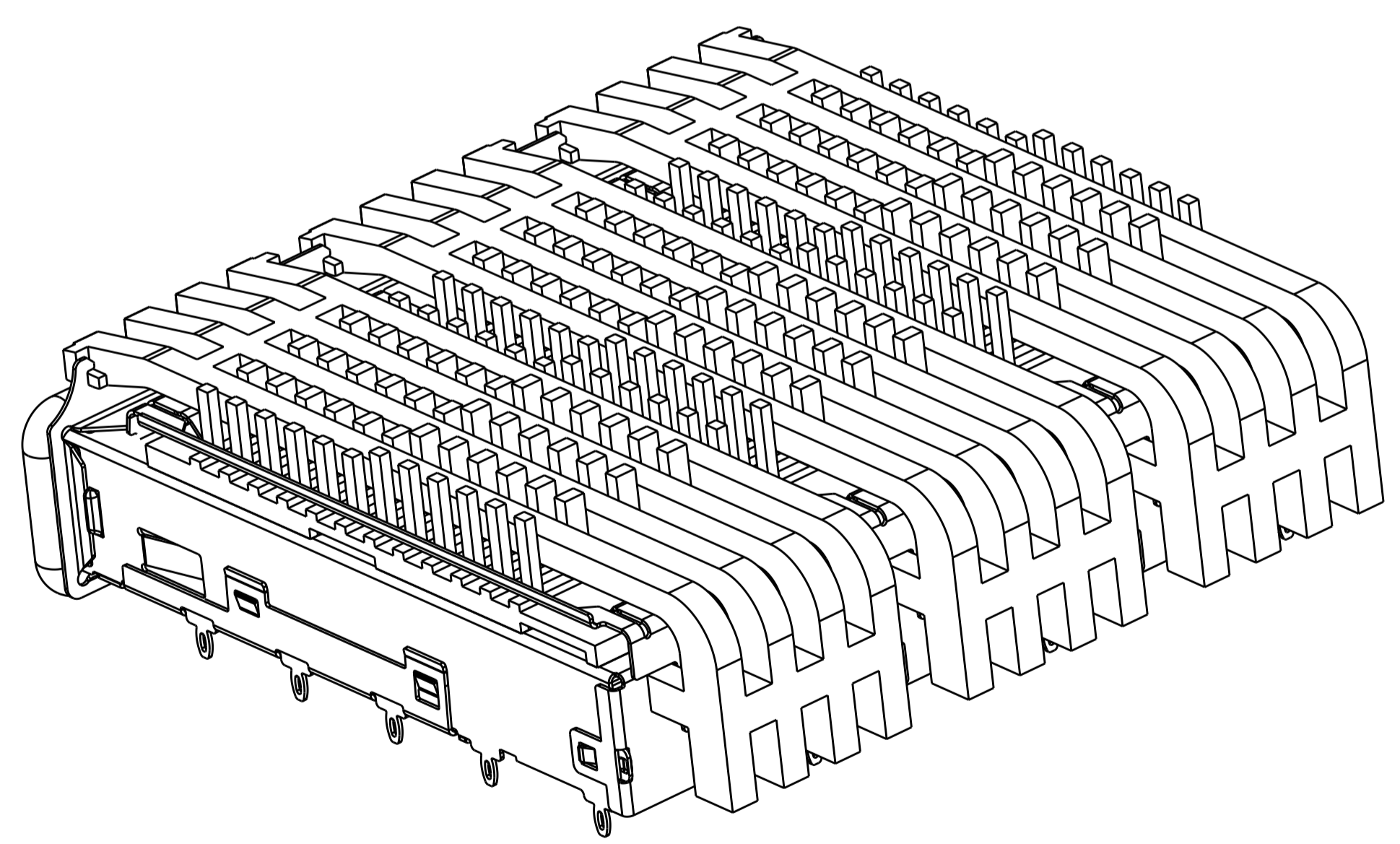

2170507-3 AS SHOWN  
SCALE 3:1

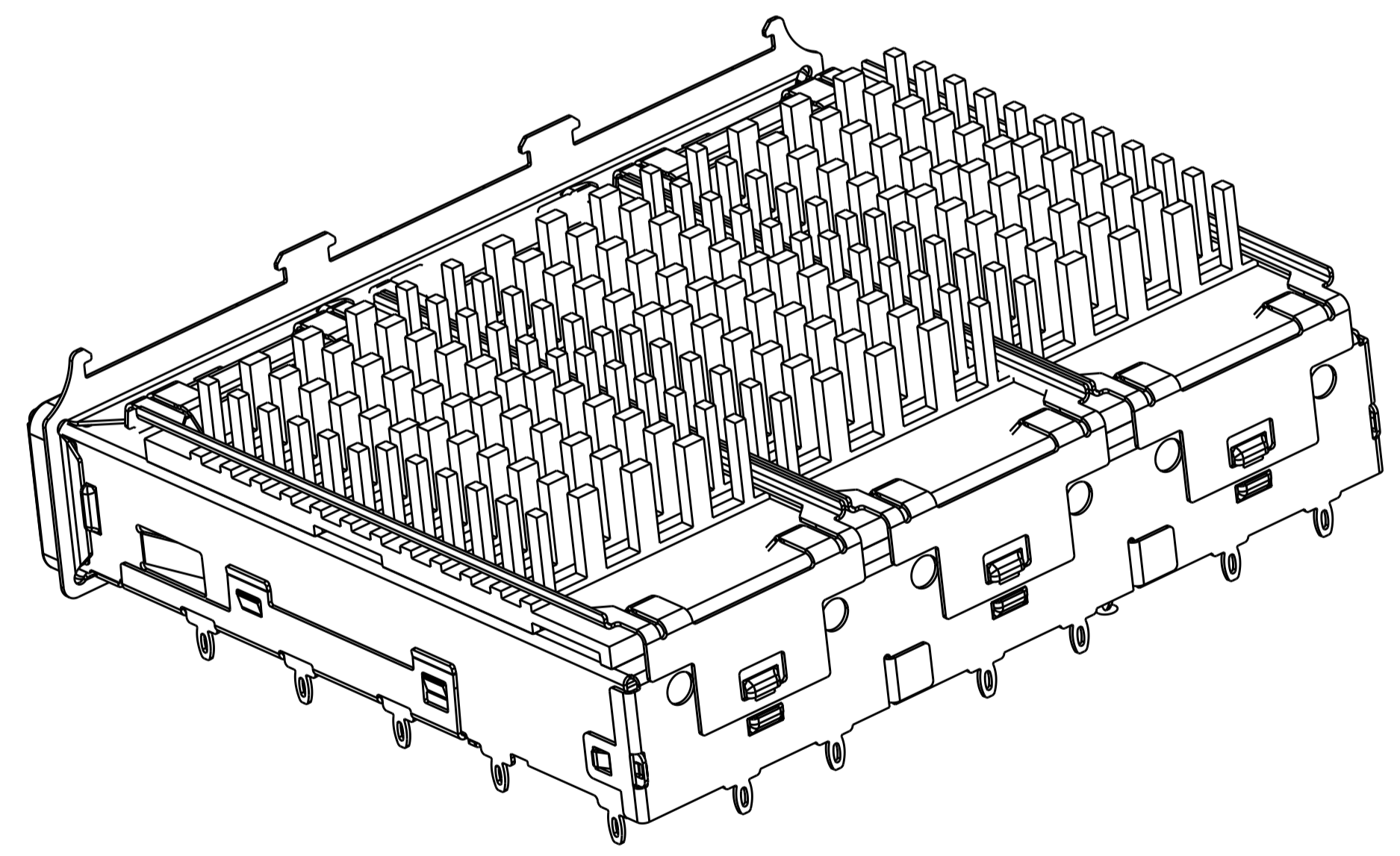

2170507-4 AS SHOWN  
SCALE 3:1

THIS DRAWING IS A CONTROLLED DOCUMENT.		DWN	TIM XUE	27MAR2013	TE Connectivity
DIMENSIONS:		CHK	ALEX CAI	27MAR2013	
mm		APVD	ALEX CAI	27MAR2013	
0 PLC ± 1 PLC ±0.35 2 PLC ±0.25 3 PLC ± 4 PLC ± ANGLES ± FINISH ±		NAME 1X3 CAGE ASSEMBLY, THRU BEZEL W/ELASTOMERIC GASKET AND HEAT SINKS QSFP			
MATERIAL		PRODUCT SPEC	108-2286		SIZE
		APPLICATION SPEC	114-13217		CAGE CODE
		WEIGHT	-		DRAWING NO
		CUSTOMER DRAWING	A100779		SCALE
			C=2170507		SHEET
					5
					OF
					6
					REV
					A

LOC		DIST		REVISIONS			
P.	LTN	DESCRIPTION	DATE	DWN	APVD		
-	-	SEE SHEET 1	-	-	-		

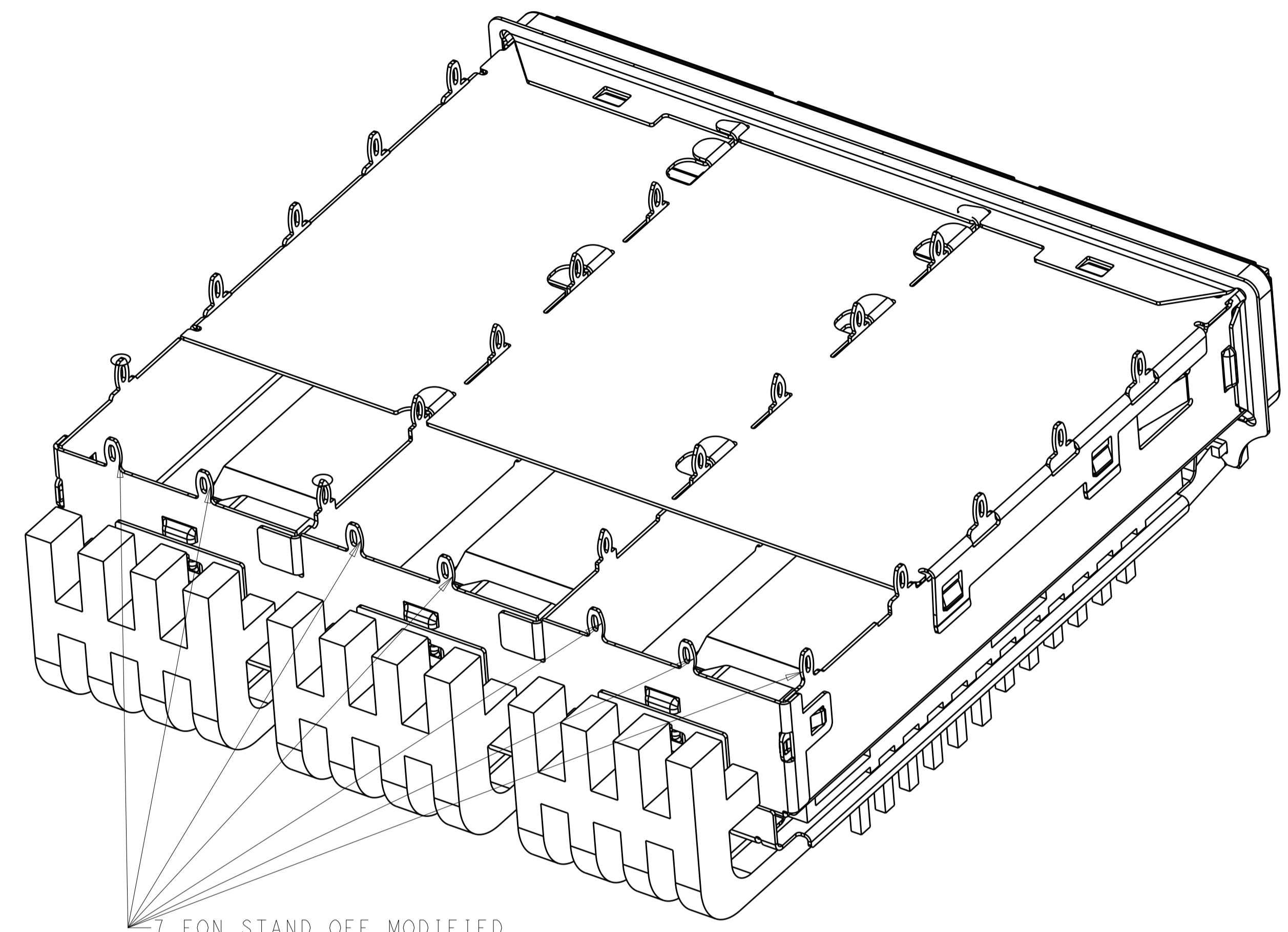

7 EON STAND OFF MODIFIED AS DETAIL D SCALE 4:1

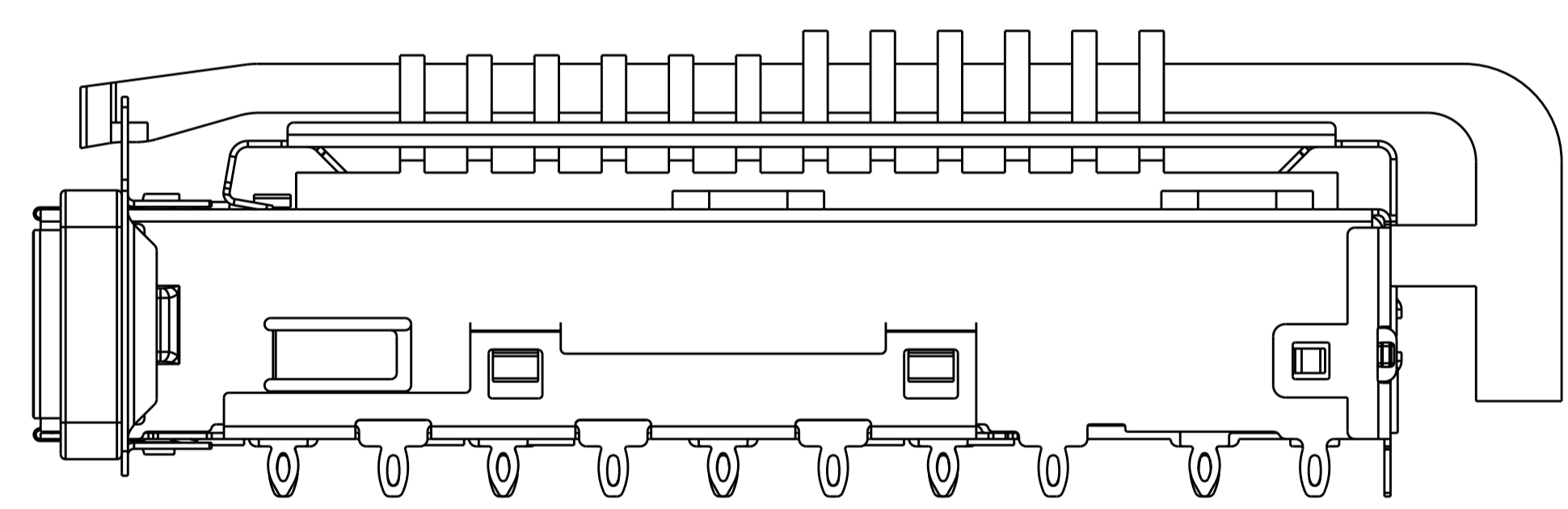

SCALE 4:1

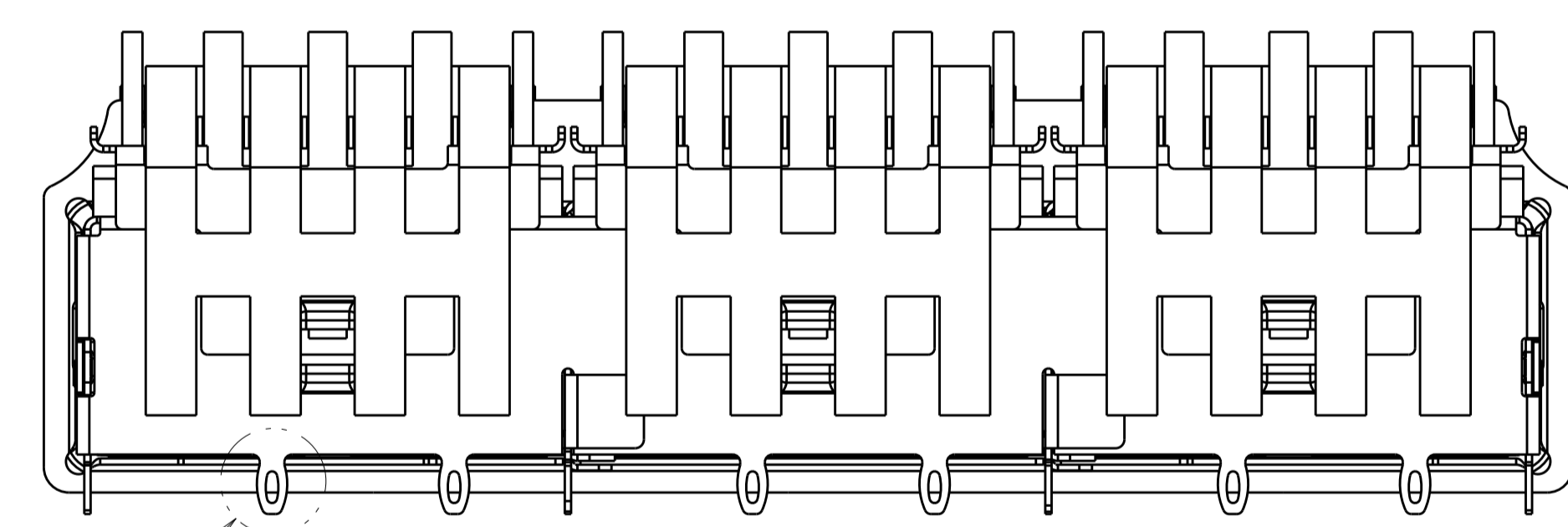

SEE DETAIL D

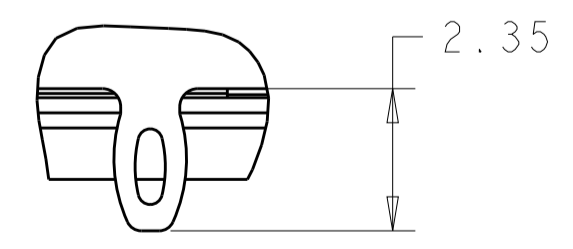

DETAIL D SCALE 8:1

EXCEPT 7 EON STAND OFF MODIFICATION THE OTHER FEATURES ARE SAME WITH 2170507-1

SOLID, SQUARE GASKET		WITH LP	WITH HS	2170507-5
GASKET		LIGHT PIPE	HEAT SINK	PART NUMBER
THIS DRAWING IS A CONTROLLED DOCUMENT.		DWN TIM XUE 27MAR2013	TE Connectivity	
DIMENSIONS:		CHK ALEX CAI 27MAR2013		
TOLERANCES UNLESS OTHERWISE SPECIFIED:		APVD ALEX CAI 27MAR2013	NAME 1X3 CAGE ASSEMBLY, THRU BEZEL W/ELASTOMERIC GASKET AND HEAT SINKS QSFP	
mm	0 PLC ±	PRODUCT SPEC	SIZE CAGE CODE DRAWING NO	
	1 PLC ±0.35	108-2286	A100779C=2170507	
	2 PLC ±0.25	APPLICATION SPEC	RESTRICTED TO	
	3 PLC ±	114-13217	-	
	4 PLC ±	WEIGHT	-	
	ANGLES ±	CUSTOMER DRAWING	SCALE 1:1 SHEET 6 OF 6 REV A	
	FINISH			

## Looking for pricing, stock, or lifecycle information?

Click below to explore more details on WIN SOURCE:

 [View 2170507-1](#) on WIN SOURCE

 [TE Connectivity](#) Information

## Optimize Your Supply Chain with WIN SOURCE Solutions

-  Global Sourcing Solution
-  Obsolete Management
-  Cost Control Management
-  Shortage Management
-  Alternative Solution
-  Excess Inventory Management