

# Datasheet of SAW Filter

## 1411 Band41 TRx

KYOCERA Part No. : SF14-2593M5UUB1

KYOCERA CORPORATION  
All rights reserved

### Rating

Items	Rating	Unit	Note
Operating Temperature Range	-20 to +85	deg.C	
Storage Temperature Range	-40 to +85	deg.C	
Max Input Power (TRx port)	+33	dBm	5,000Hours, Ta=50deg.C, DFT-s-OFDM
	+31.5	dBm	5,000Hours, Ta=50deg.C, CP-OFDM
TRx Port Nominal Impedance	50//1.2pF,+2.3nH	ohm	Unbalance
Ant. Port Nominal Impedance	50//1.0pF,+2.9nH	ohm	Unbalance

### Dimensions

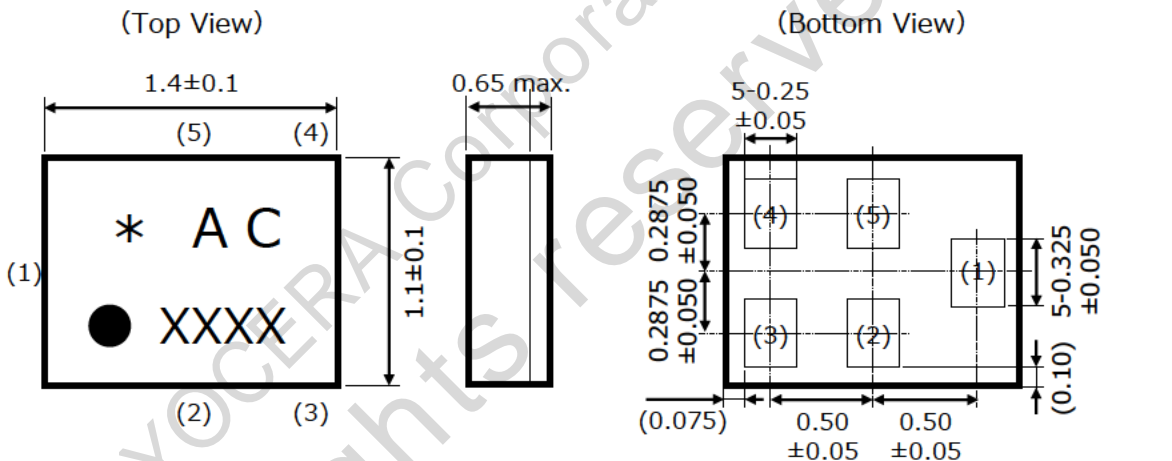

- \* : Identification mark
- AC : Identification no.
- : Index mark of pin 1
- XXXX : Production code

Pin No.	Function
(1)	Input(TRx)
(4)	Output(Ant.)
Others	GND

### Recommendable Land Pattern

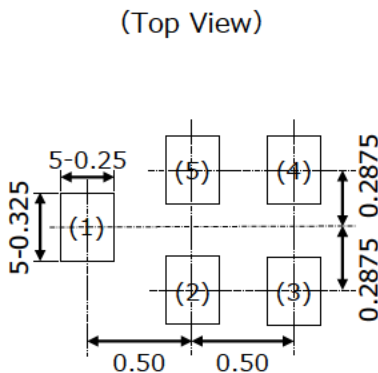

### Measurement Circuit

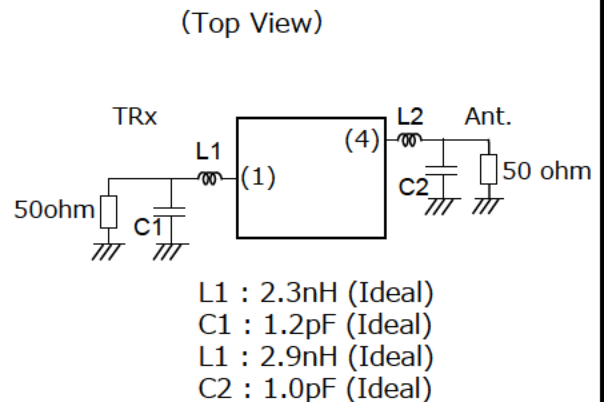

## Electrical Characteristics

Items	frequency (MHz)	Characteristics			Unit	Notes
		min.	Typ.	max.		
Nominal Center Frequency	-	2593			MHz	
Insertion Loss	2496 to 2500	-	1.7	2.4	dB	
	2500 to 2515	-	1.5	2.3	dB	
	2515 to 2545	-	1.2	2.2	dB	
	2545 to 2575	-	1.0	2.2	dB	
	2575 to 2690	-	1.5	2.2	dB	
Input VSWR(TRx)	2496 to 2690	-	1.3	2.0	-	
Output VSWR(Ant)	2496 to 2690	-	1.3	2.0	-	
Attenuation	617 to 960	25	28	-	dB	LB
	1166.22 to 1254	25	28	-	dB	GPS L5+L2
	1559.052 to 1605.89	27	33	-	dB	GPS L1
	1710 to 1785	23	35	-	dB	B3 Tx
	1805 to 1880	16	27	-	dB	B3 Rx
	1880 to 1920	13	24	-	dB	B39
	1920 to 1990	8	19	-	dB	B1 Tx
	2110 to 2170	2	10	-	dB	B1 Rx
	2300 to 2400	4	8	-	dB	B40
	2402 to 2462	25	32	-	dB	WiFi CH1-9,Ave.for 19MHzBW
	2447 to 2467	19	32	-	dB	WiFi CH10,Ave.for 19MHzBW
	2452 to 2472	12	28	-	dB	WiFi CH11,Ave.for 19MHzBW
	2457 to 2477	7	19	-	dB	WiFi CH12,Ave.for 19MHzBW
	2462 to 2482	4	12	-	dB	WiFi CH13,Ave.for 19MHzBW
	3300 to 3800	17	22	-	dB	n78
	3800 to 4200	16	20	-	dB	n77
	4400 to 5000	10	18	-	dB	n79
	4992 to 5380	24	28	-	dB	2fo
5150 to 5850	25	33	-	dB	WiFi 5G	
7488 to 8070	25	48	-	dB	3fo	

### Electrical Characteristics

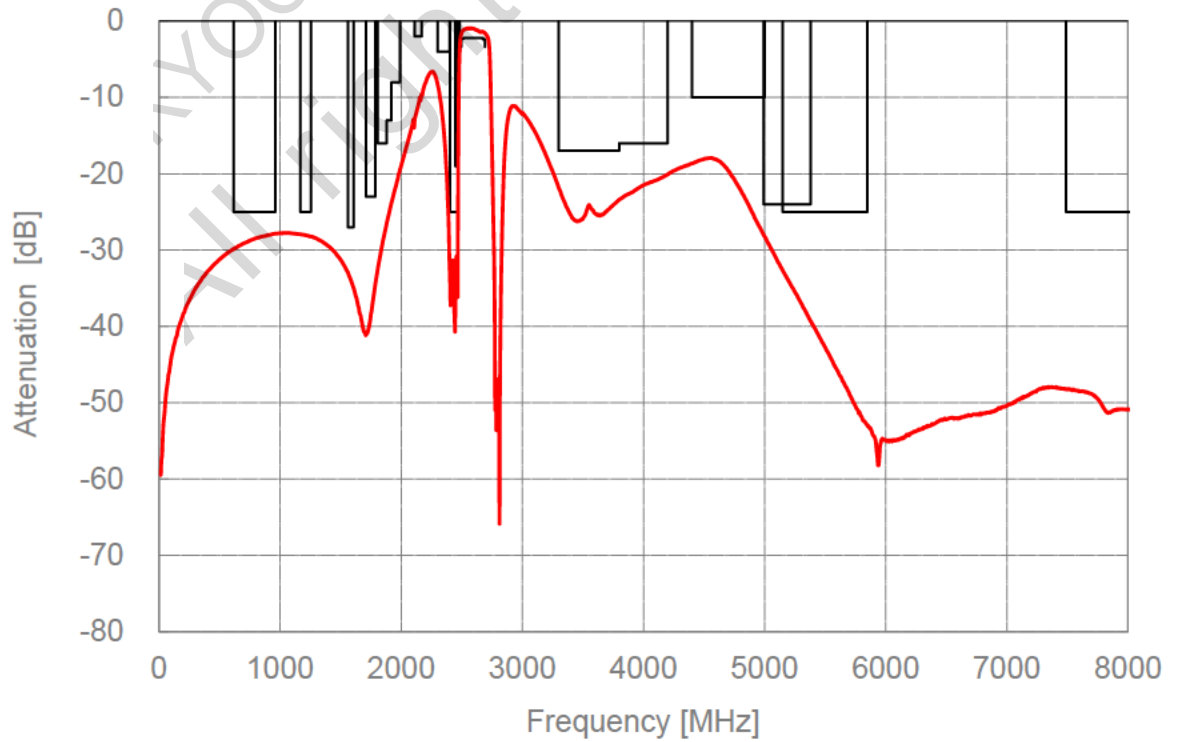
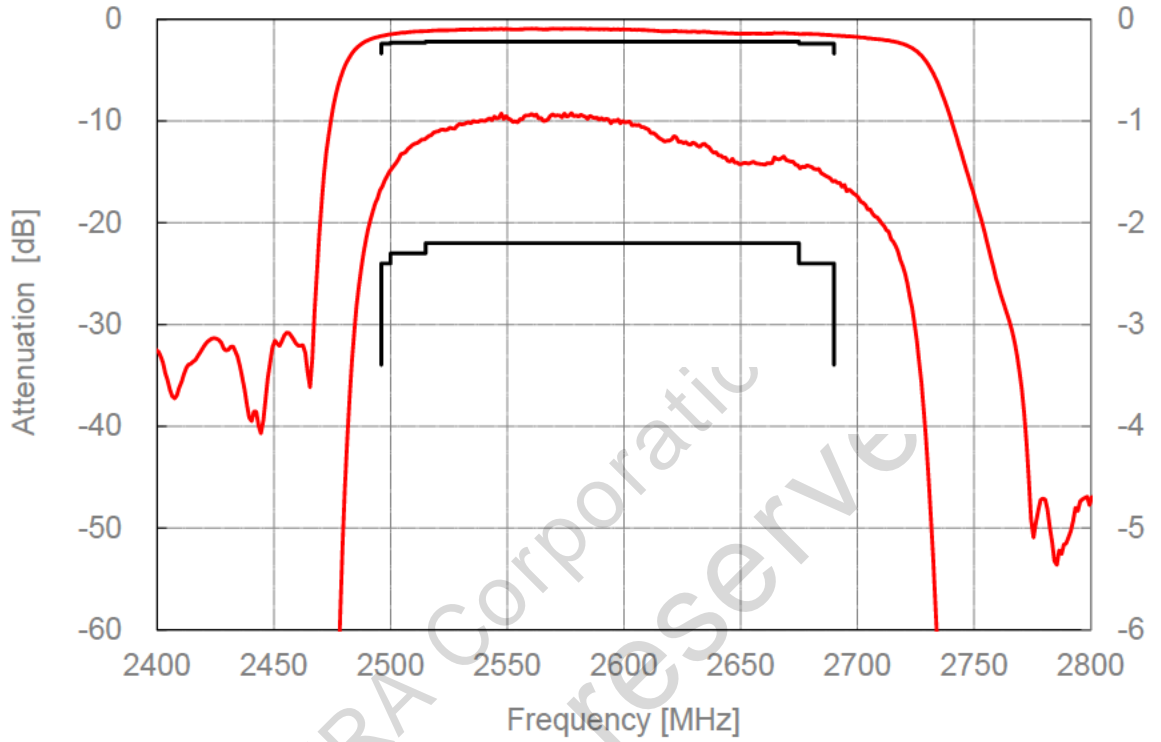

**Electrical Characteristics**

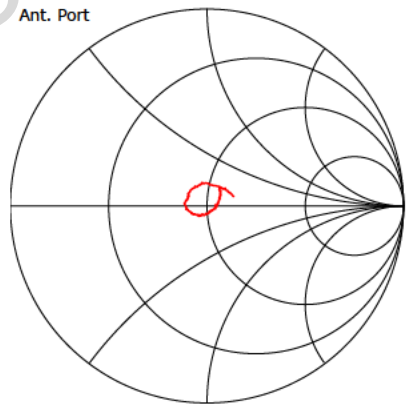
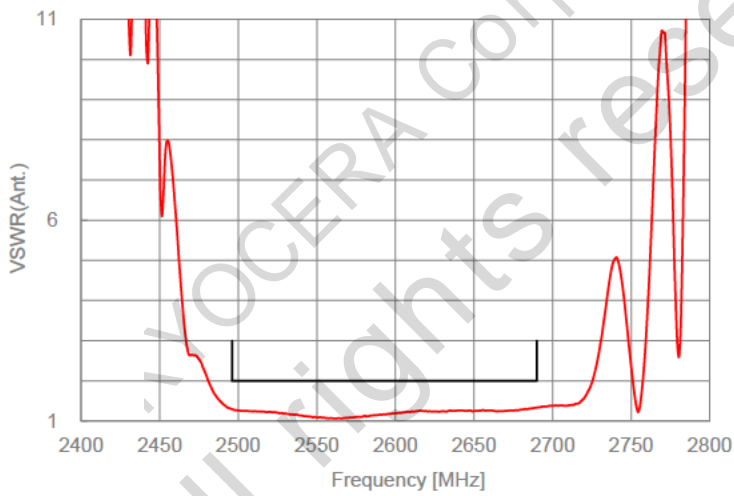
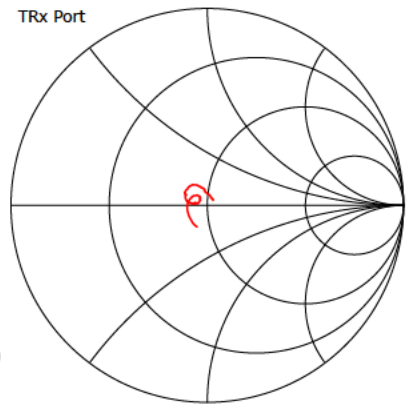
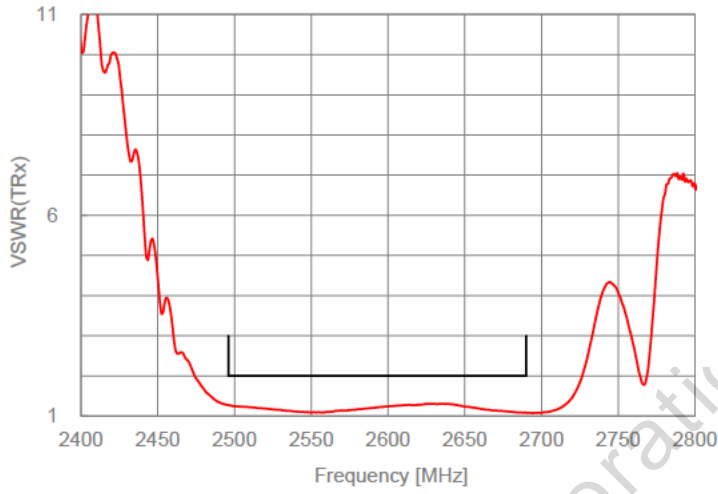

### Tape & Reel Specification

#### [Tape]

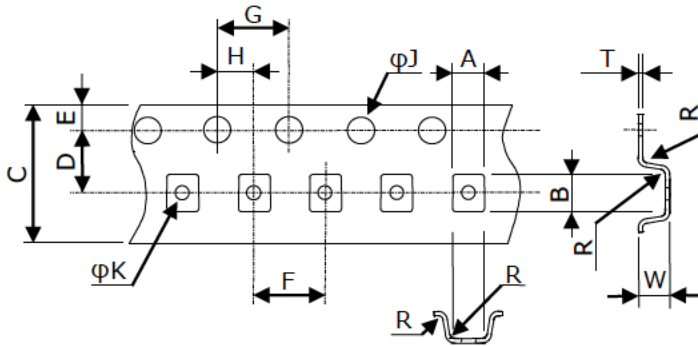

Unit : mm

Part	Dimension
A	1.30±0.05
B	1.60±0.05
C	8.00±0.15
D	3.50±0.05
E	1.75±0.10
F	4.0±0.1
G	4.0±0.1
H	2.00±0.05
φJ	1.5+0.1/-0
φK	0.5±0.1
R	0.2 Max
W	0.70±0.05
T	0.20±0.05

W : Dimension is depth of pockets.

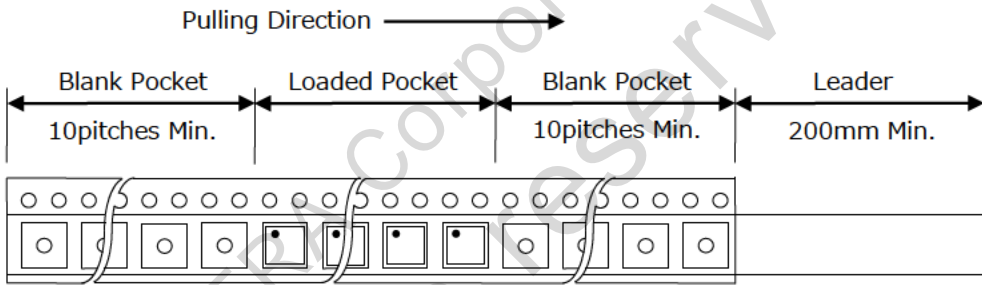

#### [Reel]

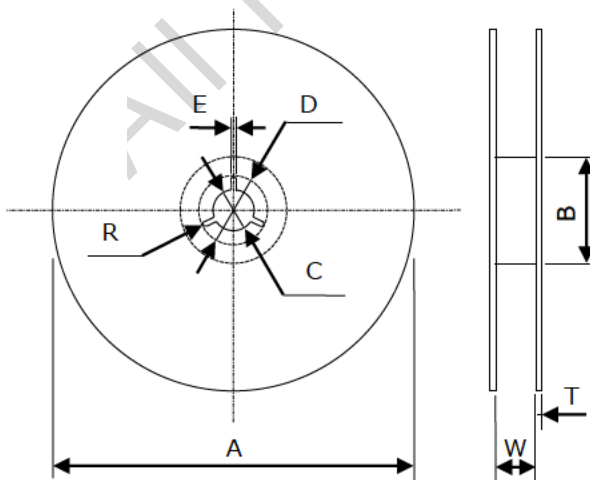

Unit : mm

Part	Dimension
A	178 ± 2
B	60 ± 2
C	13.0 ± 0.2
D	21.0 ± 0.8
E	2.0 ± 0.5
R	1
W	9.5 ± 1.0
T	2.0 ± 0.2

## Notice

1. Characteristics described in this datasheet are for references specifications shall be based on written documents agreed by each party.
2. Contents in this datasheet are subject to change without notice. It is recommended to confirm the latest information at the time of usage. Also, this datasheet is revised once a year. We may not be able to accept requests based on old datasheets.
3. Products in this datasheet are intended to be used in general electronic equipment such as office equipment, audio and visual equipment, communication equipment, measurement instrument and home appliances. It is absolutely recommended to consult with our sales representatives in advance upon planning to use our products in applications which require extremely high quality and reliability such as aircraft and aerospace equipment, traffic systems, safety systems, power plant and medical equipment including life maintenance systems.
4. Even though we strive for improvements of quality and reliability of products, it is requested to design with enough safety margin in equipment or systems in order not to threaten human lives directly or damage human bodies or properties by an accidental result of products.
5. It is requested to design based on guaranteed specifications for such as maximum ratings, operating voltage and operating temperature. It is not the scope of our guarantee for unsatisfactory results due to misuse or inadequate usage of products in the datasheet.
6. Operation summaries and circuit examples in this datasheet are intended to explain typical operation and usage of the product. It is recommended to perform circuit and assembly design considering surrounding conditions upon using products in this datasheet.
7. Technical information described in this datasheet is meant to explain typical operations and applications of products, and it is not intended to guarantee or license intellectual properties or other industrial rights of the third party or Kyocera.
8. Trademarks, logos and brand names used in this datasheet are owned by Kyocera or the corresponding third party.
9. Certain products in this datasheet are subject to the Foreign Exchange and Foreign Trade Control Act of Japan, and require the license from Japanese Government upon exporting the restricted products and technical information under the law. Besides, it is requested not to use products and technical information in the datasheet for the development and/or manufacture of weapons of mass destruction or other conventional weapons, nor to provide them to any third party with the possibility of having such purposes.
10. It is prohibited to reprint and reproduce a part or whole of this datasheet without permission.

## Looking for pricing, stock, or lifecycle information?

Click below to explore more details on WIN SOURCE:

- ⊖ [View SF14-2593M5UUB1 on WIN SOURCE](#)
- ⊖ [Kyocera International Inc. Electronic Components Information](#)

## Optimize Your Supply Chain with WIN SOURCE Solutions

- ✓ Global Sourcing Solution
- ✓ Obsolete Management
- ✓ Cost Control Management
- ✓ Shortage Management
- ✓ Alternative Solution
- ✓ Excess Inventory Management