

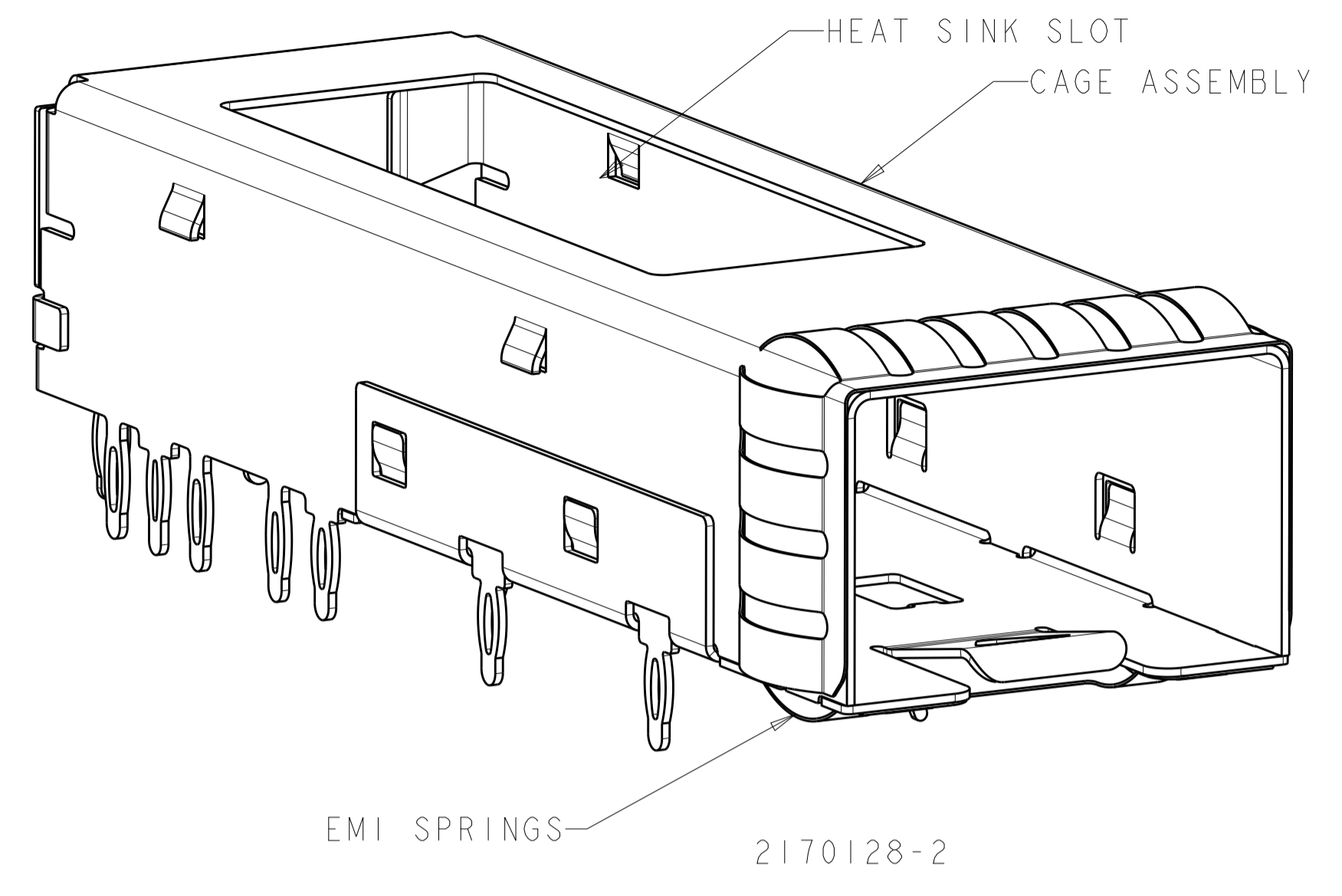

**THE DATASHEET OF**  
**2170128-1**

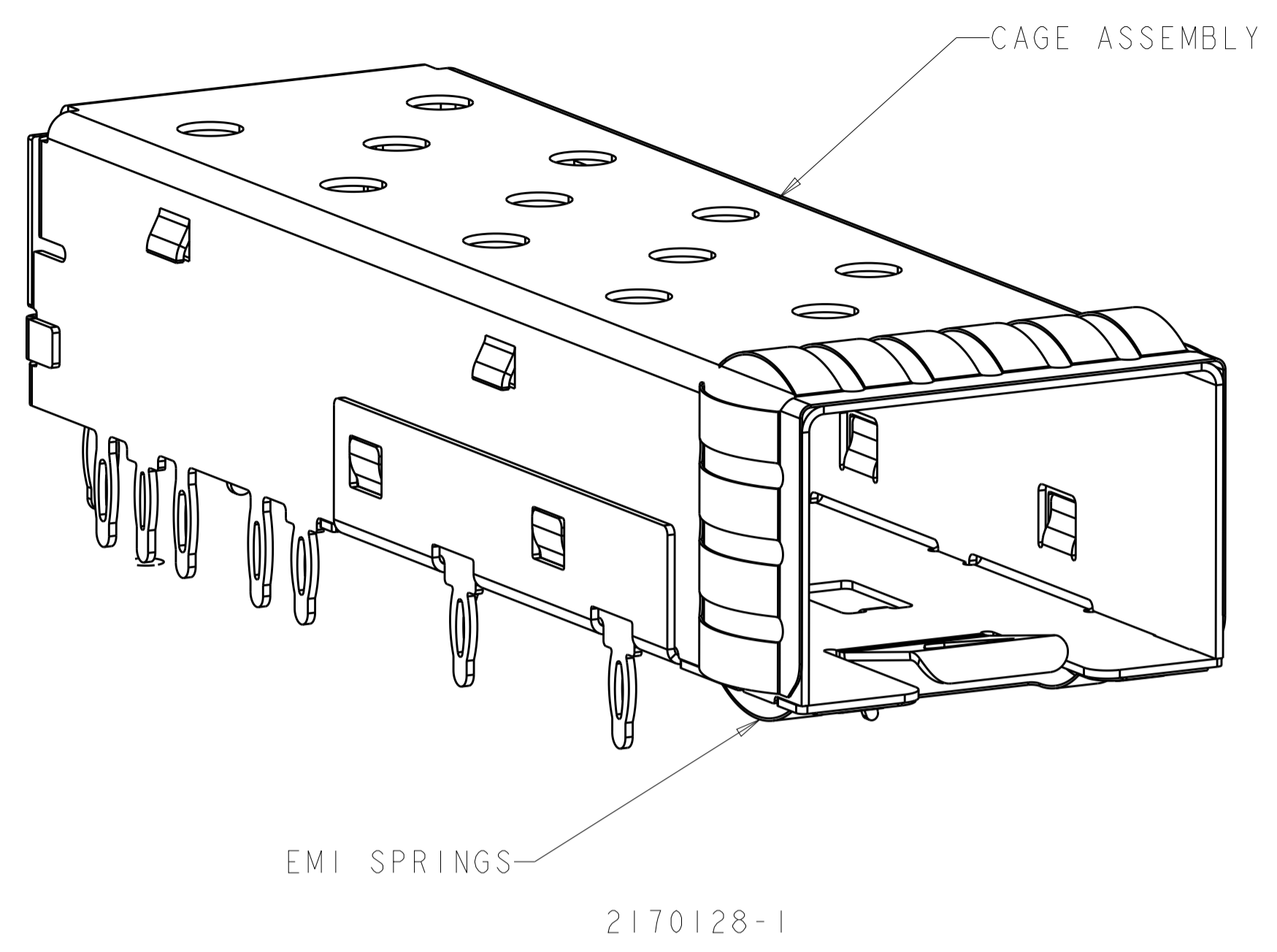

LOC	DIST	REVISIONS			
P	LTN	DESCRIPTION	DATE	DMN	APVD
GP	00				
	A	RELEASED PER ECO-13-007850	09MAY2013	PP	SH
	A1	RELEASED PER ECO-13-015033	24SEP2013	JZ	SH
	A2	REVISED PER ECR-18-019121	28MAR2019	IT	SH



- ⚠ MATERIAL:  
CAGE ASSEMBLY - NICKEL-SILVER ALLOY.  
EMI SPRINGS - COPPER ALLOY.
- ⚠ FINISH:  
EMI SPRINGS - 0.8-2um NICKEL PLATE  
NON-PLATED EDGES PERMISSIBLE.
- 3. MATES WITH SFP MSA COMPLIANT TRANSCEIVERS.
- ⚠ PADS AND VIAS CHASSIS GROUND.
- ⚠ DATUM AND BASIC DIMENSION ESTABLISHED BY CUSTOMER.
- 6. MINIMUM PC BOARD THICKNESS:  
SINGLE SIDED = 1.50 mm
- ⚠ REFERENCE APPLICATION SPEC. 114-13120, HOLE A, FOR  
RECOMMENDED DRILL HOLE DIAMETER AND PLATING  
THICKNESS.
- ⚠ REFERENCE APPLICATION SPEC. 114-13120, HOLE C, FOR  
RECOMMENDED DRILL HOLE DIAMETER AND PLATING  
THICKNESS.

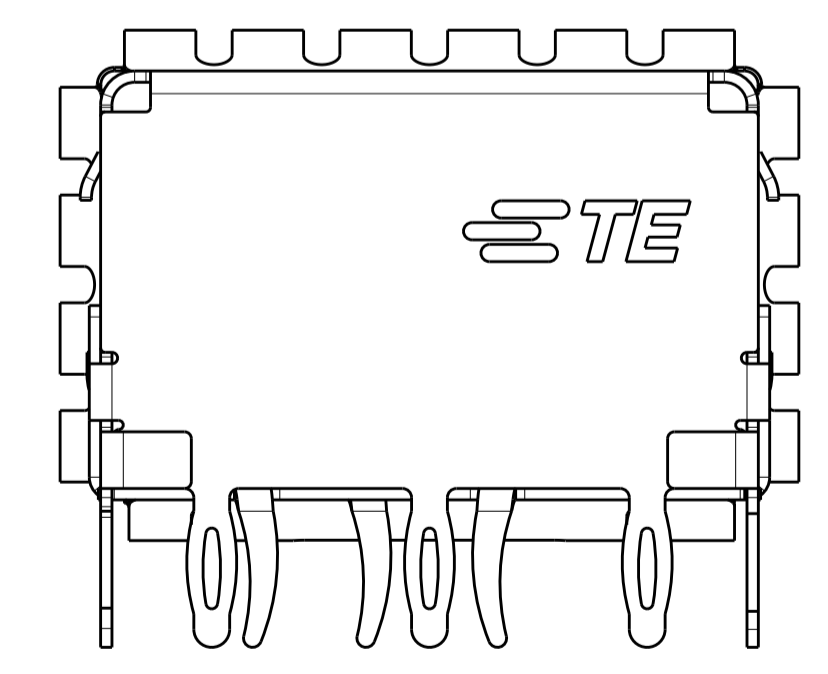
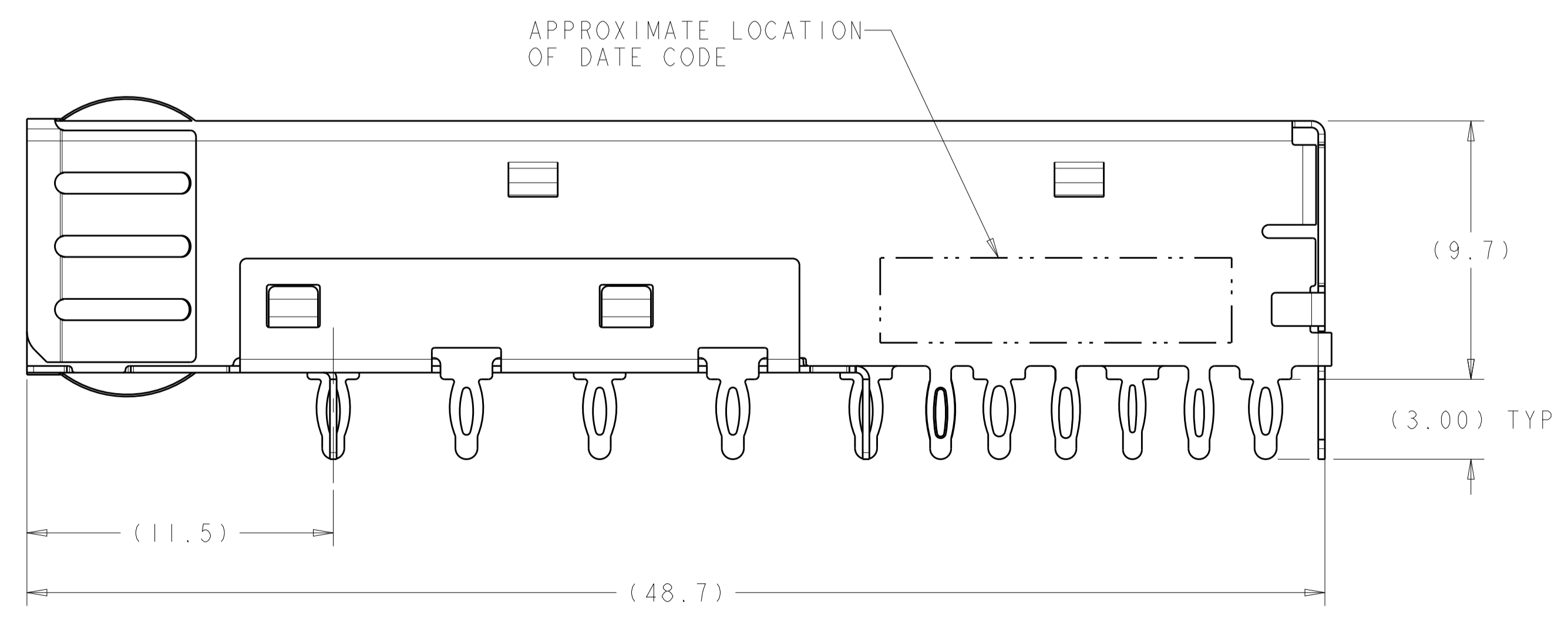
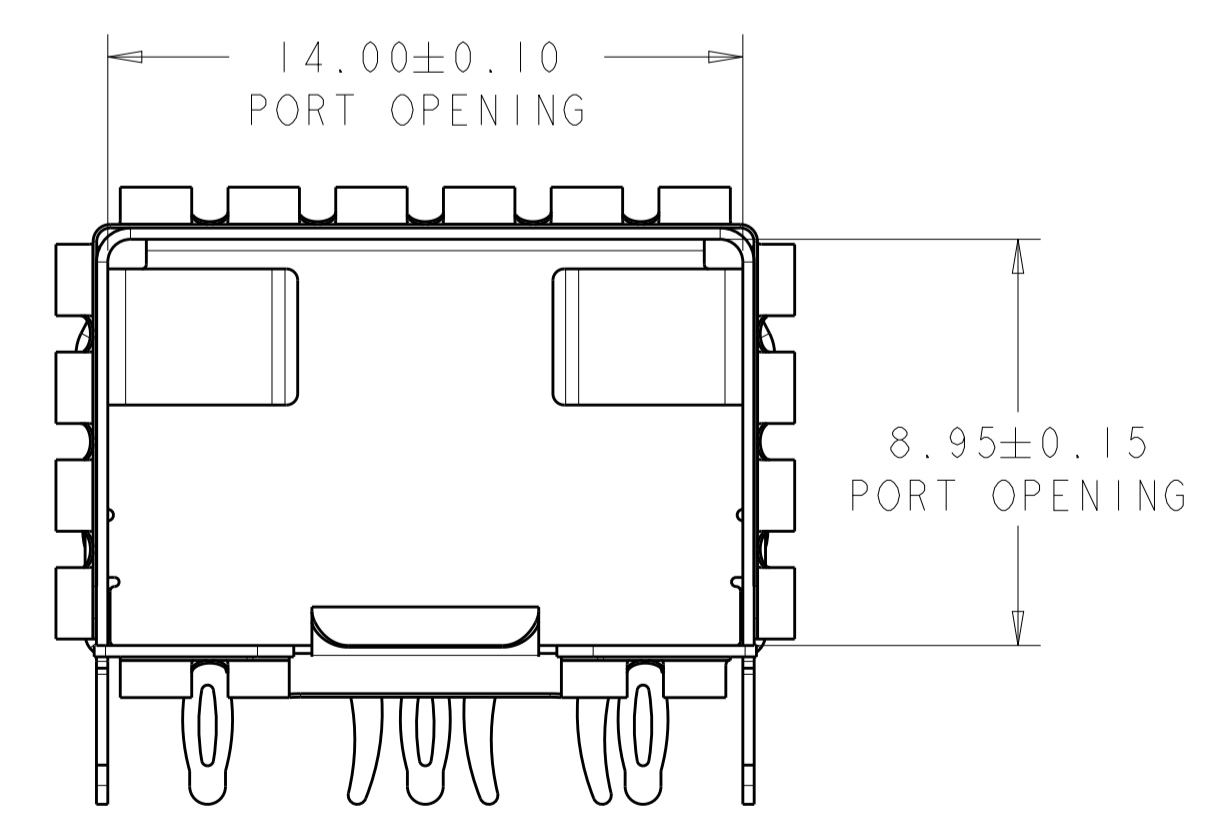
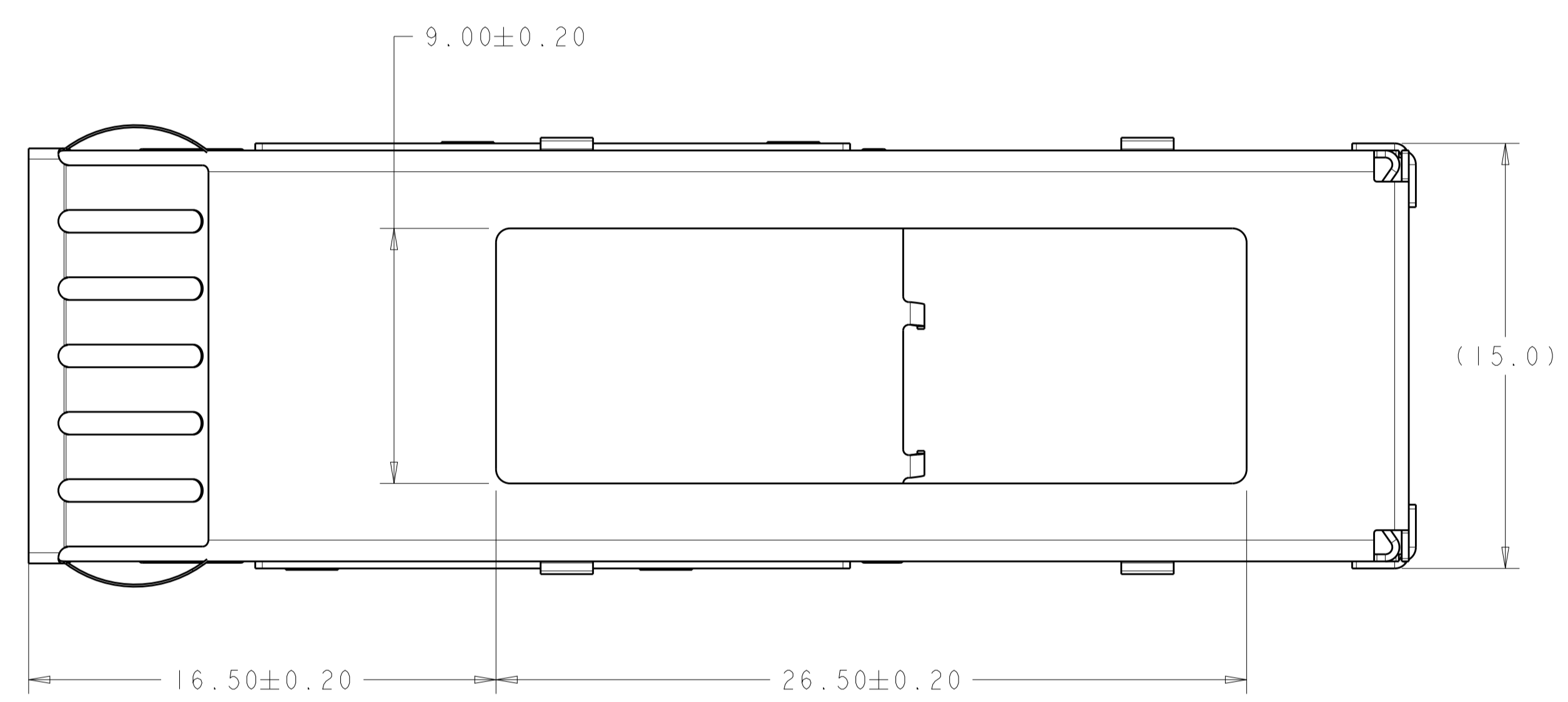

WITH HEAT SINK SLOT	2170128-2
WITHOUT HEAT SINK SLOT	2170128-1
DESCRIPTION	PART NUMBER

THIS DRAWING IS A CONTROLLED DOCUMENT.		DMN TIM XUE 30AUG2011	 TE Connectivity
DIMENSIONS:		CHK C. WANG 30AUG2011	
mm	TOLERANCES UNLESS OTHERWISE SPECIFIED:	APVD C. WANG 30AUG2011	NAME SFP+ 1X1 CAGE ASSEMBLY PRESS-FIT, EXTERNAL EMI SPRINGS
0 PLC ±0.25	1 PLC ±0.20	PRODUCT SPEC 108-2364	SIZE 114-13120
2 PLC ±0.20	3 PLC ±0.15	APPLICATION SPEC 114-13120	RESTRICTED TO
4 PLC ±0.15	ANGLES ±0.15	WEIGHT	A100779C=2170128
MATERIAL	FINISH	Customer Drawing	SCALE 6:1 SHEET 1 OF 2 REV A2

LOC	DIST	REV	DATE	BY	APPD
GP	00				

REVISIONS			
NO	DESCRIPTION	DATE	BY
-	SEE SHEET 1	-	-

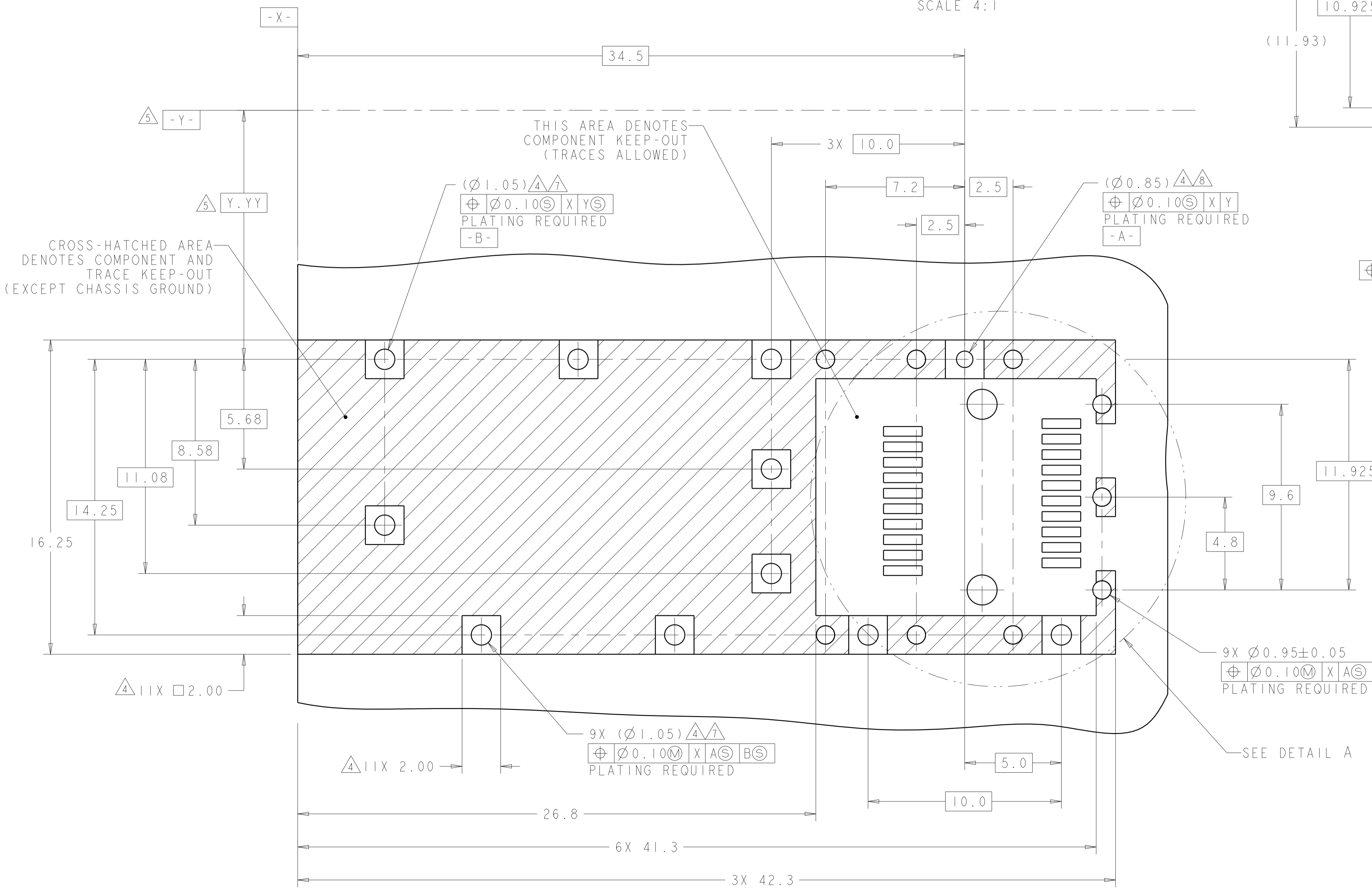
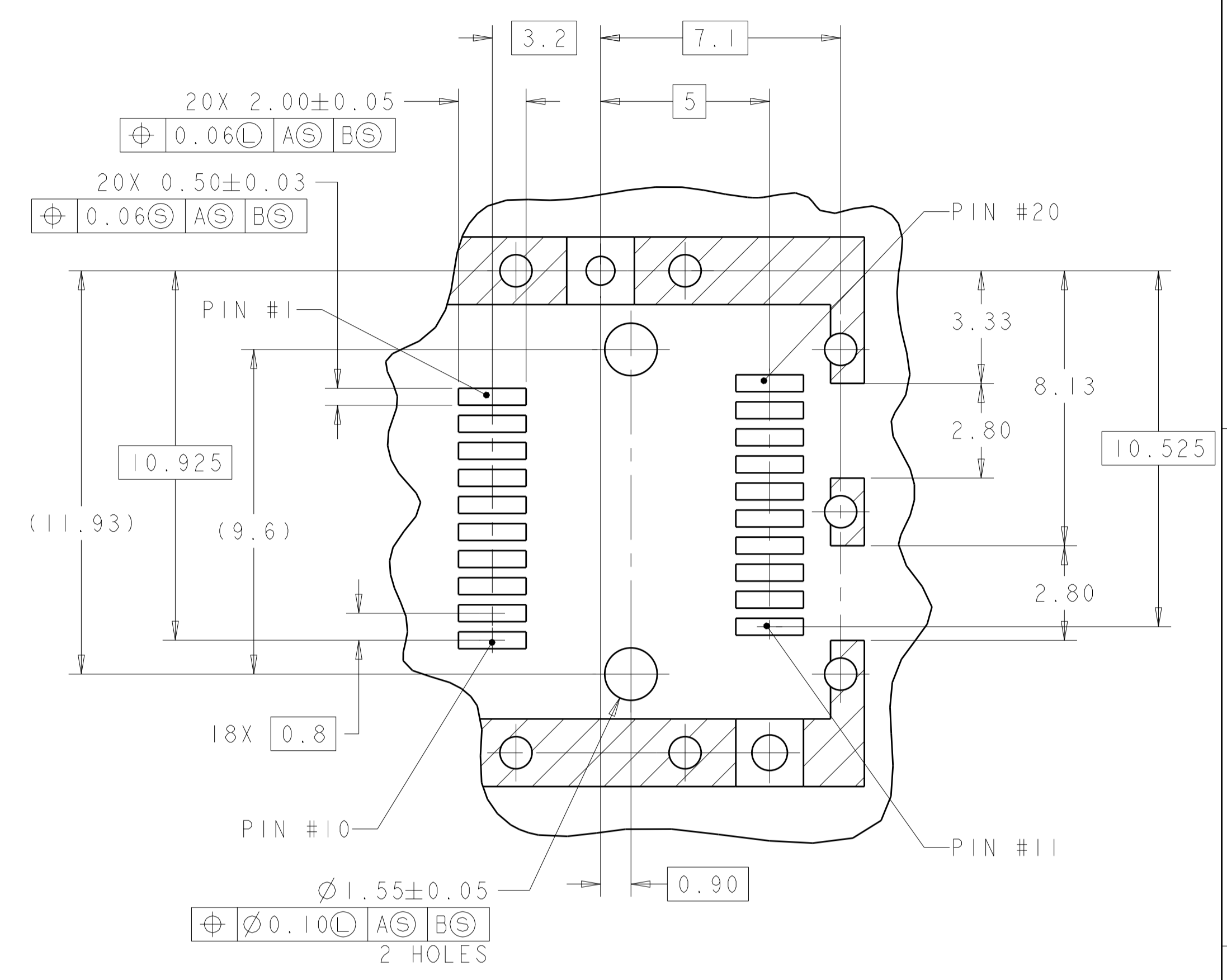
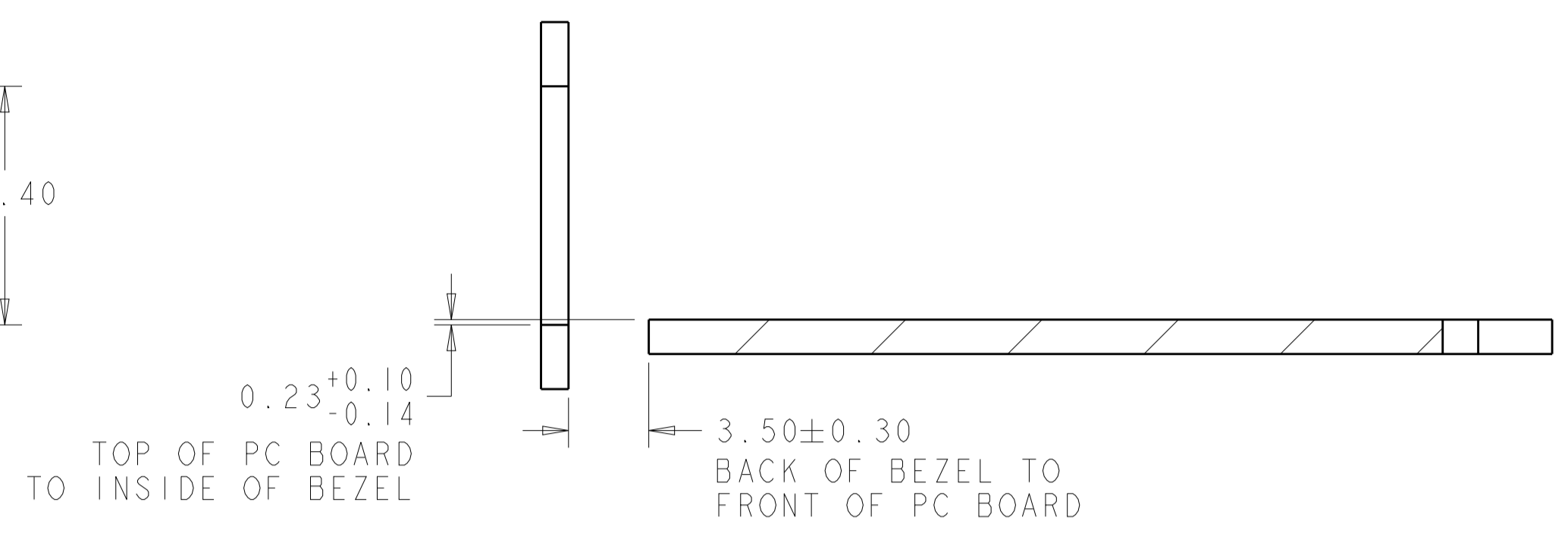
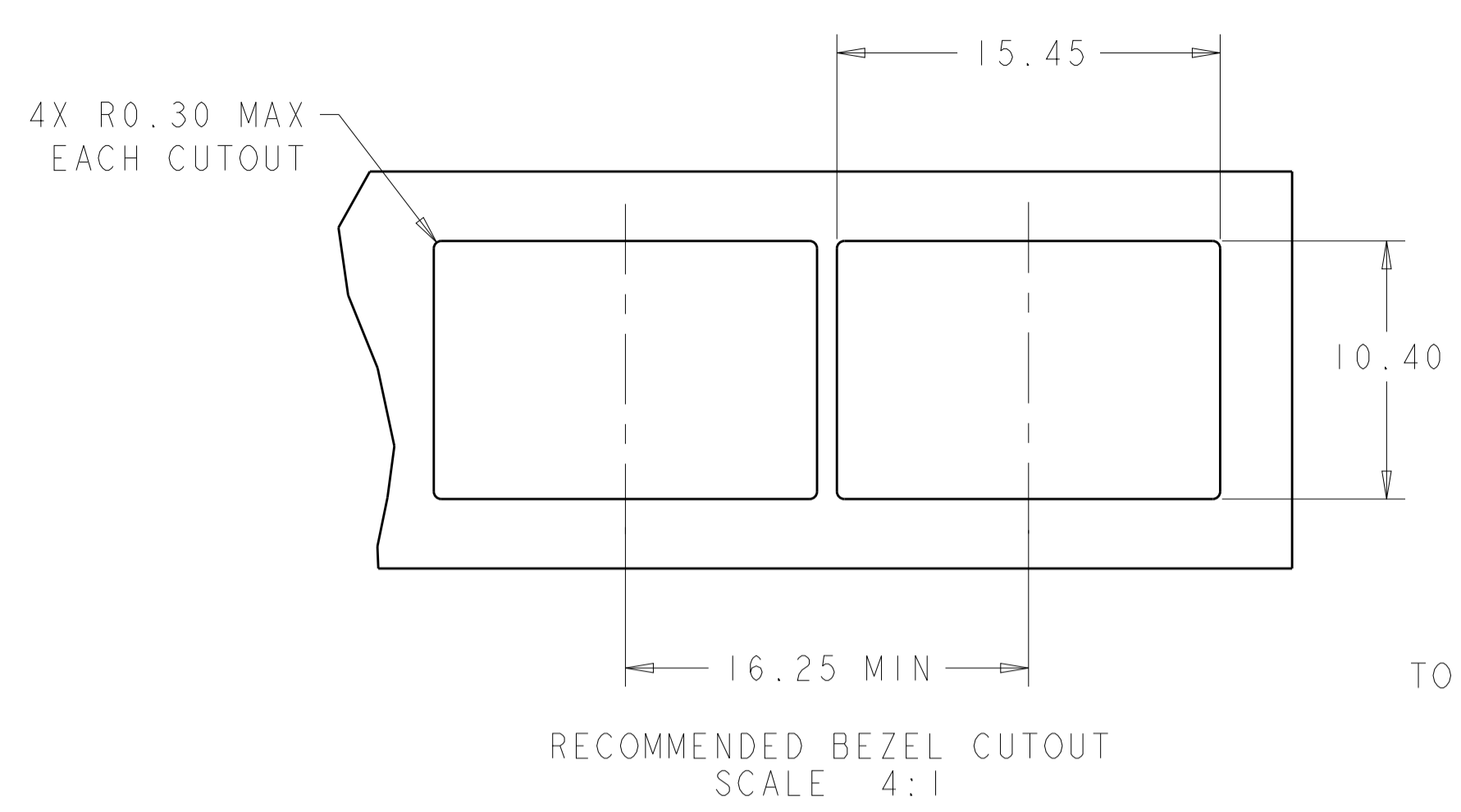

THIS DRAWING IS A CONTROLLED DOCUMENT.		OWN: TIM XUE 30AUG2011	 TE Connectivity
DIMENSIONS: mm		CHK: C. WANG 30AUG2011	
TOLERANCES UNLESS OTHERWISE SPECIFIED:		APVD: C. WANG 30AUG2011	
0 PLC ± 1 PLC ±0.25 2 PLC ±0.20 3 PLC ±0.15 4 PLC ±0.15 ANGLES ±0.15		NAME: SFP+ 1X1 CAGE ASSEMBLY PRESS-FIT, EXTERNAL EMI SPRINGS	
MATERIAL:	FINISH:	PRODUCT SPEC: 108-2364	SIZE: A1
		APPLICATION SPEC: 114-13120	CAGE CODE: 2170128
		WEIGHT:	RESTRICTED TO:
		Customer Drawing	SCALE: 6:1 SHEET 2 OF 2 REV: A2

## Looking for pricing, stock, or lifecycle information?

Click below to explore more details on WIN SOURCE:

 [View 2170128-1](#) on WIN SOURCE

 [TE Connectivity](#) Information

## Optimize Your Supply Chain with WIN SOURCE Solutions

-  Global Sourcing Solution
-  Obsolete Management
-  Cost Control Management
-  Shortage Management
-  Alternative Solution
-  Excess Inventory Management