



**THE DATASHEET OF  
NSIP8941W1-DSWR**



### Product Overview

The NSiP894x devices are quad-channel digital isolators with integrated isolated DC-DC converter. The isolated DC-DC converter provides up to 500mW output power using on chip transformer. The feedback PWM signal is sent to primary side by a digital isolator based on Novosense capacity isolation technology. The high integrated solution can help to simplify system design and improve reliability. The NSiP894x device is safety certified by UL1577 support 4.5kVrms withstand voltages, while providing high electromagnetic immunity and low emissions. The data rate of the NSiP894x is up to 150Mbps, and the common-mode transient immunity (CMTI) is up to 150kV/us. The NSiP894x devices provide 5V to 5V, 5V to 3.3V, 3.3V to 3.3V conversion mode, the output voltage can be set by SEL pin. The device can go into standby mode when the PDIS pin set to high, and there is no output voltage at VISO pin.

### Key Features

- Up to 4500Vrms Insulation voltage
- Power supply voltage: 3.3V to 5.5V
- 5V to 5V, 5V to 3.3V, support 100mA load current
- 3.3V to 3.3V, support 60mA load current
- Over current and over temperature protection
- Data rate: DC to 150Mbps
- High CMTI: 150kV/us
- Propagation delay: <15ns
- High system level EMC performance:
  - Enhanced system level ESD, EFT, Surge immunity
- Operation temperature: -40°C~125°C
- RoHS-compliant packages:
  - SOW16

### Safety Regulatory Approvals

- UL recognition: up to 4500V<sub>rms</sub> for 1 minute per UL1577
- CQC certification per GB4943.1-2011
- CSA component notice 5A
- DIN VDE V 0884-11:2017-01

### Applications

- Industrial automation system
- Isolated SPI, RS232, RS485
- General-purpose multichannel isolation

### Device Information

Part Number	Package	Body Size
NSiP894x-DSWR	SOW16	10.30mm × 7.50mm

### Functional Block Diagrams

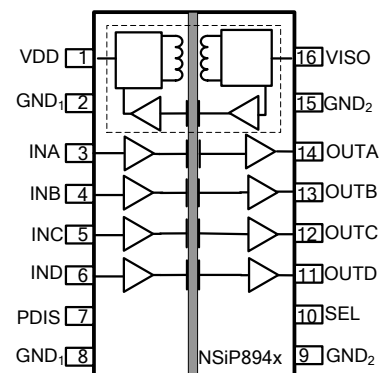

Figure 1. NSiP894x Block Diagram<sup>1</sup>

<sup>1</sup> The isolation channel direction can be either depend on different part number.

## INDEX

<b>1. PIN CONFIGURATION AND FUNCTIONS</b> .....	<b>3</b>
<b>2. ABSOLUTE MAXIMUM RATINGS</b> .....	<b>4</b>
<b>3. RECOMMENDED OPERATING CONDITIONS</b> .....	<b>5</b>
<b>4. THERMAL CHARACTERISTICS</b> .....	<b>5</b>
<b>5. SPECIFICATIONS</b> .....	<b>5</b>
5.1. ISOLATED DC/DC CONVERTER STATIC SPECIFICATIONS .....	5
5.2. DIGITAL ISOLATOR ELECTRICAL CHARACTERISTICS .....	7
5.3. TYPICAL PERFORMANCE CHARACTERISTICS .....	11
5.4. PARAMETER MEASUREMENT INFORMATION .....	12
<b>6. HIGH VOLTAGE FEATURE DESCRIPTION</b> .....	<b>12</b>
6.1. INSULATION AND SAFETY RELATED SPECIFICATIONS.....	12
6.2. DIN VDE V 0884-11 (VDE V 0884-11) :2017-01 INSULATION CHARATERISTICS .....	12
6.3. REGULATORY INFORMATION .....	14
<b>7. FUNCTION DESCRIPTION</b> .....	<b>14</b>
7.1. OVERVIEW .....	14
7.2. DEVICE FUNCTIONAL MODES .....	14
7.3. EMI CONSIDERATIONS.....	15
7.4. OUTPUT SHORT AND OVER TEMPERATURE PROTECTION .....	15
<b>8. APPLICATION NOTE</b> .....	<b>15</b>
8.1. TYPICAL APPLICATION .....	15
8.2. PCB LAYOUT .....	16
<b>9. PACKAGE INFORMATION</b> .....	<b>17</b>
<b>10. ORDER INFORMATION</b> .....	<b>18</b>
<b>11. DOCUMENTATION SUPPORT</b> .....	<b>18</b>
<b>12. TAPE AND REEL INFORMATION</b> .....	<b>19</b>
<b>13. REVISION HISTORY</b> .....	<b>20</b>

### 1. Pin Configuration And Functions

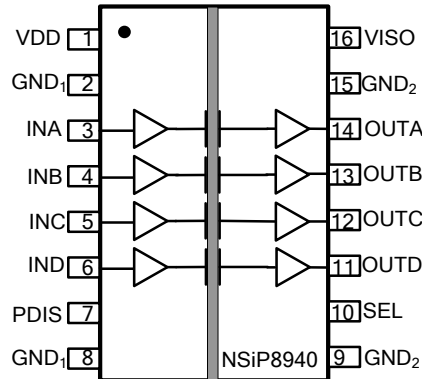

Figure 1.1 NSiP8940 Package

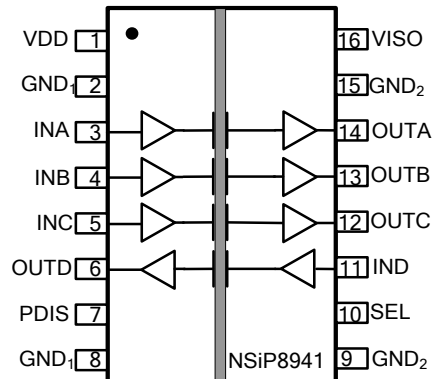

Figure 1.2 NSiP8941 Package

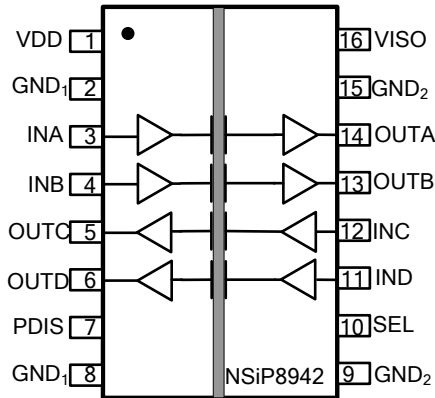

Figure 1.3 NSiP8942 Package

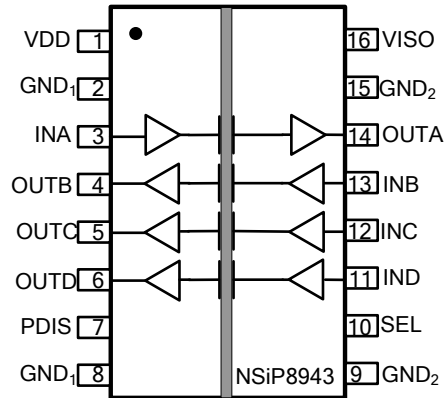

Figure 1.4 NSiP8943 Package

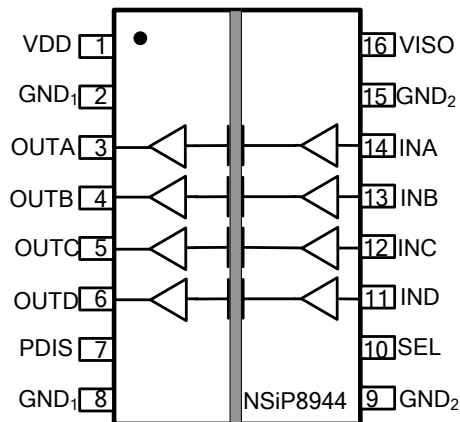

Figure 1.5 NSiP8944 Package

Table1.1 NSiP8940/ NSiP8941/ NSiP8942/ NSiP8943/NSiP8944 Pin Configuration and Description

NSiP8940 PIN NO.	NSiP8941 PIN NO.	NSiP8942 PIN NO.	NSiP8943 PIN NO.	NSiP8944 PIN NO.	SYMBOL	FUNCTION
1	1	1	1	1	VDD	Power Supply for Isolator Side 1
2	2	2	2	2	GND1	Ground 1, the ground reference for Isolator Side 1
3	3	3	3	14	INA	Logic Input A
4	4	4	13	13	INB	Logic Input B
5	5	12	12	12	INC	Logic Input C
6	11	11	11	11	IND	Logic Input D
7	7	7	7	7	PDIS	Power Disable. When tied to any GND1 pin, the VISO output voltage is active. When a logic high voltage is applied, the VISO output voltage is shut down. Internal weak pull-down ,can be floating (for better noise immunity, can connect this pin to GND1)
8	8	8	8	8	GND1	Ground 1, the ground reference for Isolator Side 1
9	9	9	9	9	GND2	Ground 2, the ground reference for Isolator Side 2
10	10	10	10	10	SEL	VISO output voltage select, VISO=5V when SEL short to VISO, VISO=3.3V when SEL short to GND2 or floating.
11	6	6	6	6	OUTD	Logic Output D
12	12	5	5	5	OUTC	Logic Output C
13	13	13	4	4	OUTB	Logic Output B
14	14	14	14	3	OUTA	Logic Output A
15	15	15	15	15	GND2	Ground 2, the ground reference for Isolator Side 2
16	16	16	16	16	VISO	Secondary Supply Voltage Output for External Load.

## 2. Absolute Maximum Ratings

Parameters	Symbol	Min	Typ	Max	Unit	Comments
Power Supply Voltage	VDD	-0.5		6	V	
Maximum Input Voltage	V <sub>INA</sub> , V <sub>INB</sub> V <sub>INC</sub> , V <sub>IND</sub>	-0.4		VCC1 <sup>2</sup> +0.4 <sup>1</sup>	V	

Maximum Output Voltage	V <sub>OUTA</sub> , V <sub>OUTB</sub> V <sub>OUTC</sub> , V <sub>OUTD</sub>	-0.4		VCC2 <sup>2</sup> +0.4 <sup>1</sup>	V	
Output current	I <sub>o</sub>	-15		15	mA	
Maximum Surge Isolation Voltage	V <sub>IOSM</sub>			5.3	kV	
Operating Temperature	T <sub>opr</sub>	-40		125	°C	
Storage Temperature	T <sub>stg</sub>	-40		150	°C	
Electrostatic discharge	HBM			±6000	V	
	CDM			±2000	V	

<sup>1</sup>VCC1 is input side supply, VCC2 is output side supply

### 3. Recommended Operating Conditions

Parameters	Symbol	min	typ	max	unit
Power Supply Voltage	VDD	3		5.5	V
Operating Temperature	T <sub>opr</sub>	-40		125	°C
High Level Input Voltage	V <sub>IH</sub>	0.7*VCC1 <sup>1</sup>		VCC1 <sup>1</sup>	V
Low Level Input Voltage	V <sub>IL</sub>	0		0.3*VCC1 <sup>1</sup>	V
Data rate	DR			150	Mbps

<sup>1</sup>VCC1 is input side supply

### 4. Thermal Characteristics

Parameters	Symbol	SOW16	Unit
IC Junction-to-Air Thermal Resistance	θ <sub>JA</sub>	56.8	°C/W
Junction-to-case (top) thermal resistance	θ <sub>JC (top)</sub>	15.6	°C/W
Junction-to-board thermal resistance	θ <sub>JB</sub>	28.5	°C/W

### 5. Specifications

#### 5.1. Isolated DC/DC Converter Static Specifications

(VDD=4.5V~5.5V, SEL=VISO, Ta=-40°C to 125°C. Unless otherwise noted, Typical values are at VDD = 5V, Ta = 25°C)

Parameters	Symbol	Min	Typ	Max	Unit	Comments
Isolated Supply Voltage	VISO	4.75	5	5.25	V	
Line Regulation	V <sub>ISO(LINE)</sub>			2	mV/V	
Load Regulation	V <sub>ISO(LOAD)</sub>		0.2	0.5	%	
Output Ripple	V <sub>ISO(RIP)</sub>		35		mVpp	
Output Noise	V <sub>ISO(NOISE)</sub>		150		mVpp	

Efficiency at maximum load current	EFF	39	50		%	IISO=100mA,PDIS=0
Output supply current	I <sub>ISO</sub>	100			mA	
VDD supply current without digital isolator	I <sub>VDD_POWER</sub>		2.5	30	uA	PDIS=VDD
			10	20	mA	No VISO Load,PDIS=0
			197	270	mA	IISO=100mA,PDIS=0

(VDD=4.5V~5.5V, SEL=0, Ta=-40°C to 125°C. Unless otherwise noted, Typical values are at VDD = 5V, Ta = 25°C)

Parameters	Symbol	Min	Typ	Max	Unit	Comments
Isolated Supply Voltage	VISO	3.135	3.3	3.465	V	
Line Regulation	V <sub>ISO(LINE)</sub>			2	mV/V	
Load Regulation	V <sub>ISO(LOAD)</sub>		0.2	0.5	%	
Output Ripple	V <sub>ISO(RIP)</sub>		35		mVpp	
Output Noise	V <sub>ISO(NOISE)</sub>		150		mVpp	
Efficiency at maximum load current	EFF	28	41.5		%	IISO=100mA,PDIS=0
Output supply current	I <sub>ISO</sub>	100			mA	
VDD supply current without digital isolator	I <sub>VDD_POWER</sub>		2.5	30	uA	PDIS=VDD
			8	20	mA	No VISO Load,PDIS=0
			157	230	mA	IISO=100mA,PDIS=0

(VDD=3V~3.6V, SEL=0, Ta=-40°C to 125°C. Unless otherwise noted, Typical values are at VDD = 3.3V, Ta = 25°C)

Parameters	Symbol	Min	Typ	Max	Unit	Comments
Isolated Supply Voltage	VISO	3.2	3.3	3.5	V	
Line Regulation	V <sub>ISO(LINE)</sub>			2	mV/V	
Load Regulation	V <sub>ISO(LOAD)</sub>		0.2	2.1	%	
Output Ripple	V <sub>ISO(RIP)</sub>		40		mVpp	
Output Noise	V <sub>ISO(NOISE)</sub>		100		mVpp	
Efficiency at maximum load current	EFF	39	48		%	IISO=60mA,PDIS=0
Output supply current	I <sub>ISO</sub>	60			mA	
VDD supply current without digital isolator	I <sub>VDD_POWER</sub>		2.5	30	uA	PDIS=VDD
			10	20	mA	No VISO Load,PDIS=0
			123	160	mA	IISO=60mA,PDIS=0

5.2. Digital Isolator Electrical Characteristics

Parameters	Symbol	Min	Typ	Max	Unit	Comments
Power on Reset	V <sub>DDPOR</sub>		2.5	3	V	POR threshold as during power-up
	V <sub>DDHYS</sub>		0.2		V	POR threshold Hysteresis
High Level Input Voltage	V <sub>IH</sub>	0.7*VCC1			V	
Low Level Input Voltage	V <sub>IL</sub>			0.3*VCC1	V	
High Level Output Voltage	V <sub>OH</sub>	0.8*VCC2			V	IOH ≥ - 4mA
Low Level Output Voltage	V <sub>OL</sub>			0.2*VCC2	V	IOL ≤ 4mA
Output Impedance	R <sub>out</sub>		50		ohm	
Input Pull high or low Current	I <sub>pull</sub>		8	15	uA	
Common Mode Transient Immunity	CMTI	100	150		kV/us	
Thermal Shutdown Temperature			165		°C	

<sup>1</sup>VCC1 is input side supply,VCC2 is output side supply

(VDD=4.5V~5.5V, SEL=VISO, Ta=-40°C to 125°C,no load. Unless otherwise noted, Typical values are at VDD = 5V, Ta = 25°C)

Parameters	Symbol	Min	Typ	Max	Unit	Comments
Supply current	NSiP8940					
	I <sub>DD(Q0)</sub>		10.3	20	mA	All Input 0V for NSiP8940W0 or All Input at supply for NSiP8940W1
	I <sub>DD(Q1)</sub>		11	30	mA	All Input at supply for NSiP8940W0 or All Input 0V for NSiP8940W1
	I <sub>DD(1M)</sub>		11.6	35	mA	All Input with 1Mbps, C <sub>L</sub> =15pF
	NSiP8941					
	I <sub>DD(Q0)</sub>		10.3	20	mA	All Input 0V for NSiP8941W0 or All Input at supply for NSiP8941W1
	I <sub>DD(Q1)</sub>		12.3	30	mA	All Input at supply for NSiP8941W0 or All Input 0V for NSiP8941W1
	I <sub>DD(1M)</sub>		12.7	35	mA	All Input with 1Mbps, C <sub>L</sub> =15pF
	NSiP8942					
	I <sub>DD(Q0)</sub>		10.3	20	mA	All Input 0V for NSiP8942W0 or All Input at supply for NSiP8942W1
	I <sub>DD(Q1)</sub>		14.3	30	mA	All Input at supply for NSiP8942W0 or All Input 0V for NSiP8942W1
	I <sub>DD(1M)</sub>		20	35	mA	All Input with 1Mbps, C <sub>L</sub> =15pF

	NSiP8943					
	I <sub>DD(Q0)</sub>		10.3	20	mA	All Input 0V for NSiP8943W0 or All Input at supply for NSiP8943W1
	I <sub>DD(Q1)</sub>		16.3	30	mA	All Input at supply for NSiP8943W0 or All Input 0V for NSiP8943W1
	I <sub>DD(1M)</sub>		27.3	50	mA	All Input with 1Mbps, C <sub>L</sub> =15pF
	NSiP8944					
	I <sub>DD(Q0)</sub>		10.3	20	mA	All Input 0V for NSiP8944W0 or All Input at supply for NSiP8944W1
	I <sub>DD(Q1)</sub>		18.3	30	mA	All Input at supply for NSiP8944W0 or All Input 0V for NSiP8944W1
	I <sub>DD(1M)</sub>		35	50	mA	All Input with 1Mbps, C <sub>L</sub> =15pF
Data Rate	DR	0		150	Mbps	
Minimum Pulse Width	PW			5.0	ns	
Propagation Delay	t <sub>PLH</sub>	5	9.0	16	ns	
	t <sub>PHL</sub>	5	9.0	16	ns	
Pulse Width Distortion	PWD			5.0	ns	t <sub>PHL</sub> - t <sub>PLH</sub>
Rising Time	t <sub>r</sub>			5.0	ns	C <sub>L</sub> = 15pF
Falling Time	t <sub>f</sub>			5.0	ns	C <sub>L</sub> = 15pF
Channel-to-Channel Delay Skew	tSK(c2c)			2.5	ns	
Part-to-Part Delay Skew	tSK(p2p)			5.0	ns	

(VDD=4.5V~5.5V, SEL=0, Ta=-40°C to 125°C, no load. . Unless otherwise noted, Typical values are at VDD = 5V, Ta = 25 °C)

Parameters	Symbol	Min	Typ	Max	Unit	Comments
Supply current	NSiP8940					
	I <sub>DD(Q0)</sub>		7.8	20	mA	All Input 0V for NSiP8940W0 or All Input at supply for NSiP8940W1
	I <sub>DD(Q1)</sub>		8	25	mA	All Input at supply for NSiP8940W0 or All Input 0V for NSiP8940W1
	I <sub>DD(1M)</sub>		8.78	20	mA	All Input with 1Mbps, C <sub>L</sub> =15pF
	NSiP8941					
	I <sub>DD(Q0)</sub>		7.8	20	mA	All Input 0V for NSiP8941W0 or All Input at supply for NSiP8941W1

	$I_{DD(Q1)}$		9.8	25	mA	All Input at supply for NSiP8941W0 or All Input 0V for NSiP8941W1
	$I_{DD(1M)}$		11.7	30	mA	All Input with 1Mbps, $C_L=15pF$
NSiP8942						
	$I_{DD(Q0)}$		7.8	20	mA	All Input 0V for NSiP8942W0 or All Input at supply for NSiP8942W1
	$I_{DD(Q1)}$		11.8	25	mA	All Input at supply for NSiP8942W0 or All Input 0V for NSiP8942W1
	$I_{DD(1M)}$		15.3	30	mA	All Input with 1Mbps, $C_L=15pF$
NSiP8943						
	$I_{DD(Q0)}$		7.8	20	mA	All Input 0V for NSiP8943W0 or All Input at supply for NSiP8943W1
	$I_{DD(Q1)}$		13.8	25	mA	All Input at supply for NSiP8943W0 or All Input 0V for NSiP8943W1
	$I_{DD(1M)}$		20.3	40	mA	All Input with 1Mbps, $C_L=15pF$
NSiP8944						
	$I_{DD(Q0)}$		7.8	20	mA	All Input 0V for NSiP8944W0 or All Input at supply for NSiP8944W1
	$I_{DD(Q1)}$		15.8	25	mA	All Input at supply for NSiP8944W0 or All Input 0V for NSiP8944W1
	$I_{DD(1M)}$		25.3	40	mA	All Input with 1Mbps, $C_L=15pF$
Data Rate	DR	0		150	Mbps	
Minimum Pulse Width	PW			5.0	ns	
Propagation Delay	$t_{PLH}$	5	9.0	16	ns	
	$t_{PHL}$	5	9.0	16	ns	
Pulse Width Distortion	PWD			5.0	ns	$ t_{PHL} - t_{PLH} $
Rising Time	$t_r$			5.0	ns	$C_L = 15pF$
Falling Time	$t_f$			5.0	ns	$C_L = 15pF$
Channel-to-Channel Delay Skew	$t_{SK(c2c)}$			2.5	ns	
Part-to-Part Delay Skew	$t_{SK(p2p)}$			5.0	ns	

(VDD=3V~3.6V, SEL=0, Ta=-40°C to 125°C, no load. Unless otherwise noted, Typical values are at VDD = 3.3V, Ta = 25°C)

Parameters	Symbol	Min	Typ	Max	Unit	Comments
Supply current	NSiP8940					

	$I_{DD(Q0)}$		9	20	mA	All Input 0V for NSiP8940W0 or All Input at supply for NSiP8940W1
	$I_{DD(Q1)}$		10	25	mA	All Input at supply for NSiP8940W0 or All Input 0V for NSiP8940W1
	$I_{DD(1M)}$		10	30	mA	All Input with 1Mbps, CL=15pF
<b>NSiP8941</b>						
	$I_{DD(Q0)}$		9	20	mA	All Input 0V for NSiP8941W0 or All Input at supply for NSiP8941W1
	$I_{DD(Q1)}$		11.25	25	mA	All Input at supply for NSiP8941W0 or All Input 0V for NSiP8941W1
	$I_{DD(1M)}$		10.14	30	mA	All Input with 1Mbps, CL=15pF
<b>NSiP8942</b>						
	$I_{DD(Q0)}$		9	20	mA	All Input 0V for NSiP8942W0 or All Input at supply for NSiP8942W1
	$I_{DD(Q1)}$		13.5	25	mA	All Input at supply for NSiP8942W0 or All Input 0V for NSiP8942W1
	$I_{DD(1M)}$		16.5	30	mA	All Input with 1Mbps, CL=15pF
<b>NSiP8943</b>						
	$I_{DD(Q0)}$		9	20	mA	All Input 0V for NSiP8943W0 or All Input at supply for NSiP8943W1
	$I_{DD(Q1)}$		15.75	25	mA	All Input at supply for NSiP8943W0 or All Input 0V for NSiP8943W1
	$I_{DD(1M)}$		21.4	50	mA	All Input with 1Mbps, CL=15pF
<b>NSiP8944</b>						
	$I_{DD(Q0)}$		9	20	mA	All Input 0V for NSiP8944W0 or All Input at supply for NSiP8944W1
	$I_{DD(Q1)}$		18	30	mA	All Input at supply for NSiP8944W0 or All Input 0V for NSiP8944W1
	$I_{DD(1M)}$		26.5	50	mA	All Input with 1Mbps, CL=15pF
Data Rate	DR	0		150	Mbps	
Minimum Pulse Width	PW			5.0	ns	
Propagation Delay	$t_{PLH}$	5	9.0	16	ns	
	$t_{PHL}$	5	9.0	16	ns	
Pulse Width Distortion	PWD			5.0	ns	$ t_{PHL} - t_{PLH} $
Rising Time	$t_r$			5.0	ns	$C_L = 15pF$

Falling Time	$t_f$			5.0	ns	$C_L = 15\text{pF}$
Channel-to-Channel Delay Skew	$t_{SK(c2c)}$			2.5	ns	
Part-to-Part Delay Skew	$t_{SK(p2p)}$			5.0	ns	

### 5.3. Typical Performance Characteristics

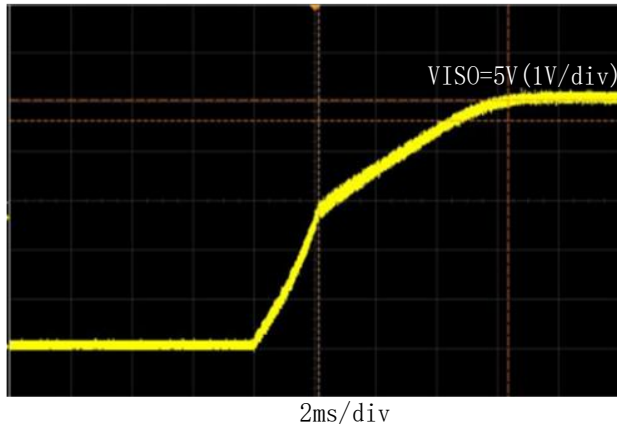

Figure 5.1 5V→5V Soft start at no load

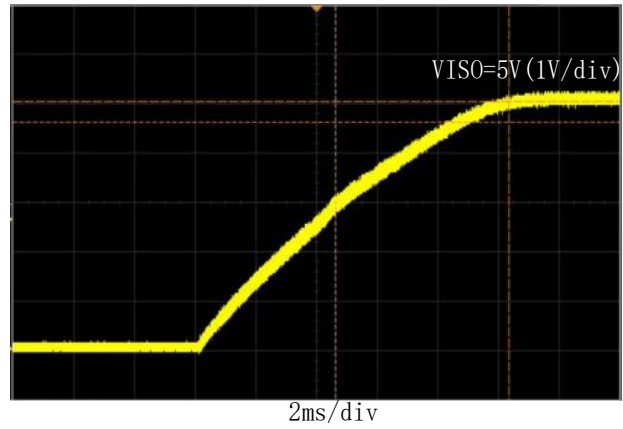

Figure 5.2 5V→5V Soft start at full load

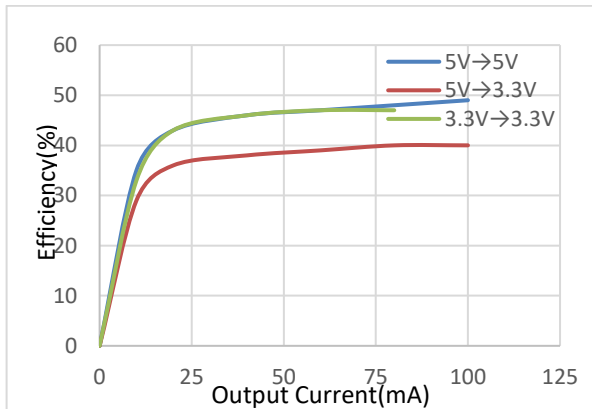

Figure 5.3 Output current vs efficiency

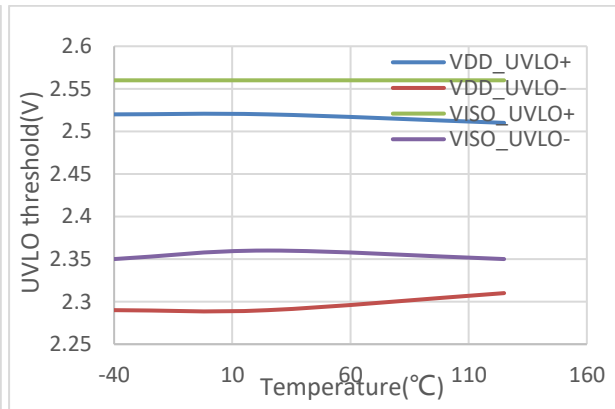

Figure 5.4 Power-Supply Undervoltage Threshold vs Temperature

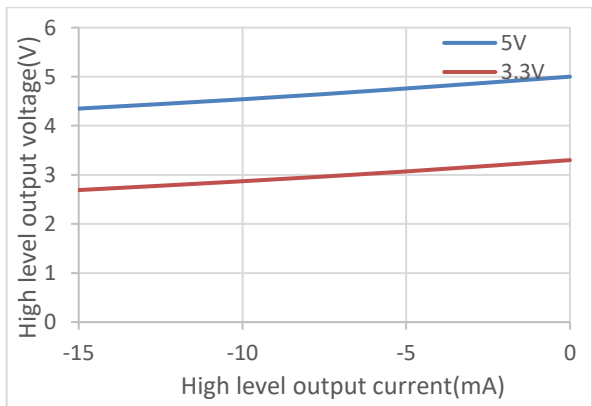

Figure 5.5 High-Level Output Voltage vs Output Current

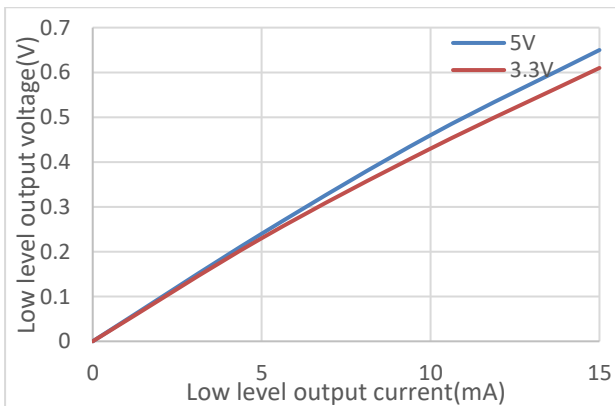

Figure 5.6 Low-Level Output Voltage vs Output Current

5.4. Parameter Measurement Information

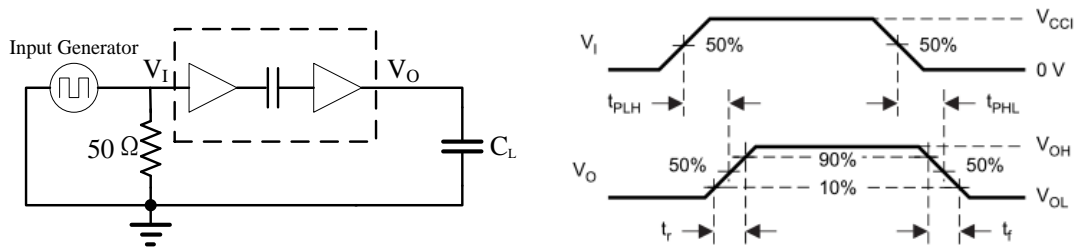

Figure 5.7 Switching Characteristics Test Circuit and Waveform

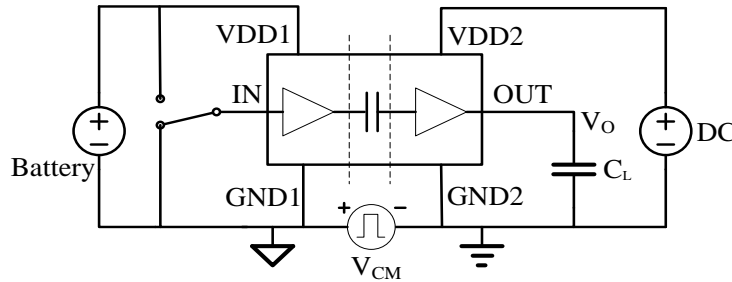

Figure 5.8 Common-Mode Transient Immunity Test Circuit

6. High Voltage Feature Description

6.1. Insulation And Safety Related Specifications

Parameters	Symbol	Value	Unit	Comments
Minimum External Air Gap (Clearance)	L(I01)	8.0	mm	Shortest terminal-to-terminal distance through air
Minimum External Tracking (Creepage)	L(I02)	8.0	mm	Shortest terminal-to-terminal distance across the package surface
Minimum internal gap	DTI	20	um	Distance through insulation
Tracking Resistance(Comparative Tracking Index)	CTI	>400	V	DIN EN 60112 (VDE 0303-11); IEC 60112
Material Group		II		

6.2. DIN VDE V 0884-11 (VDE V 0884-11) :2017-01 INSULATION CHARATERISTICS

Description	Test Condition	Symbol	Value	Unit
Installation Classification per DIN VDE 0110				
For Rated Mains Voltage ≤ 150V <sub>rms</sub>			I to IV	

For Rated Mains Voltage $\leq 300V_{rms}$			I to III	
For Rated Mains Voltage $\leq 400V_{rms}$			I to III	
Climatic Classification			10/105/21	
Pollution Degree per DIN VDE 0110, Table 1			2	
Maximum repetitive isolation voltage		$V_{IORM}$	565	Vpeak
Maximum Working Isolation Voltage	AC voltage	$V_{IOWM}$	400	$V_{RMS}$
	DC voltage		565	$V_{DC}$
Input to Output Test Voltage, Method B1	$V_{IORM} \times 1.5 = V_{pd(m)}$ , 100% production test, $t_{ini} = t_m = 1 \text{ sec}$ , $q_{pd} < 5 \text{ pC}$	$V_{pd(m)}$	847	Vpeak
After Environmental Tests Subgroup 1	$V_{IORM} \times 1.2 = V_{pd(m)}$ , $t_{ini} = 60 \text{ sec}$ , $t_m = 10 \text{ sec}$ , $q_{pd} < 5 \text{ pC}$	$V_{pd(m)}$	678	Vpeak
After Input and /or Safety Test Subgroup 2 and Subgroup 3	$V_{IORM} \times 1.2 = V_{pd(m)}$ , $t_{ini} = 60 \text{ sec}$ , $t_m = 10 \text{ sec}$ , partial discharge $< 5 \text{ pC}$	$V_{pd(m)}$	678	Vpeak
Maximum transient isolation voltage	$t = 60 \text{ sec}$	$V_{IOTM}$	5300	Vpeak
Maximum withstanding isolation voltage	$V_{TEST} = V_{ISO}$ , $t = 60 \text{ s}$ (qualification); $V_{TEST} = 1.2 \times V_{ISO}$ , $t = 1 \text{ s}$ (100%production)	$V_{ISO}$	4500	$V_{RMS}$
Maximum Surge Isolation Voltage	Test method per IEC60065, 1.2/50us waveform, $V_{TEST} = V_{IOSM} \times 1.3$	$V_{IOSM}$	5384	Vpeak
Isolation resistance	$V_{IO} = 500V$ at $T_{amb} = T_s$	$R_{IO}$	$> 10^9$	$\Omega$
	$V_{IO} = 500V$ at $100^\circ C \leq T_{amb} \leq 125^\circ C$		$> 10^{11}$	$\Omega$
Isolation capacitance	$f = 1\text{MHz}$	$C_{IO}$	0.6	pF
Input capacitance		$C_I$	2	pF
Total Power Dissipation at 25°C		$P_s$	2201	mW
Safety input, output, or supply current	$\theta_{JA} = 56.8^\circ C/W$ , $V_I = 5.5 \text{ V}$ , $T_J = 150^\circ C$ , $T_A = 25^\circ C$	$I_s$	400	mA
Case Temperature		$T_s$	150	°C

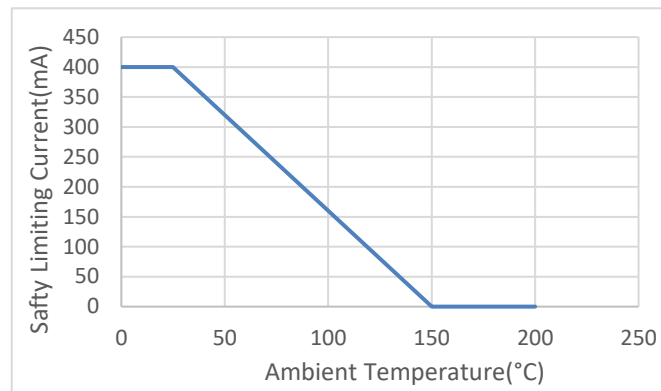

Figure 6.1 NSiP894x Thermal Derating Curve, Dependence of Safety Limiting Values with Case Temperature per DIN VDE V 0884-11

### 6.3. Regulatory Information

The NSiP894x are approved by the organizations listed in table.

	<i>CUL</i>	<i>VDE</i>	<i>CQC</i>
UL 1577 Component Recognition Program <sup>1</sup>	Approved under CSA Component Acceptance Notice 5A	DIN VDE V 0884-11:2017-01 <sup>2</sup>	Certified by CQC11-471543-2012 GB4943.1-2011
Single Protection, 4500V <sub>rms</sub> Isolation voltage	Single Protection, 4500V <sub>rms</sub> Isolation voltage	Basic Insulation 565V <sub>peak</sub> , V <sub>IOSM</sub> =5384V <sub>peak</sub>	Basic insulation at 400V <sub>rms</sub> (565V <sub>peak</sub> )
File (pending)	File (pending)	File (pending)	File (pending)

## 7. Function Description

### 7.1. Overview

The NSiP894x devices are quad-channel digital isolators with integrated isolated DC-DC converter. The digital isolators are based on Novosense capacity isolation barrier technique. The isolated DC-DC converter provides up to 500mW output power using on chip transformer. The feedback PWM signal is sent to primary side by a digital isolator based on capacity isolation technology. The NSiP894x device are safety certified by UL1577 support 4.5kV<sub>rms</sub> insulation withstand voltages, while providing high electromagnetic immunity and low emissions. The data rate of the NSiP894x is up to 150Mbps, and the common-mode transient immunity (CMTI) is up to 150kV/us. The device can go into standby mode when the PDIS pin set to high, and there is no output voltage at VISO pin.

The high integrated solution can help to simplify system design and improve reliability. The NSiP894x devices are suitable for the limited PCB space applications. The devices are also suitable for wide temperature application which the most the power module can not support.

### 7.2. Device Functional Modes

The NSiP894x devices provide 5V to 5V, 5V to 3.3V, 3.3V to 3.3V conversion mode, the output voltage can be set by SEL pin. Supply configuration table showed below.

<i>PDIS PIN</i>	<i>SEL PIN</i>	<i>VDD</i>	<i>VISO</i>
Shorted to GND1	Shorted to VISO	5V	5V

Shorted to GND1	Shorted to GND2	5V	3.3V
Shorted to GND1	Shorted to GND2	3.3V	3.3V
Shorted to VDD1	X	3.3V/5V	0V

**7.3. EMI Considerations**

The NSiP894x devices are using on chip transformer, so the power transfer must operate at high frequency allow higher efficiency transfer using the small transformer. This will cause emissions which need to pay attention to PCB layout if the application allow low emission. Please see the application note if needed.

**7.4. Output Short And Over Temperature Protection**

The NSiP894x devices are protected against output short. When the devices detect the output is short, the device will be in Hiccup mode and the transfer power will be limited. So the temperature of the device will be low, and the device is protected.

The NSiP894x devices are also protected against over temperature. When the devices detect the chip is over 165°C, the device will be shut down until the temperature of the device is below 145°C.

**8. Application Note**

**8.1. Typical Application**

The NSiP894x requires a 0.1 μF and 10uF bypass capacitors between VDD and GND1, VISO and GND2. The capacitor should be placed as close as possible to the package. This is very important for the performance of the device. The figure 8.1 is the basic schematic of NSiP894x and the figure 8.2 is the typical isolated RS485 schematic using NSiP894x.

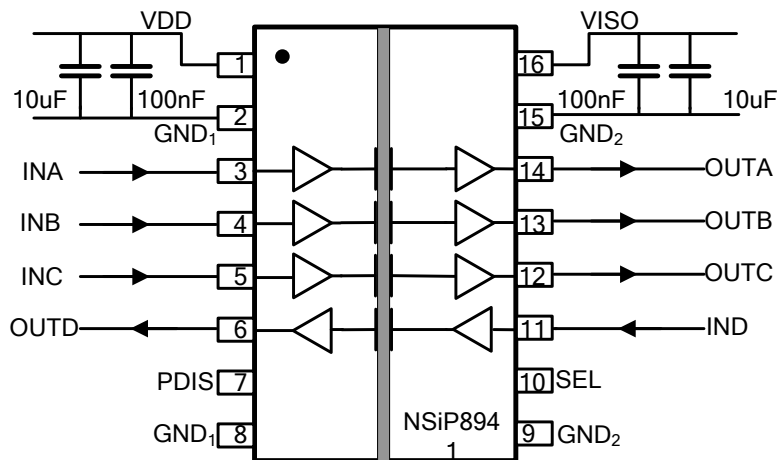

Figure 8.1 Basic schematic of NSiP894x

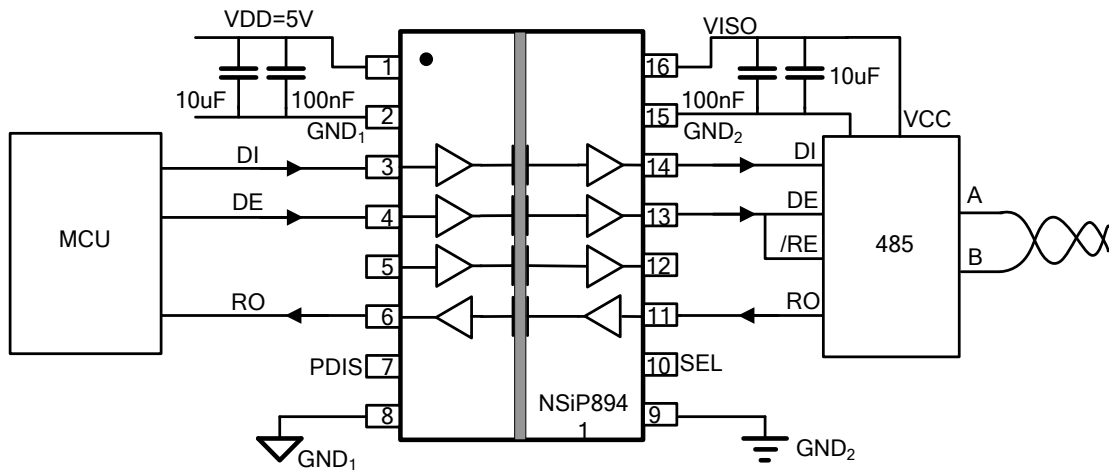

Figure 8.2 Isolated RS485 schematic using NSiP894x

### 8.2. PCB Layout

The recommended PCB layout shown below. The low ESR capacitor C1 should be closed to PIN1 and PIN2, the distance should be less than 10mm. The low ESR capacitor C3 should be closed to PIN15 and PIN16, the distance should be less than 1mm.

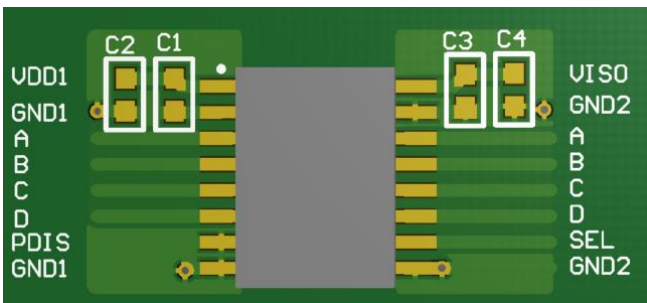

Figure 8.3 Recommended PCB Layout — Top Layer

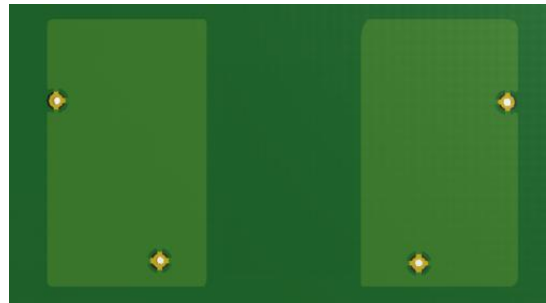

Figure 8.4 Recommended PCB Layout — Bottom Layer

9. Package Information

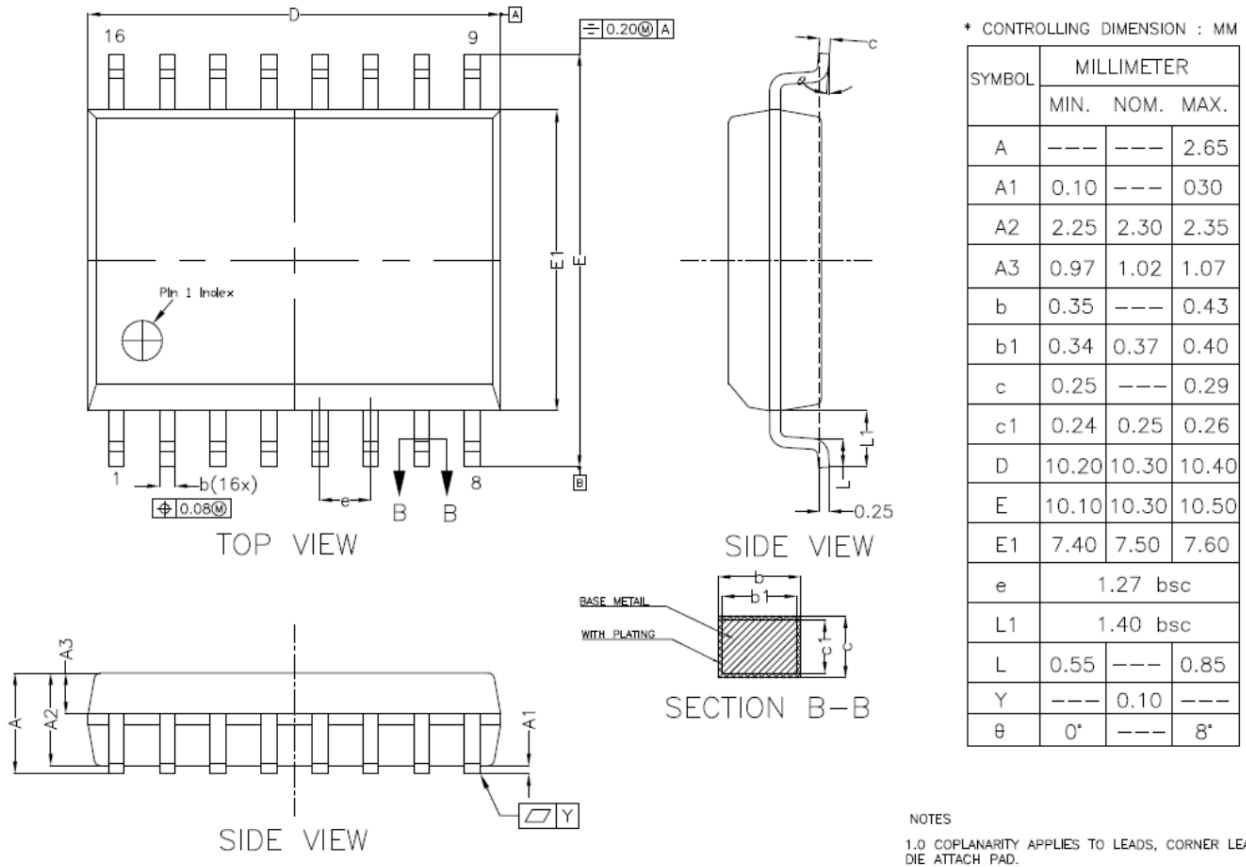
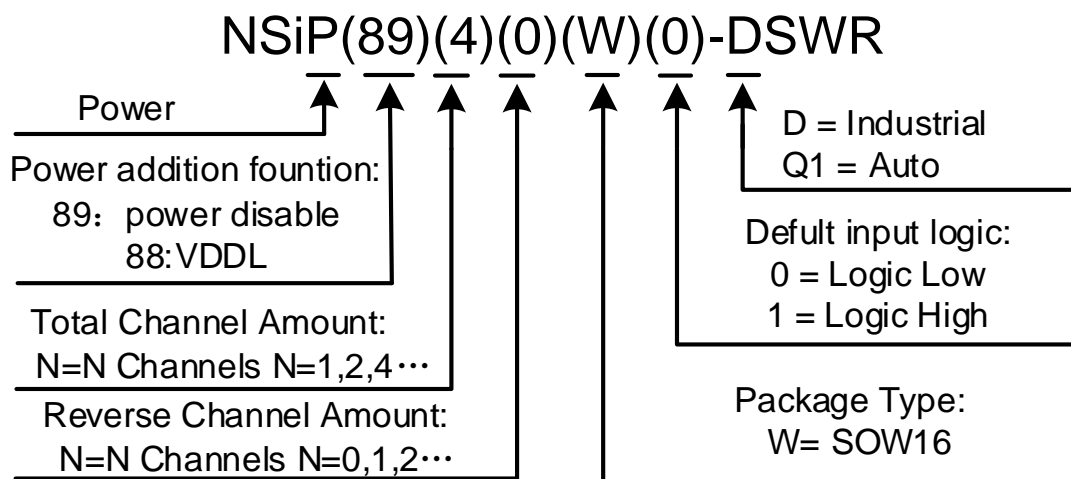

Figure 9.1 SOW16 Package Shape and Dimension in millimeters

### 10. Order Information

Part Number	Isolation Rating (kV)	Number of side 1 inputs	Number of side 2 inputs	Max Data Rate (Mbps)	Default input logic	Temperature	MSL	Package Type	Package Drawing	SPQ
NSIP8940W0-DSWR	4.5	4	0	150	Low	-40 to 125°C	3	SOP16 (300mil)	SOW16	1000
NSIP8940W1-DSWR	4.5	4	0	150	High	-40 to 125°C	3	SOP16 (300mil)	SOW16	1000
NSIP8941W0-DSWR	4.5	3	1	150	Low	-40 to 125°C	3	SOP16 (300mil)	SOW16	1000
NSIP8941W1-DSWR	4.5	3	1	150	High	-40 to 125°C	3	SOP16 (300mil)	SOW16	1000
NSIP8942W0-DSWR	4.5	2	2	150	Low	-40 to 125°C	3	SOP16 (300mil)	SOW16	1000
NSIP8942W1-DSWR	4.5	2	2	150	High	-40 to 125°C	3	SOP16 (300mil)	SOW16	1000
NSIP8943W0-DSWR	4.5	1	3	150	Low	-40 to 125°C	3	SOP16 (300mil)	SOW16	1000
NSIP8943W1-DSWR	4.5	1	3	150	High	-40 to 125°C	3	SOP16 (300mil)	SOW16	1000
NSIP8944W0-DSWR	4.5	0	4	150	Low	-40 to 125°C	3	SOP16 (300mil)	SOW16	1000
NSIP8944W1-DSWR	4.5	0	4	150	High	-40 to 125°C	3	SOP16 (300mil)	SOW16	1000

Part Number Rule:



### 11. Documentation Support

Part Number	Product Folder	Datasheet	Technical Documents	Isolator selection guide
NSiP894x	<a href="#">Click here</a>	<a href="#">Click here</a>	<a href="#">Click here</a>	<a href="#">Click here</a>

### 12. Tape And Reel Information

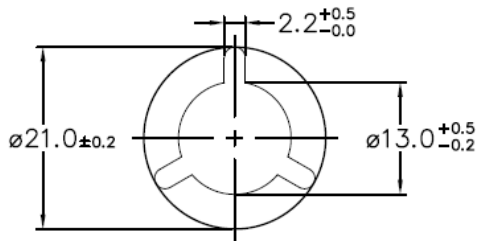
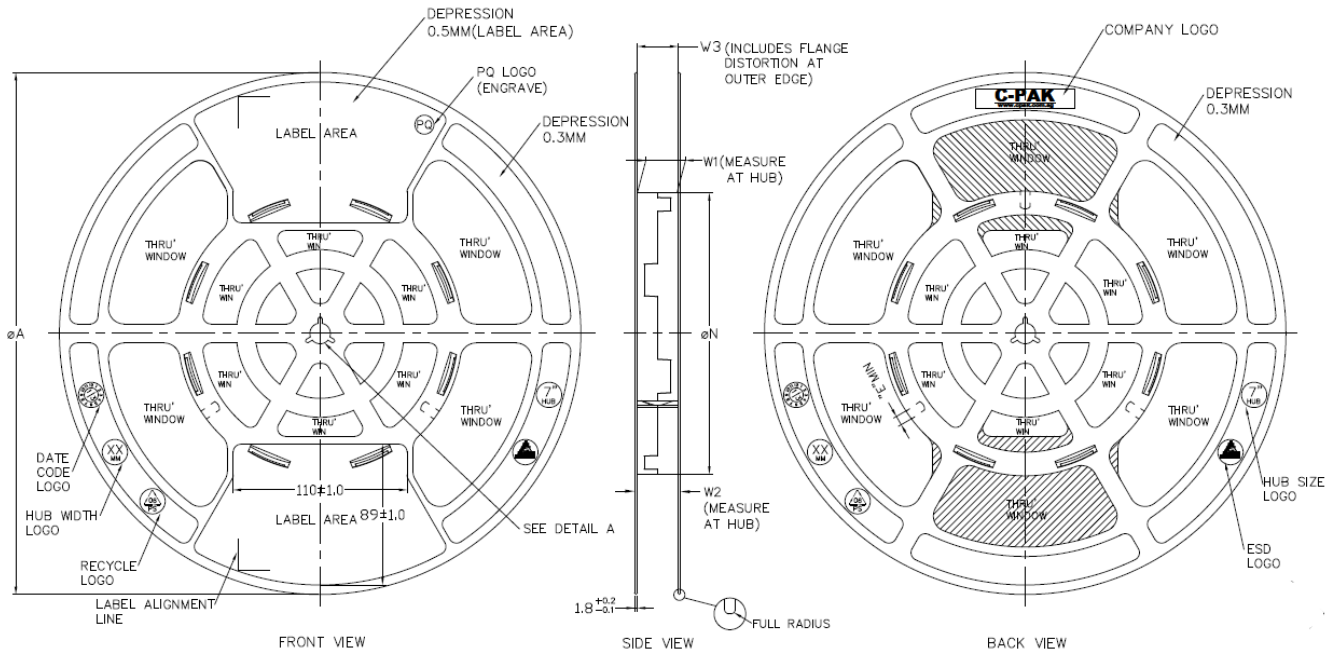

ARBOR HOLE  
DETAIL A  
SCALE : 3:1

PRODUCT SPECIFICATION						
TAPE WIDTH	$\phi A$ $\pm 2.0$	$\phi N$ $\pm 2.0$	W1	W2 (MAX)	W3	E (MIN)
08MM	330	178	8.4 $\pm 0.5$	14.4	SMALL ACCOMMODATE TAPE WIDTH WITHOUT INTERFERENCE	5.5
12MM	330	178	12.4 $\pm 0.5$	18.4		5.5
16MM	330	178	16.4 $\pm 0.5$	22.4		5.5
24MM	330	178	24.4 $\pm 0.5$	30.4		5.5
32MM	330	178	32.4 $\pm 0.5$	38.4		5.5

SURFACE RESISTIVITY			
LEGEND	SR RANGE	TYPE	COLOUR
A	BELOW $10^{12}$	ANTISTATIC	ALL TYPES
B	$10^6$ TO $10^{11}$	STATIC DISSIPATIVE	BLACK ONLY
C	$10^5$ & BELOW $10^5$	CONDUCTIVE (GENERIC)	BLACK ONLY
E	$10^9$ TO $10^{11}$	ANTISTATIC (COATED)	ALL TYPES

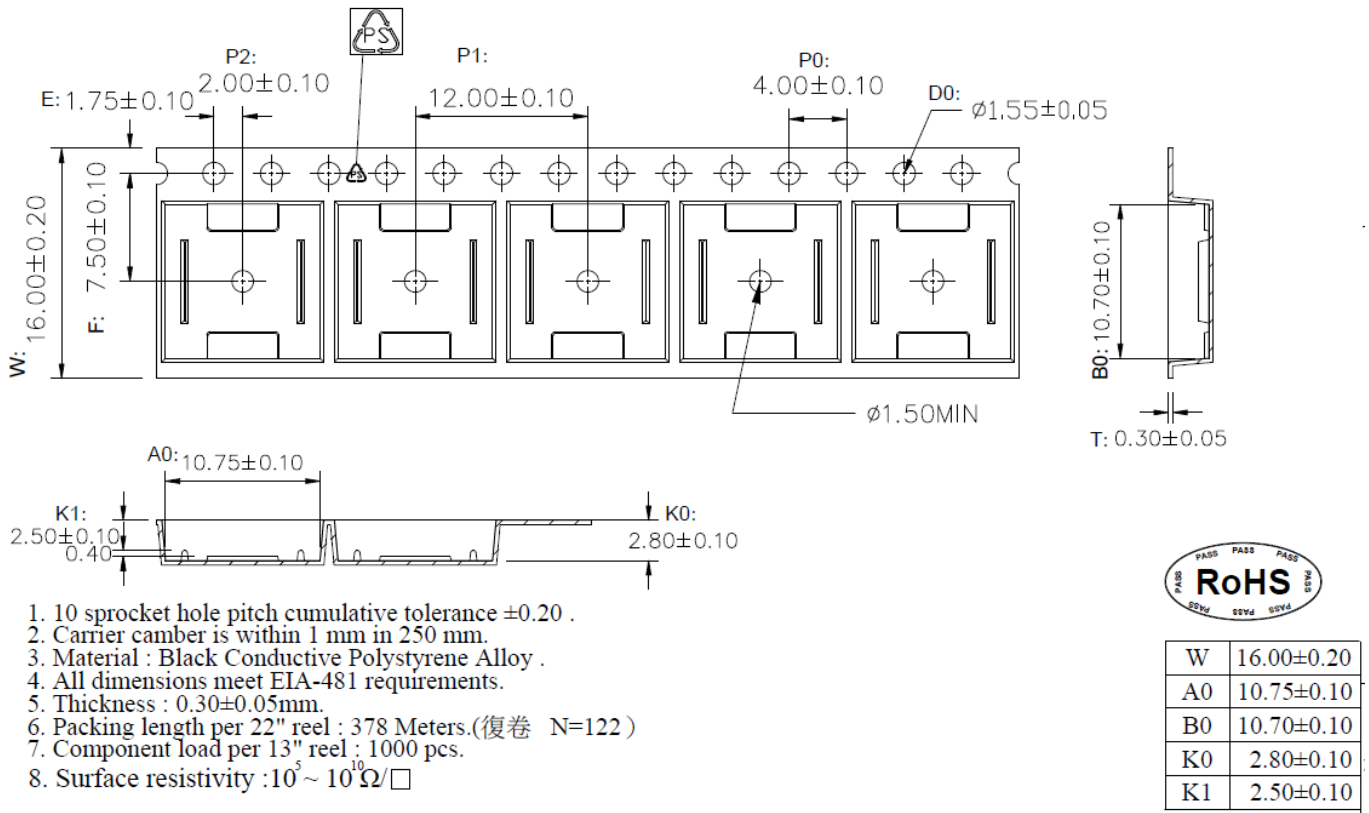

1. 10 sprocket hole pitch cumulative tolerance  $\pm 0.20$ .
2. Carrier camber is within 1 mm in 250 mm.
3. Material : Black Conductive Polystyrene Alloy .
4. All dimensions meet EIA-481 requirements.
5. Thickness :  $0.30 \pm 0.05$ mm.
6. Packing length per 22" reel : 378 Meters.(復巻 N=122)
7. Component load per 13" reel : 1000 pcs.
8. Surface resistivity :  $10^5 \sim 10^{10} \Omega/\square$

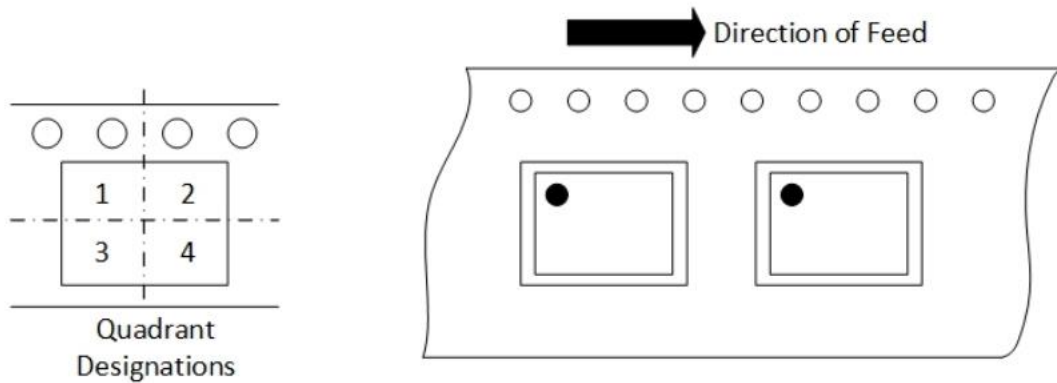

Figure 12.1 Tape and Reel Information of SOW16

### 13. Revision History

Revision	Description	Date
1.0	Initial version	2021/3/28
1.1	Modifying the description of PIN 7	2021/12/1
1.2	Updating relative figures	2022/5/9

## Looking for pricing, stock, or lifecycle information?

Click below to explore more details on WIN SOURCE:

 [View NSIP8941W1-DSWR on WIN SOURCE](#)

 [NOVATEK Information](#)

## Optimize Your Supply Chain with WIN SOURCE Solutions

-  Global Sourcing Solution
-  Obsolete Management
-  Cost Control Management
-  Shortage Management
-  Alternative Solution
-  Excess Inventory Management