

LIN Transceiver

Features

- The MCP2003B is Compliant with Local Interconnect Network (LIN) Bus Specifications 1.3, 2.0, 2.1, 2.2, SAE J2602, and ISO17987
- Supports Baud Rates up to 20 Kbaud with LIN-Compatible Output Driver
- 60V Load Dump Protected
- Very High Electromagnetic Immunity (EMI) Meets Stringent Original Equipment Manufacturers (OEM) Requirements
- Direct Capacitor Coupling Robustness without Transient Voltage Suppressor (TVS):
 - $\pm 35V$ on LBUS (SAE J2962-1)
 - $\pm 85V$ on LBUS (SAE J2962-1)
- High Electrostatic Discharge (ESD) Immunity without TVS:
 - >25 kV on LBUS (SAE J2962-1)
 - >15 kV on VBB (IEC 61000-4-2)
 - >6 kV on LBUS (IEC 61000-4-2)
- Very High Immunity to RF Disturbances Meets Stringent OEM Requirements
- Wide Supply Voltage: 5.5V – 30.0V Continuous
- Extended (E) Temperature Range: $-40^{\circ}C$ to $+125^{\circ}C$
- High (H) Temperature Range: $-40^{\circ}C$ to $+150^{\circ}C$
- Interfaces to PIC[®] MCU EUSART and Standard USARTs
- LIN Bus Pin:
 - Internal pull-up resistor and diode
 - Protected against battery shorts
 - Protected against loss of ground
 - High current drive: >40 mA
- Automatic Thermal Shutdown
- Low-Power Mode:
 - Receiver monitoring bus and transmitter off: ($\cong 5 \mu A$)



Description

This device provides a bidirectional, half-duplex communication, physical interface to automotive and industrial LIN systems to meet the LIN Bus Specification Revision 2.2, SAE J2602, and ISO 17987. The device is both short-circuit and overtemperature protected by internal circuitry. The device has been specifically designed to operate in the automotive operating environment and will survive all specified transient conditions while meeting all of the stringent quiescent current requirements.

Package Types

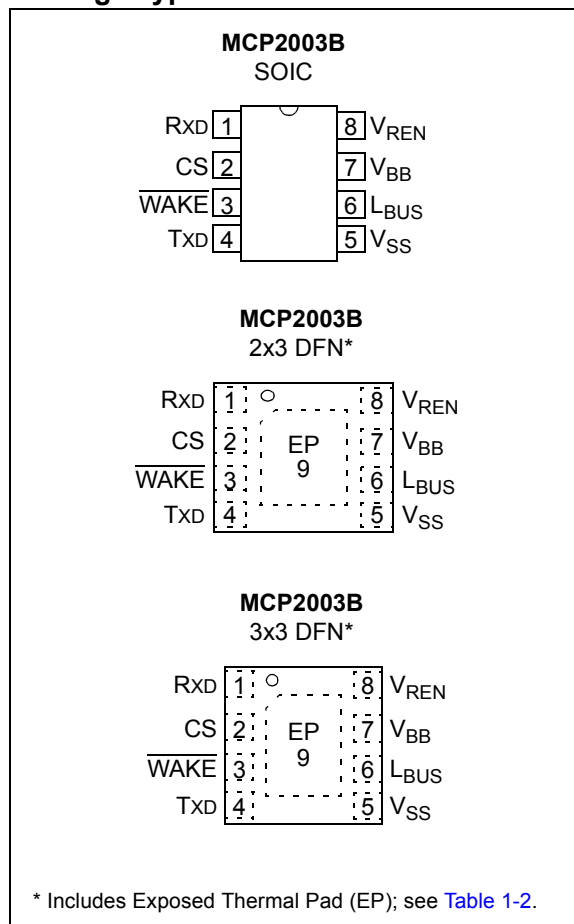

MCP2003B

MCP2003B Block Diagram

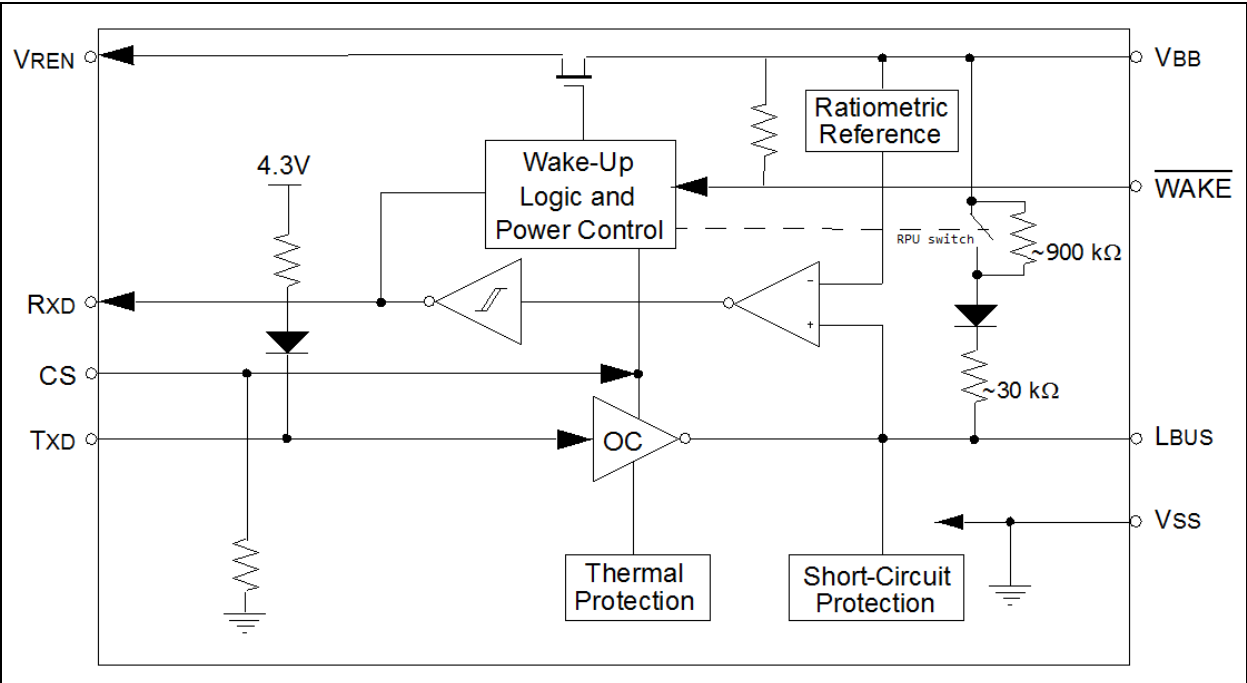

1.0 DEVICE OVERVIEW

The MCP2003B devices provide a physical interface between a microcontroller and a LIN bus. These devices will translate the CMOS/TTL logic levels to LIN logic level, and vice versa. It is intended for automotive and industrial applications with serial bus speeds up to 20 Kbaud.

LIN Bus Specification Revision 2.2 requires that the transceiver of all nodes in the system is connected via the LIN pin, referenced to ground and with a maximum external termination resistance load of 510Ω from LIN bus to battery supply. The 510Ω corresponds to 1 master and 15 slave nodes.

The VREN pin can be used to drive the logic input of an external voltage regulator. This pin is high in all modes except for Power-Down mode.

1.1 External Protection

1.1.1 REVERSE BATTERY PROTECTION

An external reverse-battery-blocking diode should be used to provide polarity protection (see [Example 1-1](#)).

1.1.2 TRANSIENT VOLTAGE PROTECTION (LOAD DUMP)

An external 60V transient suppressor (TVS) diode, between VBB and ground, with a 50Ω transient protection resistor (RTP) in series with the battery supply and the VBB pin serve to protect the device from power transients (see [Example 1-1](#)) and ESD events. While this protection is optional, it is considered good engineering practice.

1.2 Internal Protection

1.2.1 ESD PROTECTION

For component-level ESD ratings, please refer to the maximum operation specifications.

1.2.2 GROUND LOSS PROTECTION

The LIN Bus specification states that the LIN pin must transition to the recessive state when ground is disconnected. Therefore, a loss of ground effectively forces the LIN line to a high-impedance level.

1.2.3 THERMAL PROTECTION

The thermal protection circuit monitors the die temperature and is able to shut down the LIN transmitter.

There are two causes for a thermal overload. A thermal shutdown can be triggered by either, or both, of the following thermal overload conditions.

- LIN bus output overload
- Increase in die temperature due to increase in environment temperature

Driving the TXD and checking the RXD pin makes it possible to determine whether there is a bus contention (Rx = low, Tx = high) or a thermal overload condition (Rx = high, Tx = low). After a thermal overload event, the device will automatically recover once the die temperature has fallen below the recovery temperature threshold (see [Figure 1-1](#)).

FIGURE 1-1: THERMAL SHUTDOWN STATE DIAGRAM

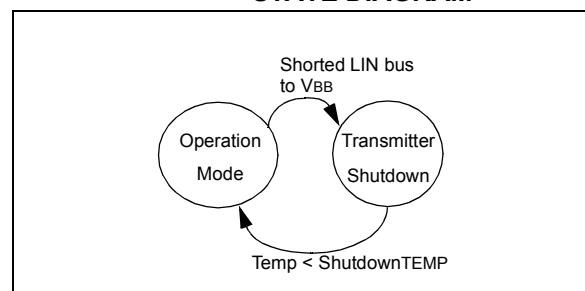

MCP2003B

1.3 Modes of Operation

For an overview of all operational modes, refer to [Table 1-1](#).

1.3.1 POWER-DOWN MODE

In Power-Down mode, everything is off except the wake-up section. The internal 30 k Ω pull-up resistor switch is open, which enables the high ohmic pull-up resistor (900 k Ω typical). This is the lowest power mode. The receiver is off, thus its output is open-drain.

On CS going to a high level or a falling edge on $\overline{\text{WAKE}}$, the device will enter Ready mode as soon as internal voltage stabilizes. Refer to [Section 2.4 “AC Specifications”](#) for further information. In addition, LIN bus activity will change the device from Power-Down mode to Ready mode; The MCP2003B wakes up on a rising edge on L_{BUS} preceded by a low level lasting at least 70 μs typically. See [Figure 1-2](#) about remote wake-up. If CS is held high as the device transitions from Power-Down to Ready mode, the device will transition to either Operation or Transmitter Off mode, depending on TXD input, as soon as internal voltages stabilize.

1.3.2 READY MODE

Transitioning from POR into Ready mode is achieved when $V_{\text{BB}} > V_{\text{BBUV_RISE}}$. Upon entering Ready mode, V_{REN} is enabled and the receiver detect circuit is powered-up. The transmitter remains disabled and the device is ready to receive data but not to transmit.

Upon V_{BB} supply pin power-on, the device will remain in Ready mode as long as CS is low. When CS transitions high, the device will either enter Operation mode if the TXD pin is held high, or the device will enter Transmitter Off mode if the TXD pin is held low.

1.3.3 OPERATION MODE

In this mode, all internal modules are operational. Note that the part cannot transmit if the pull-up resistance is missing on RX pin. See [Section 1.5.1.1 “RxD Monitoring”](#) for details.

The device will go into Power-Down mode on the falling edge of CS and the TXD pin is held high. The device will enter Transmitter Off mode in the event of a Fault condition such as thermal overload, bus contention or TXD timer expiration.

The V_{BB} to L_{BUS} ~30 k Ω pull-up resistor (R_{SLAVE}) is connected only in Operation mode.

1.3.4 TRANSMITTER OFF MODE

Transmitter Off mode is reached whenever the transmitter is disabled due to a Fault condition. Fault conditions include thermal overload, bus contention, RxD monitoring and TXD timer expiration.

The device will go into Power-Down mode on the falling edge of CS, or return to Operation mode if all faults are resolved.

FIGURE 1-2: OPERATIONAL MODES STATE DIAGRAM – MCP2003B

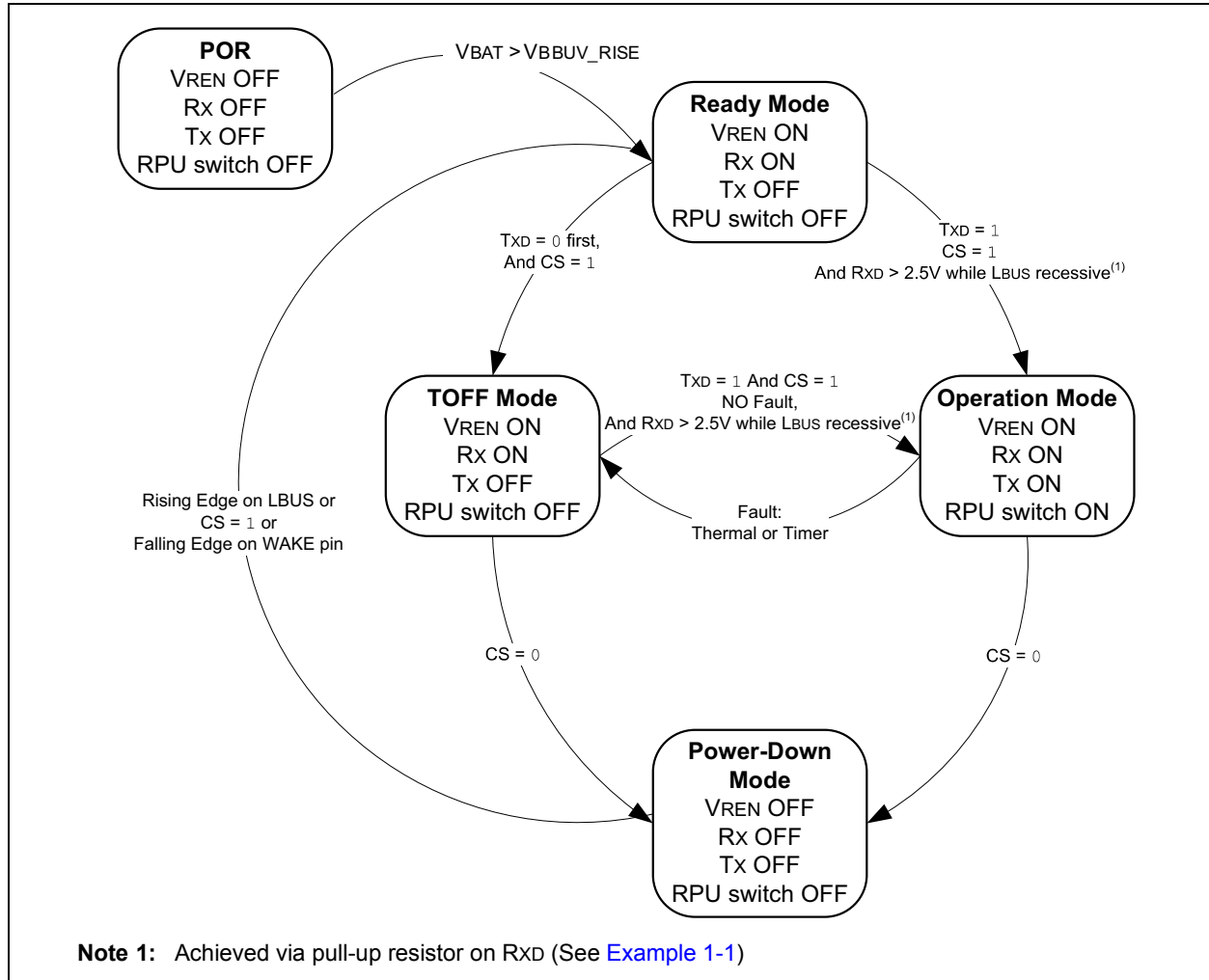

TABLE 1-1: OVERVIEW OF OPERATIONAL MODES

State	Transmitter	Receiver	VREN	Operation	Comments
POR	OFF	OFF	OFF	Check CS: if low, then proceed to Ready mode; If high, transition to either TOFF or Operation mode, depending on TXD.	$V_{BB} > V_{BB(MIN)}$ and Internal Supply stable. High ohmic pull-up resistor enabled (900 kΩ typical).
Ready	OFF	ON	ON	On CS high level, proceed to Operation or TOFF mode.	Bus Off state. High ohmic pull-up resistor enabled (900 kΩ typical).
Operation	ON	ON	ON	On CS low level, proceed to Power-Down. On a fault condition, proceed to TOFF mode.	Normal Operation mode. RxD has to be at a high level (>2.5V typical) while $LBUS$ is recessive.
Power-Down	OFF	Activity Detect	OFF	On CS high level, proceed to Ready mode then proceed to either Operation or TOFF mode. Falling edge on WAKE will put the device into Ready mode. Rising edge on LIN bus will put the device into Ready mode.	Low-Power mode. High ohmic pull-up resistor enabled (900 kΩ typical).
Transmitter Off	OFF	ON	ON	On CS low level, proceed to Power-Down mode; On TxD high and no fault condition, proceed to Operation mode.	High ohmic pull-up resistor enabled (900kΩ typical).

MCP2003B

1.4 Typical Applications

EXAMPLE 1-1: TYPICAL MCP2003B APPLICATION

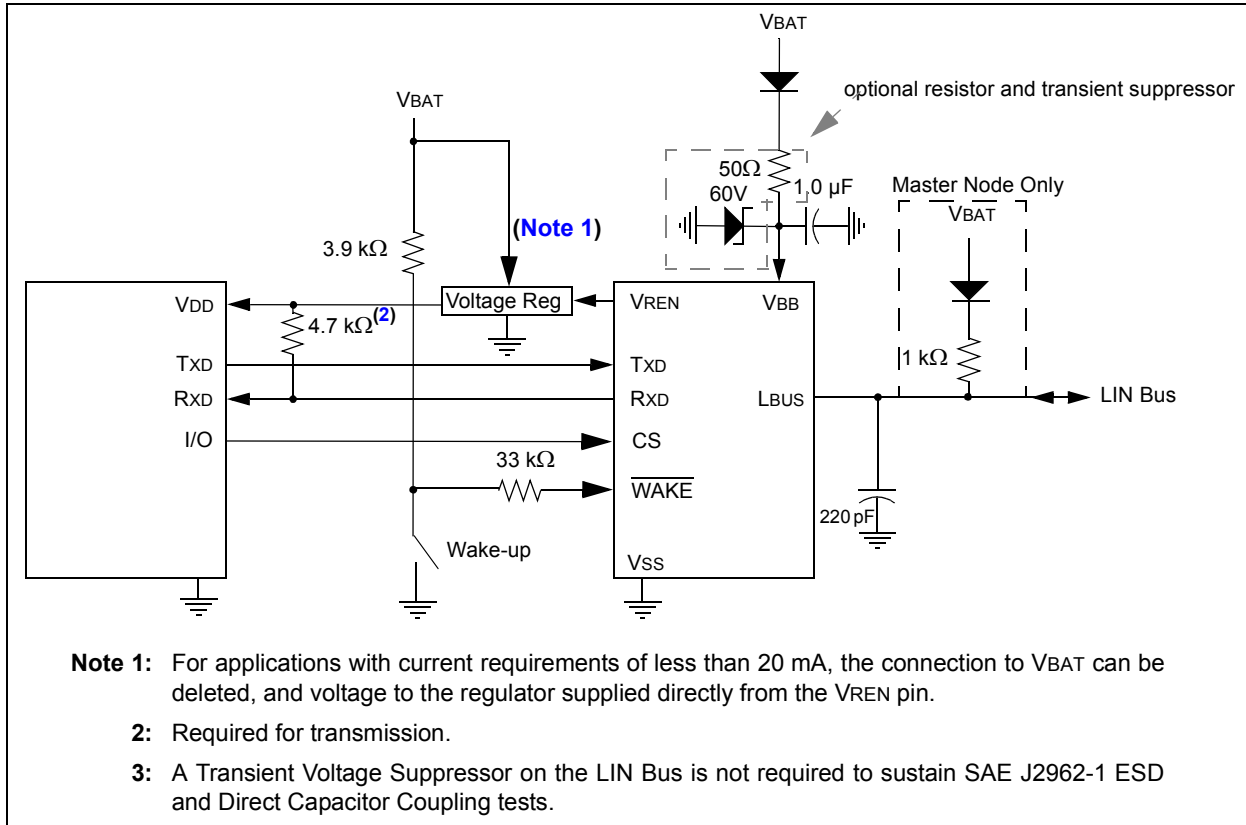

EXAMPLE 1-2: TYPICAL LIN NETWORK CONFIGURATION

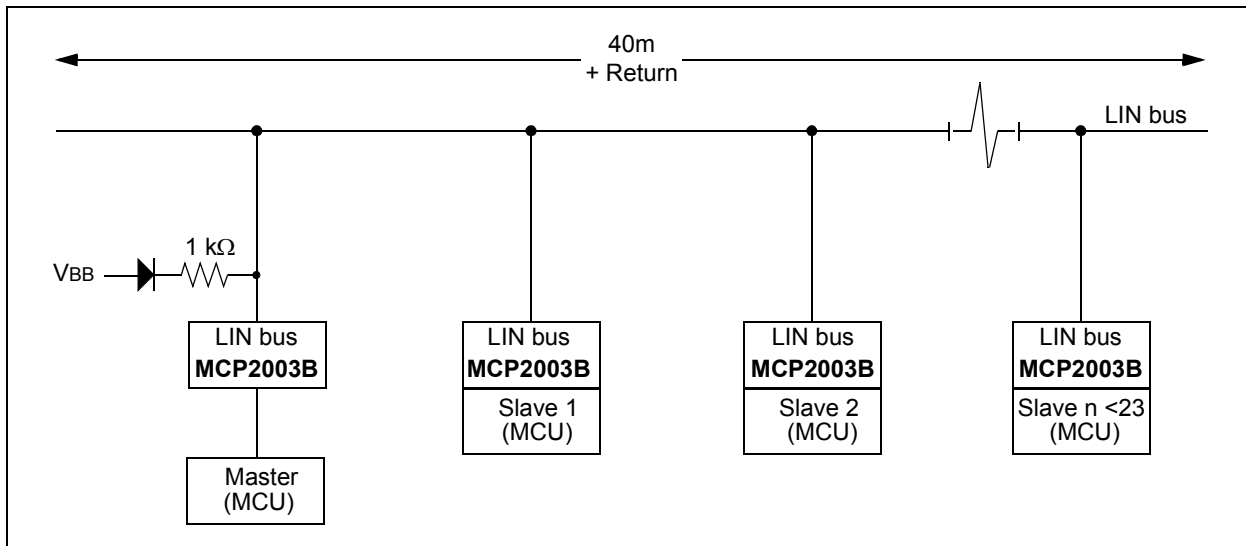

1.5 Pin Descriptions

TABLE 1-2: PINOUT DESCRIPTIONS

Pin Name	8-Lead SOIC	2x3 DFN	3x3 DFN	Normal Operation
RXD	1	1	1	Receive Data Output (OD), HV tolerant
CS	2	2	2	Chip Select (TTL), HV tolerant
$\overline{\text{WAKE}}$	3	3	3	Wake-up, HV tolerant
TXD	4	4	4	Transmit Data Input (TTL), HV tolerant
VSS	5	5	5	Ground
LBUS	6	6	6	LIN Bus (bidirectional)
VBB	7	7	7	Battery Positive
VREN	8	8	8	Voltage Regulator Enable Output
EP	—	9	9	Exposed Thermal Pad. Do not electrically connect or connect to Vss.

Legend: TTL = TTL Input Buffer; OD = Open-Drain Output

1.5.1 RECEIVE DATA OUTPUT (RXD)

The Receive Data Output pin is an open-drain (OD) output and follows the state of the LIN pin, except in Power-Down mode.

1.5.1.1 RXD Monitoring

The RXD pin is internally monitored. It has to be at a high level (> 2.5V typical) while LBUS is recessive in Operation mode. Otherwise, an internal fault will be created and the device will transition to Transmitter Off mode.

Note: A voltage regulator sensing circuit is connected to RXD. This sensing circuit internally monitors the RXD pin when LBUS is recessive (RXD = 1). It will not allow the device to switch (or stay) in Operation Mode if the RXD pin is left open. The RXD pin must be connected to a valid supply through a pull-up resistor as RXD is an open drain pin.

1.5.2 CHIP SELECT (CS)

This is the Chip Select Input pin. An internal pull-down resistor will keep the CS pin low. This is done to ensure that no disruptive data will be present on the bus while the microcontroller is executing a Power-on Reset and an I/O initialization sequence. The pin must detect a high level to activate the transmitter. An internal Low-Pass filter, with a typical time constant of 10 μ s, prevents unwanted wake-up (or transition to Power-Down mode) on glitches.

If CS = 0 when the VBB supply is turned on, the device goes to Ready mode as soon as internal voltages stabilize, and stays there as long as the CS pin is held low (0). In Ready mode, the receiver is on and the LIN transmitter driver is off.

If CS = 1 when the VBB supply is turned on, the device will proceed to Operation mode, or TXOFF (refer to [Figure 1-2](#)), as soon as internal voltages stabilize.

This pin may also be used as a local wake-up input (refer to [Example 1-1](#)). In this implementation, the microcontroller I/O controlling the CS should be converted to a high-impedance input allowing the internal pull-down resistor to keep CS low. An external switch, or other source, can then wake-up both the transceiver and the microcontroller (if powered). Refer to [Section 1.3 “Modes of Operation”](#), for detailed operation of CS.

Note: It is not recommended to tie CS high, as this can result in the device entering Operation mode before the microcontroller is initialized and may result in unintentional LIN traffic. The CS pin is internally pulled down to ground with 190 k Ω when CS is less than V_{IL}, and 2 M Ω when CS is greater than V_{IH}. The current on CS is limited to about 2 μ A when CS is greater than V_{IH}.

1.5.3 WAKE-UP INPUT ($\overline{\text{WAKE}}$)

The $\overline{\text{WAKE}}$ pin has an internal 800 k Ω pull-up to VBB. A falling edge on the $\overline{\text{WAKE}}$ pin causes the device to wake from Power-Down mode. Upon waking, the MCP2003B will enter Ready mode.

1.5.4 TRANSMIT DATA INPUT (TXD)

The Transmit Data Input pin has an internal pull-up. The LIN pin is low (dominant) when TXD is low, and high (recessive) when TXD is high.

For extra bus security, TXD is internally forced to '1' whenever the transmitter is disabled, regardless of external TXD voltage.

MCP2003B

1.5.4.1 TXD Dominant Timeout

If TXD is driven low for longer than approximately 25 ms, the LBUS pin is switched to Recessive mode and the part enters TOFF Mode. This is to prevent the LIN node from permanently driving the LIN Bus dominant. The transmitter is reenabled on TXD rising edge.

1.5.5 GROUND (VSS)

This is the Ground pin.

1.5.6 LIN BUS (LBUS)

The bidirectional LIN Bus pin (LBUS) is controlled by the TXD input. LBUS has a current limited open collector output. To reduce EMI, the edges during the signal changes are slope controlled and include corner rounding control for both falling and rising edges.

The internal LIN receiver observes the activities on the LIN bus, and matches the output signal RXD to follow the state of the LBUS pin.

1.5.6.1 Bus Dominant Timer

The Bus Dominant Timer is an internal timer that deactivates the LBUS transmitter after approximately 25 ms of dominant state on the LBUS pin. The timer is reset on any recessive LBUS state.

The LIN bus transmitter will be reenabled after a recessive state on the LBUS pin as long as CS is high. Disabling can be caused by the LIN bus being externally held dominant, or by TXD being driven low.

1.5.7 BATTERY (VBB)

This is the Battery Positive Supply Voltage pin.

1.5.8 VOLTAGE REGULATOR ENABLE OUTPUT (VREN)

This is the External Voltage Regulator Enable pin. Open-drain output is pulled high to VBB in all modes except Power-Down.

1.5.9 EXPOSED THERMAL PAD (EP)

Do not electrically connect, or connect to VSS.

2.0 ELECTRICAL CHARACTERISTICS

2.1 Absolute Maximum Ratings†

V _{IN} DC Voltage on RXD, TXD, CS	-0.3 to +50V
V _{IN} DC Voltage on $\overline{\text{WAKE}}$ and VREN	-0.3 to +V _{BB}
V _{BB} Battery Voltage, continuous, non-operating ⁽¹⁾	-0.3 to +50V
V _{BB} Battery Voltage, non-operating (LIN bus recessive) ⁽²⁾	-0.3 to +60V
V _{BB} Battery Voltage, transient ISO 7637 Test 1	-200V
V _{BB} Battery Voltage, transient ISO 7637 Test 2a	+150V
V _{BB} Battery Voltage, transient ISO 7637 Test 3a	-300V
V _{BB} Battery Voltage, transient ISO 7637 Test 3b	+200V
V _{LBUS} Bus Voltage, continuous	-18 to +50V
V _{LBUS} Bus Voltage, transient ⁽³⁾	-27 to +60V
V _{LBUS} Bus Voltage, Direct Capacitor Coupling without TVS (SAE J2962-1)	±35V and ±85V
I _{LBUS} Bus Short-Circuit Current Limit	200 mA
ESD protection on LIN, without TVS (SAE J2962-1)	±25 kV
ESD protection on LIN, V _{BB} , $\overline{\text{WAKE}}$ (IEC 61000-4-2) ⁽⁴⁾	±6 kV
ESD protection on LIN, V _{BB} , $\overline{\text{WAKE}}$, CS (Human Body Model) ⁽⁵⁾	±8 kV
ESD protection on all other pins (Human Body Model) ⁽⁵⁾	±4 kV
ESD protection on all pins (Charge Device Model) ⁽⁶⁾	±2 kV
ESD protection on all pins (Machine Model) ⁽⁷⁾	±400V
Maximum Junction Temperature	+150°C
Storage Temperature	-65 to +150°C

† **NOTICE:** Stresses above those listed under “Absolute Maximum Ratings” may cause permanent damage to the device. This is a stress rating only and functional operation of the device, at those or any other conditions above those indicated in the operational listings of this specification, is not implied. Exposure to maximum rating conditions for extended periods may affect device reliability.

Note 1: LIN 2.x compliant specification.

2: SAE J2602 compliant specification.

3: ISO 7637/1 load dump compliant (t < 500 ms).

4: According to IEC 61000-4-2, 330Ω, 150 pF and Transceiver EMC Test Specifications [2] to [4]. For $\overline{\text{WAKE}}$ pin to meet the specification, series resistor must be in place (refer to [Example 1-2](#)).

5: According to AEC-Q100-002/JESD22-A114.

6: According to AEC-Q100-011B.

7: According to AEC-Q100-003/JESD22-A115.

MCP2003B

2.2 Nomenclature Used in This Document

Some terms and names used in this data sheet deviate from those referred to in the LIN specifications. Equivalent values are shown in [Table 2-1](#).

TABLE 2-1: EQUIVALENT VALUES

LIN specifications Name	Term used in the following tables	Definition
VBAT	<i>not used</i>	ECU operating voltage
VSUP	V _{BB}	Supply voltage at device pin
IBUS_LIM	I _{SC}	Current Limit of driver
VBUSREC	V _{IH} (L _{BUS})	Recessive state
VBUSDOM	V _{IL} (L _{BUS})	Dominant state

2.3 DC Specifications

DC Specifications	Electrical Characteristics: Unless otherwise indicated, all limits are specified for V _{BB} = 5.5V to 30.0V Extended (E): TA = -40°C to +125°C High (H): TA = -40°C to +150°C					
	Parameter	Sym.	Min.	Typ.	Max.	Units
Power						
V _{BB} Quiescent Operating Current	IBBQ	—	65	150	μA	Operating Mode, bus recessive
		—	—	160	μA	V _{BB} > 18V
V _{BB} Transmitter-off Current	IBBTO	—	60	120	μA	Transmitter off, bus recessive
		—	—	130	μA	V _{BB} > 18V
V _{BB} Power-Down Current	IBBPD	—	6	15	μA	
		—	—	20	μA	V _{BB} > 18V
		—	14	20	μA	LIN bus shorted to GND V _{LIN} = 0V, V _{BB} < 12V
V _{BB} Current with V _{SS} Floating	IBBNOGND	-1	—	1	mA	V _{BB} = 12V, GND to V _{BB} , V _{LIN} = 0-27V
V _{BB} Undervoltage Threshold (switching from Operation mode to TOFF and V _{REN} OFF)	V _{BBUV_FALL}	3.8	4	4.4	V	V _{BB} falling (Note 3)
V _{BB} Undervoltage Recovery Threshold (switching from POR to Ready mode)	V _{BBUV_RISE}	5.5	5.6	6.0	V	V _{BB} rising (Note 3)
Microcontroller Interface						
High-Level Input Voltage (TxD)	V _{IH}	2.0	—	30	V	
Low-Level Input Voltage (TxD)	V _{IL}	-0.3	—	0.8	V	
High-Level Input Current (TxD)	I _{IH}	-5	—	—	μA	Input voltage = 4.0V

Note 1: Internal current limited. 2.0 ms maximum recovery time (R_{L_{BUS}} = 0Ω, T_x = 0.4 V_{REG}, V_{L_{BUS}} = V_{BB}).

2: Node has to sustain the current that can flow under this condition; bus must be operational under this condition.

3: Characterized; not 100% tested.

2.3 DC Specifications (Continued)

DC Specifications	Electrical Characteristics: Unless otherwise indicated, all limits are specified for $V_{BB} = 5.5V$ to $30.0V$ Extended (E): $T_A = -40^{\circ}C$ to $+125^{\circ}C$ High (H): $T_A = -40^{\circ}C$ to $+150^{\circ}C$						
	Parameter	Sym.	Min.	Typ.	Max.	Units	Conditions
Low-Level Input Current (TXD)	I _{IL}	-12	—	—	—	μA	Input voltage = 0.5V
High-Level Voltage (VREN)	V _{HVREN}	-0.3	—	—	$V_{BB} + 0.3$	V	
High-Level Output Current (VREN)	I _{HVREN}	-40	—	—	-5	mA	Output voltage = $V_{BB} - 0.5V$
		-120	—	—	-20		Output voltage = $V_{BB} - 2.0V$
High-Level Input Voltage (CS)	V _{IH}	2.0	—	—	30	V	Through a current limiting resistor
Low-Level Input Voltage (CS)	V _{IL}	-0.3	—	—	0.8	V	
High-Level Input Current (CS)	I _{IH}	—	—	—	10.0	μA	Input voltage = 4.0V
Low-Level Input Current (CS)	I _{IL}	—	—	—	7.0	μA	Input voltage = 0.5V
Low-Level Input Voltage (WAKE)	V _{IL}	$V_{BB} - 4.0V$	—	—	—	V	
High-Level Input Current (WAKE)	I _{IH}	-12	—	—	—	μA	
		-15	—	—	—	μA	$V_{BB} > 18V$
Low-Level Input Current (WAKE)	I _{IL}	-30	—	—	—	μA	
		-45	—	—	—	μA	$V_{BB} > 18V$
Low-Level Output Voltage (RXD)	V _{OL}	—	—	—	0.4	V	I _{IN} = 2 mA
Input Threshold Level (RXD)	V _{TH(RXD)}	—	2.5	—	—	V	RXD > V _{TH} ; LBUS recessive in Operating mode
High-Level Output Current (RXD)	I _{OH}	-1	—	—	-1	μA	V _{LIN} = V_{BB} , V _{RXD} = 5.5V
Bus Interface							
High-Level Input Voltage	V _{IH(LBUS)}	$0.6 V_{BB}$	—	—	—	V	Recessive state
Low-Level Input Voltage	V _{IL(LBUS)}	-8	—	—	$0.4 V_{BB}$	V	Dominant state
Input Hysteresis	V _{HYS}	—	—	—	$0.175 V_{BB}$	V	V _{IH(LBUS)} - V _{IL(LBUS)}
Low-Level Output Current	I _{OL(LBUS)}	40	—	—	200	mA	Output voltage = $0.2 V_{BB}$, $V_{BB} = 12V$
		16.5	—	—	—		Output voltage = $0.2 V_{BB}$, $V_{BB} = 18V$
High-Level Output Current	I _{OH(LBUS)}	—	—	—	20	μA	
Short-Circuit Current Limit	I _{SC}	50	—	—	200	mA	(Note 1)
High-Level Output Voltage	V _{OH(LBUS)}	$0.8 V_{BB}$	—	—	V_{BB}	V	
Driver Dominant Voltage	V _{LOSUP}	—	—	—	1.2	V	R _{LOAD} = 500Ω
Input Leakage Current (at the receiver during dominant bus level)	I _{BUS_PAS_DO M}	-1	-0.4	—	—	mA	Driver off, V _{BUS} = 0V, $V_{BB} = 12V$

Note 1: Internal current limited. 2.0 ms maximum recovery time (R_{LBUS} = 0Ω, T_X = 0.4 V_{REG}, V_{LBUS} = V_{BB}).

2: Node has to sustain the current that can flow under this condition; bus must be operational under this condition.

3: Characterized; not 100% tested.

MCP2003B

2.3 DC Specifications (Continued)

DC Specifications	Electrical Characteristics: Unless otherwise indicated, all limits are specified for $V_{BB} = 5.5V$ to $30.0V$ Extended (E): $T_A = -40^{\circ}C$ to $+125^{\circ}C$ High (H): $T_A = -40^{\circ}C$ to $+150^{\circ}C$					
	Parameter	Sym.	Min.	Typ.	Max.	Units
Input Leakage Current (at the receiver during recessive bus level)	IBUS_PAS_REC	—	12	20	μA	Driver off, $8V < V_{BB} < 18V$, $8V < V_{BUS} < 18V$, $V_{BUS} \geq V_{BB}$
Leakage Current (disconnected from ground)	IBUS_NO_GND	-10	1.0	+10	μA	$GND_{DEVICE} = V_{BB}$, $0V < V_{BUS} < 18V$, $V_{BB} = 12V$
Leakage Current (disconnected from V_{BB})	IBUS_NO_VBB	—	—	10	μA	$V_{BB} = GND$, $0 < V_{BUS} < 18V$, (Note 2)
Receiver Center Voltage	VBUS_CNT	$0.475 V_{BB}$	$0.5 V_{BB}$	$0.525 V_{BB}$	V	$V_{BUS_CNT} = (V_{IL} (L_{BUS}) + V_{IH} (L_{BUS}))/2$
Slave Termination	RSLAVE	20	30	60	$k\Omega$	
Capacitance of Slave Node	CSLAVE	—	—	100	pF	(Note 3)

- Note 1:** Internal current limited. 2.0 ms maximum recovery time ($R_{L_{BUS}} = 0\Omega$, $T_X = 0.4 V_{REG}$, $V_{L_{BUS}} = V_{BB}$).
- 2:** Node has to sustain the current that can flow under this condition; bus must be operational under this condition.
- 3:** Characterized; not 100% tested.

2.4 AC Specifications

AC Characteristics		Electrical Characteristics: Unless otherwise indicated, all limits are specified for V _{BB} = 5.5V to 27.0V Extended (E): T _A = -40°C to +125°C High (H): T _A = -40°C to +150°C				
Parameter	Sym.	Min.	Typ.	Max.	Units	Test Conditions
Bus Interface – Constant Slope Time Parameters						
Slope Rising and Falling Edges	t _{SLOPE}	3.5	—	22.5	μs	7.3V ≤ V _{BB} ≤ 18V
Propagation Delay of Transmitter	t _{TRANSPD}	—	—	4.0	μs	t _{TRANSPD} = max (t _{TRANSPDR} or t _{TRANSPDF})
Propagation Delay of Receiver	t _{RECPD}	—	—	6.0	μs	t _{RECPD} = max (t _{RECPDR} or t _{RECPDF})
Symmetry of Propagation Delay of Receiver Rising Edge w.r.t. Falling Edge	t _{RECSYM}	-2.0	—	2.0	μs	t _{RECSYM} = max (t _{RECPDF} - t _{RECPDR}) R _{RXD} 2.4Ω to V _{CC} , C _{RXD} 20 pF
Symmetry of Propagation Delay of Transmitter Rising Edge w.r.t. Falling Edge	t _{TRANSSYM}	-2.0	—	2.0	μs	t _{TRANSSYM} = max (t _{TRANSPDF} - t _{TRANSPDR})
Duty Cycle 1 @20.0 kbit/sec		0.396	—	—	—	CBUS; RBUS conditions: 1 nF; 1 kΩ 6.8 nF; 660Ω 10 nF; 500Ω T _{HREC} (MAX) = 0.744 × V _{BB} , T _{HDOM} (MAX) = 0.581 × V _{BB} , V _{BB} = 7.0V - 18V; t _{BIT} = 50 μs D1 = t _{BUS_REC} (MIN)/2 × t _{BIT})
Duty Cycle 2 @20.0 kbit/sec		—	—	0.581	—	CBUS; RBUS conditions: 1 nF; 1 kΩ 6.8 nF; 660Ω 10 nF; 500Ω T _{HREC} (MAX) = 0.284 × V _{BB} , T _{HDOM} (MAX) = 0.422 × V _{BB} , V _{BB} = 7.6V - 18V; t _{BIT} = 50 μs D2 = t _{BUS_REC} (MAX)/2 × t _{BIT})
Duty Cycle 3 @10.4 kbit/sec		0.417	—	—	—	CBUS; RBUS conditions: 1 nF; 1 kΩ 6.8 nF; 660Ω 10 nF; 500Ω T _{HREC} (MAX) = 0.778 × V _{BB} , T _{HDOM} (MAX) = 0.616 × V _{BB} , V _{BB} = 7.0V - 18V; t _{BIT} = 96 μs D3 = t _{BUS_REC} (MIN)/2 × t _{BIT})
Duty Cycle 4 @10.4 kbit/sec		—	—	0.590	—	CBUS; RBUS conditions: 1 nF; 1 kΩ 6.8 nF; 660Ω 10 nF; 500Ω T _{HREC} (max) = 0.251 × V _{BB} , T _{HDOM} (MAX) = 0.389 × V _{BB} , V _{BB} = 7.6V - 18V; t _{BIT} = 96 μs D4 = t _{BUS_REC} (MAX)/2 × t _{BIT})
Wake-up Timing						
Bus Activity Debounce time	t _{BDB}	30	70	125	μs	
Bus Activity to V _{REN} on	t _{BACTIVE}	10	60	110	μs	
WAKE to V _{REN} on	t _{WAKE}	—	—	150	μs	
Chip Select to V _{REN} on	t _{CSOR}	—	—	150	μs	V _{REN} floating
Chip Select to V _{REN} off	t _{CSPD}	—	—	200	μs	V _{REN} floating

MCP2003B

2.5 Thermal Specifications

Parameter	Symbol	Typ.	Max.	Units	Test Conditions
Recovery Temperature	$\theta_{RECOVERY}$	+160	—	°C	
Shutdown Temperature	$\theta_{SHUTDOWN}$	+180	—	°C	
Short-Circuit Recovery Time	t_{THERM}	1.5	5.0	ms	
Thermal Package Resistances					
Thermal Resistance, 2x3 8L-DFN	θ_{JA}	75	—	°C/W	
Thermal Resistance, 3x3 8L-DFN	θ_{JA}	56.7	—	°C/W	
Thermal Resistance, 8L-SOIC	θ_{JA}	149.5	—	°C/W	

Note 1: The maximum power dissipation is a function of T_{JMAX} , θ_{JA} and ambient temperature T_A . The maximum allowable power dissipation at an ambient temperature is $P_D = (T_{JMAX} - T_A) \theta_{JA}$. If this dissipation is exceeded, the die temperature will rise above 150°C and the device will go into thermal shutdown.

2.6 Typical Performance Curves

Note: The graphs and tables provided following this note are a statistical summary based on a limited number of samples and are provided for informational purposes only. The performance characteristics listed herein are not tested or guaranteed. In some graphs or tables, the data presented may be outside the specified operating range (e.g., outside specified power supply range) and therefore outside the warranted range.

Note: Unless otherwise indicated, $V_{BB} = 5.5V$ to $18.0V$, Extended (E): $TA = -40^{\circ}C$ to $+125^{\circ}C$ and High (H): $TA = -40^{\circ}C$ to $+150^{\circ}C$.

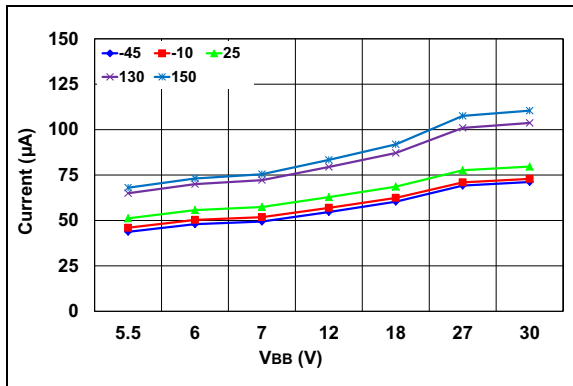

FIGURE 2-1: Typical IBBQ.

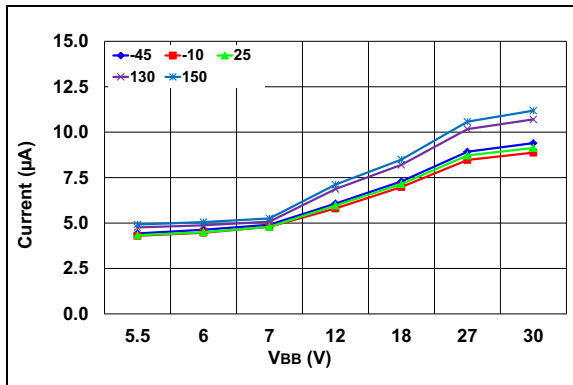

FIGURE 2-2: Typical IBBPD.

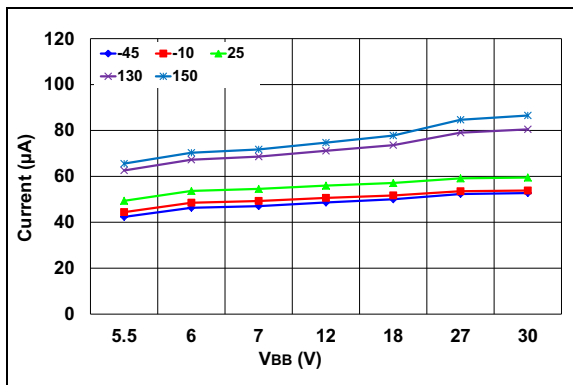

FIGURE 2-3: Typical IBBTO.

MCP2003B

2.7 Timing Diagrams and Specifications

FIGURE 2-4: BUS TIMING DIAGRAM

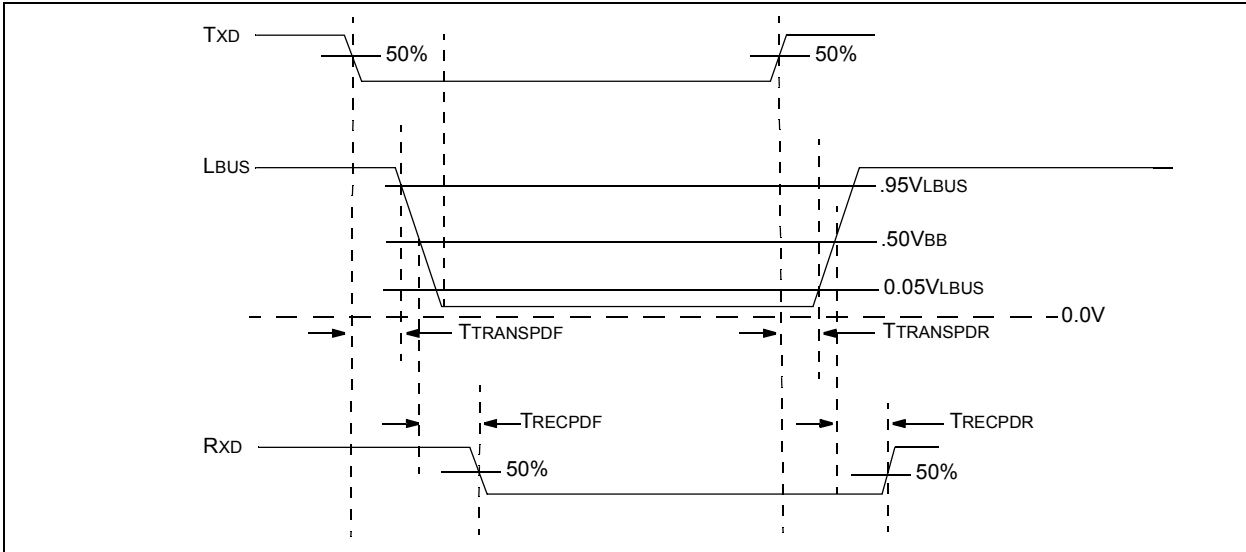

FIGURE 2-5: CS TO VREN TIMING DIAGRAM

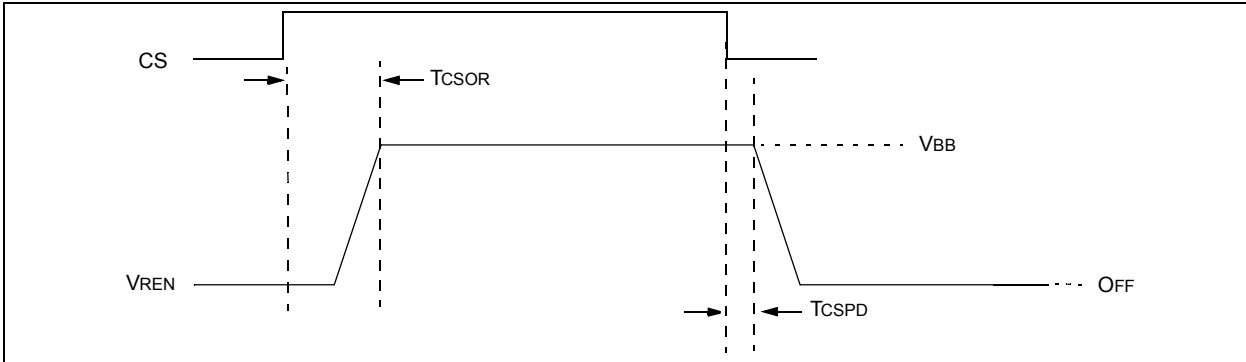
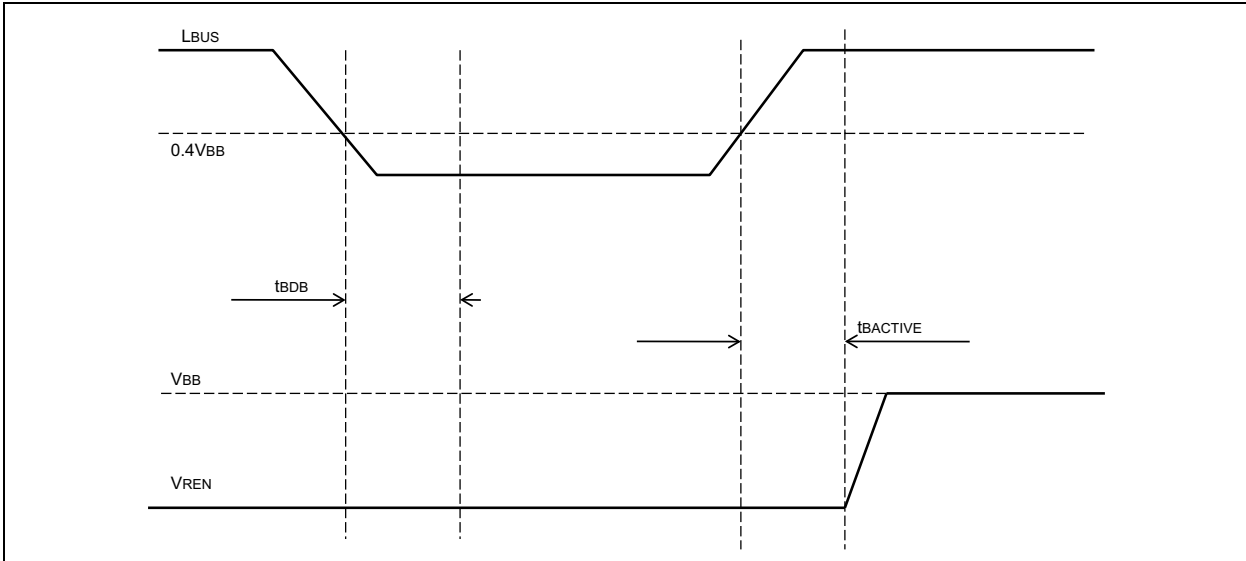

FIGURE 2-6: REMOTE WAKE-UP



3.0 PACKAGING INFORMATION

3.1 Package Marking Information

8-Lead DFN (2x3)



Device	Code
MCP2003B-E/MC	ADP
MCP2003BT-E/MC	ADP
MCP2003B-H/MC	ADR
MCP2003BT-H/MC	ADR

Examples:

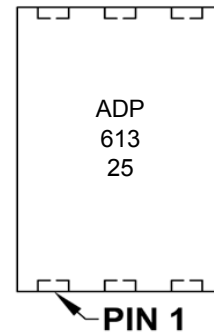

8-Lead DFN (3x3)

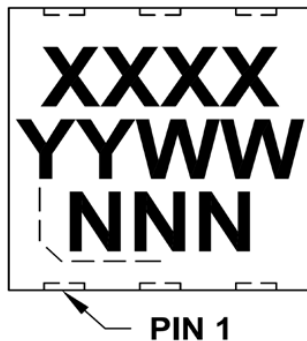

Device	Code
MCP2003B-E/MF	DAEC
MCP2003BT-E/MF	DAEC
MCP2003B-H/MF	DAEE
MCP2003BT-H/MF	DAEE

Examples:

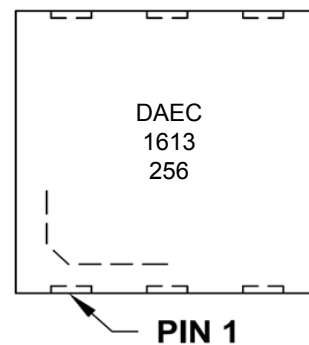

8-Lead SOIC (150 mil)

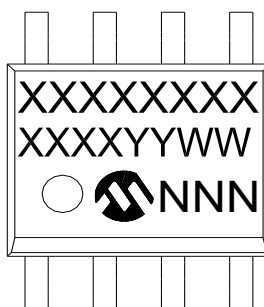

Examples:

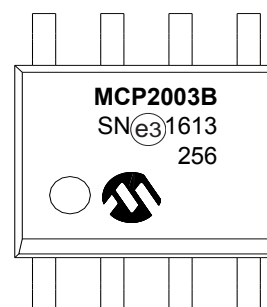

Legend:	XX...X	Customer-specific information
	Y	Year code (last digit of calendar year)
	YY	Year code (last 2 digits of calendar year)
	WW	Week code (week of January 1 is week '01')
	NNN	Alphanumeric traceability code
	(e3)	Pb-free JEDEC® designator for Matte Tin (Sn)
	*	This package is Pb-free. The Pb-free JEDEC designator (e3) can be found on the outer packaging for this package.

Note: In the event the full Microchip part number cannot be marked on one line, it will be carried over to the next line, thus limiting the number of available characters for customer-specific information.

MCP2003B

8-Lead Plastic Dual Flat, No Lead Package (MC) – 2x3x0.9 mm Body [DFN]

Note: For the most current package drawings, please see the Microchip Packaging Specification located at <http://www.microchip.com/packaging>

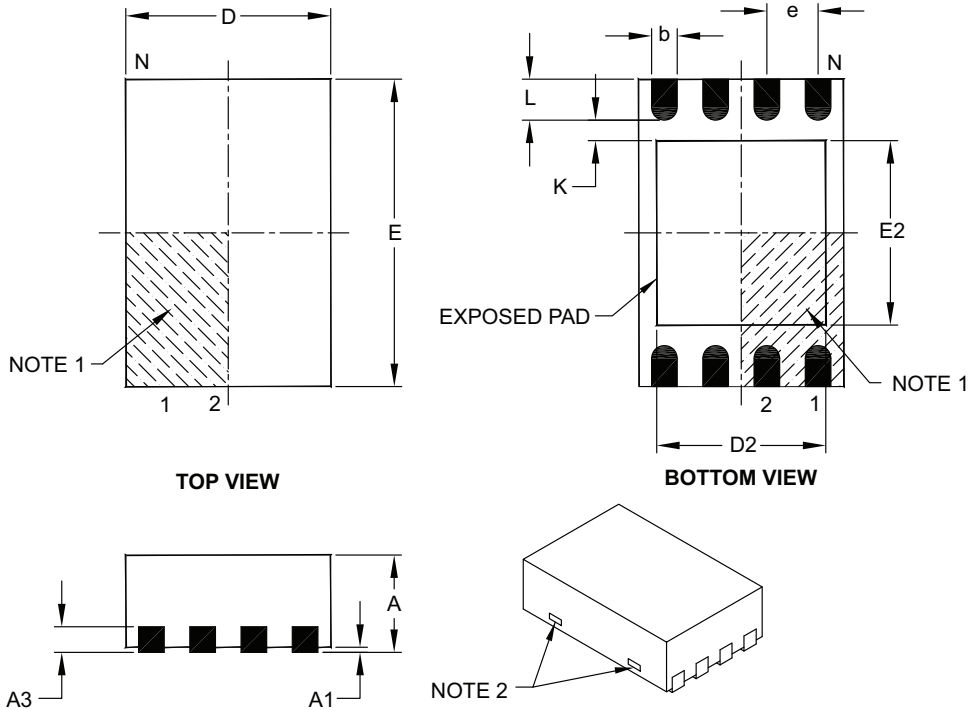

Dimension Limits	Units	MILLIMETERS		
		MIN	NOM	MAX
Number of Pins	N	8		
Pitch	e	0.50 BSC		
Overall Height	A	0.80	0.90	1.00
Standoff	A1	0.00	0.02	0.05
Contact Thickness	A3	0.20 REF		
Overall Length	D	2.00 BSC		
Overall Width	E	3.00 BSC		
Exposed Pad Length	D2	1.30	–	1.55
Exposed Pad Width	E2	1.50	–	1.75
Contact Width	b	0.20	0.25	0.30
Contact Length	L	0.30	0.40	0.50
Contact-to-Exposed Pad	K	0.20	–	–

Notes:

- Pin 1 visual index feature may vary, but must be located within the hatched area.
- Package may have one or more exposed tie bars at ends.
- Package is saw singulated.
- Dimensioning and tolerancing per ASME Y14.5M.

BSC: Basic Dimension. Theoretically exact value shown without tolerances.

REF: Reference Dimension, usually without tolerance, for information purposes only.

Microchip Technology Drawing C04-123C

8-Lead Plastic Dual Flat, No Lead Package (MC) - 2x3x0.9mm Body [DFN]

Note: For the most current package drawings, please see the Microchip Packaging Specification located at <http://www.microchip.com/packaging>

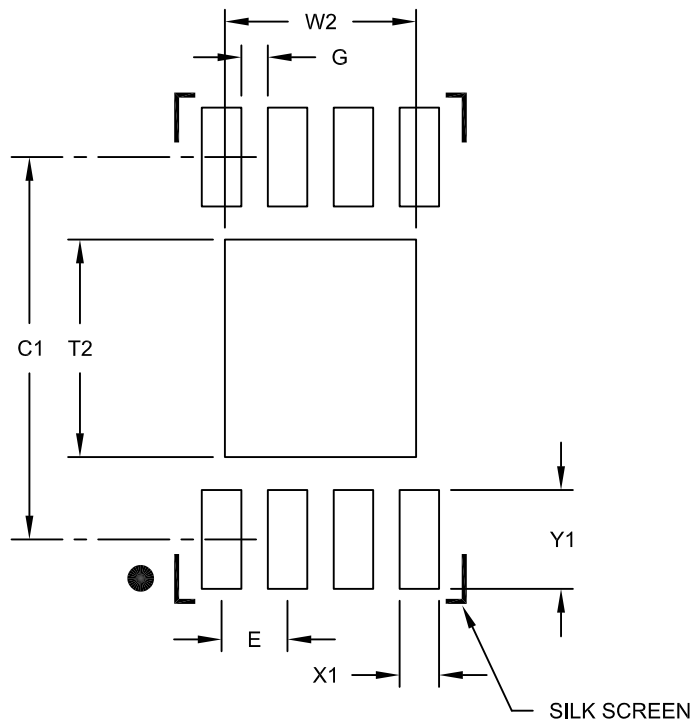

RECOMMENDED LAND PATTERN

Dimension Limits	Units	MILLIMETERS		
		MIN	NOM	MAX
Contact Pitch	E	0.50 BSC		
Optional Center Pad Width	W2			1.45
Optional Center Pad Length	T2			1.75
Contact Pad Spacing	C1		2.90	
Contact Pad Width (X8)	X1			0.30
Contact Pad Length (X8)	Y1			0.75
Distance Between Pads	G	0.20		

Notes:

1. Dimensioning and tolerancing per ASME Y14.5M

BSC: Basic Dimension. Theoretically exact value shown without tolerances.

Microchip Technology Drawing No. C04-2123B

MCP2003B

8-Lead Plastic Dual Flat, No Lead Package (MF) - 3x3x0.9mm Body [DFN]

Note: For the most current package drawings, please see the Microchip Packaging Specification located at <http://www.microchip.com/packaging>

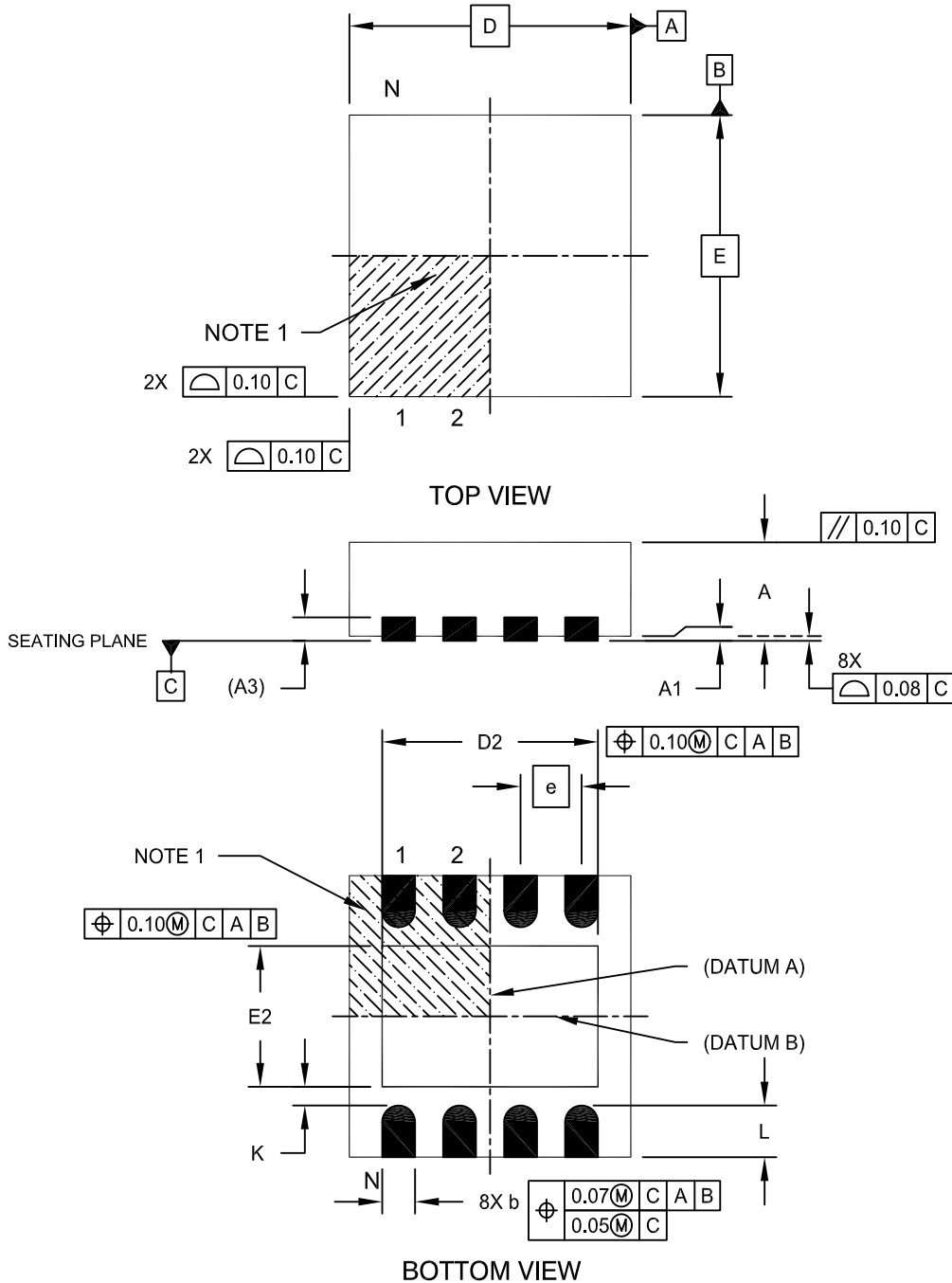

Microchip Technology Drawing No. C04-062C Sheet 1 of 2

8-Lead Plastic Dual Flat, No Lead Package (MF) - 3x3x0.9mm Body [DFN]

Note: For the most current package drawings, please see the Microchip Packaging Specification located at <http://www.microchip.com/packaging>

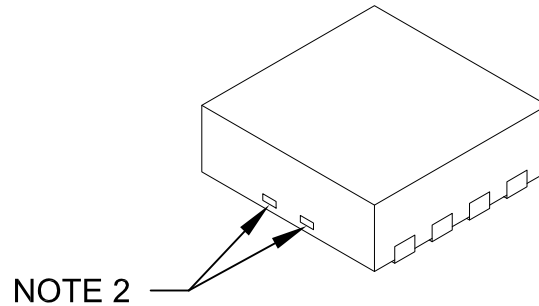

Dimension Limits	Units	MILLIMETERS		
		MIN	NOM	MAX
Number of Pins	N	8		
Pitch	e	0.65 BSC		
Overall Height	A	0.80	0.90	1.00
Standoff	A1	0.00	0.02	0.05
Contact Thickness	A3	0.20 REF		
Overall Length	D	3.00 BSC		
Exposed Pad Width	E2	1.34	-	1.60
Overall Width	E	3.00 BSC		
Exposed Pad Length	D2	1.60	-	2.40
Contact Width	b	0.25	0.30	0.35
Contact Length	L	0.20	0.30	0.55
Contact-to-Exposed Pad	K	0.20	-	-

Notes:

- Pin 1 visual index feature may vary, but must be located within the hatched area.
- Package may have one or more exposed tie bars at ends.
- Package is saw singulated
- Dimensioning and tolerancing per ASME Y14.5M

BSC: Basic Dimension. Theoretically exact value shown without tolerances.

REF: Reference Dimension, usually without tolerance, for information purposes only.

Microchip Technology Drawing No. C04-062C Sheet 2 of 2

MCP2003B

8-Lead Plastic Dual Flat, No Lead Package (MF) - 3x3x0.9mm Body [DFN]

Note: For the most current package drawings, please see the Microchip Packaging Specification located at <http://www.microchip.com/packaging>

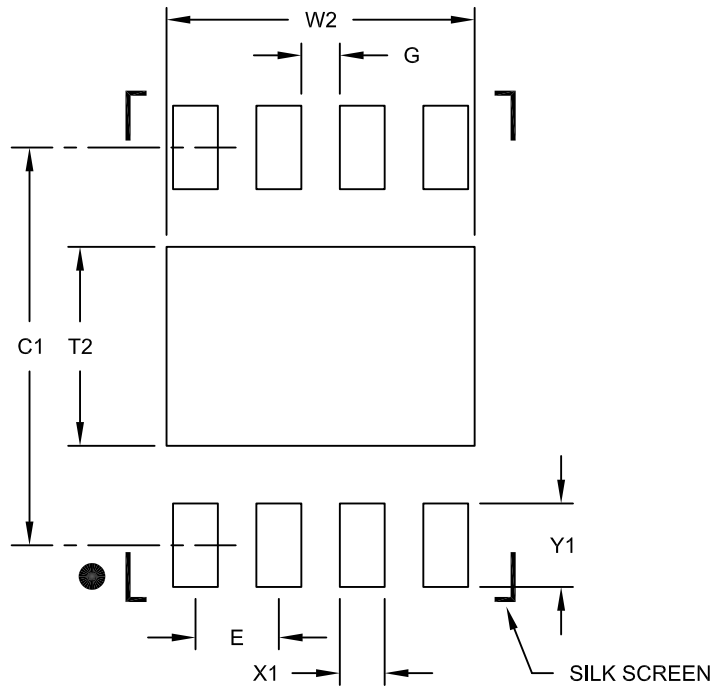

RECOMMENDED LAND PATTERN

Dimension Limits	Units	MILLIMETERS		
		MIN	NOM	MAX
Contact Pitch	E	0.65 BSC		
Optional Center Pad Width	W2			2.40
Optional Center Pad Length	T2			1.55
Contact Pad Spacing	C1		3.10	
Contact Pad Width (X8)	X1			0.35
Contact Pad Length (X8)	Y1			0.65
Distance Between Pads	G	0.30		

Notes:

1. Dimensioning and tolerancing per ASME Y14.5M

BSC: Basic Dimension. Theoretically exact value shown without tolerances.

Microchip Technology Drawing No. C04-2062B

MCP2003B

8-Lead Plastic Small Outline (SN) - Narrow, 3.90 mm Body [SOIC]

Note: For the most current package drawings, please see the Microchip Packaging Specification located at <http://www.microchip.com/packaging>

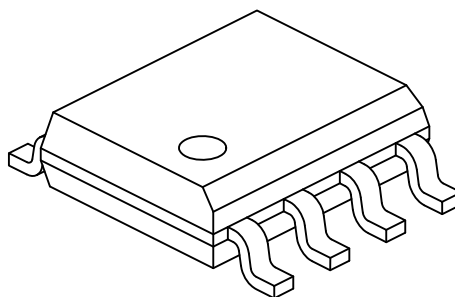

Dimension Limits	Units	MILLIMETERS		
		MIN	NOM	MAX
Number of Pins	N	8		
Pitch	e	1.27 BSC		
Overall Height	A	-	-	1.75
Molded Package Thickness	A2	1.25	-	-
Standoff §	A1	0.10	-	0.25
Overall Width	E	6.00 BSC		
Molded Package Width	E1	3.90 BSC		
Overall Length	D	4.90 BSC		
Chamfer (Optional)	h	0.25	-	0.50
Foot Length	L	0.40	-	1.27
Footprint	L1	1.04 REF		
Foot Angle	φ	0°	-	8°
Lead Thickness	c	0.17	-	0.25
Lead Width	b	0.31	-	0.51
Mold Draft Angle Top	α	5°	-	15°
Mold Draft Angle Bottom	β	5°	-	15°

Notes:

1. Pin 1 visual index feature may vary, but must be located within the hatched area.
2. § Significant Characteristic
3. Dimensions D and E1 do not include mold flash or protrusions. Mold flash or protrusions shall not exceed 0.15mm per side.
4. Dimensioning and tolerancing per ASME Y14.5M

BSC: Basic Dimension. Theoretically exact value shown without tolerances.

REF: Reference Dimension, usually without tolerance, for information purposes only.

Microchip Technology Drawing No. C04-057C Sheet 2 of 2

8-Lead Plastic Small Outline (SN) – Narrow, 3.90 mm Body [SOIC]

Note: For the most current package drawings, please see the Microchip Packaging Specification located at <http://www.microchip.com/packaging>

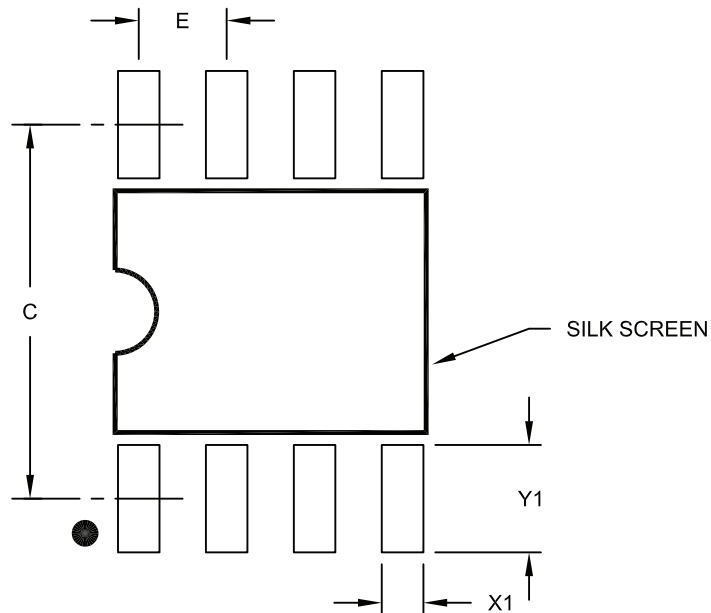

RECOMMENDED LAND PATTERN

Dimension Limits	Units	MILLIMETERS		
		MIN	NOM	MAX
Contact Pitch	E	1.27 BSC		
Contact Pad Spacing	C		5.40	
Contact Pad Width (X8)	X1			0.60
Contact Pad Length (X8)	Y1			1.55

Notes:

1. Dimensioning and tolerancing per ASME Y14.5M

BSC: Basic Dimension. Theoretically exact value shown without tolerances.

Microchip Technology Drawing No. C04-2057A

MCP2003B

NOTES:

APPENDIX A: REVISION HISTORY

Revision C (April 2016)

The following is the list of modifications:

- Updated [MCP2003B Block Diagram](#).
- Updated [Section 1.3.1, Power-Down Mode](#).
- Updated [Figure 1-2](#).
- Updated [Table 1-1](#).
- Added VBBUV_FALL, VBBUV_RISE and updated IBBPD.

Revision B (December 2015)

The following is the list of modifications:

- Included Features and Electrical Characteristics for the SAE J2962-1.
- Minor typographical changes.

Revision A (November 2015)

- Original release of this document.

MCP2003B

NOTES:

PRODUCT IDENTIFICATION SYSTEM

To order or obtain information, e.g., on pricing or delivery, refer to the factory or the listed sales office.

<u>PART NO.</u>	<u>X</u>	<u>/XX</u>
Device	Temperature Range	Package
<p>Device: MCP2003B: LIN Transceiver MCP2003BT: LIN Transceiver (Tape and Reel)</p> <p>Temperature Range: E = -40°C to +125°C (Extended) H = -40°C to +150°C (High)</p> <p>Package: MC = 8-Lead Plastic Dual Flat, No Lead Package – 2x3x0.9 mm Body (DFN) MF = 8-Lead Plastic Dual Flat, No Lead Package – 3x3x0.9 mm Body (DFN) SN = 8-Lead Plastic Small Outline – Narrow 3.90 mm Body (SOIC)</p>		
<p>Examples:</p> <p>a) MCP2003B-E/MC: Extended Temperature, 8LD 2x3 DFN package</p> <p>b) MCP2003B-E/MF: Extended Temperature, 8LD 3x3 DFN package</p> <p>c) MCP2003B-E/SN: Extended Temperature, 8LD SOIC package</p> <p>d) MCP2003BT-H/MC: Tape and Reel, High Temperature, 8LD 2x3 DFN package</p> <p>e) MCP2003BT-H/MF: Tape and Reel, High Temperature, 8LD 3x3 DFN package</p> <p>f) MCP2003BT-H/SN: Tape and Reel, High Temperature, 8LD SOIC package</p>		

MCP2003B

NOTES:

Note the following details of the code protection feature on Microchip devices:

- Microchip products meet the specification contained in their particular Microchip Data Sheet.
- Microchip believes that its family of products is one of the most secure families of its kind on the market today, when used in the intended manner and under normal conditions.
- There are dishonest and possibly illegal methods used to breach the code protection feature. All of these methods, to our knowledge, require using the Microchip products in a manner outside the operating specifications contained in Microchip's Data Sheets. Most likely, the person doing so is engaged in theft of intellectual property.
- Microchip is willing to work with the customer who is concerned about the integrity of their code.
- Neither Microchip nor any other semiconductor manufacturer can guarantee the security of their code. Code protection does not mean that we are guaranteeing the product as “unbreakable.”

Code protection is constantly evolving. We at Microchip are committed to continuously improving the code protection features of our products. Attempts to break Microchip's code protection feature may be a violation of the Digital Millennium Copyright Act. If such acts allow unauthorized access to your software or other copyrighted work, you may have a right to sue for relief under that Act.

Information contained in this publication regarding device applications and the like is provided only for your convenience and may be superseded by updates. It is your responsibility to ensure that your application meets with your specifications. MICROCHIP MAKES NO REPRESENTATIONS OR WARRANTIES OF ANY KIND WHETHER EXPRESS OR IMPLIED, WRITTEN OR ORAL, STATUTORY OR OTHERWISE, RELATED TO THE INFORMATION, INCLUDING BUT NOT LIMITED TO ITS CONDITION, QUALITY, PERFORMANCE, MERCHANTABILITY OR FITNESS FOR PURPOSE. Microchip disclaims all liability arising from this information and its use. Use of Microchip devices in life support and/or safety applications is entirely at the buyer's risk, and the buyer agrees to defend, indemnify and hold harmless Microchip from any and all damages, claims, suits, or expenses resulting from such use. No licenses are conveyed, implicitly or otherwise, under any Microchip intellectual property rights unless otherwise stated.

Microchip received ISO/TS-16949:2009 certification for its worldwide headquarters, design and wafer fabrication facilities in Chandler and Tempe, Arizona; Gresham, Oregon and design centers in California and India. The Company's quality system processes and procedures are for its PIC® MCUs and dsPIC® DSCs, KEELOQ® code hopping devices, Serial EEPROMs, microperipherals, nonvolatile memory and analog products. In addition, Microchip's quality system for the design and manufacture of development systems is ISO 9001:2000 certified.

QUALITY MANAGEMENT SYSTEM
CERTIFIED BY DNV
== ISO/TS 16949 ==

Trademarks

The Microchip name and logo, the Microchip logo, AnyRate, dsPIC, FlashFlex, flexPWR, Heldo, JukeBlox, KeeLoq, KeeLoq logo, Klear, LANCheck, LINK MD, MediaLB, MOST, MOST logo, MPLAB, OptoLyzer, PIC, PICSTART, PIC32 logo, RightTouch, SpyNIC, SST, SST Logo, SuperFlash and UNI/O are registered trademarks of Microchip Technology Incorporated in the U.S.A. and other countries.

ClockWorks, The Embedded Control Solutions Company, ETHERSYNCH, Hyper Speed Control, HyperLight Load, IntelliMOS, mTouch, Precision Edge, and QUIET-WIRE are registered trademarks of Microchip Technology Incorporated in the U.S.A.

Analog-for-the-Digital Age, Any Capacitor, AnyIn, AnyOut, BodyCom, chipKIT, chipKIT logo, CodeGuard, dsPICDEM, dsPICDEM.net, Dynamic Average Matching, DAM, ECAN, EtherGREEN, In-Circuit Serial Programming, ICSP, Inter-Chip Connectivity, JitterBlocker, KlearNet, KlearNet logo, MiWi, motorBench, MPASM, MPF, MPLAB Certified logo, MPLIB, MPLINK, MultiTRAK, NetDetach, Omniscient Code Generation, PICDEM, PICDEM.net, PICkit, PICtail, PureSilicon, RightTouch logo, REAL ICE, Ripple Blocker, Serial Quad I/O, SQL, SuperSwitcher, SuperSwitcher II, Total Endurance, TSHARC, USBCheck, VariSense, ViewSpan, WiperLock, Wireless DNA, and ZENA are trademarks of Microchip Technology Incorporated in the U.S.A. and other countries.

SQTP is a service mark of Microchip Technology Incorporated in the U.S.A.

Silicon Storage Technology is a registered trademark of Microchip Technology Inc. in other countries.

GestIC is a registered trademarks of Microchip Technology Germany II GmbH & Co. KG, a subsidiary of Microchip Technology Inc., in other countries.

All other trademarks mentioned herein are property of their respective companies.

© 2015-2016, Microchip Technology Incorporated, Printed in the U.S.A., All Rights Reserved.

ISBN: 978-1-5224-0505-4



MICROCHIP

Worldwide Sales and Service

AMERICAS

Corporate Office

2355 West Chandler Blvd.
Chandler, AZ 85224-6199

Tel: 480-792-7200

Fax: 480-792-7277

Technical Support:

[http://www.microchip.com/
support](http://www.microchip.com/support)

Web Address:

www.microchip.com

Atlanta

Duluth, GA

Tel: 678-957-9614

Fax: 678-957-1455

Austin, TX

Tel: 512-257-3370

Boston

Westborough, MA

Tel: 774-760-0087

Fax: 774-760-0088

Chicago

Itasca, IL

Tel: 630-285-0071

Fax: 630-285-0075

Cleveland

Independence, OH

Tel: 216-447-0464

Fax: 216-447-0643

Dallas

Addison, TX

Tel: 972-818-7423

Fax: 972-818-2924

Detroit

Novi, MI

Tel: 248-848-4000

Houston, TX

Tel: 281-894-5983

Indianapolis

Noblesville, IN

Tel: 317-773-8323

Fax: 317-773-5453

Los Angeles

Mission Viejo, CA

Tel: 949-462-9523

Fax: 949-462-9608

New York, NY

Tel: 631-435-6000

San Jose, CA

Tel: 408-735-9110

Canada - Toronto

Tel: 905-673-0699

Fax: 905-673-6509

ASIA/PACIFIC

Asia Pacific Office

Suites 3707-14, 37th Floor
Tower 6, The Gateway
Harbour City, Kowloon

Hong Kong

Tel: 852-2943-5100

Fax: 852-2401-3431

Australia - Sydney

Tel: 61-2-9868-6733

Fax: 61-2-9868-6755

China - Beijing

Tel: 86-10-8569-7000

Fax: 86-10-8528-2104

China - Chengdu

Tel: 86-28-8665-5511

Fax: 86-28-8665-7889

China - Chongqing

Tel: 86-23-8980-9588

Fax: 86-23-8980-9500

China - Dongguan

Tel: 86-769-8702-9880

China - Hangzhou

Tel: 86-571-8792-8115

Fax: 86-571-8792-8116

China - Hong Kong SAR

Tel: 852-2943-5100

Fax: 852-2401-3431

China - Nanjing

Tel: 86-25-8473-2460

Fax: 86-25-8473-2470

China - Qingdao

Tel: 86-532-8502-7355

Fax: 86-532-8502-7205

China - Shanghai

Tel: 86-21-5407-5533

Fax: 86-21-5407-5066

China - Shenyang

Tel: 86-24-2334-2829

Fax: 86-24-2334-2393

China - Shenzhen

Tel: 86-755-8864-2200

Fax: 86-755-8203-1760

China - Wuhan

Tel: 86-27-5980-5300

Fax: 86-27-5980-5118

China - Xian

Tel: 86-29-8833-7252

Fax: 86-29-8833-7256

ASIA/PACIFIC

China - Xiamen

Tel: 86-592-2388138

Fax: 86-592-2388130

China - Zhuhai

Tel: 86-756-3210040

Fax: 86-756-3210049

India - Bangalore

Tel: 91-80-3090-4444

Fax: 91-80-3090-4123

India - New Delhi

Tel: 91-11-4160-8631

Fax: 91-11-4160-8632

India - Pune

Tel: 91-20-3019-1500

Japan - Osaka

Tel: 81-6-6152-7160

Fax: 81-6-6152-9310

Japan - Tokyo

Tel: 81-3-6880-3770

Fax: 81-3-6880-3771

Korea - Daegu

Tel: 82-53-744-4301

Fax: 82-53-744-4302

Korea - Seoul

Tel: 82-2-554-7200

Fax: 82-2-558-5932 or

82-2-558-5934

Malaysia - Kuala Lumpur

Tel: 60-3-6201-9857

Fax: 60-3-6201-9859

Malaysia - Penang

Tel: 60-4-227-8870

Fax: 60-4-227-4068

Philippines - Manila

Tel: 63-2-634-9065

Fax: 63-2-634-9069

Singapore

Tel: 65-6334-8870

Fax: 65-6334-8850

Taiwan - Hsin Chu

Tel: 886-3-5778-366

Fax: 886-3-5770-955

Taiwan - Kaohsiung

Tel: 886-7-213-7828

Taiwan - Taipei

Tel: 886-2-2508-8600

Fax: 886-2-2508-0102

Thailand - Bangkok

Tel: 66-2-694-1351

Fax: 66-2-694-1350

EUROPE

Austria - Wels

Tel: 43-7242-2244-39

Fax: 43-7242-2244-393

Denmark - Copenhagen

Tel: 45-4450-2828

Fax: 45-4485-2829

France - Paris

Tel: 33-1-69-53-63-20

Fax: 33-1-69-30-90-79

Germany - Dusseldorf

Tel: 49-2129-3766400

Germany - Karlsruhe

Tel: 49-721-625370

Germany - Munich

Tel: 49-89-627-144-0

Fax: 49-89-627-144-44

Italy - Milan

Tel: 39-0331-742611

Fax: 39-0331-466781

Italy - Venice

Tel: 39-049-7625286

Netherlands - Drunen

Tel: 31-416-690399

Fax: 31-416-690340

Poland - Warsaw

Tel: 48-22-3325737

Spain - Madrid

Tel: 34-91-708-08-90

Fax: 34-91-708-08-91

Sweden - Stockholm

Tel: 46-8-5090-4654

UK - Wokingham

Tel: 44-118-921-5800

Fax: 44-118-921-5820

07/14/15

Looking for pricing, stock, or lifecycle information?

Click below to explore more details on WIN SOURCE:

- ⊖ [View MCP2003B-H/SN on WIN SOURCE](#)
- ⊖ [Microchip Technology](#) Information

Optimize Your Supply Chain with WIN SOURCE Solutions

- ✓ Global Sourcing Solution
- ✓ Obsolete Management
- ✓ Cost Control Management
- ✓ Shortage Management
- ✓ Alternative Solution
- ✓ Excess Inventory Management