

Film Capacitors

Metallized Polypropylene Film Capacitors (MKP)

Series/Type: B32754 ... B32758

Date: February 2021

MKP AC filtering
Typical applications

- Output AC filtering for power converters, UPS, motor drives

Climatic

- Max. operating temperature: 105 °C
- Climatic category (IEC 60068-1:2013): 40/105/56

Construction

- Dielectric: Polypropylene (PP)
- Plastic case (UL 94 V-0)
- Epoxy resin sealing (UL 94 V-0)

Features

- THB Grade III Test A (refer to IEC60384-14:2013/AMD1:2016)
- Optimized AC voltage performance
- High ripple current/frequency handling capability
- AEC-Q200D compliant
- UL 810 construction
- For PCB mounting

Terminals

- Parallel wire leads, lead-free tinned
- 2-pin and 4-pin versions
- Standard lead lengths: 6 – 1 mm
- Special lead lengths available on request

Marking

Manufacturer's logo, lot number, series number, rated capacitance (code), capacitance tolerance (code with letter), rated AC voltage, date of manufacture (code), approval

Delivery mode

Bulk (untaped, lead length 6 – 1 mm)

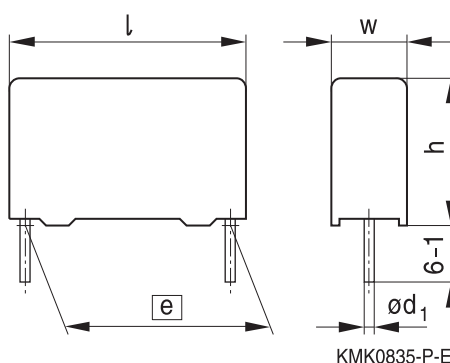
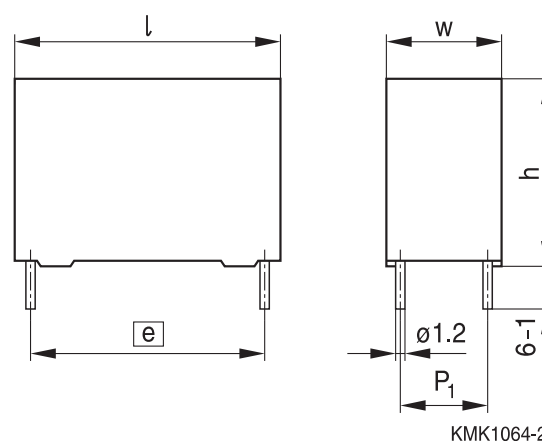
Dimensional drawings
2-pin version

4-pin version

Dimensions in mm

Version	Lead spacing $e \pm 0.4$	Lead diameter $d_1 \pm 0.05$	Type
2-pin	27.5	0.8	B32754C
2-pin	37.5	1.0	B32756C
4-pin	37.5	1.0 ¹⁾ /1.2	B32756G
4-pin	52.5	1.2	B32758G

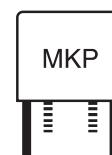
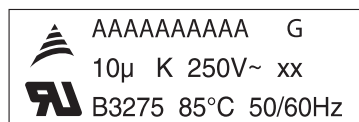
1) For box dimensions 22.0 × 45.0 × 42.0 mm

Marking example (position of marks can vary)

Ordering code examples

B	3275	4	C	3	105	K
Components class	Series	Lead space (mm)	Pin number	Rated voltage	Rated capacitance	Capacitance tolerance
Passive components	MKP	4 = 27.5 6 = 37.5 8 = 52.5	C = 2 pins G = 4 pins	2 = 250 V AC 3 = 310 V AC 4 = 400 V AC 7 = 275 V AC 8 = 350 V AC	105 = 1000 nF = 1.0 µF	J = ±5% K = ±10% + = K or J

Voltage ratings

$V_{R, DC}$	500 V DC	550 V DC	580 V DC	580 V DC	800 V DC
$V_{R, AC}$	350 V AC	380 V AC	430 V AC	480 V AC	560 V AC
V_{RMS}	250 V AC	275 V AC	310 V AC	350 V AC	400 V AC

Note:

$V_{R, AC}$ is maximum operating peak recurrent voltage of either polarity of a reversing type waveform, not an RMS value.

Approval

Approval mark	Standards	Certificate
	UL 810 (construction only)	E323128, Vol 1

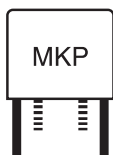

B32754 ... B32758

MKP AC filtering

Overview of available types

Lead spacing	27.5 mm					37.5 mm					52.5 mm				
Type	B32754					B32756					B32758				
Page	5					7					9				
V _{RMS} (V AC)	250	275	310	350	400	250	275	310	350	400	250	275	310	350	400
C _R (μF)															
1.0															
1.5															
2.0															
2.5															
3.0															
3.5															
4.0															
4.5															
5.0															
6.0															
7.0															
8.0															
9.0															
10															
12															
14															
15															
20															
22															
25															
30															
33															
35															
40															
45															
50															
55															
60															
65															
70															

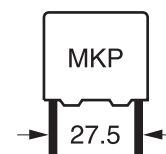
Ordering codes and packing units (lead spacing 27.5 mm)

V_{RMS}	V_R	$C_R^{1)}$	Max. dimensions $w \times h \times l$	P_1	Ordering code (composition see below)	$I_{RMS}^{2)}$ 85 °C 10 kHz A	ESR_{typ} 10 kHz mΩ	Untaped pcs./MOQ
V AC	V DC	μF	mm	mm				
250	500	1.0	11.0 × 19.0 × 31.5	—	B32754C2105+000	3.5	21.9	2352
		2.0	12.5 × 21.5 × 31.5	—	B32754C2205+000	5.0	12.2	2100
		3.0	14.0 × 24.5 × 31.5	—	B32754C2305K000	6.5	8.7	1848
		4.0	16.0 × 32.0 × 31.5	—	B32754C2405+000	8.5	6.1	1064
		5.0	16.0 × 32.0 × 31.5	—	B32754C2505+000	9.0	5.4	1064
		6.0	18.0 × 33.0 × 31.5	—	B32754C2605+000	10.5	4.6	952
		7.0	22.0 × 36.5 × 31.5	—	B32754C2705+000	12.5	3.8	784
		8.0	22.0 × 36.5 × 31.5	—	B32754C2805+000	13.0	3.6	784
		9.0	22.0 × 36.5 × 31.5	—	B32754C2905+000	13.5	3.4	784
		10	22.0 × 36.5 × 31.5	—	B32754C2106K000	13.5	3.2	784
		12	22.0 × 48.0 × 31.5	—	B32754C2126+000	14.0	3.0	320
		14	22.0 × 48.0 × 31.5	—	B32754C2146K000	14.0	2.8	320
275	550	1.0	11.0 × 19.0 × 31.5	—	B32754C7105+000	3.5	21.3	2352
		1.5	12.5 × 21.5 × 31.5	—	B32754C7155+000	4.5	14.4	2100
		2.0	13.5 × 23.0 × 31.5	—	B32754C7205+000	5.5	10.9	1932
		2.5	15.0 × 24.5 × 31.5	—	B32754C7255+000	6.5	8.9	1680
		3.0	16.0 × 32.0 × 31.5	—	B32754C7305+000	8.0	7.1	1064
		4.0	16.0 × 32.0 × 31.5	—	B32754C7405+000	8.5	6.0	1064
		5.0	18.0 × 33.0 × 31.5	—	B32754C7505K000	10.0	5.0	952
		6.0	22.0 × 36.5 × 31.5	—	B32754C7605+000	12.0	4.1	784
		7.0	22.0 × 36.5 × 31.5	—	B32754C7705+000	12.5	3.7	784
		8.0	22.0 × 48.0 × 31.5	—	B32754C7805+000	13.0	3.4	320
		9.0	22.0 × 48.0 × 31.5	—	B32754C7905+000	13.5	3.4	320
		10	22.0 × 48.0 × 31.5	—	B32754C7106+000	14.0	3.1	320

MOQ = Minimum Order Quantity, consisting of 4 packing units.

Further E series and intermediate capacitance values on request.

Composition of ordering code

+ = Capacitance tolerance code:

K = ±10%

J = ±5%

1) Capacitance value measured at 1 kHz

2) Max. ripple current I_{RMS} at 85 °C, 10 kHz for $\Delta T \leq 15$ °C at $\Delta ESR_{typ} \leq \pm 5$ %

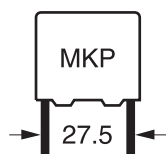
B32754
MKP AC filtering
Ordering codes and packing units (lead spacing 27.5 mm)

V_{RMS}	V_R	$C_R^{3)}$	Max. dimensions $w \times h \times l$	P_1	Ordering code (composition see below)	$I_{RMS}^{4)}$ 85 °C 10 kHz A	ESR_{typ} 10 kHz mΩ	Untaped pcs./MOQ
V AC	V DC	μF	mm	mm				
310	580	1.0	11.0 × 21.0 × 31.5	—	B32754C3105+000	4.0	20.3	2352
		1.5	13.5 × 23.0 × 31.5	—	B32754C3155+000	5.0	13.6	1932
		2.0	14.0 × 24.5 × 31.5	—	B32754C3205K000	6.0	10.9	1848
		2.5	16.0 × 32.0 × 31.5	—	B32754C3255+000	7.0	8.3	1064
		3.0	18.0 × 27.5 × 31.5	—	B32754C3305+000	8.0	7.0	1428
		3.5	18.0 × 33.0 × 31.5	—	B32754C3355+000	9.0	6.2	952
		4.0	19.0 × 30.0 × 31.5	—	B32754C3405K000	9.5	5.8	896
		4.5	21.0 × 31.0 × 31.5	—	B32754C3455+000	10.0	5.1	784
		5.0	22.0 × 36.5 × 31.5	—	B32754C3505+000	11.0	4.6	784
		6.0	22.0 × 36.5 × 31.5	—	B32754C3605K000	12.0	4.1	784
		7.0	22.0 × 48.0 × 31.5	—	B32754C3705+000	13.0	4.0	320
		8.0	22.0 × 48.0 × 31.5	—	B32754C3805+000	14.0	3.4	320
		9.0	22.0 × 48.0 × 31.5	—	B32754C3905K000	14.0	3.3	320
350	580	1.0	11.0 × 21.0 × 31.5	—	B32754C8105+000	5.0	11.7	2352
		1.5	13.5 × 23.0 × 31.5	—	B32754C8155+000	6.0	8.0	1932
		2.0	15.0 × 24.5 × 31.5	—	B32754C8205K000	7.5	6.4	1680
		2.5	16.0 × 32.0 × 31.5	—	B32754C8255+000	9.0	5.0	1064
		3.0	18.0 × 33.0 × 31.5	—	B32754C8305+000	10.5	4.3	952
		3.5	18.0 × 33.0 × 31.5	—	B32754C8355+000	11.0	3.9	952
		4.0	21.0 × 31.0 × 31.5	—	B32754C8405K000	11.5	3.6	784
		4.5	22.0 × 36.5 × 31.5	—	B32754C8455+000	12.0	3.2	784
		5.0	22.0 × 36.5 × 31.5	—	B32754C8505+000	13.0	3.0	784
		6.0	22.0 × 48.0 × 31.5	—	B32754C8605+000	14.0	2.8	320
		7.0	22.0 × 48.0 × 31.5	—	B32754C8705+000	14.0	2.6	320
400	800	1.0	14.0 × 24.5 × 31.5	—	B32754C4105K000	6.0	9.5	1848
		1.5	18.0 × 27.5 × 31.5	—	B32754C4155+000	8.0	6.4	1428
		2.0	21.0 × 31.0 × 31.5	—	B32754C4205+000	10.0	4.9	784
		2.5	22.0 × 36.5 × 31.5	—	B32754C4255+000	12.0	4.2	784
		3.0	22.0 × 36.5 × 31.5	—	B32754C4305K000	13.0	3.8	784
		4.0	22.0 × 48.0 × 31.5	—	B32754C4405+000	14.0	3.2	320

MOQ = Minimum Order Quantity, consisting of 4 packing units.

Further E series and intermediate capacitance values on request.

Composition of ordering code

+ = Capacitance tolerance code:

K = ±10%

J = ±5%

3) Capacitance value measured at 1 kHz

4) Max. ripple current I_{RMS} at 85 °C, 10 kHz for $\Delta T \leq 15$ °C at $\Delta ESR_{typ} \leq \pm 5$ %

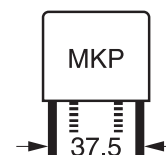
Ordering codes and packing units (lead spacing 37.5 mm)

V_{RMS}	V_R	$C_R^{1)}$	Max. dimensions $w \times h \times l$	P_1	Ordering code (composition see below)	$I_{RMS}^{2)}$ 85 °C 10 kHz A	ESR_{typ} 10 kHz mΩ	Untaped pcs./MOQ
V AC	V DC	μF	mm	mm				
250	500	5.0	18.0 × 32.5 × 42.0	—	B32756C2505+000	8.0	7.6	720
		6.0	18.0 × 32.5 × 42.0	—	B32756C2605+000	9.0	6.5	720
		7.0	18.0 × 32.5 × 42.0	—	B32756C2705+000	9.0	6.1	720
		8.0	18.0 × 32.5 × 42.0	—	B32756C2805+000	10.0	5.9	720
		9.0	18.0 × 32.5 × 42.0	—	B32756C2905+000	10.5	5.3	720
		10	20.0 × 39.5 × 42.0	10.2	B32756G2106+000	13.0	4.1	640
		12	20.0 × 39.5 × 42.0	10.2	B32756G2126+000	14.0	3.8	640
		15	22.0 × 45.0 × 42.0	10.2	B32756G2156+000	15.0	3.2	560
		20	28.0 × 42.5 × 42.0	10.2	B32756G2206+000	19.0	2.4	440
		22	30.0 × 45.0 × 42.0	20.3	B32756G2226+000	21.0	2.2	400
		25	33.0 × 48.0 × 42.0	20.3	B32756G2256+000	23.0	2.0	180
		30	33.0 × 48.0 × 42.0	20.3	B32756G2306K000	24.0	1.8	180
275	550	5.0	18.0 × 32.5 × 42.0	—	B32756C7505+000	8.0	7.6	720
		6.0	18.0 × 32.5 × 42.0	—	B32756C7605+000	9.0	6.5	720
		7.0	18.0 × 32.5 × 42.0	—	B32756C7705+000	9.0	6.1	720
		8.0	20.0 × 39.5 × 42.0	10.2	B32756G7805+000	12.0	4.7	640
		9.0	20.0 × 39.5 × 42.0	10.2	B32756G7905+000	13.0	4.3	640
		10	20.0 × 39.5 × 42.0	10.2	B32756G7106+000	13.0	4.1	640
		12	22.0 × 45.0 × 42.0	10.2	B32756G7126+000	14.0	3.6	560
		15	28.0 × 42.5 × 42.0	10.2	B32756G7156+000	18.0	2.8	440
		20	30.0 × 45.0 × 42.0	20.3	B32756G7206K000	20.0	2.3	400
		22	33.0 × 48.0 × 42.0	20.3	B32756G7226+000	23.0	2.0	180

MOQ = Minimum Order Quantity, consisting of 4 packing units.

Further E series and intermediate capacitance values on request.

Composition of ordering code

+ = Capacitance tolerance code:

K = ±10%

J = ±5%

1) Capacitance value measured at 1 kHz

2) Max. ripple current I_{RMS} at 85 °C, 10 kHz for $\Delta T \leq 15$ °C at $\Delta ESR_{typ} \leq \pm 5$ %

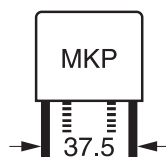
B32756
MKP AC filtering
Ordering codes and packing units (lead spacing 37.5 mm)

V_{RMS}	V_R	$C_R^{3)}$	Max. dimensions $w \times h \times l$	P_1	Ordering code (composition see below)	$I_{RMS}^{4)}$ 85 °C 10 kHz A	ESR_{typ} 10 kHz mΩ	Untaped pcs./MOQ
V AC	V DC	μF	mm	mm				
310	580	5.0	18.0 × 32.5 × 42.0	—	B32756C3505+000	9.0	7.6	720
		6.0	18.0 × 32.5 × 42.0	—	B32756C3605+000	9.5	6.4	720
		7.0	20.0 × 39.5 × 42.0	10.2	B32756G3705+000	12.0	5.3	640
		8.0	20.0 × 39.5 × 42.0	10.2	B32756G3805+000	12.5	4.7	640
		9.0	20.0 × 39.5 × 42.0	10.2	B32756G3905+000	13.0	4.3	640
		10	22.0 × 45.0 × 42.0	10.2	B32756G3106+000	14.0	3.9	560
		12	22.0 × 45.0 × 42.0	10.2	B32756G3126K000	14.5	3.5	560
		14	28.0 × 42.5 × 42.0	10.2	B32756G3146K000	17.0	2.9	440
		15	30.0 × 45.0 × 42.0	20.3	B32756G3156+000	19.0	2.6	400
		20	33.0 × 48.0 × 42.0	20.3	B32756G3206K000	22.0	2.2	180
350	580	5.0	18.0 × 32.5 × 42.0	—	B32756C8505+000	12.0	4.3	720
		6.0	20.0 × 39.5 × 42.0	10.2	B32756G8605+000	15.0	3.4	640
		7.0	20.0 × 39.5 × 42.0	10.2	B32756G8705+000	16.0	3.0	640
		8.0	22.0 × 45.0 × 42.0	10.2	B32756G8805+000	17.0	2.7	560
		9.0	22.0 × 45.0 × 42.0	10.2	B32756G8905+000	18.0	2.5	560
		10	28.0 × 42.5 × 42.0	10.2	B32756G8106+000	20.0	2.1	440
		12	30.0 × 45.0 × 42.0	20.3	B32756G8126+000	23.0	1.8	400
15	33.0 × 48.0 × 42.0	20.3	B32756G8156+000	26.0	1.5	180		
400	800	1.0	12.0 × 22.0 × 42.0	—	B32756C4105K000	5.0	15.2	1620
		2.0	16.0 × 28.5 × 42.0	—	B32756C4205+000	8.0	7.7	800
		3.0	18.0 × 32.5 × 42.0	—	B32756C4305K000	10.0	5.5	720
		4.0	20.0 × 39.5 × 42.0	10.2	B32756G4405+000	13.5	3.8	640
		5.0	22.0 × 45.0 × 42.0	10.2	B32756G4505+000	15.0	3.2	560
		6.0	28.0 × 42.5 × 42.0	10.2	B32756G4605+000	18.5	2.6	440
		7.0	30.0 × 45.0 × 42.0	20.3	B32756G4705+000	20.5	2.3	400
		8.0	33.0 × 48.0 × 42.0	20.3	B32756G4805+000	23.0	2.0	180
		9.0	33.0 × 48.0 × 42.0	20.3	B32756G4905K000	24.0	1.9	180

MOQ = Minimum Order Quantity, consisting of 4 packing units.

Further E series and intermediate capacitance values on request.

Composition of ordering code

+ = Capacitance tolerance code:

K = ±10%

J = ±5%

3) Capacitance value measured at 1 kHz

4) Max. ripple current I_{RMS} at 85 °C, 10 kHz for $\Delta T \leq 15$ °C at $\Delta ESR_{typ} \leq \pm 5$ %

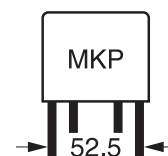
Ordering codes and packing units (lead spacing 52.5 mm)

V_{RMS}	V_R	$C_R^{1)}$	Max. dimensions $w \times h \times l$	P_1	Ordering code (composition see below)	$I_{RMS}^{2)}$ 85 °C 10 kHz A	ESR_{typ} 10 kHz mΩ	Untaped pcs./MOQ
V AC	V DC	μF	mm	mm				
250	500	20	30.0 × 45.0 × 57.5	20.3	B32758G2206+000	18.0	3.7	280
		22	30.0 × 45.0 × 57.5	20.3	B32758G2226+000	19.0	3.4	280
		25	30.0 × 45.0 × 57.5	20.3	B32758G2256+000	19.5	3.3	280
		30	30.0 × 45.0 × 57.5	20.3	B32758G2306+000	20.0	3.1	280
		35	30.0 × 45.0 × 57.5	20.3	B32758G2356K000	21.0	2.8	280
		40	35.0 × 50.0 × 57.5	20.3	B32758G2406+000	24.0	2.4	108
		45	35.0 × 50.0 × 57.5	20.3	B32758G2456K000	25.0	2.2	108
		50	38.0 × 57.5 × 57.5	20.3	B32758G2506+000	27.0	2.0	96
		55	38.0 × 57.5 × 57.5	20.3	B32758G2556+000	28.0	1.8	96
		60	38.0 × 57.5 × 57.5	20.3	B32758G2606K000	29.0	1.8	96
275	550	20	30.0 × 45.0 × 57.5	20.3	B32758G7206+000	17.0	3.7	280
		22	30.0 × 45.0 × 57.5	20.3	B32758G7226+000	18.0	3.4	280
		25	30.0 × 45.0 × 57.5	20.3	B32758G7256+000	19.0	3.3	280
		30	35.0 × 50.0 × 57.5	20.3	B32758G7306+000	22.0	2.6	108
		35	35.0 × 50.0 × 57.5	20.3	B32758G7356+000	23.0	2.4	108
		40	38.0 × 57.5 × 57.5	20.3	B32758G7406+000	26.0	2.1	96
		45	38.0 × 57.5 × 57.5	20.3	B32758G7456+000	27.0	2.0	96
		50	45.0 × 57.0 × 57.5	20.3	B32758G7506+000	30.0	1.8	140
310	580	20	30.0 × 45.0 × 57.5	20.3	B32758G3206+000	19.0	3.7	280
		22	30.0 × 45.0 × 57.5	20.3	B32758G3226+000	20.0	3.4	280
		25	35.0 × 50.0 × 57.5	20.3	B32758G3256+000	22.0	3.0	108
		30	35.0 × 50.0 × 57.5	20.3	B32758G3306+000	23.0	2.6	108
		35	38.0 × 57.5 × 57.5	20.3	B32758G3356+000	26.0	2.3	96
		40	38.0 × 57.5 × 57.5	20.3	B32758G3406K000	28.0	2.1	96
		45	45.0 × 57.5 × 57.5	20.3	B32758G3456+000	30.0	1.9	140

MOQ = Minimum Order Quantity, consisting of 4 packing units.

Further E series and intermediate capacitance values on request.

Composition of ordering code

+ = Capacitance tolerance code:

K = ±10%

J = ±5%

1) Capacitance value measured at 1 kHz

2) Max. ripple current I_{RMS} at 85 °C, 10 kHz for $\Delta T \leq 15$ °C at $\Delta ESR_{typ} \leq \pm 5$ %

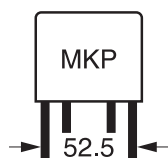

B32758

MKP AC filtering

Ordering codes and packing units (lead spacing 52.5 mm)

V_{RMS}	V_R	$C_R^{3)}$	Max. dimensions $w \times h \times l$	P_1	Ordering code (composition see below)	$I_{RMS}^{4)}$ 85 °C 10 kHz A	ESR_{typ} 10 kHz mΩ	Untaped pcs./MOQ
V AC	V DC	μF	mm	mm				
350	580	15	30.0 × 45.0 × 57.5	20.3	B32758G8156+000	21.0	2.6	280
		20	35.0 × 50.0 × 57.5	20.3	B32758G8206+000	26.0	2.0	108
		22	35.0 × 50.0 × 57.5	20.3	B32758G8226+000	27.0	1.9	108
		25	35.0 × 50.0 × 57.5	20.3	B32758G8256K000	28.0	1.8	108
		30	38.0 × 57.5 × 57.5	20.3	B32758G8306+000	29.0	1.5	96
		33	38.0 × 57.5 × 57.5	20.3	B32758G8336K000	30.0	1.4	96
		35	45.0 × 57.5 × 57.5	20.3	B32758G8356+000	32.0	1.3	140
400	800	9.0	30.0 × 45.0 × 57.5	20.3	B32758G4905+000	20.0	3.0	280
		10	30.0 × 45.0 × 57.5	20.3	B32758G4106+000	21.0	2.8	280
		12	35.0 × 50.0 × 57.5	20.3	B32758G4126+000	25.0	2.3	108
		15	38.0 × 57.5 × 57.5	20.3	B32758G4156+000	28.0	1.9	96
		20	45.0 × 57.5 × 57.5	20.3	B32758G4206+000	32.0	1.6	140

MOQ = Minimum Order Quantity, consisting of 4 packing units.

Further E series and intermediate capacitance values on request.

Composition of ordering code

+ = Capacitance tolerance code:

K = ±10%

J = ±5%

3) Capacitance value measured at 1 kHz

4) Max. ripple current I_{RMS} at 85 °C, 10 kHz for $\Delta T \leq 15$ °C at $\Delta ESR_{typ} \leq \pm 5$ %



Technical data

Reference standard: IEC 61071:2007, all data given at T = 20 °C unless otherwise specified.

Operating temperature range (case)	Upper category temperature, $T_{op,max}$ +105 °C Rated temperature T_{max} +85 °C Lower category temperature T_{min} -40 °C Note: At T > 85 °C derating for V_{RMS} or V_R should be 1.5%/°C
Dissipation factor $\tan \delta$ (in 10^{-3}) at 20 °C and 1kHz (upper limit values)	1.0, $C_R \leq 55 \mu F$ 1.2, $C_R > 55 \mu F$
Insulation resistance R_{ins} after 1min, given as time constant $\tau = C_R \cdot R_{ins}$, (Minimum as-delivered values with rel. humidity $\leq 65\%$) Measuring voltage: 500 V DC	10 000 s
DC test voltage between terminals	$1.5 \cdot V_R$ for 10 s or $1.6 \cdot V_R$ for 2 s
Test voltage between terminal to case	2000 V AC at 50/60Hz Hz, 60 s (typical test)
Maximum peak current (A)	$I_{P,max} = C_R \cdot \frac{dV}{dt}$
THB to high robustness under high humidity, refer to IEC 60384-14:2013/AMD1:2016 Grade III Test A	Temperature T: 60 °C ± 2 °C Relative humidity: 95% $\pm 2\%$ Applied voltage: V_{RMS} (50/60Hz) Test duration: 1344 h
Criteria for passing THB test	Capacitance change $ \Delta C/C_0 \leq 10\%$ Dissipation factor change $\Delta \tan \delta \leq 0.005$ Insulation resistance $R_{ins} \geq 50\%$ specified limit
Change of temperature	In accordance with IEC 60068-2-14:2009 (Test Nb)
Reliability: Failure rate λ Service life t_{SL}	10 fit ($< 10 \times 10^{-9}/h$) at $0.5 \times V_{RMS}$, 40 °C $\geq 60\,000$ h at V_{RMS} (50/60Hz) at 70 °C For conversion to other operating conditions and temperatures, refer to chapter "Quality, 2 Reliability".
Failure criteria: Total failure Failure due to variation of parameters	Short/open circuit Capacitance change $ \Delta C/C_0 \geq 10\%$ Dissipation factor change $\Delta \tan \delta > 4 \cdot$ upper limit values Insulation resistance R_{ins} or time constant $\tau = C_R \cdot R_{ins} < 500$ s

Note:

1000 hrs / 85 °C / 85% relative humidity with V_{RMS} available on request, based on special design.

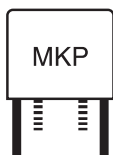

B32754 ... B32758

MKP AC filtering

Pulse handling capability

"dV/dt" represents the maximum permissible voltage change per unit of time for non-sinusoidal voltages, expressed in V/μs.

"k0" represents the maximum permissible pulse characteristic of the waveform applied to the capacitor, expressed in V²/μs.

Note:

The values of dV/dt and k0 provided below must not be exceeded in order to avoid damaging the capacitor. These parameters are given for isolated pulses in such a way that the heat generated by one pulse will be completely dissipated before applying the next pulse. For a train of pulses, please refer to the curves of permissible AC voltage-current versus frequency

Lead spacing	27.5 mm					37.5 mm				
Type	B32754					B32756				
V _R (V DC)	500	550	580	580	800	500	550	580	580	800
V _{RMS} (V AC)	250	275	310	350	400	250	275	310	350	400
	dV/dt in V/μs									
	50	55	68	80	100	25	30	35	50	60

Lead spacing	52.5 mm				
Type	B32758				
V _R (V DC)	500	550	580	580	800
V _{RMS} (V AC)	250	275	310	350	400
	dV/dt in V/μs				
	13	15	17	25	30

Impedance Z versus frequency f (typical values)

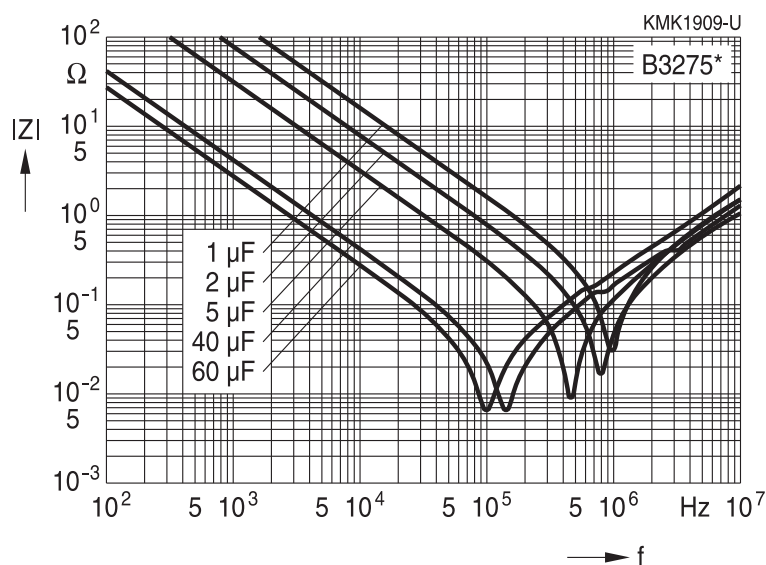

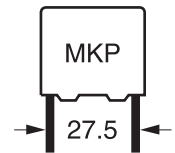
Permissible AC voltage V_{RMS} versus frequency f (for sinusoidal waveforms, $T_A \leq 85^\circ\text{C}$)

For $T_A > 85^\circ\text{C}$, please refer to derating curve. The maximum component surface temperature must be lower than 105°C and maximum temperature rise between case and free ambient shall be lower than 15°C .

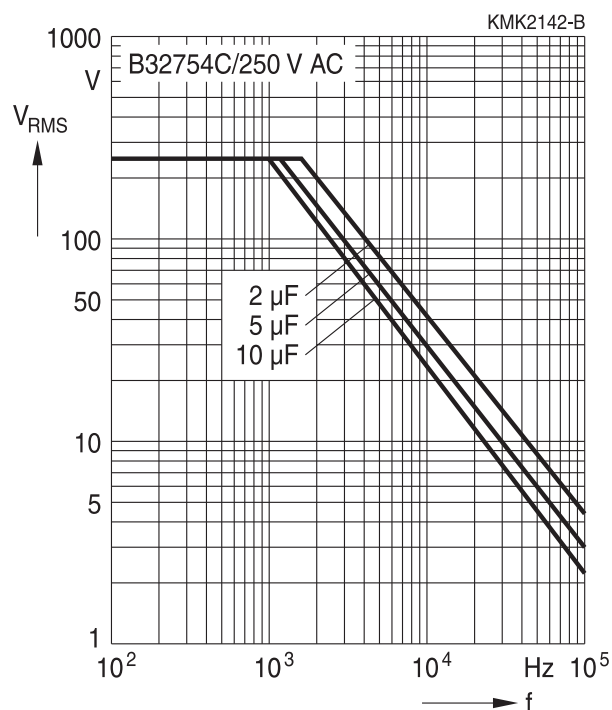
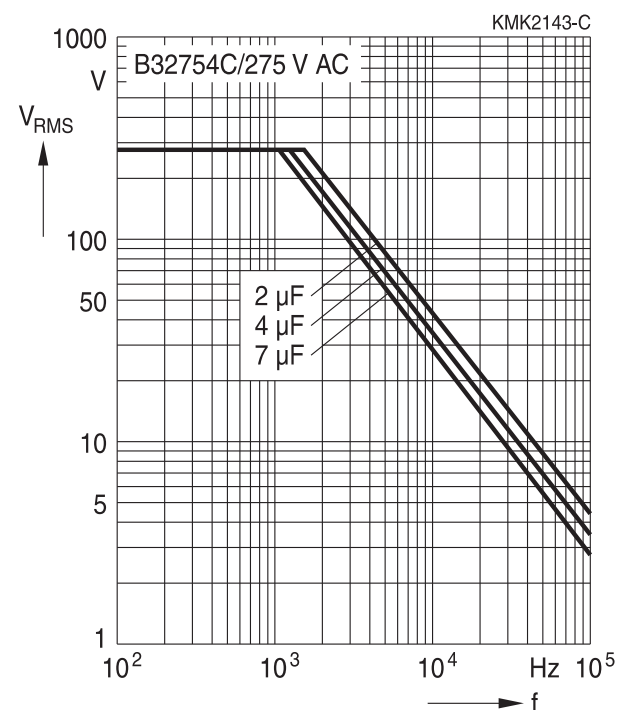
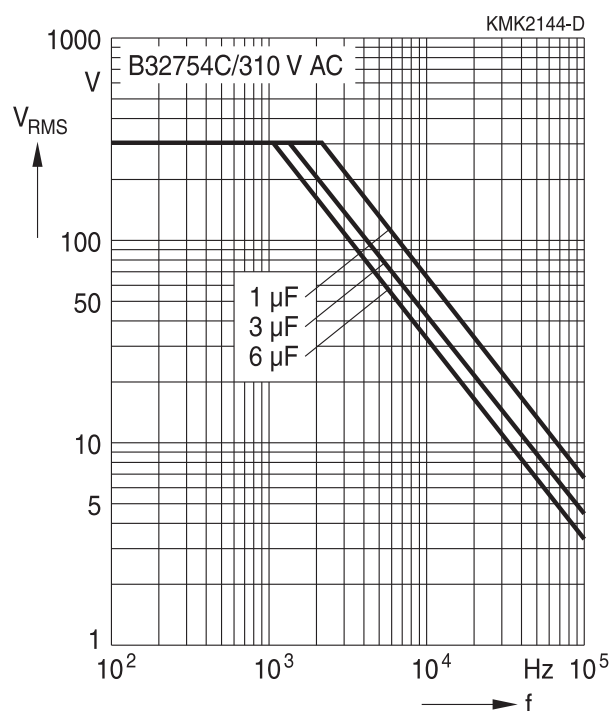
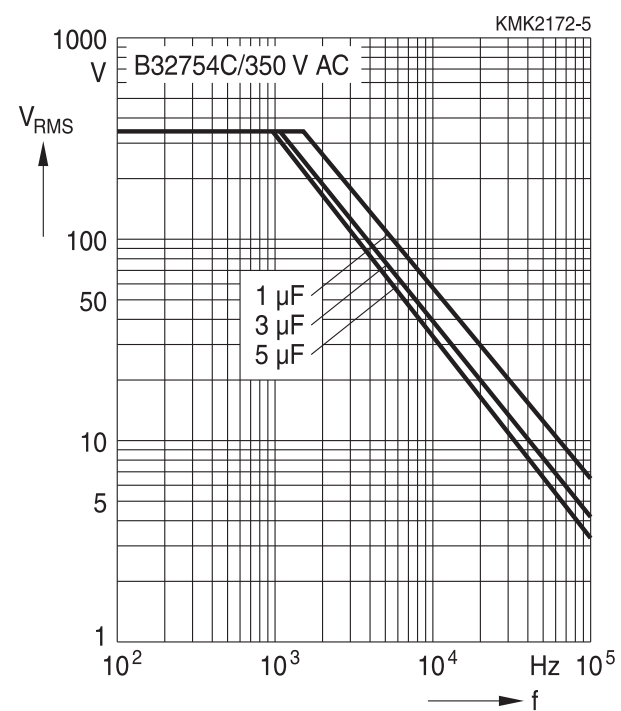
Lead spacing 27.5 mm
500 V DC/250 V AC

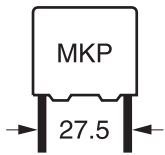
550 V DC/275 V AC

580 V DC/310 V AC

580 V DC/350 V AC



B32754

MKP AC filtering

Permissible AC voltage V_{RMS} versus frequency f (for sinusoidal waveforms, $T_A \leq 85^\circ\text{C}$)

For $T_A > 85^\circ\text{C}$, please refer to derating curve. The maximum component surface temperature must be lower than 105°C and maximum temperature rise between case and free ambient shall be lower than 15°C .

Lead spacing 27.5 mm

800 V DC/400 V AC

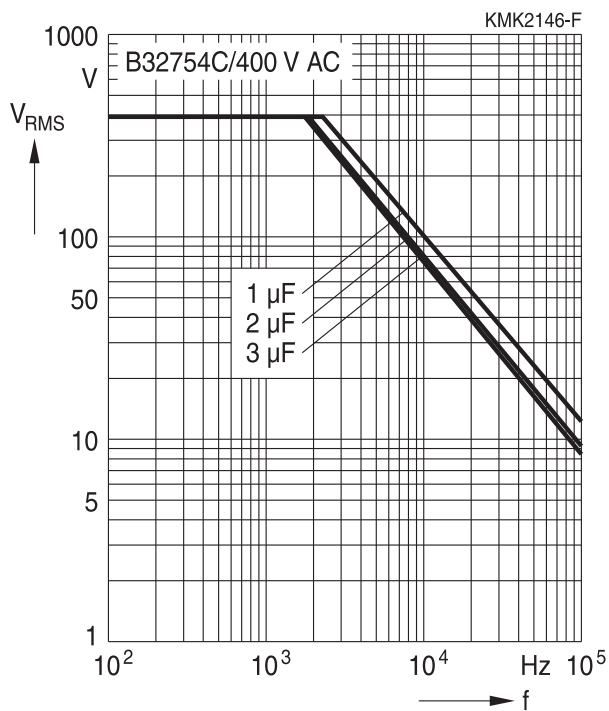

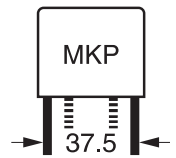
Permissible AC voltage V_{RMS} versus frequency f (for sinusoidal waveforms, $T_A \leq 85^\circ\text{C}$)

For $T_A > 85^\circ\text{C}$, please refer to derating curve. The maximum component surface temperature must be lower than 105°C and maximum temperature rise between case and free ambient shall be lower than 15°C .

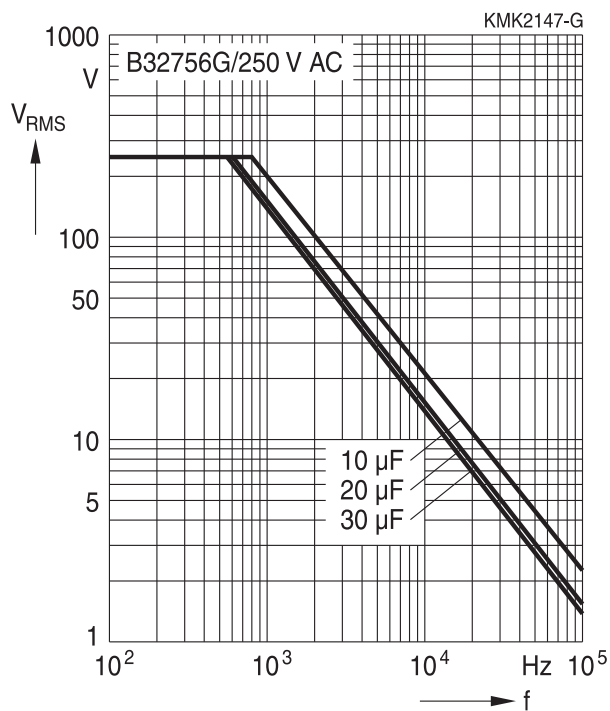
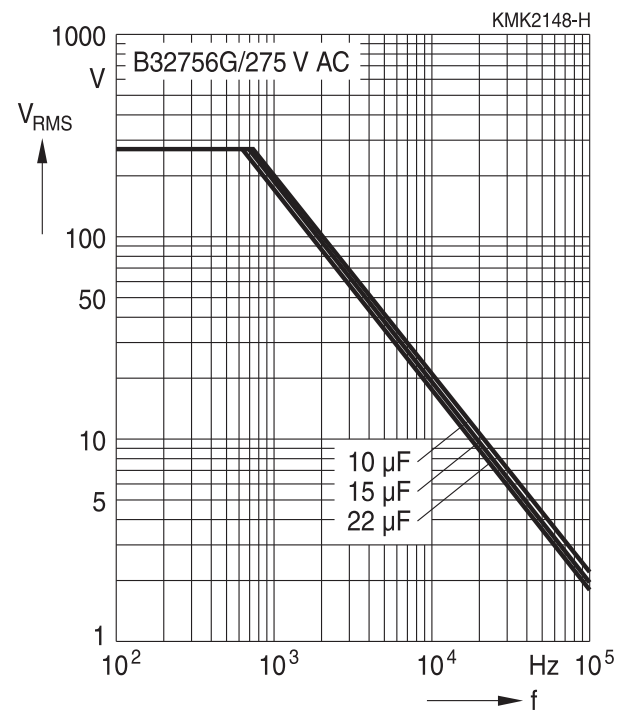
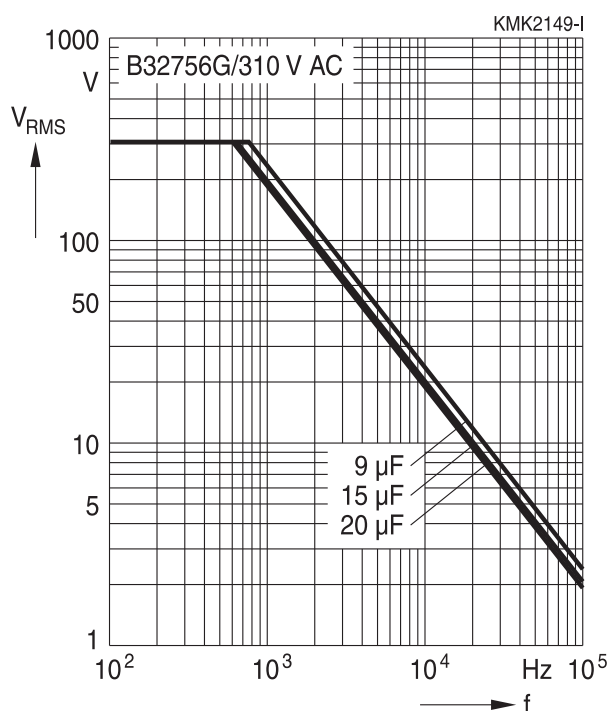
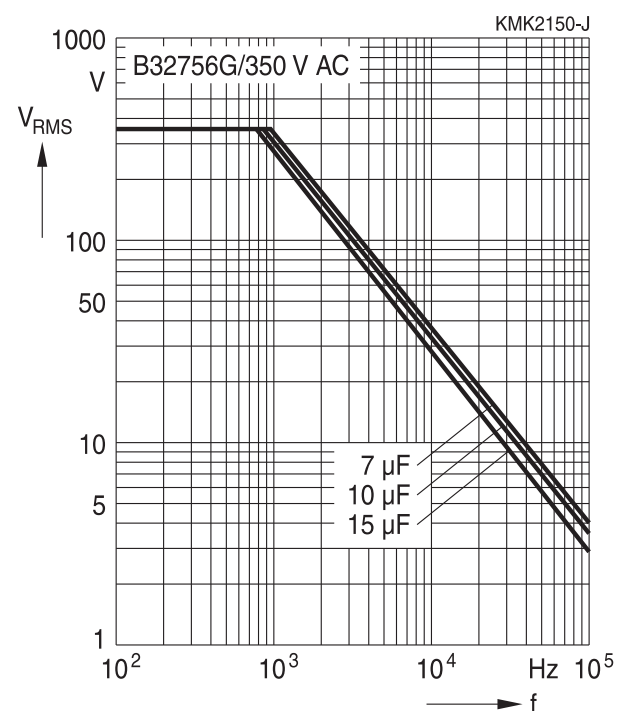
Lead spacing 37.5 mm (2 pins, 4 pins)
500 V DC/250 V AC

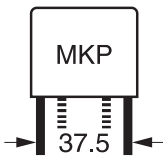
550 V DC/275 V AC

580 V DC/310 V AC

580 V DC/350 V AC



B32756

MKP AC filtering

Permissible AC voltage V_{RMS} versus frequency f (for sinusoidal waveforms, $T_A \leq 85\text{ °C}$)

For $T_A > 85\text{ °C}$, please refer to derating curve. The maximum component surface temperature must be lower than 105 °C and maximum temperature rise between case and free ambient shall be lower than 15 °C .

Lead spacing 37.5 mm (2 pins, 4 pins)

800 V DC/400 V AC

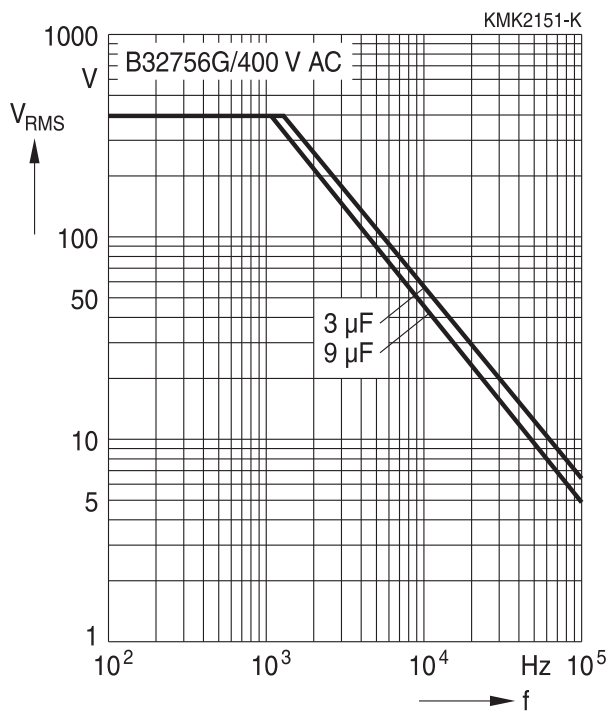

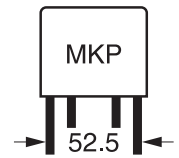

Permissible AC voltage V_{RMS} versus frequency f (for sinusoidal waveforms, $T_A \leq 85^\circ C$)

For $T_A > 85^\circ C$, please refer to derating curve. The maximum component surface temperature must be lower than $105^\circ C$ and maximum temperature rise between case and free ambient shall be lower than $15^\circ C$.

Lead spacing 52.5 mm

500 V DC/250 V AC

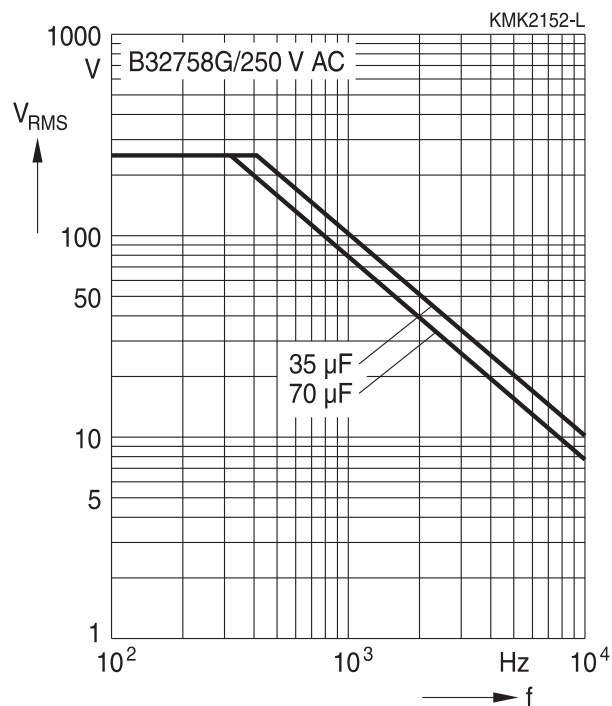

550 V DC/275 V AC

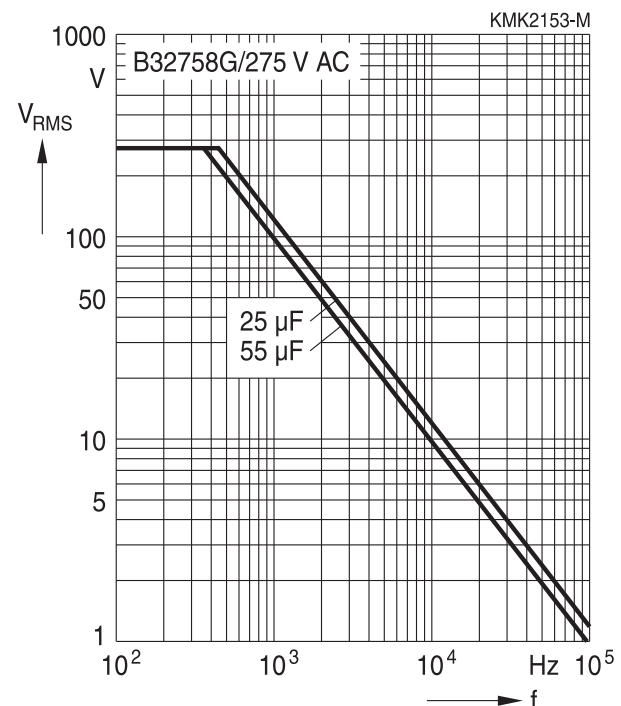

580 V DC/310 V AC

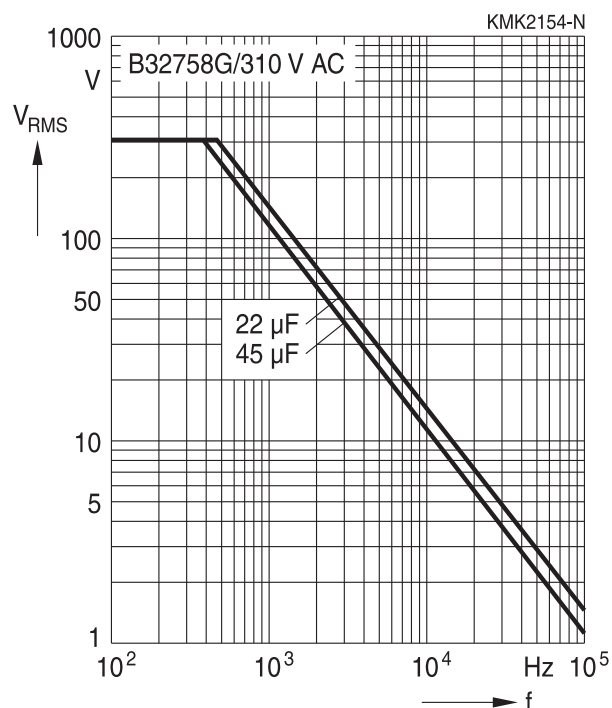

580 V DC/350 V AC

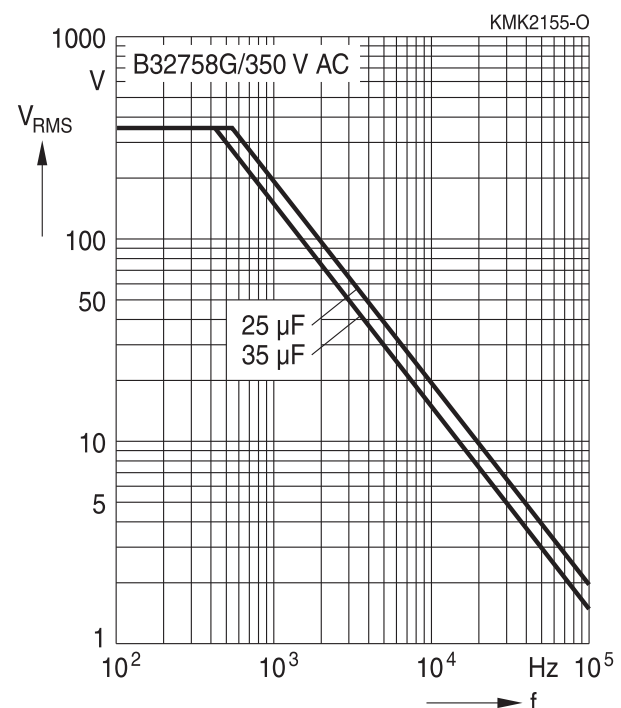

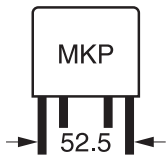

B32758

MKP AC filtering

Permissible AC voltage V_{RMS} versus frequency f (for sinusoidal waveforms, $T_A \leq 85\text{ }^\circ\text{C}$)

For $T_A > 85\text{ }^\circ\text{C}$, please refer to derating curve. The maximum component surface temperature must be lower than $105\text{ }^\circ\text{C}$ and maximum temperature rise between case and free ambient shall be lower than $15\text{ }^\circ\text{C}$.

Lead spacing 52.5 mm

800 V DC/400 V AC

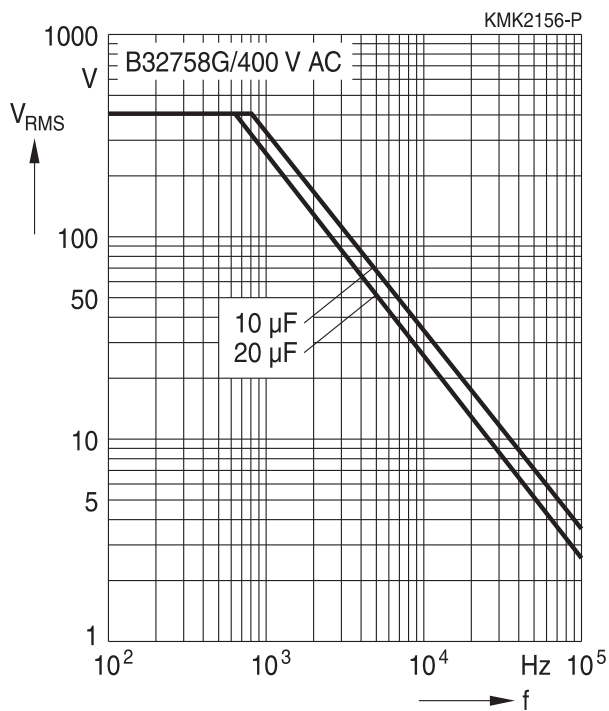

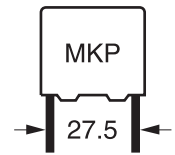

Permissible current I_{RMS} versus frequency f (for sinusoidal waveforms $T_A \leq 85^\circ C$)

For $T_A > 85^\circ C$, please use the derating curve. The maximum component surface temperature must be lower than $105^\circ C$ and maximum temperature rise between case and free ambient shall be lower than $15^\circ C$.

Lead spacing 27.5 mm

500 V DC/250 V AC

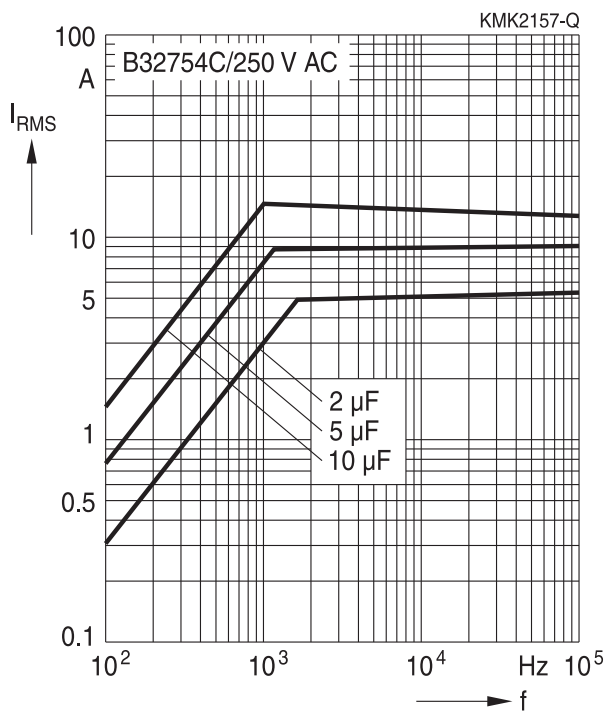

550 V DC/275 V AC

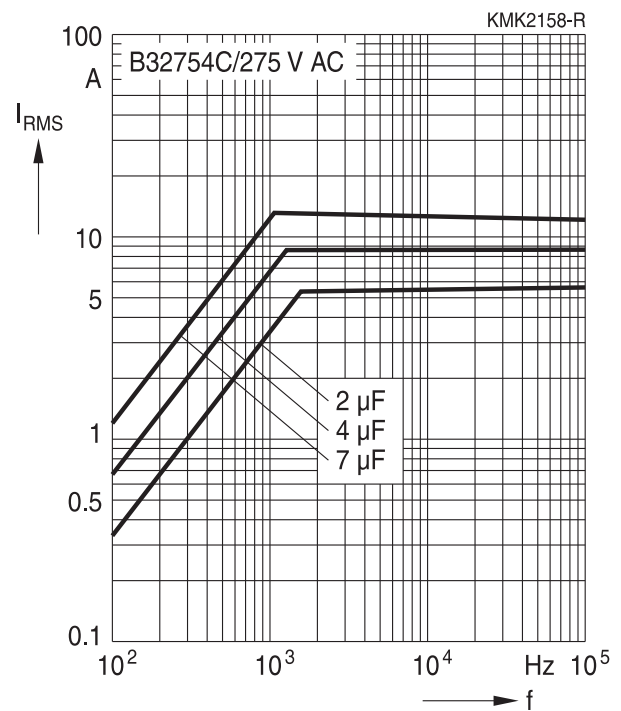

580 V DC/310 V AC

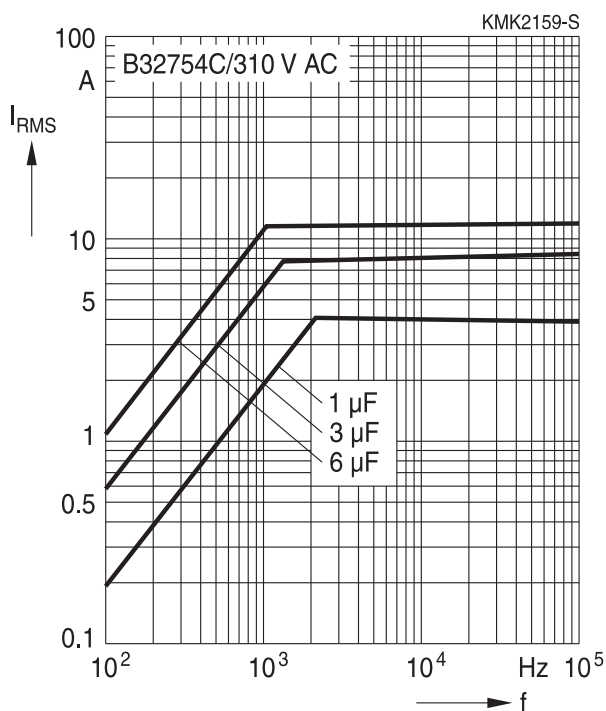

580 V DC/350 V AC

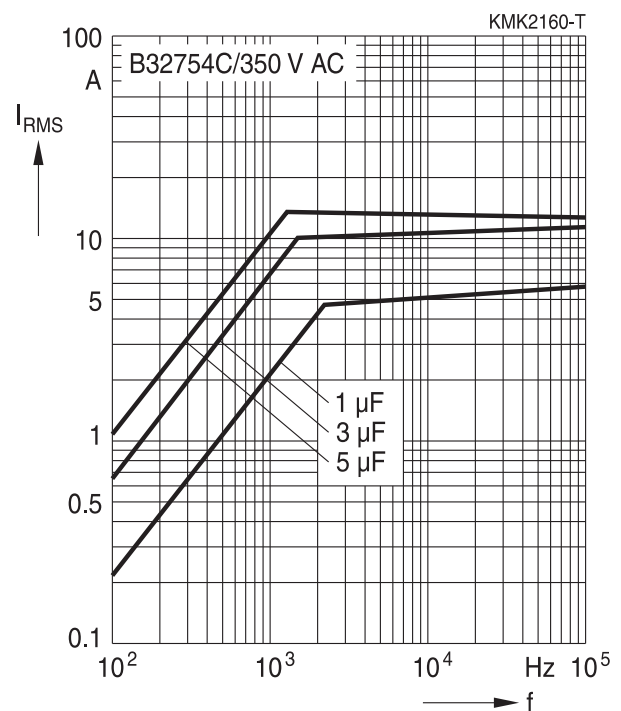

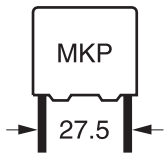

B32754

MKP AC filtering

Permissible current I_{RMS} versus frequency f (for sinusoidal waveforms $T_A \leq 85\text{ °C}$)

For $T_A > 85\text{ °C}$, please use the derating curve. The maximum component surface temperature must be lower than 105 °C and maximum temperature rise between case and free ambient shall be lower than 15 °C .

Lead spacing 27.5 mm

800 V DC/400 V AC

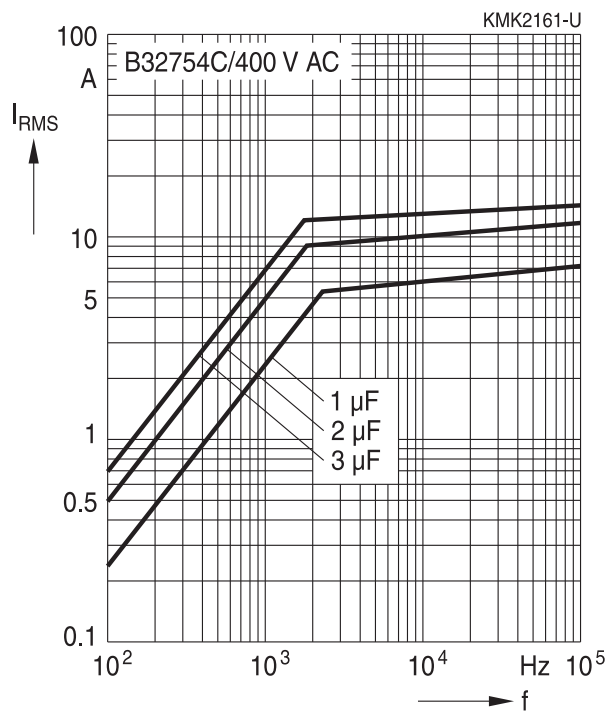

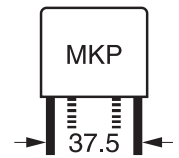
Permissible current I_{RMS} versus frequency f (for sinusoidal waveforms $T_A \leq 85^\circ\text{C}$)

For $T_A > 85^\circ\text{C}$, please use the derating curve. The maximum component surface temperature must be lower than 105°C and maximum temperature rise between case and free ambient shall be lower than 15°C .

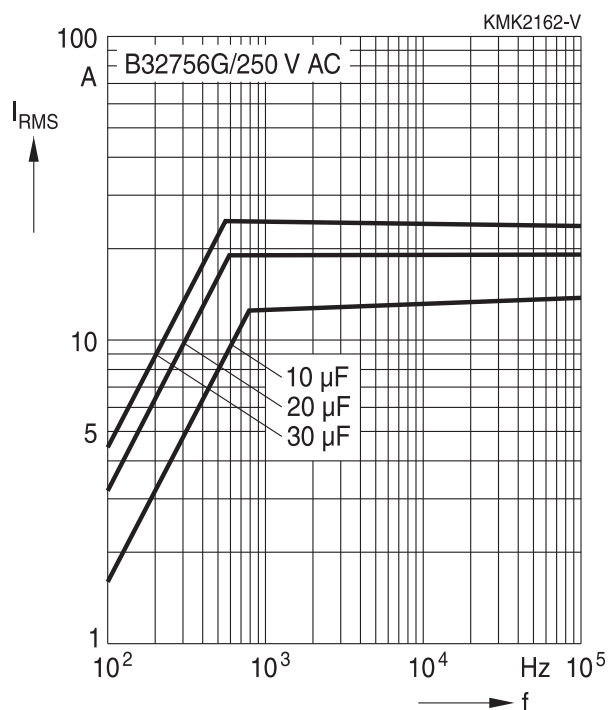
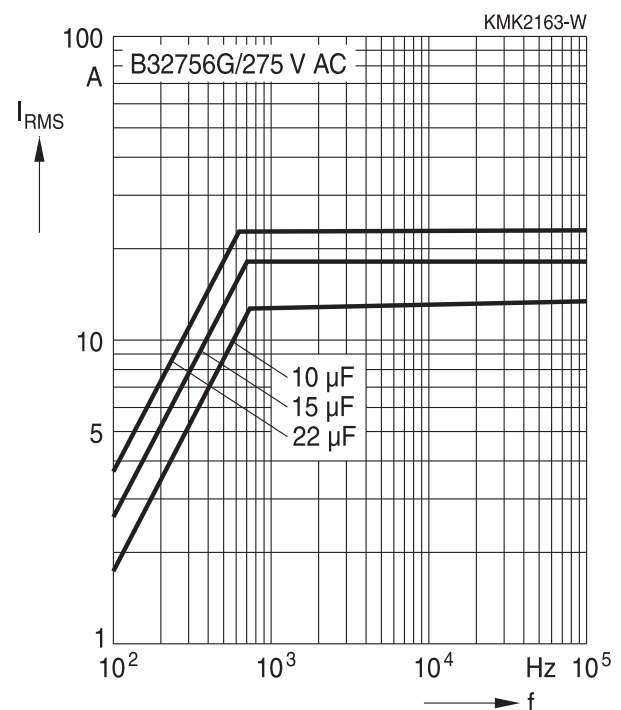
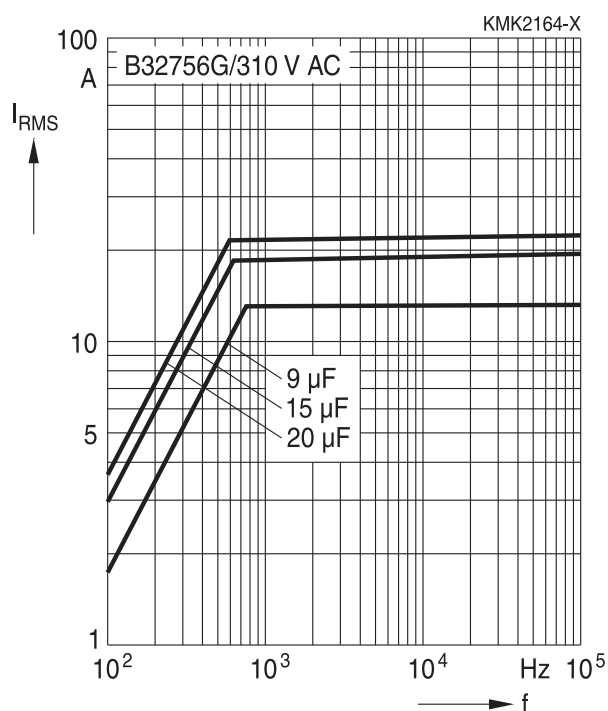
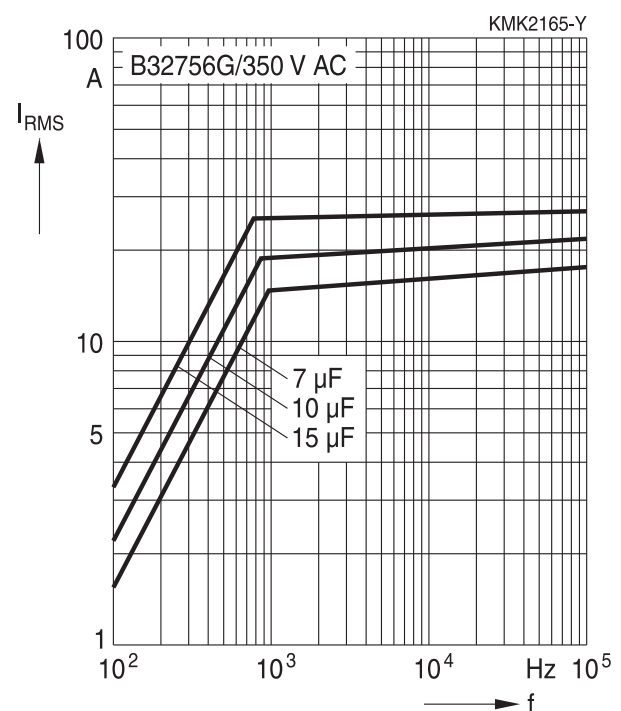
Lead spacing 37.5 mm (2 pins, 4 pins)
500 V DC/250 V AC

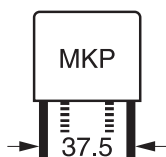
550 V DC/275 V AC

580 V DC/310 V AC

580 V DC/350 V AC



B32756

MKP AC filtering

Permissible current I_{RMS} versus frequency f (for sinusoidal waveforms $T_A \leq 85\text{ }^\circ\text{C}$)

For $T_A > 85\text{ }^\circ\text{C}$, please use the derating curve. The maximum component surface temperature must be lower than $105\text{ }^\circ\text{C}$ and maximum temperature rise between case and free ambient shall be lower than $15\text{ }^\circ\text{C}$.

Lead spacing 37.5 mm (2 pins, 4 pins)

800 V DC/400 V AC

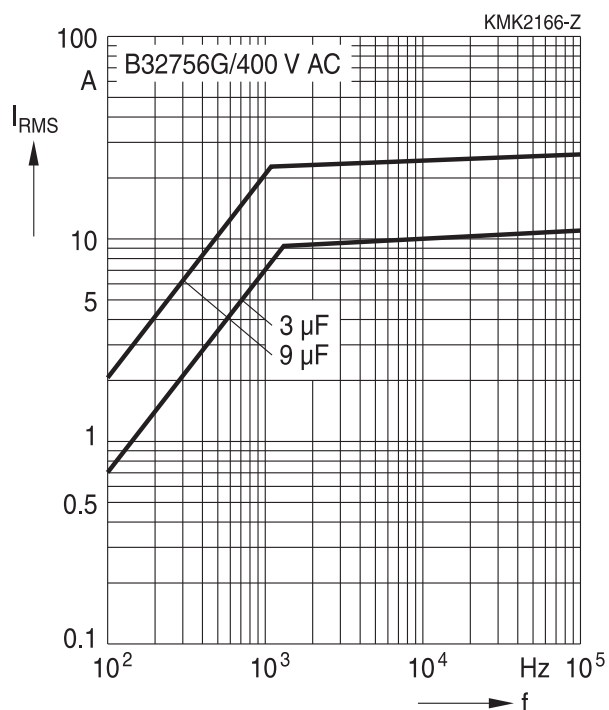

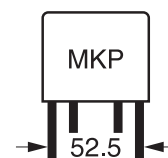
Permissible current I_{RMS} versus frequency f (for sinusoidal waveforms $T_A \leq 85^\circ\text{C}$)

For $T_A > 85^\circ\text{C}$, please use the derating curve. The maximum component surface temperature must be lower than 105°C and maximum temperature rise between case and free ambient shall be lower than 15°C .

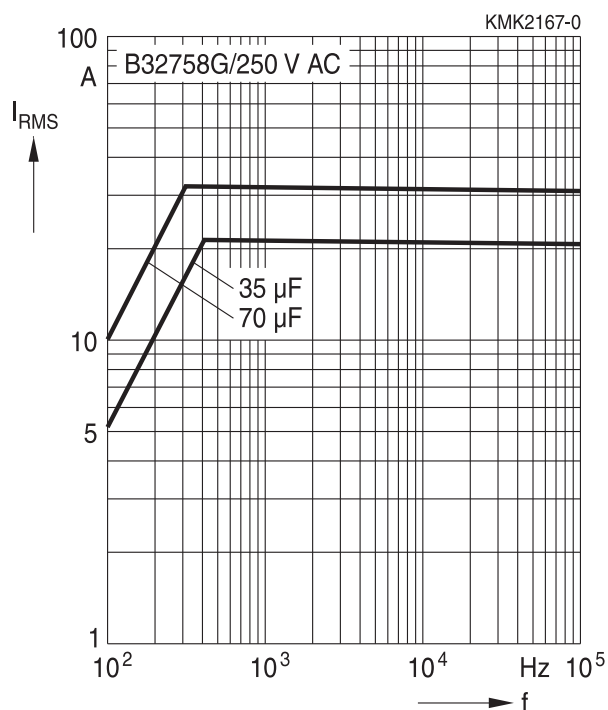
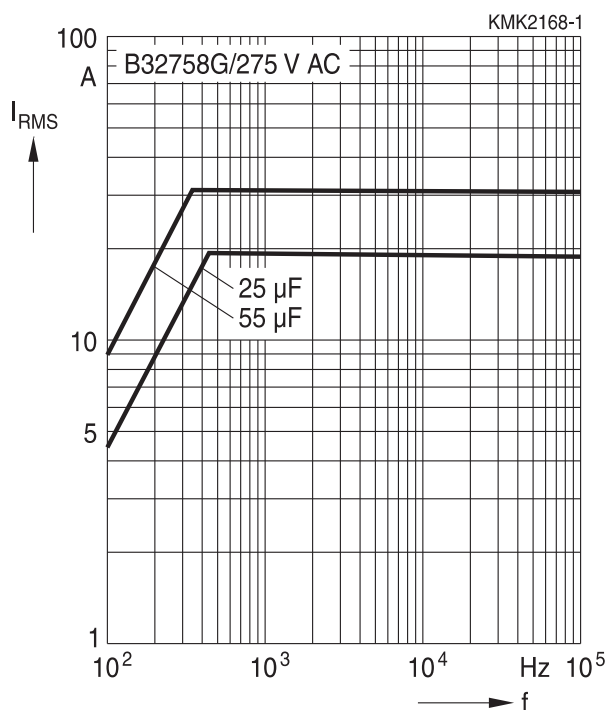
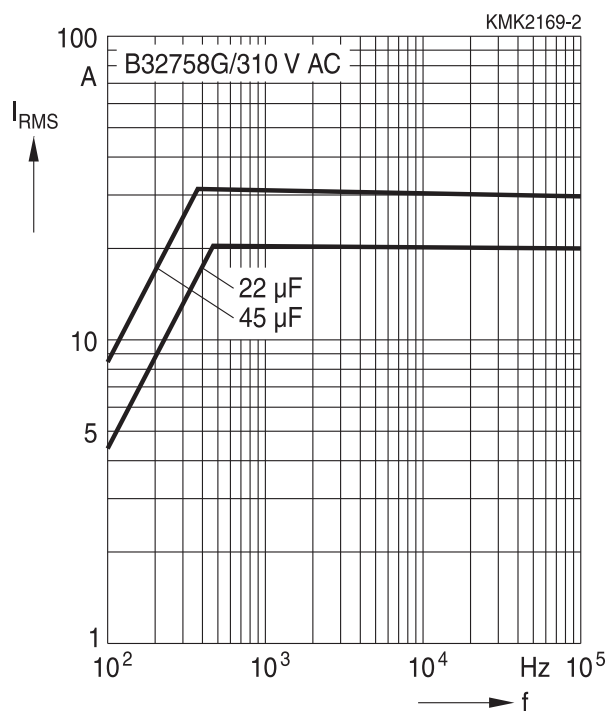
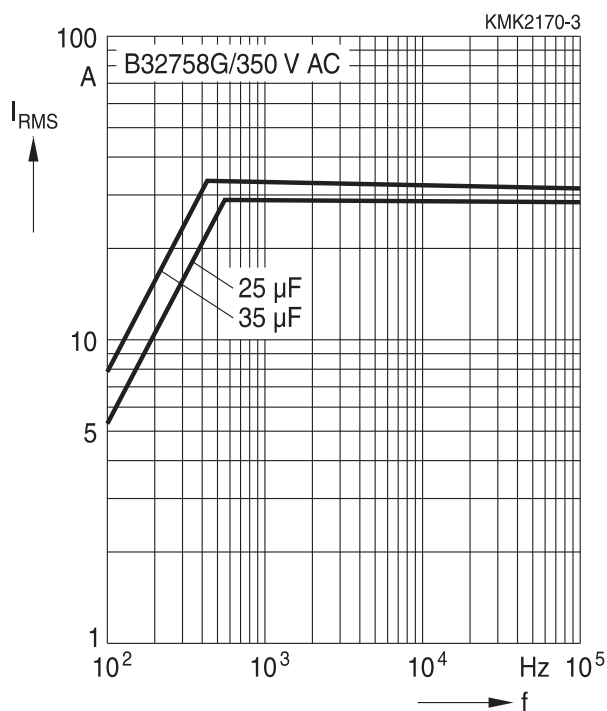
Lead spacing 52.5 mm
500 V DC/250 V AC

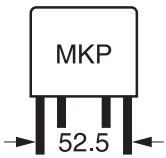
550 V DC/275 V AC

580 V DC/310 V AC

580 V DC/350 V AC



B32758

MKP AC filtering

Permissible current I_{RMS} versus frequency f (for sinusoidal waveforms $T_A \leq 85\text{ }^\circ\text{C}$)

For $T_A > 85\text{ }^\circ\text{C}$, please use the derating curve. The maximum component surface temperature must be lower than $105\text{ }^\circ\text{C}$ and maximum temperature rise between case and free ambient shall be lower than $15\text{ }^\circ\text{C}$.

Lead spacing 52.5 mm

800 V DC/400 V AC

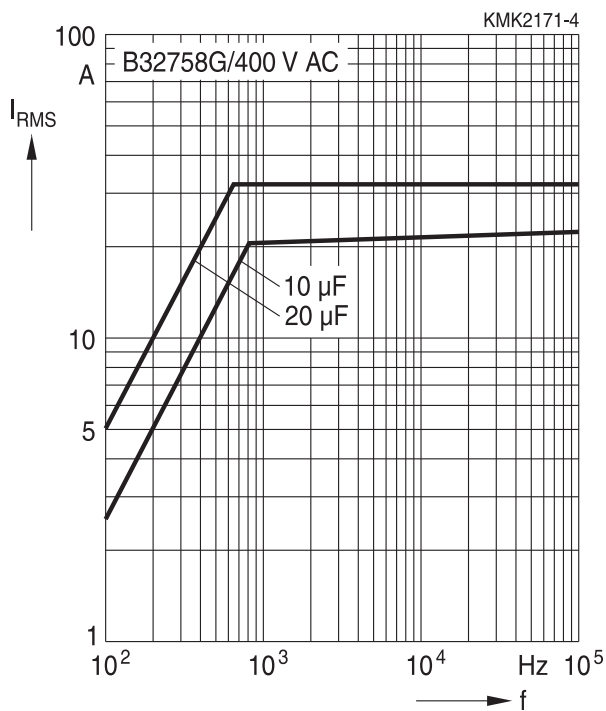

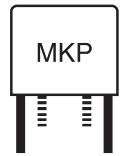

Maximum permissible continuous DC voltage versus temperature T

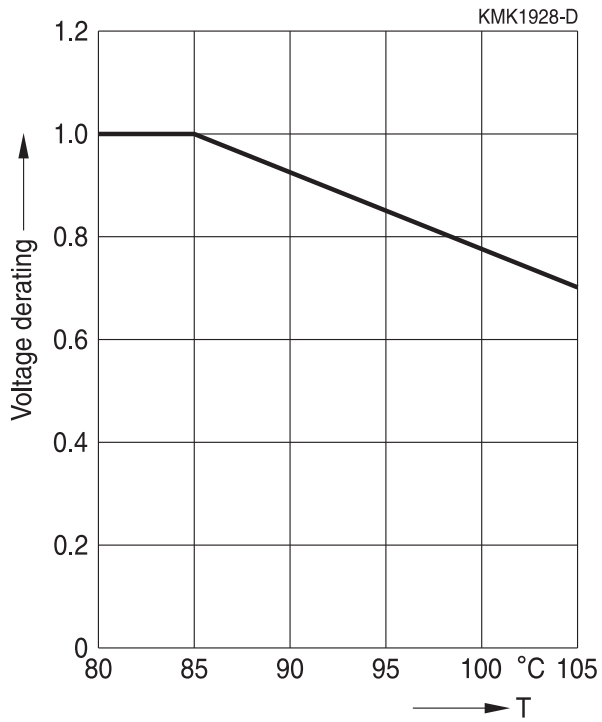

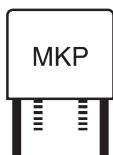

B32754 ... B32758

MKP AC filtering

Maximum AC voltage (V_{RMS}) versus temperature $T_A \leq 85\text{ °C}$

The graphs described in the previous section for the maximum AC voltage versus frequency are valid for moderate temperature: $T_A \leq 85\text{ °C}$ in MKP. For temperatures higher than these limits, we have to consider additional effects depending on the frequency and dielectric:

Low frequency ($f < f_1$)

For frequency below f_1 (the frequency is the V_{RMS} begin to derating versus frequency), a derating of the V_{RMS} versus the working temperature has to be applied, following the rules defined above.

High frequencies ($f_1 \leq f$)

For frequency below f_1 (The frequency is the V_{RMS} begin to derating versus frequency), a derating of the V_{RMS} versus the working temperature has to be applied, following the rules defined as below:

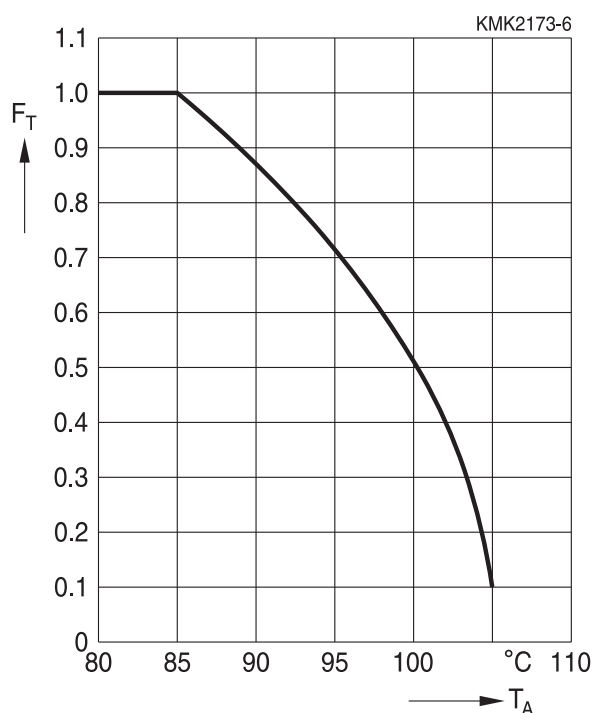

Derating factor F_T for V_{RMS} versus T_A

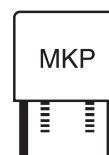

Testing and Standards

Test	Reference	Conditions of test	Performance requirements
Electrical parameters	IEC 61071:2007	Voltage between terminals: 1.5 V _R , 60 s Terminals and enclosure: 2000 V AC, 60 s Insulation resistance R _{ins} Capacitance C _R Dissipation factor tan δ	Within specified limits No visible damage No flashover
Robustness of terminations	IEC 60068-2-21:2006	Tensile strength (test U _a 1) Wire diameter Section Tensile force 0.5 <d ₁ ≤0.8 mm ≤0.5m ² 10 N 0.8 <d ₁ ≤1.25 mm ≤1.2m ² 20 N Duration: 10 s +/- 1s Bending U _b method 1 Wire diameter Section Tensile force 0.5 <d ₁ ≤0.8 mm ≤0.5m ² 10 N 0.8 <d ₁ ≤1.25 mm ≤1.2m ² 20 N 4 × 90 °C Duration: 2 s to 3 s / bend	Within specified specification
Resistance to soldering heat	IEC 60068-2-20:2008	Solder bath temperature at 260 ±5 °C, immersion for 10 seconds	ΔC/C ₀ ≤0.5% Increase of tan δ ≤0.005
Vibration	IEC 60068-2-6:2007	10 Hz to 55 Hz: Amplitude ±0.35 mm or acceleration 98 m/s ² Test duration: 10 frequency cycles, 3 axes offset from each other by 90°, 1 octave/min, Visual examination	No visible damage
Bump	IEC 60068-2-6:2007	Pulse shape: half sine Acceleration: 490 m/s ² Duration of pulse: 11 ms Visual examination	No visible damage ΔC/C ₀ ≤ 0.5% Increase of tan δ ≤ 0.005 compared to initial value

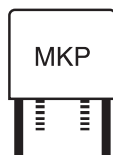

B32754 ... B32758

MKP AC filtering

Test	Reference	Conditions of test	Performance requirements
THB test (Grade III Test A, high robustness under high humidity)	IEC 60384-14: 2013/AMD1:2016	60 °C / 95% relative humidity / V_{RMS} / 1344 h	No visible damage $ \Delta C/C_0 \leq 10\%$ $\Delta \tan \delta$ (1 kHz) ≤ 0.005 $R_{ins} \geq 50\%$ specified limit
Temperature cycling	AEC-Q200:2010	T_A = lower category temperature T_R = rated temperature 1000 cycles, duration $t=30$ min	No visible damage $ \Delta C/C_0 \leq 3\%$
Surge test	IEC 61071:2007	$1.1 \cdot V_R$ or $I_{test} = 1.1 I_{max.}$ Number of discharges: 5 Time lapse: every 2 min (10 min total) within 5 min after the surge discharge test Duration: 10 s; $1.5 \cdot V_R$ at T_A	No visible damage $ \Delta C/C_0 \leq 1\%$ $\tan \delta$ (10 kHz) ≤ 1.2 initial $\tan \delta +0.0001$
Self-healing	IEC 61071:2007	$1.5 \cdot V_R$; duration 10 s Number of clearings: ≤ 5 Clearing = voltage drop of 5% Increase the voltage at 100 V/s till 5 clearings occur with a maximum of $2.5 \cdot V_R$ for a duration of 10 s	$ \Delta C/C_0 \leq 0.5\%$ $\tan \delta$ (10 kHz) ≤ 1.12 initial $\tan \delta +0.0001$
Environ- mental	IEC 61071:2007	1. Change of temperature acc. to IEC 60068-2-14, test N_b $T_{max.} = 85$ °C, $T_{min.} = -40$ °C, Transition time: 1 h, equiv. to 1 °C/min, 5 cycles 2. Damp heat steady state acc. to IEC 60068-2-78, test C_a $T = 40$ °C ± 2 °C, RH = 93% ± 3 %, Duration: 56 days 3. DC voltage between terminal, $1.5 \cdot V_R$ at ambient temperature Duration: 10 s	No puncturing or flashover Self-healing punctures permitted $ \Delta C/C_0 \leq 2\%$ Increase of $\tan \delta$ (10 kHz) ≤ 0.015
Thermal stability test under overload conditions	IEC 61071:2007	Natural cooling $T_A \pm 5$ °C $1.21 \cdot P_{max.} = (V_2/2) \cdot W_2 \cdot C \cdot \tan \delta =$ $1.21 \cdot (I_{max.}^2/W_2 \cdot C) \cdot \tan \delta_2$ with $W_2 = 2 \cdot \pi \cdot f_2$ for $I_{max.}$ (see specific reference data) $f_2 = 10$ kHz, duration 48 h Measure the temperature every 1.5 h during the last 6 h	Temperature rise < 1 °C $ \Delta C/C_0 \leq 2\%$ Increase of $\tan \delta$ (10 kHz) ≤ 1.2 initial $\tan \delta +0.015$

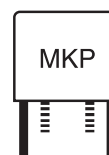

Test	Reference	Conditions of test	Performance requirements
Endurance test between terminal	IEC 61071:2007	Sequence: $1.25 \cdot V_{RMS}$ at $T_{max.} = 85 \text{ }^{\circ}\text{C}$ $1.0 \cdot V_{RMS}$ at $T_{max.} = 105 \text{ }^{\circ}\text{C}$ Duration: 500 h $1000 \times$ discharge at $1.4 \cdot I$ (max.repetitive peak current in continuous operation) $1.25 \cdot V_{RMS}$ at $T_{max.} = 85 \text{ }^{\circ}\text{C}$ $1.0 \cdot V_{RMS}$ at $T_{max.} = 105 \text{ }^{\circ}\text{C}$ Duration: 500 h	$ \Delta C/C_0 \leq 3\%$ Increase of $\tan \delta$ ≤ 0.015 compared to initial value

Mounting guidelines

1 Soldering

1.1 Solderability of leads

The solderability of terminal leads is tested to IEC 60068-2-20, test Ta, method 1.

Before a solderability test is carried out, terminals are subjected to accelerated ageing (to IEC 60068-2-2, test Ba: 4 h exposure to dry heat at 155 °C). Since the ageing temperature is far higher than the upper category temperature of the capacitors, the terminal wires should be cut off from the capacitor before the ageing procedure to prevent the solderability being impaired by the products of any capacitor decomposition that might occur.

Solder bath temperature	$235 \pm 5 \text{ }^{\circ}\text{C}$
Soldering time	$2.0 \pm 0.5 \text{ s}$
Immersion depth	$2.0 +0/-0.5 \text{ mm}$ from capacitor body or seating plane
Evaluation criteria:	
Visual inspection	Wetting of wire surface by new solder $\geq 90\%$, free-flowing solder

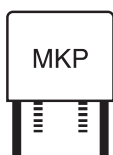

B32754 ... B32758

MKP AC filtering

1.2 Resistance to soldering heat

Resistance to soldering heat is tested to IEC 60068-2-20, test Tb, method 1.

Conditions:

Series	Solder bath temperature	Soldering time
MKT boxed (except $2.5 \times 6.5 \times 7.2$ mm) coated uncoated (lead spacing >10 mm)	260 ± 5 °C	10 ± 1 s
MFP MKP (lead spacing >7.5 mm)		
MKT boxed (case $2.5 \times 6.5 \times 7.2$ mm)		5 ± 1 s
MKP (lead spacing ≤ 7.5 mm)		<4 s
MKT uncoated (lead spacing ≤ 10 mm) insulated (B32559)		recommended soldering profile for MKT uncoated (lead spacing ≤ 10 mm) and insulated (B32559)

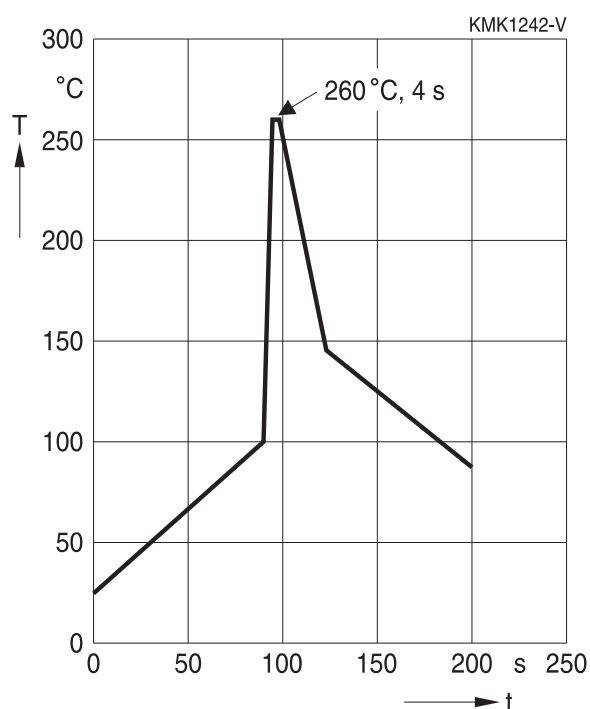

Immersion depth	$2.0 +0/-0.5$ mm from capacitor body or seating plane
Shield	Heat-absorbing board, (1.5 ± 0.5) mm thick, between capacitor body and liquid solder
Evaluation criteria:	
Visual inspection	No visible damage
$\Delta C/C_0$	2% for MKT/MKP/MFP 5% for EMI suppression capacitors
$\tan \delta$	As specified in sectional specification

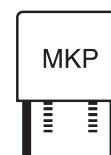

1.3 General notes on soldering

Permissible heat exposure loads on film capacitors are primarily characterized by the upper category temperature T_{max} . Long exposure to temperatures above this type-related temperature limit can lead to changes in the plastic dielectric and thus change irreversibly a capacitor's electrical characteristics. For short exposures (as in practical soldering processes) the heat load (and thus the possible effects on a capacitor) will also depend on other factors like:

- Pre-heating temperature and time
- Forced cooling immediately after soldering
- Terminal characteristics:
diameter, length, thermal resistance, special configurations (e.g. crimping)
- Height of capacitor above solder bath
- Shadowing by neighboring components
- Additional heating due to heat dissipation by neighboring components
- Use of solder-resist coatings

The overheating associated with some of these factors can usually be reduced by suitable countermeasures. For example, if a pre-heating step cannot be avoided, an additional or reinforced cooling process may possibly have to be included.

Recommendations

As a reference, the recommended wave soldering profile for our film capacitors is as follows:

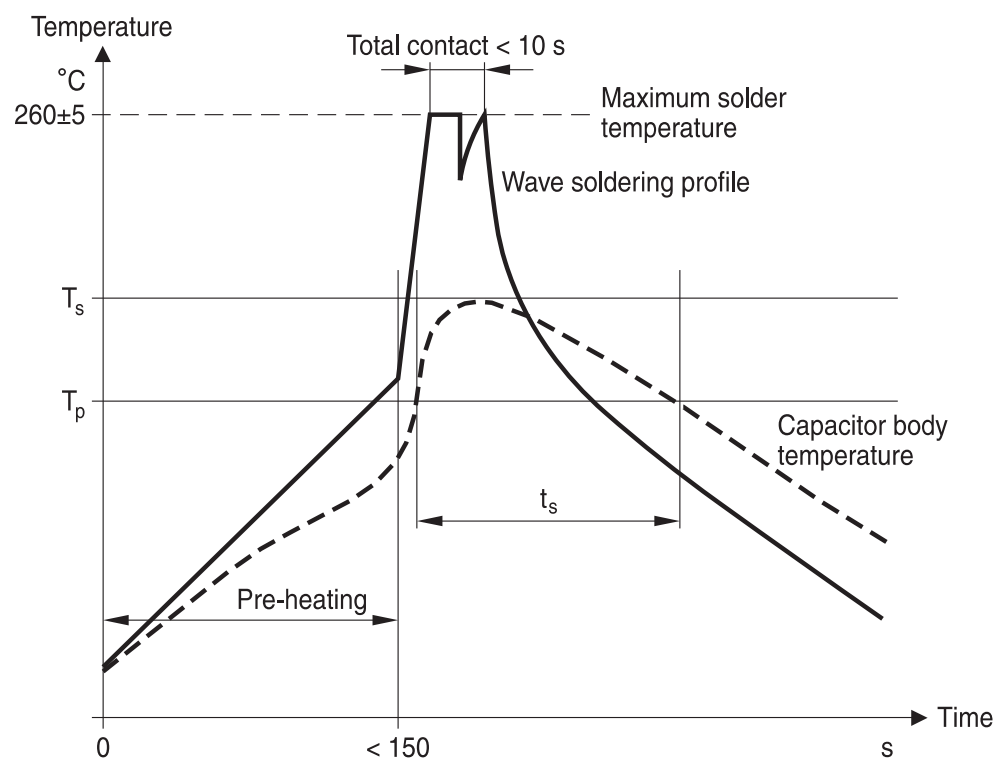

T_s : Capacitor body maximum temperature at wave soldering

T_p : Capacitor body maximum temperature at pre-heating

KMK1745-A-E

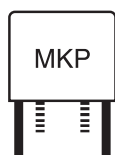

B32754 ... B32758

MKP AC filtering

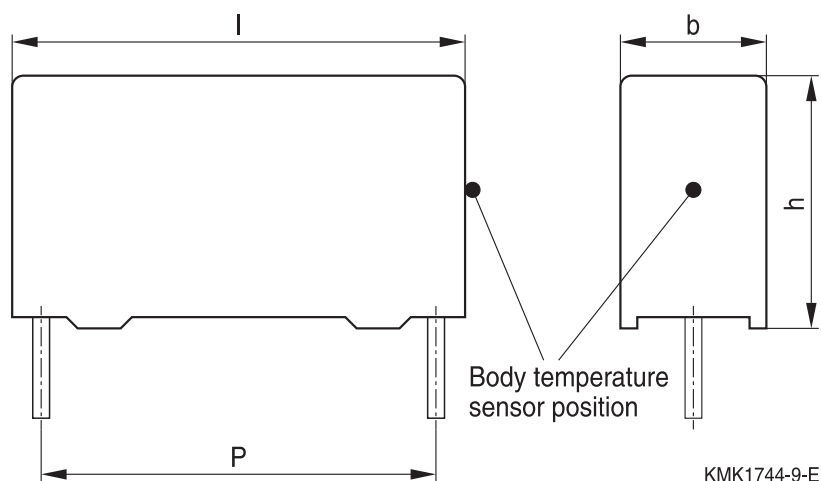

Body temperature should follow the description below:

- MKP capacitor
 - During pre-heating: $T_p \leq 110 \text{ }^\circ\text{C}$
 - During soldering: $T_s \leq 120 \text{ }^\circ\text{C}$, $t_s \leq 45 \text{ s}$
- MKT capacitor
 - During pre-heating: $T_p \leq 125 \text{ }^\circ\text{C}$
 - During soldering: $T_s \leq 160 \text{ }^\circ\text{C}$, $t_s \leq 45 \text{ s}$

When SMD components are used together with leaded ones, the film capacitors should not pass into the SMD adhesive curing oven. The leaded components should be assembled after the SMD curing step.

Leaded film capacitors are not suitable for reflow soldering.

In order to ensure proper conditions for manual or selective soldering, the body temperature of the capacitor (T_s) must be $\leq 120 \text{ }^\circ\text{C}$.

One recommended condition for manual soldering is that the tip of the soldering iron should be $< 360 \text{ }^\circ\text{C}$ and the soldering contact time should be no longer than 3 seconds.

For uncoated MKT capacitors with lead spacings $\leq 10 \text{ mm}$ (B32560/B32561) the following measures are recommended:

- pre-heating to not more than $110 \text{ }^\circ\text{C}$ in the preheater phase
- rapid cooling after soldering

Please refer to our Film Capacitors Data Book in case more details are needed.

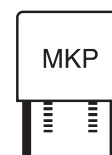

Cautions and warnings

- Do not exceed the upper category temperature (UCT).
- Do not apply any mechanical stress to the capacitor terminals.
- Avoid any compressive, tensile or flexural stress.
- Do not move the capacitor after it has been soldered to the PC board.
- Do not pick up the PC board by the soldered capacitor.
- Do not place the capacitor on a PC board whose PTH hole spacing differs from the specified lead spacing.
- Do not exceed the specified time or temperature limits during soldering.
- Avoid external energy inputs, such as fire or electricity.
- Avoid overload of the capacitors.
- Consult us if application is with severe temperature and humidity condition.
- There are no serviceable or repairable parts inside the capacitor. Opening the capacitor or any attempts to open or repair the capacitor will void the warranty and liability of TDK Electronics.
- Please note that the standards referred to in this publication may have been revised in the meantime.

The table below summarizes the safety instructions that must always be observed. A detailed description can be found in the relevant sections of the chapters "General technical information" and "Mounting guidelines".

Topic	Safety information	Reference chapter "General technical information"
Storage conditions	Make sure that capacitors are stored within the specified range of time, temperature and humidity conditions.	4.5 "Storage conditions"
Flammability	Avoid external energy, such as fire or electricity (passive flammability), avoid overload of the capacitors (active flammability) and consider the flammability of materials.	5.3 "Flammability"
Resistance to vibration	Do not exceed the tested ability to withstand vibration. The capacitors are tested to IEC 60068-2-6:2007. TDK Electronics offers film capacitors specially designed for operation under more severe vibration regimes such as those found in automotive applications. Consult our catalog "Film Capacitors for Automotive Electronics".	5.2 "Resistance to vibration"

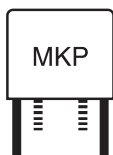

B32754 ... B32758

MKP AC filtering

Topic	Safety information	Reference chapter "Mounting guidelines"
Soldering	Do not exceed the specified time or temperature limits during soldering.	1 "Soldering"
Cleaning	Use only suitable solvents for cleaning capacitors.	2 "Cleaning"
Embedding of capacitors in finished assemblies	When embedding finished circuit assemblies in plastic resins, chemical and thermal influences must be taken into account. Caution: Consult us first, if you also wish to embed other uncoated component types!	3 "Embedding of capacitors in finished assemblies"

Display of ordering codes for TDK Electronics products

The ordering code for one and the same product can be represented differently in data sheets, data books, other publications, on the company website, or in order-related documents such as shipping notes, order confirmations and product labels. The varying representations of the ordering codes are due to different processes employed and do not affect the specifications of the respective products.

Detailed information can be found on the Internet under www.tdk-electronics.tdk.com/orderingcodes.

Correlation of data sheet values and modelling tool outputs

Data sheet values and results of design tools may deviate as they have not been derived in the same context.

While data sheets show individual parameter statements without considering a possible dependency to other parameters. Tools model a complete given scenario as input and processed inside the tool.

Furthermore as we constantly strive to improve our models, the results of tools can change over time and be a non-binding indication only.

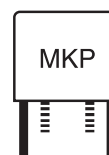

Symbols and terms

Symbol	English	German
α	Heat transfer coefficient	Wärmeübergangszahl
α_C	Temperature coefficient of capacitance	Temperaturkoeffizient der Kapazität
A	Capacitor surface area	Kondensatoroberfläche
β_C	Humidity coefficient of capacitance	Feuchtekoeffizient der Kapazität
C	Capacitance	Kapazität
C_R	Rated capacitance	Nennkapazität
ΔC	Absolute capacitance change	Absolute Kapazitätsänderung
$\Delta C/C$	Relative capacitance change (relative deviation of actual value)	Relative Kapazitätsänderung (relative Abweichung vom Ist-Wert)
$\Delta C/C_R$	Capacitance tolerance (relative deviation from rated capacitance)	Kapazitätstoleranz (relative Abweichung vom Nennwert)
dt	Time differential	Differentielle Zeit
Δt	Time interval	Zeitintervall
ΔT	Absolute temperature change (self-heating)	Absolute Temperaturänderung (Selbsterwärmung)
$\Delta \tan \delta$	Absolute change of dissipation factor	Absolute Änderung des Verlustfaktors
ΔV	Absolute voltage change	Absolute Spannungsänderung
dV/dt	Time differential of voltage function (rate of voltage rise)	Differentielle Spannungsänderung (Spannungsflankensteilheit)
$\Delta V/\Delta t$	Voltage change per time interval	Spannungsänderung pro Zeitintervall
E	Activation energy for diffusion	Aktivierungsenergie zur Diffusion
ESL	Self-inductance	Eigeninduktivität
ESR	Equivalent series resistance	Ersatz-Serienwiderstand
f	Frequency	Frequenz
f_1	Frequency limit for reducing permissible AC voltage due to thermal limits	Grenzfrequenz für thermisch bedingte Reduzierung der zulässigen Wechselspannung
f_2	Frequency limit for reducing permissible AC voltage due to current limit	Grenzfrequenz für strombedingte Reduzierung der zulässigen Wechselspannung
f_r	Resonant frequency	Resonanzfrequenz
F_D	Thermal acceleration factor for diffusion	Therm. Beschleunigungsfaktor zur Diffusion
F_T	Derating factor	Deratingfaktor
i	Current (peak)	Stromspitze
I_C	Category current (max. continuous current)	Kategoriestrom (max. Dauerstrom)

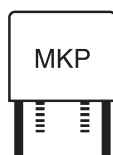

B32754 ... B32758

MKP AC filtering

Symbol	English	German
I_{RMS}	(Sinusoidal) alternating current, root-mean-square value	(Sinusförmiger) Wechselstrom
i_z	Capacitance drift	Inkonstanz der Kapazität
k_0	Pulse characteristic	Impuls Kennwert
L_S	Series inductance	Serieninduktivität
λ	Failure rate	Ausfallrate
λ_0	Constant failure rate during useful service life	Konstante Ausfallrate in der Nutzungsphase
λ_{test}	Failure rate, determined by tests	Experimentell ermittelte Ausfallrate
P_{diss}	Dissipated power	Abgegebene Verlustleistung
P_{gen}	Generated power	Erzeugte Verlustleistung
Q	Heat energy	Wärmeenergie
ρ	Density of water vapor in air	Dichte von Wasserdampf in Luft
R	Universal molar constant for gases	Allg. Molarkonstante für Gas
R	Ohmic resistance of discharge circuit	Ohmscher Widerstand des Entladekreises
R_i	Internal resistance	Innenwiderstand
R_{ins}	Insulation resistance	Isolationswiderstand
R_P	Parallel resistance	Parallelwiderstand
R_S	Series resistance	Serienwiderstand
S	severity (humidity test)	Schärfegrad (Feuchtetest)
t	Time	Zeit
T	Temperature	Temperatur
τ	Time constant	Zeitkonstante
$\tan \delta$	Dissipation factor	Verlustfaktor
$\tan \delta_D$	Dielectric component of dissipation factor	Dielektrischer Anteil des Verlustfaktors
$\tan \delta_P$	Parallel component of dissipation factor	Parallelanteil des Verlustfaktors
$\tan \delta_S$	Series component of dissipation factor	Serienanteil des Verlustfaktors
T_A	Temperature of the air surrounding the component	Temperatur der Luft, die das Bauteil umgibt
T_{max}	Upper category temperature	Obere Kategorietemperatur
T_{min}	Lower category temperature	Untere Kategorietemperatur
t_{OL}	Operating life at operating temperature and voltage	Betriebszeit bei Betriebstemperatur und -spannung
T_{op}	Operating temperature, $T_A + \Delta T$	Betriebstemperatur, $T_A + \Delta T$
T_R	Rated temperature	Nenntemperatur
T_{ref}	Reference temperature	Referenztemperatur
t_{SL}	Reference service life	Referenz-Lebensdauer

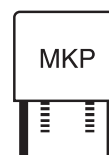

Symbol	English	German
V_{AC}	AC voltage	Wechselspannung
V_C	Category voltage	Kategoriespannung
$V_{C,RMS}$	Category AC voltage	(Sinusförmige) Kategorie-Wechselspannung
V_{CD}	Corona-discharge onset voltage	Teilentlade-Einsatzspannung
V_{ch}	Charging voltage	Ladespannung
V_{DC}	DC voltage	Gleichspannung
V_{FB}	Fly-back capacitor voltage	Spannung (Flyback)
V_i	Input voltage	Eingangsspannung
V_o	Output voltage	Ausgangsspannung
V_{op}	Operating voltage	Betriebsspannung
V_p	Peak pulse voltage	Impuls-Spitzenspannung
V_{pp}	Peak-to-peak voltage Impedance	Spannungshub
V_R	Rated voltage	Nennspannung
\hat{V}_R	Amplitude of rated AC voltage	Amplitude der Nenn-Wechselspannung
V_{RMS}	(Sinusoidal) alternating voltage, root-mean-square value	(Sinusförmige) Wechselspannung
V_{SC}	S-correction voltage	Spannung bei Anwendung "S-correction"
V_{sn}	Snubber capacitor voltage	Spannung bei Anwendung "Beschaltung"
Z	Impedance	Scheinwiderstand
e	Lead spacing	Rastermaß

Important notes

The following applies to all products named in this publication:

1. Some parts of this publication contain **statements about the suitability of our products for certain areas of application**. These statements are based on our knowledge of typical requirements that are often placed on our products in the areas of application concerned. We nevertheless expressly point out **that such statements cannot be regarded as binding statements about the suitability of our products for a particular customer application**. As a rule, we are either unfamiliar with individual customer applications or less familiar with them than the customers themselves. For these reasons, it is always ultimately incumbent on the customer to check and decide whether a product with the properties described in the product specification is suitable for use in a particular customer application.
2. We also point out that **in individual cases, a malfunction of electronic components or failure before the end of their usual service life cannot be completely ruled out in the current state of the art, even if they are operated as specified**. In customer applications requiring a very high level of operational safety and especially in customer applications in which the malfunction or failure of an electronic component could endanger human life or health (e.g. in accident prevention or lifesaving systems), it must therefore be ensured by means of suitable design of the customer application or other action taken by the customer (e.g. installation of protective circuitry or redundancy) that no injury or damage is sustained by third parties in the event of malfunction or failure of an electronic component.
3. **The warnings, cautions and product-specific notes must be observed.**
4. In order to satisfy certain technical requirements, **some of the products described in this publication may contain substances subject to restrictions in certain jurisdictions (e.g. because they are classed as hazardous)**. Useful information on this will be found in our Material Data Sheets on the Internet (www.tdk-electronics.tdk.com/material). Should you have any more detailed questions, please contact our sales offices.
5. We constantly strive to improve our products. Consequently, **the products described in this publication may change from time to time**. The same is true of the corresponding product specifications. Please check therefore to what extent product descriptions and specifications contained in this publication are still applicable before or when you place an order. We also **reserve the right to discontinue production and delivery of products**. Consequently, we cannot guarantee that all products named in this publication will always be available. The aforementioned does not apply in the case of individual agreements deviating from the foregoing for customer-specific products.
6. Unless otherwise agreed in individual contracts, **all orders are subject to our General Terms and Conditions of Supply**.



Important notes

7. **Our manufacturing sites serving the automotive business apply the IATF 16949 standard.** The IATF certifications confirm our compliance with requirements regarding the quality management system in the automotive industry. Referring to customer requirements and customer specific requirements (“CSR”) TDK always has and will continue to have the policy of respecting individual agreements. Even if IATF 16949 may appear to support the acceptance of unilateral requirements, we hereby like to emphasize that **only requirements mutually agreed upon can and will be implemented in our Quality Management System.** For clarification purposes we like to point out that obligations from IATF 16949 shall only become legally binding if individually agreed upon.
8. The trade names EPCOS, CarXield, CeraCharge, CeraDiode, CeraLink, CeraPad, CeraPlas, CSMP, CTVS, DeltaCap, DigiSiMic, ExoCore, FilterCap, FormFit, LeaXield, MiniBlue, MiniCell, MKD, MKK, ModCap, MotorCap, PCC, PhaseCap, PhaseCube, PhaseMod, PhiCap, PowerHap, PQSine, PQvar, SIFERRIT, SIFI, SIKOREL, SilverCap, SIMDAD, SiMic, SIMID, SineFormer, SIOV, ThermoFuse, WindCap, XieldCap are **trademarks registered or pending** in Europe and in other countries. Further information will be found on the Internet at www.tdk-electronics.tdk.com/trademarks.

Release 2020-06

Looking for pricing, stock, or lifecycle information?

Click below to explore more details on WIN SOURCE:

-  [View B32756G2106J000 on WIN SOURCE](#)
-  [EPCOS \(TDK\) Information](#)

Optimize Your Supply Chain with WIN SOURCE Solutions

-  Global Sourcing Solution
-  Obsolete Management
-  Cost Control Management
-  Shortage Management
-  Alternative Solution
-  Excess Inventory Management