

AUTOMOTIVE & INDUSTRIAL GRADE 32.768kHz SMD CRYSTAL

ABS07AIG

Request Samples



Check Inventory



3.2 x 1.5 x 0.9 mm

RoHS/RoHS II Compliant

MSL Level = N/A



Features

- AEC-Q200 Qualified
- Automotive Grade 1: -40°C to +125°C
- TS16949 Production Line Certified
- PPAP Available Upon Request
- Hermetically Seam-sealed Ceramic Package
- RoHS/RoHS II Compliant and Pb free

Applications

- Infotainment Systems
- Keyless Entry & Startup
- GPS & Navigation
- Comfort control
- ADAS (Advanced Driver Assistance Systems)
- Vehicle to Vehicle Communication
- LiDAR (Light Detection and Ranging)
- In-vehicle Networking
- Powertrain & Drive Control
- Power Control & Conversion

Key Electrical Specifications

Parameters	Min.	Typ.	Max.	Units	Notes
Frequency	32.768			kHz	
Operation Mode	Flexural Mode (Tuning Fork)				
Operating Temperature	-40		+125	°C	Option "blank"; See options
Storage Temperature	-55		+125	°C	
Frequency Tolerance @ +25°C	-20		+20	ppm	Option "blank"; See options
Temperature Coefficient	-0.040	-0.036		ppm/T ²	
Turn-over Temperature	+20	+25	+30	°C	
Equivalent series resistance (ESR)			70	kΩ	Over -40°C to +85°C
			70		Over -40°C to +105°C
			80		Over -40°C to +125°C
Shunt capacitance (C0)		<1.4		pF	
Motional capacitance (C1)		3.0 ~ 6.0		fF	
Load capacitance (CL)	12.5			pF	Option "blank"; See options
Drive Level		0.1	0.5	μW	
Q value	10000	30000			
Aging	-3		+3	ppm	@25°C± 3°C First year
Insulation Resistance	500			MΩ	@ 100 Vdc

AUTOMOTIVE & INDUSTRIAL GRADE 32.768kHz SMD CRYSTAL

ABS07AIG

Request Samples



Check Inventory



3.2 x 1.5 x 0.9 mm
RoHS/RoHS II Compliant
 MSL Level = N/A



Options and Part Identification (left blank if standard)

ABS07AIG – 32.768kHz- - - -

Load Capacitance
Blank: 12.5pF
9: 9pF
7: 7pF
6: 6pF
5: 5pF

Operating Temp. Range
Blank: -40 ~ +125°C
D: -40 ~ +85°C
J: -40°C to +105°C

Freq. Tolerance
Blank: ±20ppm
1: ±10ppm
4: ±30ppm

Packaging
Blank: Bulk
T: 3k pcs / reel
T9: 9k pcs / reel

AUTOMOTIVE & INDUSTRIAL GRADE 32.768kHz SMD CRYSTAL

ABS07AIG

Request Samples



Check Inventory



3.2 x 1.5 x 0.9 mm
RoHS/RoHS II Compliant
MSL Level = N/A



Mechanical Dimensions

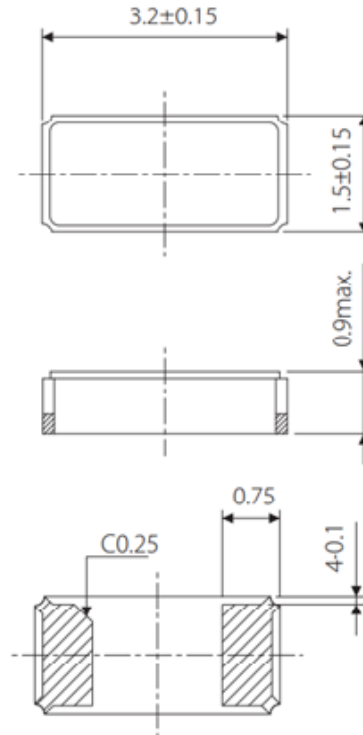

Recommended Land Pattern

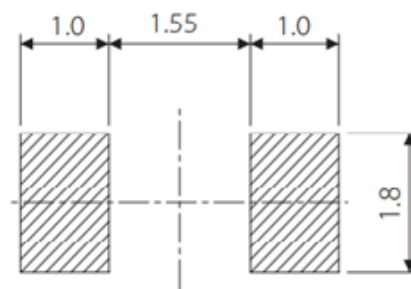

Dimensions: mm

Sealing Method = Seam Sealing



5101 Hidden Creek Ln Spicewood TX 78669
Phone: 512-371-6159 | Fax: 512-351-8858
For terms and conditions of sales, please visit:
www.abracon.com

REVISED: 05-18-23

Revision #: J

ABRACON IS
ISO9001-2015
CERTIFIED

AUTOMOTIVE & INDUSTRIAL GRADE 32.768kHz SMD CRYSTAL

ABS07AIG

Request Samples



Check Inventory



3.2 x 1.5 x 0.9 mm
RoHS/RoHS II Compliant
MSL Level = N/A



Reflow Profile [JEDEC J-STD-020]

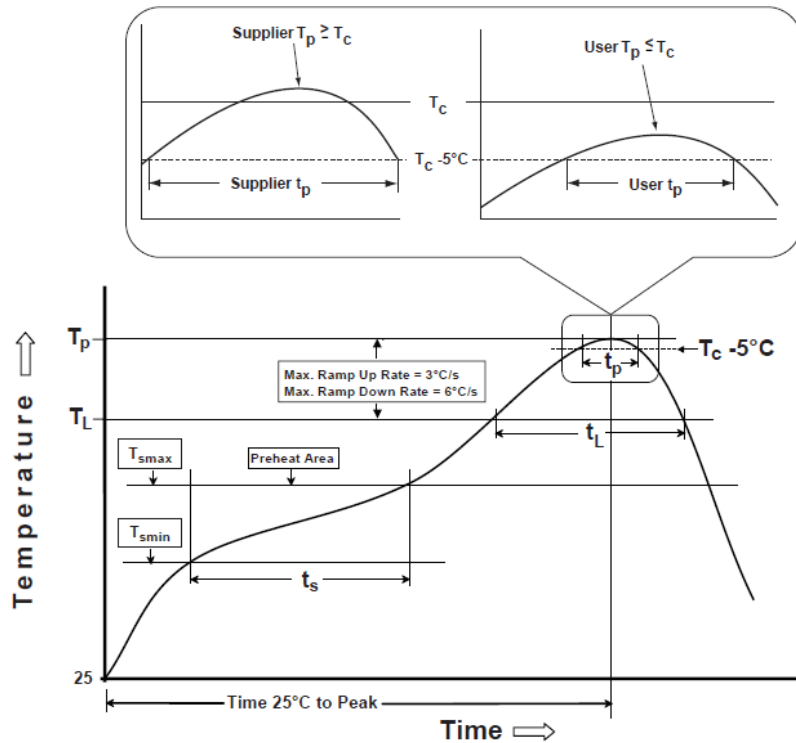

Table 1

SnPb Eutectic Process Classification Temperatures (T_c)

Package Thickness	Volume mm ³ <350	Volume mm ³ ≥350
<2.5 mm	235 °C	220 °C
≥2.5 mm	220 °C	220 °C

Table 2

Pb-Free Process Classification Temperatures (T_c)

Package Thickness	Volume mm ³ <350	Volume mm ³ 350-2000	Volume mm ³ >2000
<1.6 mm	260 °C	260 °C	260 °C
1.6 mm - 2.5 mm	260 °C	250 °C	245 °C
>2.5 mm	250 °C	245 °C	245 °C

Profile Feature	Sn-Pb Eutectic Assembly	Pb-Free Assembly
Preheat / soak		
Temperature minimum (T_{smin})	100°C	150°C
Temperature maximum (T_{smax})	150°C	200°C
Time (T_{smin} to T_{smax}) (t_s)	60 - 120 sec.	60 - 120 sec.
Average ramp-up rate (T_{smax} to T_p)	3°C/sec. max	3°C/sec. max
Liquidous temperature (T_L)	183°C	217°C
Time at liquidous (t_L)	60 - 150 sec.	60 - 150 sec.
Peak package body temperature (T_p)*	see Table 1	see Table 2
Time (t_p)** within 5°C of the specified classification temperature (T_c)	20 sec.	30 sec.
Ramp-down rate (T_p to T_{smax})	6°C/sec. max	6°C/sec. max
Time 25°C to peak temperature	6 min. max	8 min. max
Reflow cycles	2 max	2 max

*Tolerance for peak profile temperature (T_p) is defined as a supplier minimum and a user maximum.

**Tolerance for time at peak profile temperature (t_p) is defined as supplier minimum and a user maximum.



5101 Hidden Creek Ln Spicewood TX 78669
Phone: 512-371-6159 | Fax: 512-351-8858
For terms and conditions of sales, please visit:
www.abracon.com

REVISED: 05-18-23

Revision #: J

ABRACON IS
ISO9001-2015
CERTIFIED

AUTOMOTIVE & INDUSTRIAL GRADE 32.768kHz SMD CRYSTAL

ABS07AIG

Request Samples



Check Inventory



3.2 x 1.5 x 0.9 mm
RoHS/RoHS II Compliant
MSL Level = N/A



Packaging

T=Tape and reel (3,000pcs/reel)

T9=Tape and reel (9,000pcs/reel)

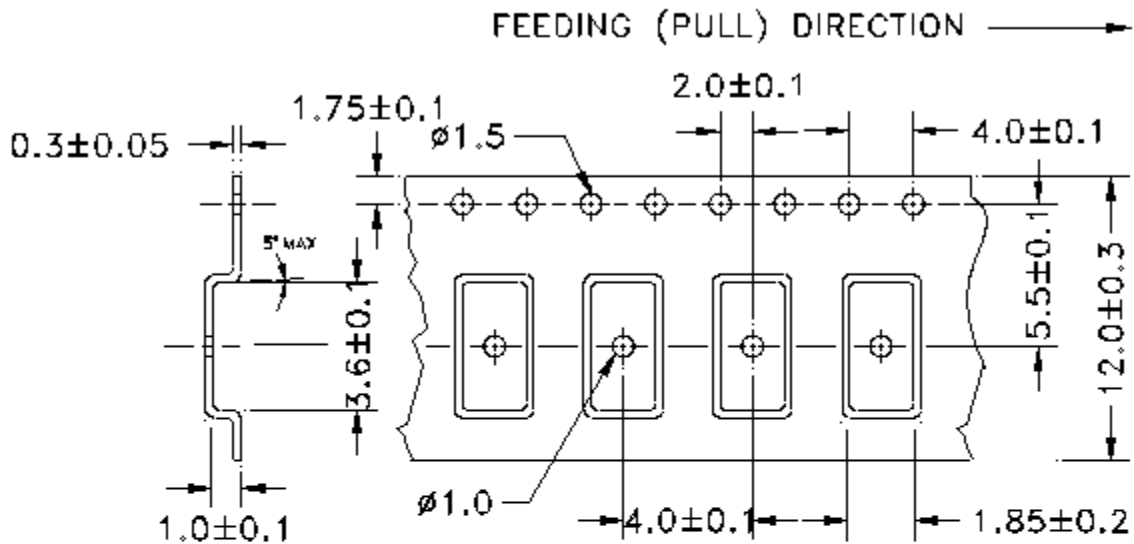

Reel=3,000pcs

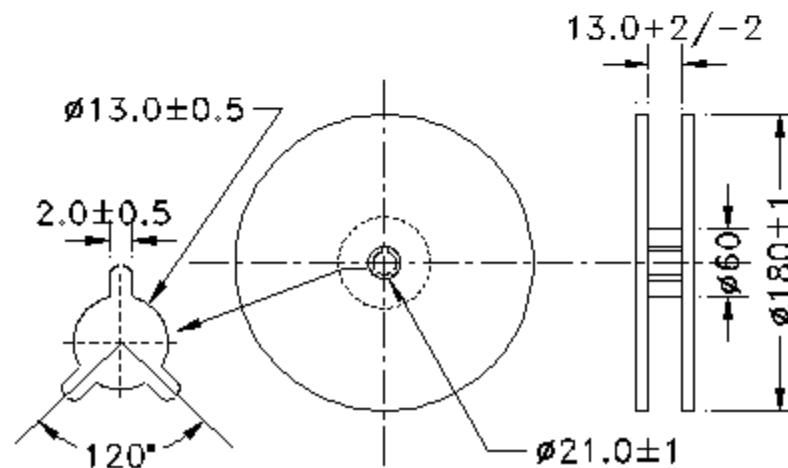

Dimensions: mm

AUTOMOTIVE & INDUSTRIAL GRADE 32.768kHz SMD CRYSTAL

ABS07AIG

Request Samples



Check Inventory



3.2 x 1.5 x 0.9 mm
RoHS/RoHS II Compliant
MSL Level = N/A



Reel=9,000pcs

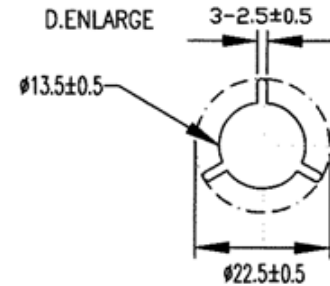
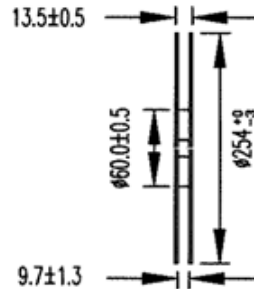
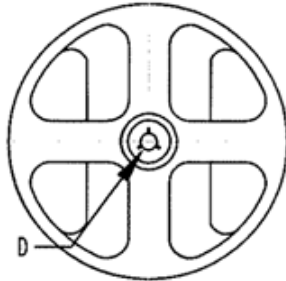

Dimensions: mm

ATTENTION: Abracon LLC's products are COTS – Commercial-Off-The-Shelf products; suitable for Commercial, Industrial and, where designated, Automotive Applications. Abracon's products are not specifically designed for Military, Aviation, Aerospace, Life-dependent Medical applications or any application requiring high reliability where component failure could result in loss of life and/or property. For applications requiring high reliability and/or presenting an extreme operating environment, written consent and authorization from Abracon LLC is required. Please contact Abracon LLC for more information.



5101 Hidden Creek Ln Spicewood TX 78669
Phone: 512-371-6159 | Fax: 512-351-8858
For terms and conditions of sales, please visit:
www.abracon.com

REVISED: 05-18-23

Revision #: J

ABRACON IS
ISO9001-2015
CERTIFIED

Looking for pricing, stock, or lifecycle information?

Click below to explore more details on WIN SOURCE:

- ⊖ [View ABS07AIG-32.768KHZ-7-T on WIN SOURCE](#)
- ⊖ [Abracon LLC Information](#)

Optimize Your Supply Chain with WIN SOURCE Solutions

- ✓ Global Sourcing Solution
- ✓ Obsolete Management
- ✓ Cost Control Management
- ✓ Shortage Management
- ✓ Alternative Solution
- ✓ Excess Inventory Management