

DATA SHEET

SURFACE-MOUNT CERAMIC MULTILAYER CAPACITORS

Low-Inductance

X5R / X7R

6.3 V TO 50 V

10 nF to 1 μ F

RoHS compliant & Halogen Free



SCOPE

This specification describes LW revised low ESL chips multilayer ceramic capacitors with lead-free terminations

APPLICATIONS

High speed IC packages
Processor package decoupling
AC noise reduction in multi-chip modules.

FEATURES

Supplied in tape on reel
Nickel-barrier end termination
RoHS compliant
Halogen Free compliant

ORDERING INFORMATION - GLOBAL PART NUMBER, PHYCOMP CTC

All part numbers are identified by the series, size, tolerance, TC material, packing style, voltage, process code, termination and capacitance value.

YAGEO BRAND ordering code

GLOBAL PART NUMBER (PREFERRED)

CL XXXX X X XXX X **BB** XXX
(1) (2) (3) (4) (5) (6)

(1) SIZE – INCH BASED (METRIC)

0204(0510)
0306(0816)
0508(1220)
0612(1632)

(2) TOLERANCE

K = ±10%
M = ±20%

(3) PACKING STYLE

R = Paper/PE taping reel; Reel 7 inch
K = Blister taping reel; Reel 7 inch
P = Paper/PE taping reel; Reel 13 inch
F = Blister taping reel; Reel 13 inch

(4) TC MATERIAL

X5R / X7R

(5) RATED VOLTAGE

5 = 6.3 V
6 = 10 V
7 = 16 V
8 = 25 V
9 = 50 V

(6) CAPACITANCE VALUE

2 significant digits+number of zeros
The 3rd digit signifies the multiplying factor, and letter R is decimal point
Example: 121 = 12 × 10¹ = 120 pF

CONSTRUCTION

The capacitor consists of a rectangular block of ceramic dielectric in which a number of interleaved metal electrodes are contained. This structure gives rise to a high capacitance per unit volume.

The inner electrodes are connected to the two end terminations and finally covered with a layer of plated tin (NiSn). The terminations are lead-free. A cross section of the structure is shown in Fig.1.

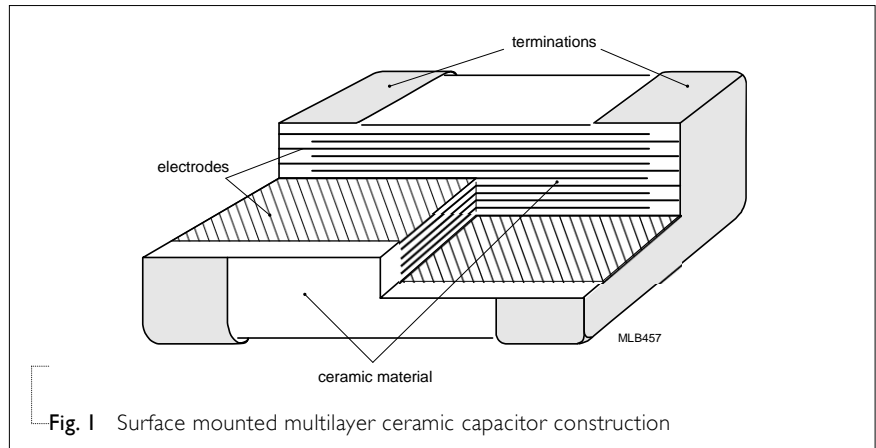

Fig. 1 Surface mounted multilayer ceramic capacitor construction

DIMENSION

Table I For outlines see fig. 2

TYPE	L ₁ (mm)	W (mm)	T (mm)	L ₂ / L ₃ (mm)		L ₄ (mm)
				min.	max.	
0204	0.5 ±0.1	1.0 ±0.1	0.3 ±0.05	0.1	0.3	0.1
0306	0.8 ±0.15	1.6 ±0.2	0.5 ±0.1	0.1	0.3	0.2
0508	1.25 ±0.2	2.0 ±0.2	0.85 ±0.1	0.13	0.46	0.38
0612	1.6 ±0.2	3.2 ±0.2	0.85 ±0.1	0.13	0.46	0.50
0612*	1.6 ±0.2	3.2 ±0.2	1.15 ±0.1	0.13	0.46	0.50

0612*: 1uF/16V, 470nF~1uF/25V, 120nF~470nF/50V

OUTLINES

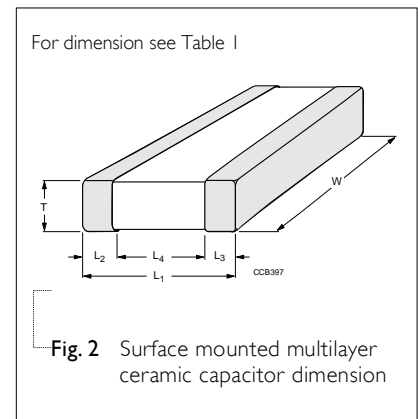

Fig. 2 Surface mounted multilayer ceramic capacitor dimension

CAPACITANCE RANGE & THICKNESS FOR X5R

Table 2 Sizes from 0204

CAP.	0204 6.3 V / 10V
10 nF	0.3 ±0.05
15 nF	0.3 ±0.05
22 nF	0.3 ±0.05
33 nF	0.3 ±0.05
47 nF	0.3 ±0.05
68 nF	0.3 ±0.05
100 nF	0.3 ±0.05
150 nF	
220 nF	
330 nF	
470 nF	
680 nF	
1 uF	

NOTE

1. Values in shaded cells indicate thickness class in mm

CAPACITANCE RANGE & THICKNESS FOR X7R

Table 3 Sizes from 0306 to 0508

CAP.	0306	0508	16 V	25 V
	6.3 V / 10V	6.3V/10V		
10 nF	0.5 ±0.1	0.85 ±0.1	0.85 ±0.1	0.85 ±0.1
15 nF	0.5 ±0.1	0.85 ±0.1	0.85 ±0.1	0.85 ±0.1
22 nF	0.5 ±0.1	0.85 ±0.1	0.85 ±0.1	0.85 ±0.1
33 nF	0.5 ±0.1	0.85 ±0.1	0.85 ±0.1	0.85 ±0.1
47 nF	0.5 ±0.1	0.85 ±0.1	0.85 ±0.1	0.85 ±0.1
68 nF	0.5 ±0.1	0.85 ±0.1	0.85 ±0.1	0.85 ±0.1
100 nF	0.5 ±0.1	0.85 ±0.1	0.85 ±0.1	0.85 ±0.1
150 nF	0.5 ±0.1	0.85 ±0.1	0.85 ±0.1	
220 nF	0.5 ±0.1	0.85 ±0.1	0.85 ±0.1	
330 nF				
470 nF		0.85 ±0.1		
680 nF				
1 µF		0.85 ±0.1		

NOTE

I. Values in shaded cells indicate thickness class in mm

CAPACITANCE RANGE & THICKNESS FOR X7R

Table 4 Sizes from 0612

CAP.	0612				
	6.3 V	10 V	16 V	25 V	50 V
10 nF	0.85 ±0.1	0.85 ±0.1	0.85 ±0.1	0.85 ±0.1	0.85 ±0.1
15 nF	0.85 ±0.1	0.85 ±0.1	0.85 ±0.1	0.85 ±0.1	0.85 ±0.1
22 nF	0.85 ±0.1	0.85 ±0.1	0.85 ±0.1	0.85 ±0.1	0.85 ±0.1
33 nF	0.85 ±0.1	0.85 ±0.1	0.85 ±0.1	0.85 ±0.1	0.85 ±0.1
47 nF	0.85 ±0.1	0.85 ±0.1	0.85 ±0.1	0.85 ±0.1	0.85 ±0.1
68 nF	0.85 ±0.1	0.85 ±0.1	0.85 ±0.1	0.85 ±0.1	0.85 ±0.1
100 nF	0.85 ±0.1	0.85 ±0.1	0.85 ±0.1	0.85 ±0.1	0.85 ±0.1
150 nF	0.85 ±0.1	0.85 ±0.1	0.85 ±0.1	1.15 ±0.1	1.15 ±0.1
220 nF	0.85 ±0.1	0.85 ±0.1	0.85 ±0.1	1.15 ±0.1	1.15 ±0.1
330 nF	0.85 ±0.1	0.85 ±0.1	0.85 ±0.1	1.15 ±0.1	1.15 ±0.1
470 nF	0.85 ±0.1	0.85 ±0.1	0.85 ±0.1	1.15 ±0.1	1.15 ±0.1
680 nF	1.15 ±0.1	1.15 ±0.1	1.15 ±0.1	1.15 ±0.1	1.15 ±0.1
1 µF	1.15 ±0.1	1.15 ±0.1	1.15 ±0.1	1.15 ±0.1	1.15 ±0.1

NOTE

1. Values in shaded cells indicate thickness class in mm

THICKNESS CLASSES AND PACKING QUANTITY

Table 5

SIZE CODE	THICKNESS CLASSIFICATION	TAPE WIDTH QUANTITY PER REEL	Ø180 MM / 7 INCH		Ø330 MM / 13 INCH		QUANTITY PER BULK CASE
			Paper	Blister	Paper	Blister	
0204	0.3 ±0.05 mm	8 mm	10,000	---	---	---	---
0306	0.5 ±0.1 mm	8 mm	4,000	---	15,000	---	---
0508	0.85 ±0.1 mm	8 mm	4,000	---	15,000	---	---
0612	0.85 ±0.1 mm	8 mm	4,000	---	15,000	---	---
0612	1.15 ±0.1 mm	8 mm	---	3,000	---	---	---

ELECTRICAL CHARACTERISTICS**X7R DIELECTRIC CAPACITORS**

Unless otherwise specified, all test and measurements shall be made under standard atmospheric conditions for testing as given in 5.3 of IEC 60068-1:

- Temperature: 15 ° C to 35 ° C
- Relative humidity: 25% to 75%
- Air pressure: 86 kPa to 106 kPa

Before the measurements are made, the capacitor shall be stored at the measuring temperature for a time sufficient to allow the entire capacitor to reach this temperature.

The period as prescribed for recovery at the end of a test is normally sufficient for this purpose.

Table 6

DESCRIPTION	VALUE
Capacitance range	10 nF to 1 uF
Capacitance tolerance	
X5R / X7R	±10%, ±20%
Dissipation factor (D.F.)	
X5R / X7R	≤ 5 %
Insulation resistance after 1 minute at U_r (DC)	$R_{ins} \geq 10 \text{ G}\Omega$ or $R_{ins} \times C \geq 500 \text{ }\Omega \cdot \text{F}$ whichever is less
Maximum capacitance change as a function of temperature (temperature characteristic/coefficient):	
X5R / X7R	±15%
Operating temperature range:	
X5R	-55 °C to +85 °C
X7R	-55 °C to +125 °C

SOLDERING RECOMMENDATION

Table 7

SOLDERING METHOD	SIZE			
	0204	0306	0508	0612
Reflow				
Reflow/Wave	○	○	○	○

TESTS AND REQUIREMENTS

Table 8 Test procedures and requirements

TEST	TEST METHOD	PROCEDURE	REQUIREMENTS
Mounting	IEC 4.3 60384-21/22	The capacitors may be mounted on printed-circuit boards or ceramic substrates	No visible damage
Visual Inspection and Dimension Check	4.4	Any applicable method using × 10 magnification	In accordance with specification
Capacitance	4.5.1	f = 1 KHz, measuring at voltage 1 Vrms at 20 °C	Within specified tolerance
Dissipation Factor (D.F.)	4.5.2	f = 1 KHz, measuring at voltage 1 Vrms at 20 °C	In accordance with specification
Insulation Resistance	4.5.3	At Ur (DC) for 1 minute	In accordance with specification

TEST	TEST METHOD	PROCEDURE	REQUIREMENTS									
Temperature coefficient	4.6	Capacitance shall be measured by the steps shown in the following table. The capacitance change should be measured after 5 min at each specified temperature stage.	X7R/X5R : $\Delta C/C$: $\pm 15\%$ In case of applying voltage, the capacitance change should be measured after 1 more min. with applying voltage in equilibration of each temp. stage.									
		<table border="1"> <thead> <tr> <th>Step</th> <th>Temperature(°C)</th> </tr> </thead> <tbody> <tr> <td>a</td> <td>25±2</td> </tr> <tr> <td>b</td> <td>Lower temperature±3°C</td> </tr> <tr> <td>c</td> <td>25±2</td> </tr> <tr> <td>d</td> <td>Upper Temperature±2°C</td> </tr> <tr> <td>e</td> <td>25±2</td> </tr> </tbody> </table> <p>Capacitance Change shall be calculated from the formula as below $\Delta C = \frac{C2 - C1}{C1} \times 100\%$ C1: Capacitance at step c C2: Capacitance at step b or d</p>		Step	Temperature(°C)	a	25±2	b	Lower temperature±3°C	c	25±2	d
Step	Temperature(°C)											
a	25±2											
b	Lower temperature±3°C											
c	25±2											
d	Upper Temperature±2°C											
e	25±2											
Adhesion	IEC 60384-21/22	4.7 A force applied for 10 seconds to the line joining the terminations and in a plane parallel to the substrate	Force size \geq 0306: 5N size = 0204: 2.5N									
Bending Strength		4.8 Mounting in accordance with IEC 60384-22 paragraph 4.3 Conditions: bending 1 mm at a rate of 1 mm/s, radius jig 5 mm	No visible damage $\Delta C/Cs$ X7R/X5R : $\pm 10\%$									

TEST	TEST METHOD	PROCEDURE	REQUIREMENTS
Resistance to Soldering Heat	4.9	Precondition: 150 +0/-10 °C for 1 hour, then keep for 24 ±1 hours at room temperature	Dissolution of the end face plating shall not exceed 25% of the length of the edge concerned
		Preheating: 120 °C to 150 °C for 1 minute and 170 °C to 200 °C for 1 minute. Solder bath temperature: 260 ±5 °C Dipping time: 10 ±0.5 seconds Recovery time: 24 ±2 hours	$\Delta C/C$ X7R/X5R : ±10% D.F. within initial specified value R_{ins} within initial specified value
Solderability	4.10	Preheated the temperature of 80 °C to 140 °C and maintained for 30 seconds to 60 seconds.	The solder should cover over 95% of the critical area of each termination
		Test conditions for leadfree containing solder alloy Temperature: 245 ±5 °C Dipping time: 3 ±0.3 seconds Depth of immersion: 10 mm	
Rapid Change of Temperature	IEC 60384-21/22	4.11 Preconditioning; 150 +0/-10 °C for 1 hour, then keep for 24 ±1 hours at room temperature	No visual damage
		5 cycles with following detail: 30 minutes at lower category temperature 30 minutes at upper category temperature Recovery time 24 ±2 hours	$\Delta C/C$ X7R/X5R : ±15% D.F. meet initial specified value R_{ins} meet initial specified value

TEST	TEST METHOD	PROCEDURE	REQUIREMENTS
Damp Heat with Ur load	4.13	<ol style="list-style-type: none"> 1. Preconditioning, class 2 only: 150 +0/-10 °C /1 hour, then keep for 24 ±1 hour at room temp 2. Initial measure: Spec: refer initial spec C, D, IR 3. Damp heat test: 500 ±12 hours at 40 ±2 °C; 90 to 95% R.H; 1.0 Ur applied. 4. Recovery: 24 ±2 hours 5. Final measure: C, D, IR <p>P.S. If the capacitance value is less than the minimum value permitted, then after the other measurements have been made the capacitor shall be precondition according to "IEC 60384 4.1" and then the requirement shall be met.</p>	<p>No visual damage after recovery</p> <hr/> <p>$\Delta C/C$ $< 1\mu F : \pm 15\%$ $\geq 1\mu F : \pm 20\%$</p> <p>D.F. $\leq 2 \times$ specified value</p> <p>R_{ins} $\geq 500 M\Omega$ or $R_{ins} \times C_r \geq 25\Omega \cdot F$ whichever is less</p>
Endurance	IEC 60384-21/22	4.14 <ol style="list-style-type: none"> 1. Preconditioning, 150 +0/-10 °C /1 hour, then keep for 24 ±1 hour at room temp 2. Initial measure: Spec: refer initial spec C, D, IR 3. Endurance test: Temperature: Specified stress voltage applied for 1,000 hours: Applied $2.0 \times U_r$ for general product Recovery time: 24 ±2 hours 4. Final measure: C, D, IR <p>P.S. If the capacitance value is less than the minimum value permitted, then after the other measurements have been made the capacitor shall be precondition according to "IEC 60384 4.1" and then the requirement shall be met.</p>	<p>No visual damage</p> <hr/> <p>$\Delta C/C$ $< 1\mu F : \pm 15\%$ $\geq 1\mu F : \pm 20\%$</p> <p>D.F. $\leq 2x$ initial value max</p> <p>R_{ins} $\geq 1,000 M\Omega$ or $R_{ins} \times C_r \geq 50\Omega \cdot F$ whichever is less</p>
Voltage Proof	IEC 60384-1	4.5.4 <p>Specified stress voltage applied for 1 to 5 seconds $U_r \leq 100 V$: series applied $2.5 U_r$ Charge/Discharge current less than 50mA</p>	No breakdown or flashover

PAPER/PE TAPE SPECIFICATION

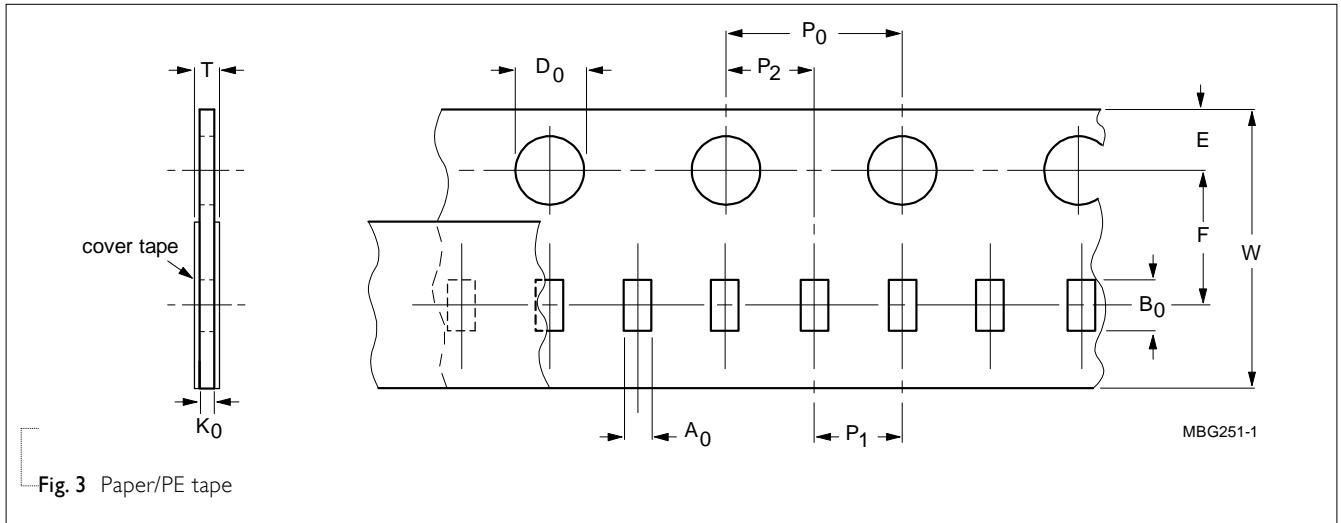

Fig. 3 Paper/PE tape

Table 9 Dimensions of paper/PE tape for relevant chip size; see Fig.3

SIZE	SYMBOL											Unit: mm
CODE	A_0	B_0	W	E	F	P_0 ⁽¹⁾	P_1	P_2	$\varnothing D_0$	K_0	T	
0204	0.70 ± 0.15	1.21 ± 0.12	8.0 ± 0.20	1.75 ± 0.1	3.50 ± 0.05	4.0 ± 0.05	2.0 ± 0.05	2.0 ± 0.05	$1.50 +0.1 /-0$	$(0.75 / 0.60) \pm 0.10$	$(0.85 / 0.70) \pm 0.10$	
0306	1.05 ± 0.14	1.86 ± 0.13	8.0 ± 0.20	1.75 ± 0.1	3.50 ± 0.05	4.0 ± 0.10	4.0 ± 0.10	2.0 ± 0.05	$1.50 +0.1 /-0$	$(1.05 / 0.95 / 0.75) \pm 0.10$	$(1.15 / 1.05 / 0.85) \pm 0.10$	
0508	1.50 ± 0.15	2.26 ± 0.20	8.0 ± 0.20	1.75 ± 0.1	3.50 ± 0.05	4.0 ± 0.10	4.0 ± 0.10	2.0 ± 0.05	$1.50 +0.1 /-0$	$(1.05 / 0.95 / 0.75) \pm 0.10$	$(1.15 / 1.05 / 0.85) \pm 0.10$	
0612	1.90 ± 0.15	3.50 ± 0.20	8.0 ± 0.20	1.75 ± 0.1	3.50 ± 0.05	4.0 ± 0.10	4.0 ± 0.10	2.0 ± 0.05	$1.50 +0.1 /-0$	$(0.95 / 0.75) \pm 0.10$	$(1.05 / 0.85) \pm 0.10$	

NOTE

1. P_0 pitch tolerance over any 10 pitches is ± 0.2 mm

REEL SPECIFICATION

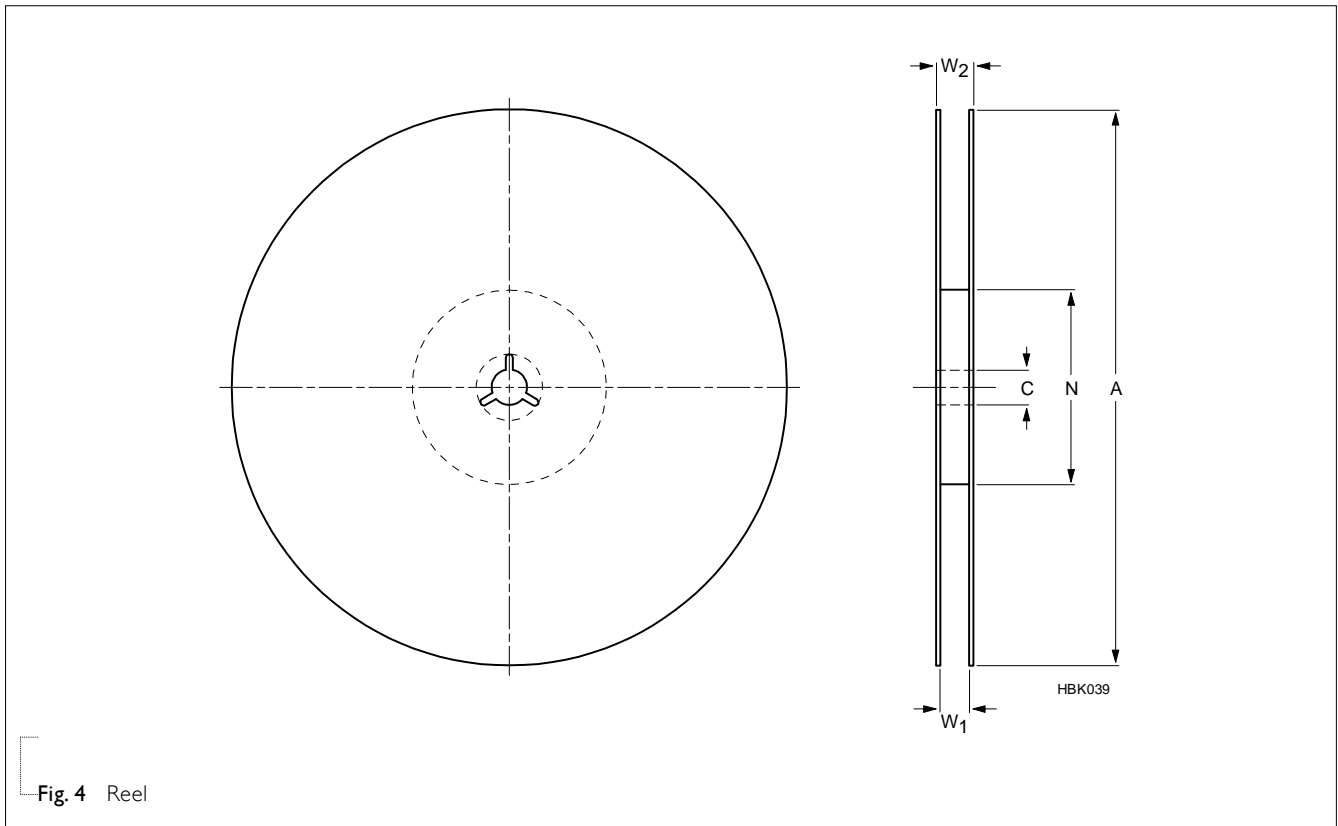

Fig. 4 Reel

Table 10 Reel dimensions; see Fig.5

TAPE WIDTH	SYMBOL			Unit: mm	
	A	N	C	W_1	W_{2max}
8 (Ø178 mm/7")	178 ±1.0	60 ±1.0	13 +0.50/-0.20	9.4 ±1.5	14.4
8 (Ø330 mm/13")	330 ±1.0	100 ±1.0	13 +0.50/-0.20	9.0 ±0.2	14.4
12 (Ø178 mm/7")	178 ±1.0	60 ±1.0	13 +0.50/-0.20	13.4 ±1.5	18.4

PROPERTIES OF REEL

Material: polystyrene

Surface resistance: $<10^{10}$ X/sq.

MOUNTING

SOLDER REPAIRS

Conventional solder repairs are carried out with a soldering iron as shown as Tab. II. The tip of the soldering iron should not directly touch the chip component to avoid thermal shock on the interface between termination and body during mounting, repairing or de-mounting processes. Ensure the termination solder has melted before removing the chip component.

Table II Recommended soldering iron condition

TYPE	Temp(°C)	DURATION (SEC.)	PREHEATING TEMP(°C)	ATMOSPHERE
CL0204/CL0306/CL0508/CL0612	350 max.	3 max.	150 min.	air

SOLDERING CONDITIONS

For normal use the capacitors may be mounted on printed-circuit boards or ceramic substrates by applying wave soldering, reflow soldering or conductive adhesive in accordance with IEC 61760-1 (Standard method for the specification of surface mounting components). For advised soldering profiles see Figs 5, 6, 7.

An improper combination of soldering, substrate and chip size can lead to a damaging of the component. The risk increases with the chip size and with temperature fluctuations (>100 °C).

Therefore, it is advised to use the smallest possible size and follow the dimensional recommendations given in Tables 12 for reflow and wave soldering. More detailed information is available on request.

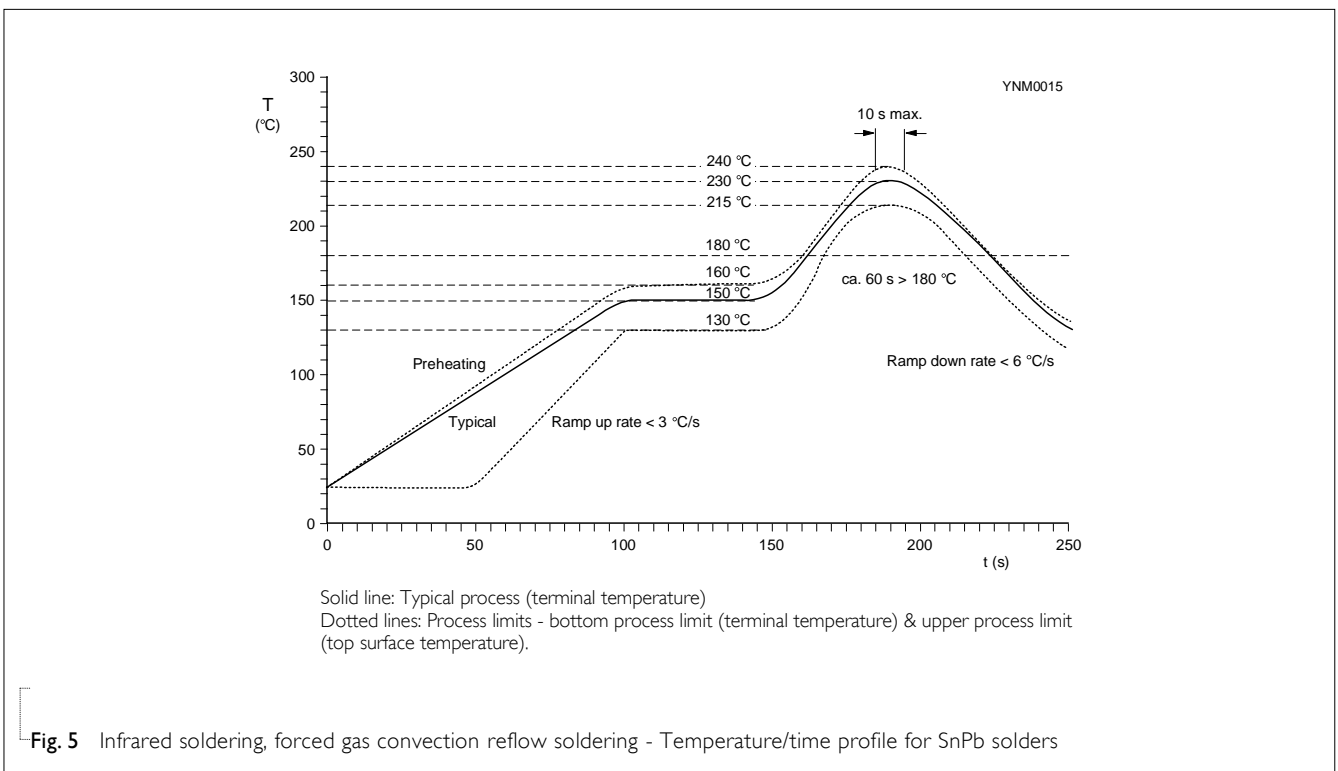

Fig. 5 Infrared soldering, forced gas convection reflow soldering - Temperature/time profile for SnPb solders

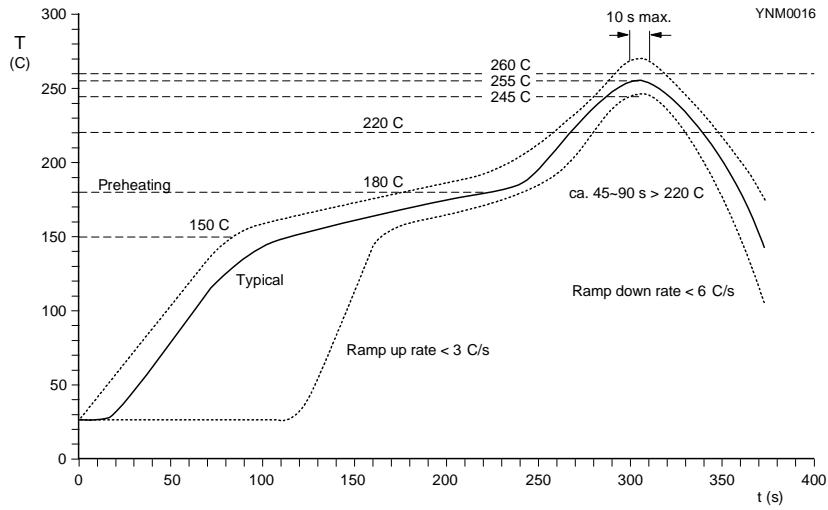

Fig. 6 Infrared soldering, forced gas convection reflow soldering - Temperature/time profile for lead-free SnAgCu solders

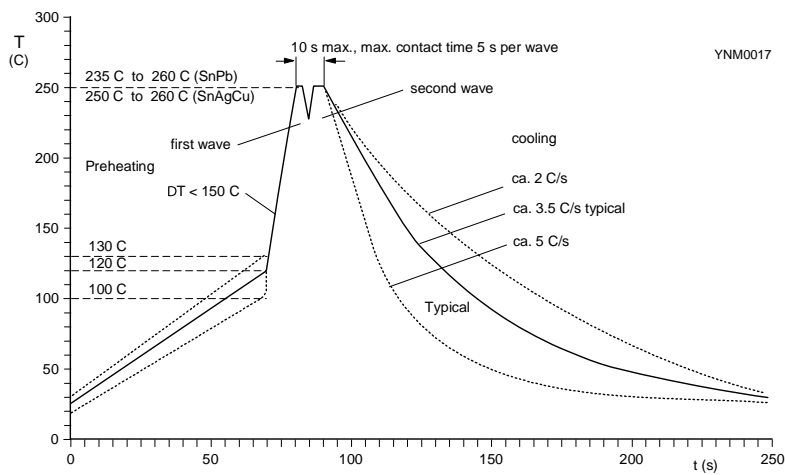

Fig. 7 Double wave soldering for SnPb and lead-free SnAgCu solder - Temperature/time profile (terminal temperature)

FOOTPRINT DIMENSIONS

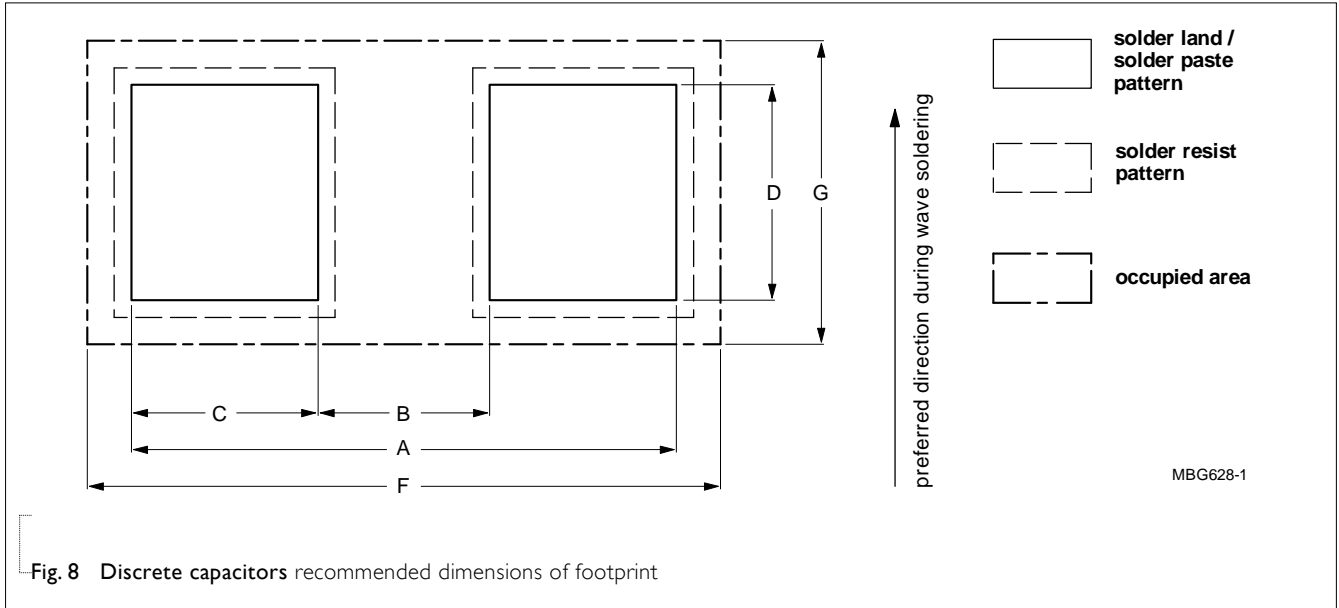

Fig. 8 Discrete capacitors recommended dimensions of footprint

Table 12 Reflow soldering; for footprint dimensions see Fig.8

SIZE CODE	FOOTPRINT DIMENSIONS						Unit: mm
	A	B	C	D	F	G	Processing remarks
0204	0.55~0.65	0.15~0.20	0.2~0.25	0.7~1.0	0.95 ±0.15	1.75 ±0.15	
0306	0.7~1.0	0.2~0.3	0.3~0.4	1.4~1.6	1.5 ±0.15	2.7±0.15	Ceramic substrate only
0508	1.2~1.5	0.4~0.5	0.4~0.5	1.4~1.8	2.1 ±0.25	3.2 ±0.25	
0612	1.8~2.3	0.6~0.8	0.6~0.7	2.6~2.8	2.5 ±0.25	4.4 ±0.25	

REVISION HISTORY

<u>REVISION</u>	<u>DATE</u>	<u>CHANGE NOTIFICATION</u>	<u>DESCRIPTION</u>
Version 2	May. 9, 2022	-	- Add 0306/X7R /6.3V and 10V/10nF to 68nF
Version 1	Nov. 7, 2016	-	- Add 13" packing
Version 0	Jun. 26, 2015	-	- New

LEGAL DISCLAIMER

YAGEO, its distributors and agents (collectively, "YAGEO"), hereby disclaims any and all liabilities for any errors, inaccuracies or incompleteness contained in any product related information, including but not limited to product specifications, datasheets, pictures and/or graphics. YAGEO may make changes, modifications and/or improvements to product related information at any time and without notice.



YAGEO makes no representation, warranty, and/or guarantee about the fitness of its products for any particular purpose or the continuing production of any of its products. To the maximum extent permitted by law, YAGEO disclaims (i) any and all liability arising out of the application or use of any YAGEO product, (ii) any and all liability, including without limitation special, consequential or incidental damages, and (iii) any and all implied warranties, including warranties of fitness for a particular purpose, non-infringement and merchantability.

YAGEO products are designed for general purpose applications under normal operation and usage conditions. Please contact YAGEO for the applications listed below which require especially high reliability for the prevention of defects which might directly cause damage to the third party's life, body or property: Aerospace equipment (artificial satellite, rocket, etc.), Atomic energy-related equipment, Aviation equipment, Disaster prevention equipment, crime prevention equipment, Electric heating apparatus, burning equipment, Highly public information network equipment, data-processing equipment, Medical devices, Military equipment, Power generation control equipment, Safety equipment, Traffic signal equipment, Transportation equipment and Undersea equipment, or for any other application or use in which the failure of YAGEO products could result in personal injury or death, or serious property damage. Particularly **YAGEO Corporation and its affiliates do not recommend the use of commercial or automotive grade products for high reliability applications or manned space flight.**

Information provided here is intended to indicate product specifications only. YAGEO reserves all the rights for revising this content without further notification, as long as products are unchanged. Any product change will be announced by PCN.

Looking for pricing, stock, or lifecycle information?

Click below to explore more details on WIN SOURCE:

-  [View CL0306KPX7R6BB224 on WIN SOURCE](#)
-  [Yageo Information](#)

Optimize Your Supply Chain with WIN SOURCE Solutions

-  Global Sourcing Solution
-  Obsolete Management
-  Cost Control Management
-  Shortage Management
-  Alternative Solution
-  Excess Inventory Management